



Operation Manual

PRODUCT NAME

***Compact Vacuum Unit Ejector/
Vacuum Pump System***

MODEL / Series / Product Number

ZB Series

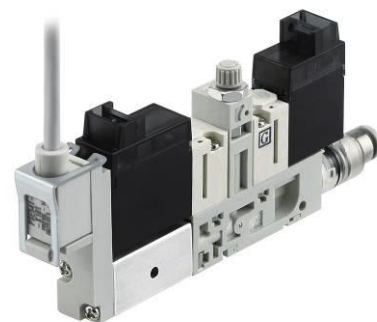
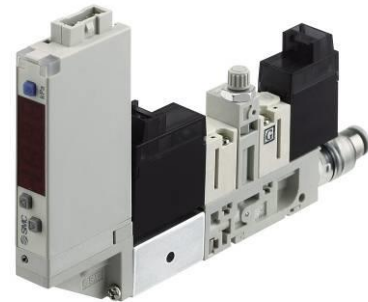
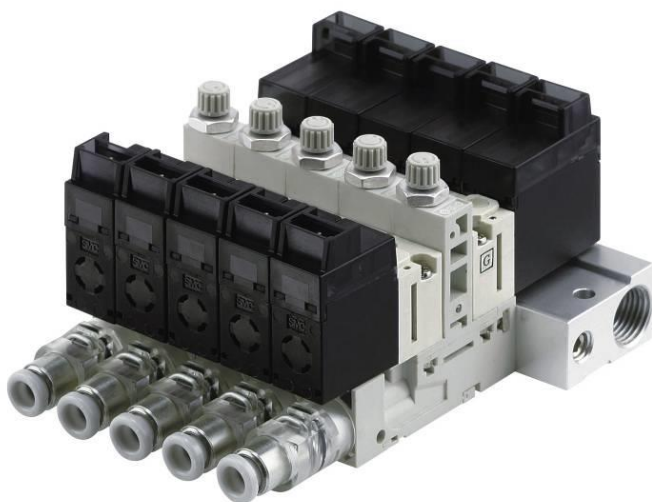

SMC Corporation

Contents

Safety Instructions	2
Model Indication and How to Order	10
Names of parts of product	16
Mounting and Installation	18
Air Supply	20
Supply Pressure	21
Piping	21
Handling of the V Port Assembly	22
Solenoid Valve	26
Construction	30
Maintenance	31
Replacement Procedure for Filter Element	36
Replacement Procedure for Silencer	37
Replacement Procedure for Solenoid Valve (Supply Valve, Release Valve)	38
Manifold Products	39
Filter Case	40
Vacuum release flow adjustment needle	40
Exhaust from Ejector	40
Specifications	41
Circuit Diagram	46
Weight	48
Exhaust Characteristics and Flow Characteristics of Ejector	49
Flow Characteristics of Vacuum Pump System	52
Flow Characteristics Curve	53
Pressure Sensor Assembly	53
Vacuum Pressure Switch Assembly	54
Troubleshooting	55



Safety Instructions

These safety instructions are intended to prevent hazardous situations and/or equipment damage. These instructions indicate the level of potential hazard with the labels of “**Caution**,” “**Warning**” or “**Danger**.” They are all important notes for safety and must be followed in addition to International Standards (ISO/IEC)^{*1)}, and other safety regulations.



*1) ISO 4414: Pneumatic fluid power - General rules and safety requirements for systems and their components

ISO 4413: Hydraulic fluid power - General rules and safety requirements for systems and their components

IEC 60204-1: Safety of machinery - Electrical equipment of machines - Part 1: General requirements

ISO 10218-1: Robots and robotic devices - Safety requirements for industrial robots - Part 1: Robots

etc.

	Danger	Danger indicates a hazard with a high level of risk which, if not avoided, will result in death or serious injury.
	Warning	Warning indicates a hazard with a medium level of risk which, if not avoided, could result in death or serious injury.
	Caution	Caution indicates a hazard with a low level of risk which, if not avoided, could result in minor or moderate injury.

Warning

1. The compatibility of the product is the responsibility of the person who designs the equipment or decides its specifications.

Since the product specified here is used under various operating conditions, its compatibility with specific equipment must be decided by the person who designs the equipment or decides its specifications based on necessary analysis and test results. The expected performance and safety assurance of the equipment will be the responsibility of the person who has determined its compatibility with the product. This person should also continuously review all specifications of the product referring to its latest catalog information, with a view to giving due consideration to any possibility of equipment failure when configuring the equipment.

2. Only personnel with appropriate training should operate machinery and equipment.

The product specified here may become unsafe if handled incorrectly. The assembly, operation and maintenance of machines or equipment including our products must be performed by an operator who is appropriately trained and experienced.

3. Do not service or attempt to remove product and machinery/equipment until safety is confirmed.

1. The inspection and maintenance of machinery/equipment should only be performed after measures to prevent falling or runaway of the driven objects have been confirmed.
2. When the product is to be removed, confirm that the safety measures as mentioned above are implemented and the power from any appropriate source is cut, and read and understand the specific product precautions of all relevant products carefully.
3. Before machinery/equipment is restarted, take measures to prevent unexpected operation and malfunction.

4. Our products cannot be used beyond their specifications. Our products are not developed, designed, and manufactured to be used under the following conditions or environments. Use under such conditions or environments is not covered.

1. Conditions and environments outside of the given specifications, or use outdoors or in a place exposed to direct sunlight.
2. Use for nuclear power, railways, aviation, space equipment, ships, vehicles, military application, equipment affecting human life, body, and property, fuel equipment, entertainment equipment, emergency shut-off circuits, press clutches, brake circuits, safety equipment, etc., and use for applications that do not conform to standard specifications such as catalogs and operation manuals.
3. Use for interlock circuits, except for use with double interlock such as installing a mechanical protection function in case of failure. Please periodically inspect the product to confirm that the product is operating properly.



Safety Instructions

Caution

We develop, design, and manufacture our products to be used for automatic control equipment, and provide them for peaceful use in manufacturing industries. Use in non-manufacturing industries is not covered.

Products we manufacture and sell cannot be used for the purpose of transactions or certification specified in the Measurement Act.

The new Measurement Act prohibits use of any unit other than SI units in Japan.

Limited warranty and Disclaimer/Compliance Requirements

The product used is subject to the following “Limited warranty and Disclaimer” and “Compliance Requirements”. Read and accept them before using the product.

Limited warranty and Disclaimer

1. The warranty period of the product is 1 year in service or 1.5 years after the product is delivered, whichever is first.*2)
Also, the product may have specified durability, running distance or replacement parts. Please consult your nearest sales branch.
2. For any failure or damage reported within the warranty period which is clearly our responsibility, a replacement product or necessary parts will be provided.
This limited warranty applies only to our product independently, and not to any other damage incurred due to the failure of the product.
3. Prior to using SMC products, please read and understand the warranty terms and disclaimers noted in the specified catalog for the particular products.

***2) Vacuum pads are excluded from this 1 year warranty.**



A vacuum pad is a consumable part, so it is warranted for a year after it is delivered.

Also, even within the warranty period, the wear of a product due to the use of the vacuum pad or failure due to the deterioration of rubber material are not covered by the limited warranty

Compliance Requirements

1. The use of SMC products with production equipment for the manufacture of weapons of mass destruction (WMD) or any other weapon is strictly prohibited.
2. The exports of SMC products or technology from one country to another are governed by the relevant security laws and regulations of the countries involved in the transaction. Prior to the shipment of a SMC product to another country, assure that all local rules governing that export are known and followed.









■ Explanation of Symbols





Symbol	Definition
	Things you must not do. Instructions are provided as a drawing or sentence next to the symbol.
	Things you must do Instructions are provided as a drawing or sentence next to the symbol.

■ Operator

1. This Operation Manual is intended for those who have knowledge of machinery using pneumatic equipment, and have sufficient knowledge of assembly, operation and maintenance of such equipment.
Only those persons are allowed to perform assembly, operation and maintenance.
2. Read and understand this Operation Manual carefully before assembling, operating or providing maintenance to the product.

■ Safety Instructions

 Warning	
 Disassembly prohibited	Do not disassemble, modify (including the replacement of board) or repair other than instructed in this manual. Otherwise, an injury or failure can result.
 Do not	Do not operate the product outside of the specifications. Do not use for flammable or harmful fluids. Fire, malfunction, or damage to the product can result. Please check the specifications before use.
 Do not	Do not use in an atmosphere containing flammable or explosive gases. Fire or an explosion can result. The product is not designed to be explosion proof.
 Do not	Do not use the product in a place where static electricity is a problem. Otherwise failure or malfunction of the system can result.
 Do not	Do not cut off the power and compressed air supplied to this product while it is operating. Otherwise it can cause injury due to dropping of workpieces or damage to the system.
 Instruction	If using the product in an interlocking circuit - Provide a double interlocking system, for example a mechanical system. - Check the product for proper operation. Otherwise malfunction can result, causing an accident.
 Instruction	The following instructions must be followed during maintenance - Turn off the power supply - Stop the air supply, exhaust the residual pressure in piping and verify that the air is released before performing maintenance work. It may cause an injury.

 Caution	
 Do not touch	Do not touch the terminals and connectors while the power is on. Otherwise electric shock, malfunction or damage to the switch can result.
 Instruction	Perform sufficient trial run. Otherwise, injury or damage to the system can result due to suction failure depending on the conditions of the suction of the workpiece or the pressure switch settings. Perform sufficient verification before using this product.
 Instruction	After maintenance is complete, perform appropriate functional inspections and leak test. Stop operation if the equipment does not function properly or there is leakage of fluid. If there is leakage from parts other than the piping, the product might be broken. Cut off the power supply and stop the fluid supply. Do not supply fluid if there is leakage. Safety cannot be assured in the case of an unexpected malfunction.

■ Handling Precautions

Follow the instructions given below for selecting and handling of the vacuum unit.

- The instructions on design and selection (installation, wiring, environment, adjustment, operation, maintenance, etc.) described below must be followed.

*Product specifications

- It is recommended to use compressed air which purity class is 2:6:3 of ISO8573-1:2010.
Insufficient air quality may cause operation failure.
If compressed air containing condensate is used, install an air dryer or drain catch before the filter and perform draining regularly.
If draining is not performed regularly and condensate enters the secondary side, it can cause operating failure of pneumatic equipment.
When it is difficult to control drainage, the use of a filter with an auto drain is recommended.
- The applicable fluids are air, non-corrosive gas and inert gas.
Do not use a fluid containing chemicals, synthetic oils including organic solvent, salt and corrosive gases.
Otherwise, damage to the vacuum unit and malfunction can result.
Check the details of the specifications before use.
- Use the specified operating pressure.
Otherwise it can cause damage to the vacuum unit or inability to adsorb correctly.
- Reserve a space for maintenance.
Design the system allowing the required space for maintenance.
- Use the specified voltage.
Otherwise failure or malfunction can result.
- Do not exceed the specified maximum allowable load.
Otherwise it can cause damage or shorten the life of the product.
- Design the product to prevent reverse current when the circuit is opened or the product is forced to operate for operational check.
Reverse current can cause malfunction or damage the product.

●Product handling

* Installation

- Tighten to the specified tightening torque.
If the tightening torque is exceeded, the mounting screws, brackets and the product can be broken. Insufficient torque can cause displacement of the product from its proper position and loosening of the mounting screws.
- If a commercially available switching power supply is used, be sure to ground the frame ground (FG) terminal.
- Do not drop, hit or apply excessive shock to the product.
Otherwise damage to the internal parts of the product, solenoid valve and internal parts of the pressure switch/sensor can result, causing malfunction.
- Do not pull the lead wire forcefully, or lift the product by pulling the lead wire. (Tensile strength 35N or less. Tensile strength for IO-Link pressure switch is 20N or less.)
Hold the product body when handling to prevent damage, failure or malfunction.
The solenoid valve and the pressure switch/sensor will be damaged, leading to failure and malfunction.
- Eliminate any dust left in the piping by using a blast of air before connecting the piping to the product.
It will cause failure or malfunction.
- Do not insert metal wires or other foreign objects into the pressure port of the pressure sensor.
The pressure sensor may get damaged, leading to failure and malfunction.
- If the fluid may contain foreign matter, install and connect a filter or mist separator to the inlet.
It will cause failure or malfunction.

* Wiring (Including connecting/disconnecting of the connectors)

- Do not pull hard on the lead wire, or lift the product by holding the lead wires (Tensile strength 49 N or less). In particular, never lift the product by the lead wire of the solenoid valve or the pressure switch/sensor when fittings and piping are built in.
Otherwise damage to the solenoid valve or the internal parts of the pressure switch/sensor can result, causing malfunction or causing the connector to come off.
- Avoid repeatedly bending, stretching or applying a heavy object or force to the lead wire.
Repetitive bending stress or tensile stress to the lead wire can cause the sheath of the wire to peel off.
If the lead wire can move, fix it near the body of the product.
The recommended bend radius of the lead wire is 6 times the outside diameter of the sheath, or 33 times the outside diameter of the insulation material, whichever is larger.
Replace the damaged lead wire with a new one.
- Wire correctly.
Incorrect wiring can cause malfunction or breakage of the solenoid valve or the pressure switch/sensor.
- Do not perform wiring while the power is on.
Otherwise damage to the solenoid valve or the internal parts of the pressure switch/sensor can result, causing malfunction.
- Do not route wires and cables together with power or high voltage cables.
Route the wires (piping) of the solenoid valve or the pressure switch/sensor separately from power or high voltage cables in order to avoid noise or surge entering the signal line from the power or high voltage line.
- Confirm proper insulation of wiring.
Poor insulation (interference with other circuits, poor insulation between terminals etc.) can apply excessive voltage or current to the solenoid valve or the pressure sensor/sensor, causing damage.
- Design the system to prevent reverse current when the product is forced to operate for operational check.
Depending on the circuit used, insulation may not be maintained when operation is forced, allowing reverse current to flow, which can cause malfunction and damage to the solenoid valve or the pressure switch/sensor.
- Keep wiring as short as possible to prevent interference from electromagnetic noise and surge voltage.
Do not use a cable longer than 10 m (Do not use the cable longer than 20 m for IO-Link pressure switch).
Wire the DC (-) line (solenoid valve: black, pressure switch/sensor: blue) as close as possible to the power supply.

***Operating environment**

- Do not use in an environment where corrosive gases, chemicals, sea water, water or steam are present. These may cause failure or malfunction.
- Do not use the product in a place where the product could be splashed by oil or chemicals. If the product is to be used in an environment containing oils or chemicals such as coolant or cleaning solvent, even for a short time, the solenoid valve or pressure switch/sensor may be adversely affected (damage, malfunction, or hardening of the lead wires).
- Do not use in an area where surges are generated. When there are machines or equipment that generate large surge near the pressure switch/sensor (magnetic type lifter, high frequency inductive furnace, motor, etc.), this can result in deterioration and damage of the internal elements. Take measures against the surge sources, and prevent the lines from coming into close contact.
- Do not use a load which generates surge voltage. When a surge-generating load such as a relay or solenoid is directly driven, use the product with a surge absorbing element built-in.
- The product is CE/UKCA marked, but not immune to lightning strikes, so take measures against lightning strikes. Be aware of excessive surrounding noise. The product is CE/UKCA marked and has passed the EMC test, but excessive noises in the surrounding area may affect the functioning of the product.
- Mount the product in a location that is not affected by vibration or impact. It will cause failure or malfunction.
- Do not let foreign matter, such as wire debris, get inside the product. In order to avoid failure and malfunction, do not let foreign matter, such as wire debris, get inside the product.
- Do not use the product in an environment that is exposed to temperature cycle. Heat cycles other than ordinary changes in temperature can adversely affect the inside of the product.
- Do not expose the product to direct sunlight. If using in a location directly exposed to sunlight, protect the product from the sunlight. Failure or malfunction may occur.
- Keep within the specified operating fluid and ambient temperature range. The operating fluid and ambient temperature range is 5 to 50°C. Operation under low temperature may lead to damage or operation failure due to frozen moisture in the fluid or air. Protection against freezing is necessary. Mounting of an air dryer is recommended for elimination of drainage and water. Avoid abrupt temperature changes even within the specified temperature range.
- Do not use in a location where the product is exposed to radiant heat from surrounding heat sources. Insufficient air quality may cause operation failure.

*** Adjustment and Operation**

- Connect a load before turning the power supply on. If the power supply is turned on with no load, over current may flow, causing the pressure switch/sensor to break instantly.
- Do not short-circuit the load. An error is displayed when the load of the pressure switch/sensor is short circuited, but over current may flow, causing damage to the pressure switch.
- Do not press the setting buttons with a sharp pointed object. This may damage the setting buttons.
- If using the product to detect very small pressures, warm up the product for 10 to 15 minutes first. There will be a drift on the display of approximately 1% for 10 minutes after the power supply is turned on.
- Perform settings suitable for the operating conditions. Incorrect setting can cause operation failure. For details of each setting, refer to the Operation Manual of the pressure switch/sensor.
- Do not touch the LED during operation. The display can vary due to static electricity.

***Maintenance**

- Turn off the power supply, stop the supplied air, exhaust the residual compressed air in the piping and verify the release of air before performing maintenance.
There is a risk of unexpected malfunction of component.
- Perform regular maintenance and inspections.
There is a risk of unexpected failure of components due to the malfunction of equipment and machinery.
- Perform draining regularly.
If condensate enters the secondary side, it can cause operating failure of pneumatic equipment.
- Do not use solvents such as benzene, thinner etc. to clean the product.
This may damage the surface of the body or erase the markings on the body.
Use a soft cloth to remove stains. For heavy stains, use a cloth soaked with diluted neutral detergent and fully squeezed, then wipe up the stains again with a dry cloth.

Model Indication and How to Order

Model Indication of the Single Unit

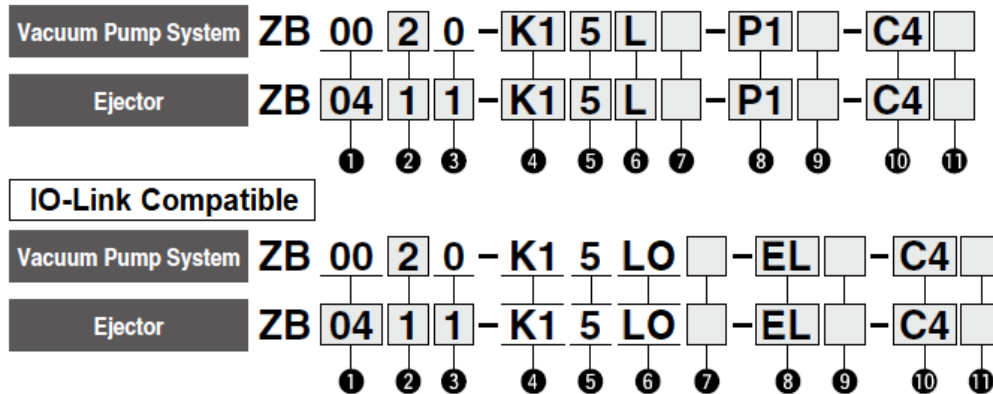

(1) Nozzle size

Symbol	Nominal nozzle size	Applicable supply valve and standard supply pressure	
		Large flow (N.C.)	Latching
00 <small>Note 1)</small>	—	●	—
03	φ 0.3	●(0.35MPa)	●(0.4MPa)
04	φ 0.4	●(0.35MPa)	●(0.4MPa)
05	φ 0.5	●(0.35MPa)	
06	φ 0.6	●(0.5MPa)	

Note1) Vacuum pump system only

(2) Body type

Symbol	Body spec.	Port specifications <small>Note 2)</small>
1	Single unit	Common for PV and PD (PV = PD)
2	Single unit	Separate for PV and PD (PV ≠ PD)
3	Manifold	No distinction

Note 2) Names of the ports and functions are as follows.

PV: Air pressure supply port (Ejector), Vacuum pressure supply port (Vacuum pump system)

PD: Burst pressure supply port (Select the model with a release valve for (4).)

(3) Exhaust type

0	Vacuum pump system (without silencer)
1	Exhaust through silencer (Individual exhaust)
2	Exhaust through port (M5, individual exhaust)

(4) Combinations of the supply valve and the release valve ^{Note 3)}

Symbol	Supply valve	Release valve	Applicable body type			
			Ejector		Pump system	
			PV=P D	PV≠PD	PV=PD	PV≠PD
K1	N.C.	N.C.	●	●	—	●
J1	N.C.	No	●*	—	●*	—
Q1	Latching (+ common)	N.C.	●	●	—	—
Q2	Latching (+ common)	No	●*	—	—	—

*Vacuum is released through the port to atmosphere for the model without the release valve.
Note 3) Latching type is applicable only to the ejector nozzle sizes 0.3 and 0.4.

(5) Rated voltage

5	24V DC
6	12V DC

(6) Electrical entry of the supply valve and release valve ^{Note 4)}

L	L plug connector with lead wire
LO	L plug connector without connector
M	M plug connector ^{Note 5)} with lead wire
MO	M plug connector ^{Note 5)} without connector

Note 4) All with light and surge suppressor. Lead wire length is 300mm.

Note 5) M and MO type connectors cannot be selected for the model with the pressure sensor or the pressure switch for vacuum.

(7) Manual override ^{Note 6)}

NIL	Non-locking push type
B	Locking type (Tool required) Semi-standard

Note 6) Latching type (supply valve) has the push-lock type only, but either the push type or the lock type can be selected for the release valve.

(8) Pressure sensor/ Vacuum pressure switch

Symbol	Type	Pressure range [kPa]	Specifications		
NIL	Without pressure sensor/ vacuum pressure switch				
P1	Pressure sensor	0 to -101	Output 1 to 5V, accuracy +/-2%F.S. or less ^{Note 8)}		
P3		-100 to 100	Output 1 to 5V, accuracy +/-2%F.S. or less ^{Note 8)}		
EA	Pressure switch for vacuum ^{Note 7)}	0 to -101	NPN2 output	Unit conversion function ^{Note 9)}	
EAM				Fixed to SI units ^{Note 10)}	
EAP			Unit conversion function [Initial value PSI] ^{Note 9)}		
EB			PNP2 output	Unit conversion function ^{Note 9)}	
EBM				Fixed to SI units ^{Note 10)}	
EBP			Unit conversion function [Initial value PSI] ^{Note 9)}		
FA		-100 to 100	NPN2 output	Unit conversion function ^{Note 9)}	
FAM				Fixed to SI units ^{Note 10)}	
FAP			Unit conversion function [Initial value PSI] ^{Note 9)}		
FB			PNP2 output	Unit conversion function ^{Note 9)}	
FBM				Fixed to SI units ^{Note 10)}	
FBP			Unit conversion function [Initial value PSI] ^{Note 9)}		
EL		0 to -101	IO-Link	Unit conversion function ^{Note 9)}	
ELM				Fixed to SI units ^{Note 10)}	
FL				-100 to 100	Unit conversion function ^{Note 9)}
FLM					Fixed to SI units ^{Note 10)}

Note 7) The energy saving function is not available.

Note 8) Only the lead wire length 3m is available for the pressure sensor.

Note 9) The unit conversion function is not for use in Japan due to a new measurement law.

Note 10) Fixed unit: kPa

(9) Lead wire with connector for vacuum pressure switch

NIL	Without lead wire with connector (No need to specify for the pressure sensor)
G	Lead wire with connector and connector cover, Lead wire length 2m
H	Lead wire with connector for IO-Link (With M12 connector, Lead wire length 0.3m)

(10) Vacuum (V) port ^{Note11)} ^{Note 12)}

C2	Straight type $\phi 2$ One-touch tube fitting	Metric size
C4	Straight type $\phi 4$ One-touch tube fitting	
N1	Straight type $\phi 1/8$ " One-touch tube fitting	Inch size
N3	Straight type $\phi 5/32$ " One-touch tube fitting	
L2	Elbow type $\phi 2$ One-touch tube fitting	Metric size
L4	Elbow type $\phi 4$ One-touch tube fitting	
LN1	Elbow type $\phi 1/8$ " One-touch tube fitting	Inch size
LN3	Elbow type $\phi 5/32$ " One-touch tube fitting	

Note 11) The standard filter in this product is a low cost filter. If the product is to be used in a dusty environment, use an air suction filter (ZFA or ZFB or ZFC series) together in order to avoid clogging of the filter in an earlier stage.

Note 12) Be sure to hold the filter case when connecting and disconnecting the tube for the elbow type.

(11) Options ^{Note 13)}

NIL	No options
B	With bracket for single unit (Enclosed with the product for shipment without being assembled)
K	Screw driver handling type vacuum release needle ^{Note14)}

Note 13) When multiple options are selected, state them in alphabetical order.

Note 14) Knob operated type is standard.

■ Model Indication for Manifold

ZZB **08** - **S** **01** **M5**

1
2
3
4

(1) Number of stations

01	1 station
02	2 stations
⋮	⋮
12	12 stations

(2) Pressure sensor/Vacuum pressure switch mountable ^{Note 1)}

NIL	Sensor/ switch non-mountable base
S	Sensor/ switch mountable base

Note 1) Select "S" when the model with either the pressure sensor or the pressure switch for vacuum is selected for how-to-order for the single unit (8).

(3) Common supply pressure (PV) connecting port size

01	Rc1/8
01N	NPT1/8
01F	G1/8
M5	M5×0.8

(4) Common vacuum burst pressure (PD) port ^{Note 2)}

NIL	Without PD port (PV = PD)
M5	M5×0.8 (PV≠PD)

Note 2) Refer to model indication for single unit (4) for the combinations of supply valve and release valve selectable.

■ Supply Port

Ports are provided on the left and right sides of the manifold base when looking from the V port side. When it is used with the air supply only from one side, a plug to close the unused port is necessary.

Purchase a plug suitable for the port size selected, and mount it to the unused port. (e.g. M-5P for M5X0.8)

■ Number of Manifold Stations Operable at the Same Time

For the manifold type, the maximum number of stations operable at the same time varies depending on the nozzle size of the ejector, the supply valve type, port size of the common supply port of the manifold base and the number of manifold bases connected. Refer to the table below for the appropriate number of stations operable at the same time and piping to give the full performance of the ejector.

Ejector model Supply valve type		ZB03		ZB04		ZB05	ZB06
		Large flow (N.C.)	Latching	Large flow (N.C.)	Latching	Large flow (N.C.)	Large flow (N.C.)
Supply (PV) port Port size							
Rc1/8 NPT1/8 G1/8	Supply from one side	12				10	12
	Supply from both sides					12	
M5x0.8	Supply from one side	10		8		10	
	Supply from both sides	12		10		12	

Note) The number of stations shown above is to satisfy the specifications of the ejector performance at the standard supply pressure.

Note) For a vacuum pump system, there is no limit for the number of stations operated at the same time, but the vacuum pressure and/or the suction flow can vary as the number of stations increases depending on the vacuum pump capacity.

Names of Parts of product

Names of Individual Part

Manifold

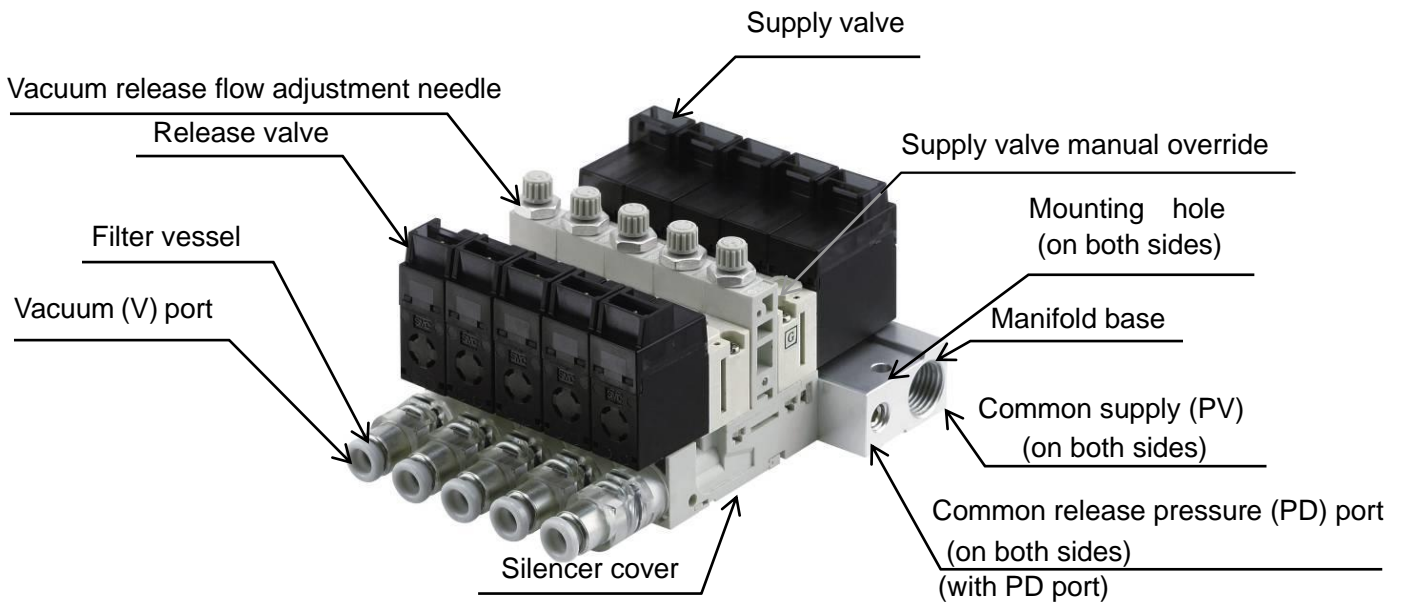

Single unit

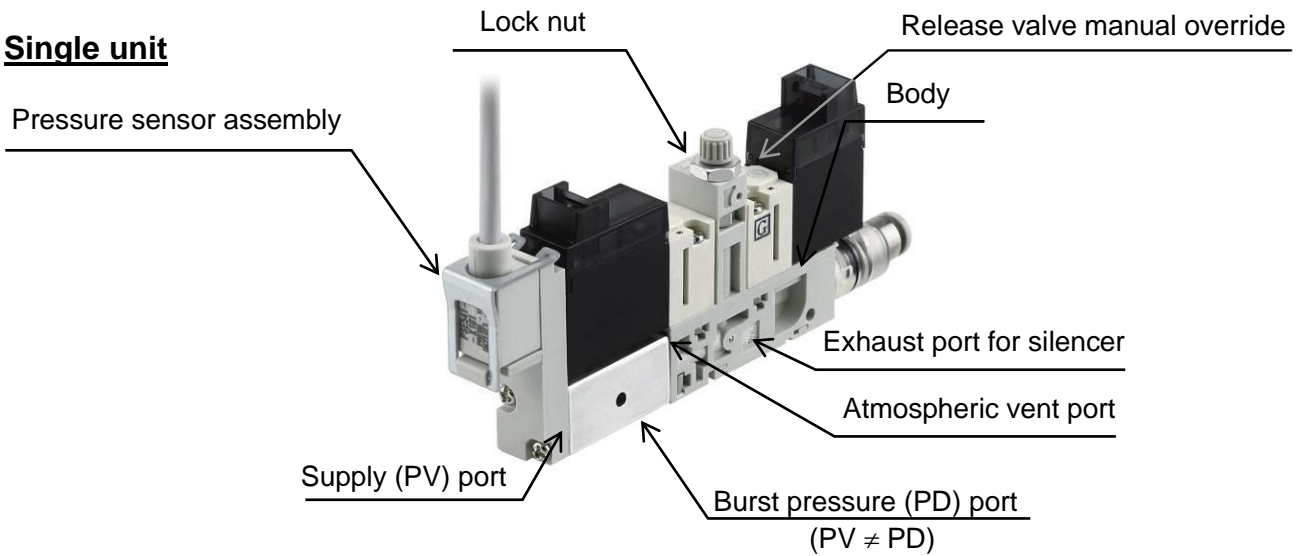

Summary of product elements

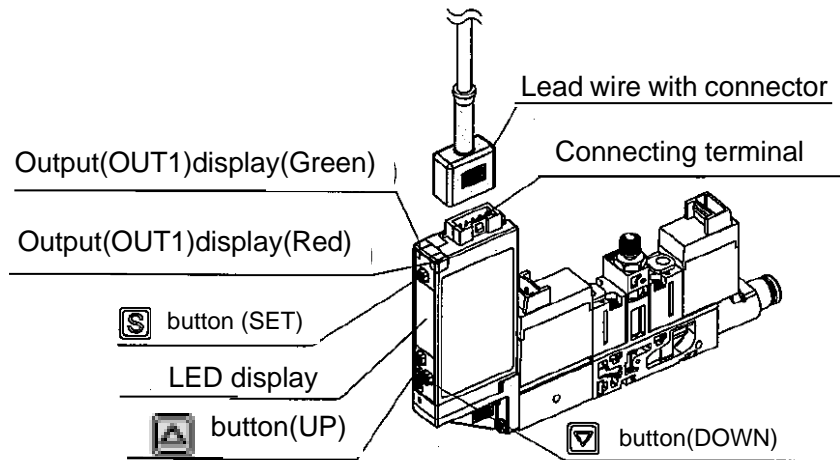

Output (OUT1)	Turns on when the switch output (OUT1) is on.
Output (OUT2)	Turns on when the switch output (OUT2) is on.
LED	Displays the current status of pressure, setting mode and error code.
△ button (UP)	Selects the mode and increases the ON/OFF set value. Press this button to change to the peak display mode.
▽ button (DOWN)	Selects the mode and decreases the ON/OFF set value. Press this button to change to the bottom display mode.
Ⓢ button (SET)	Press this button to change to either mode and to set a set value.

Mounting and Installation

Note the following points when mounting and installing the product.

Common Precautions for Mounting and Installation

- (1) It is necessary to perform maintenance and replacement of the suction filter regularly to maintain the proper operation of the ejector and vacuum pump system. Ensure sufficient space for maintenance work when installing the product.
- (2) The filter case of this product is integrated with the vacuum piping. Secure sufficient space and some length of the tube with the piping (tubes) on the vacuum side so that the case can be removed.
- (3) Do not fix the piping on the vacuum side such that a load is always applied to the filter case in a bending or pulling direction. This can damage the body and/or the filter case.
- (4) If the ejector (silencer exhaust specification) is operated in a dusty environment or if there is dust on the surface of the workpieces, it can cause clogging of the silencing material as well as the suction filter due to dust being sucked in. Secure space necessary for the maintenance check and replacement of the silencer when the ejector performance decreases.
- (5) Keep the ambient temperature of the product between -5 and 50°C . In environments such as inside a panel where heat radiation efficiency is poor, the ambient temperature will rise due to the heat generation of the coil of the solenoid valve, causing malfunction.
- (6) When handling the product, do not lift it by the lead wires or cables of the solenoid valve, pressure sensor or pressure switch for vacuum. Otherwise, it can cause vacuum leakage or broken wire or damage to the product.

Mounting and Installation of Single Unit Ejectors

- (1) The tightening torque for mounting the product to the wall should be between 0.075 and 0.096Nm . Using excessive torque may cause damage to the body. (The width of the product is 10mm .)
- (2) Do not block the exhaust port of the ejector. The ejector of the single unit specification has only one exhaust port on one side. If the ejector is mounted with the exhaust port facing a wall, secure a space of at least 1mm between the product and the wall using a spacer, shim or equivalent.

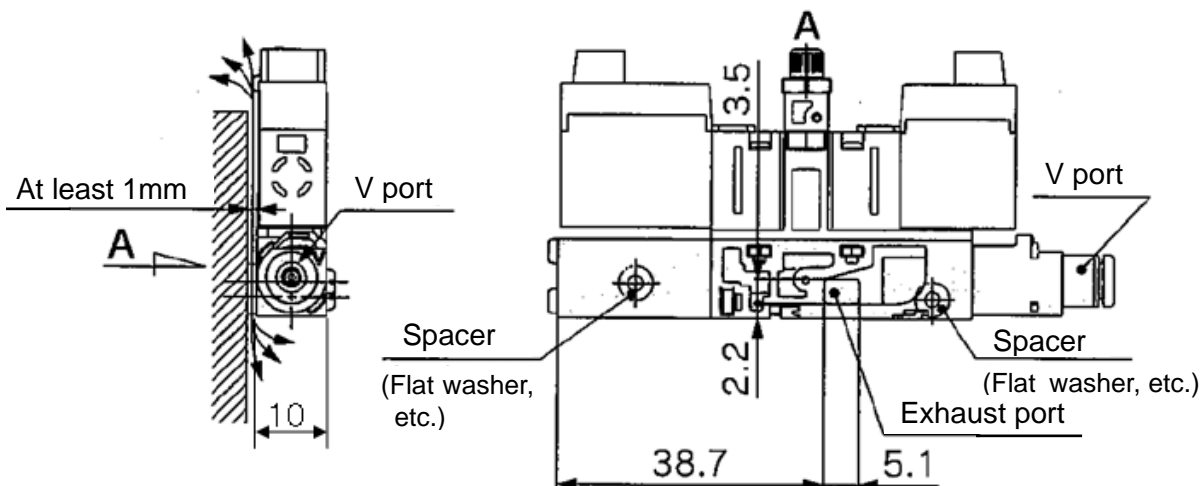

(3) Secure the space for connecting piping on the supply side when installing the product.

Mounting with a bracket for single unit (Width of the bracket: 1mm)

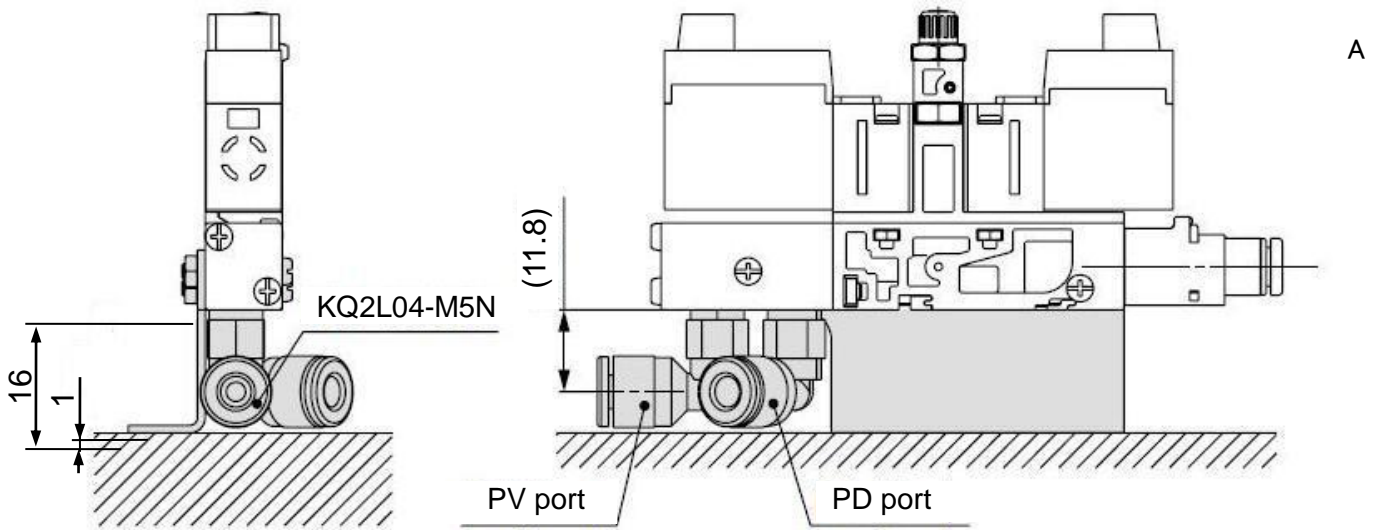

Mounting on the wall and the port released to the atmosphere at the bottom

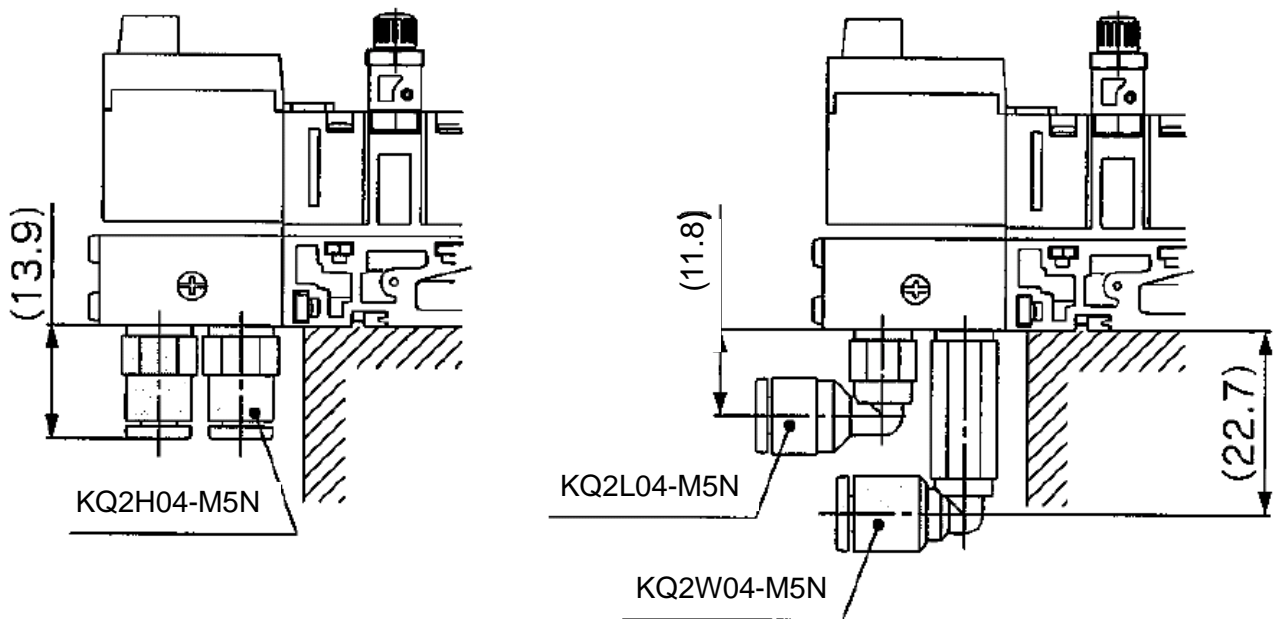

Part No. of the bracket for single unit: ZB1-BK1-A (Provided with 2 mounting screws M2x14 with washer and 2 hexagon nuts M2.)

Recommended tube fittings for the set-up shown above: KQ2H04-M5N, KQ2L04-M5N, KQ2W04-M5N.

■ Mounting and Installation of an Ejector of Manifold Specification

When mounting the manifold base, it is recommended to mount a spacer on the filter case side in order to make it easier to perform maintenance service of the filter element. (Width of the manifold base mounting hole: 11.6mm)

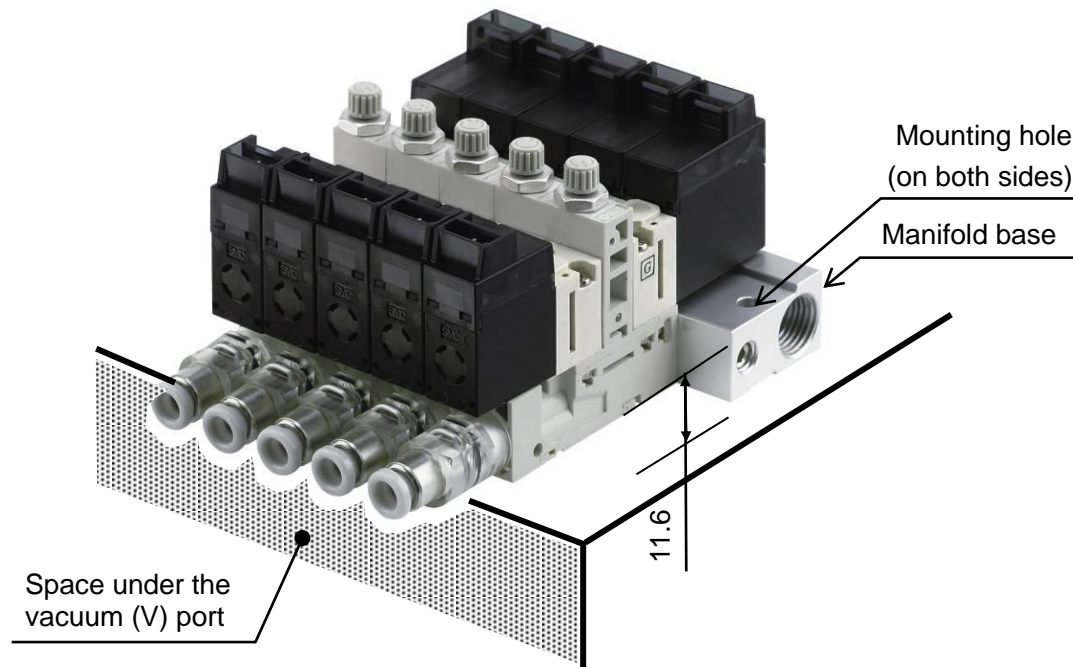

Air Supply

■ Use clean air.

- (1) Using compressed air which contains chemicals, synthetic oils containing organic solvents, salts or corrosive gases, etc. can cause damage or malfunction. Do not use compressed air containing toxic impurities.
- (2) If the compressed air contains excessive drainage or carbon powder, it can stick to the vacuum generating part (the nozzle diffuser) or inside of the solenoid valve or the pressure switch for vacuum and cause deterioration of the performance or operation failure.
- (3) It is recommended to use compressed air which purity class is 2:6:3 of ISO8573-1:2010.

It is recommended that an air filter and a mist separator are connected to the upstream side of the ejector and the pump system.

Supply Pressure

- Use the product within the specified supply pressure range.

Operation over the specified supply pressure range can cause damage to the product. Especially for the vacuum pump system with nozzle type pad, the pressure inside the product can increase due to the release pressure. Use the proper pressure and make sure that the adsorption part is not clogged.

Piping

- Piping for Air Pressure Supply and Vacuum Pressure Supply

(1) Preparation before piping

Before piping, perform air blow (flushing) or cleaning to remove any cutting chips, cutting oil, dust, etc. from the piping.

(2) Wrapping of pipe tape

When installing piping or a tube fitting into a port, prevent cutting chips and sealant material from getting inside the product.

If a sealant tape is used, leave 1 thread exposed at the end of threads.

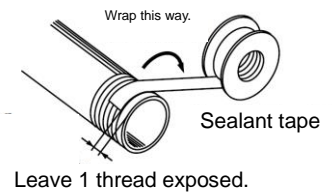

(3) When connecting tubing, consider factors such as changes in the tubing length due to pressure, and allow a sufficient margin.

Otherwise, it can damage the fitting and cause the tube to come off. Refer to Fittings & Tubing Precautions from 1 to 4 shown in Best Pneumatics 6 on SMC's website (URL <https://www.smcworld.com>) for the recommended piping conditions.

- Piping to the manifold base

(1) For the PV port of the manifold base, use a tube fitting whose maximum bore size of the outside dimension is smaller than 12mm.

Otherwise, the exterior of the fitting will interfere with the manifold base installation face.

Recommended tube fittings:

KQ2S06-01□S, KQ2S04-01□S

(2) Follow the tightening instructions shown below for each thread.

1/8 (PV port): First, tighten the fitting by hand, then use a wrench appropriate to tighten it a further two or three turns.

Tightening torque is 3 to 5N as a guide.

M5 (PV, PD port): After tightening by hand, increase the tightening by about 1/6 turn with a tightening tool.

Tightening torque is 1 to 1.5N as a guide.

(3) When mounting or removing the tube fitting, etc.

to the manifold base, hold the manifold base with a spanner.

If the ejector/vacuum pump system is held, it may cause air leakage or damage to the product.

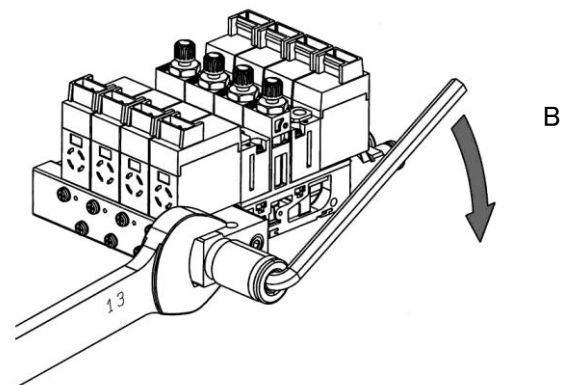

■ Piping to the Vacuum (V) Port

- (1) Allow a sufficient margin of tube length when piping, in order to prevent twisting, tensile, moment loads, vibration or impact being applied to the tubes and fittings.
This can cause damage to the tube fittings and crushing, bursting or disconnection of tubing.
- (2) Piping to the product is assumed to be static piping.
If the tube moves, it may become worn, elongated or torn due to tensile forces, or disconnected from the fitting. Ensure the tube is in a static condition at all times before using.
- (3) Prevent the connected tube from being rotated.
If the fittings are used in this way, the fitting may be broken.
- (4) Do not lift the product by holding the piping after the tube is connected to the vacuum (V) port.
Otherwise, the filter case and/or the One-touch tube fitting will be damaged.

Handling of the V Port Assembly

■ Precautions

- (1) The construction of the V port assembly is such that it can be attached or detached at a touch.

When mounting or removing, turn the filter case completely until it comes into the position where it cannot turn any further. Mount the filter case securely, otherwise the V port may come off or be damaged.

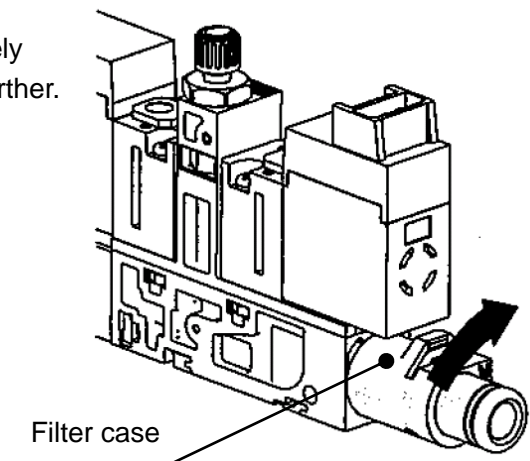

- (2) The V port assembly and removal may not be easy if the product is mounted on the floor.
If it is forcibly mounted or removed, the V port assembly may be damaged and/or it may cause vacuum leakage. If it is mounted on the floor, remove the manifold base once from the installation position and lift the body to perform mounting and removal work.
- (3) If the One-touch tube fitting is the straight type, a hexagon wrench (width across flats: 2mm) can be used.
The hexagon hole is resin, so it can be broken if excess torque is applied. Do not apply torque of 0.15Nm or more. Do not apply any more torque when it reaches the position where it cannot be turned further.

(4) When mounting the V port assembly again after it is removed, confirm that the filter case gasket is inserted properly into the groove on the body side.

If the filter case gasket is out of position, vacuum may leak or the V port assembly may come off.

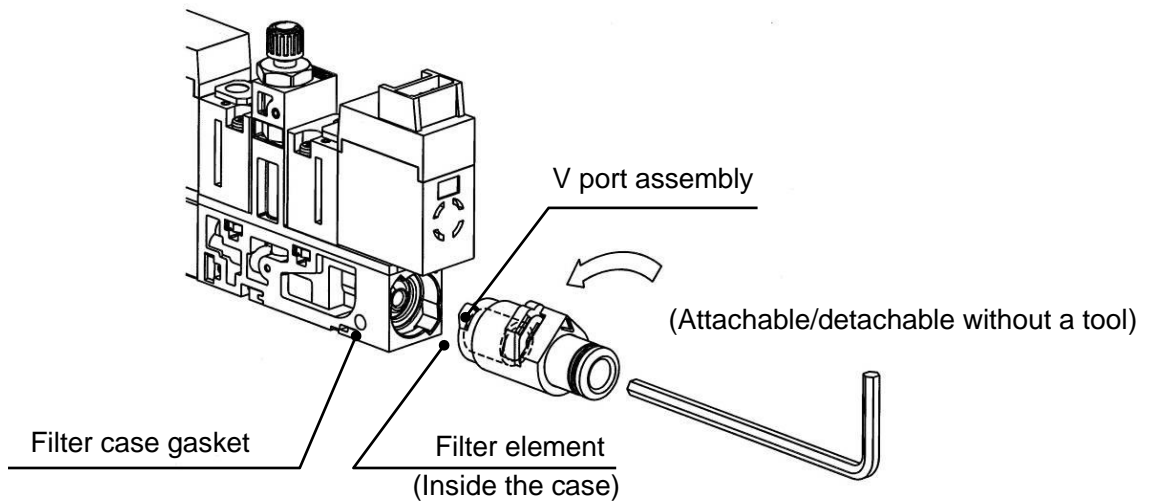

(5) When removing the elbow type V port assemblies, select one of the following two methods. (For replacement of the filter, One-touch tube fitting, etc.)

- 1) Remove the V port assemblies in order from the left hand side with the V port side facing the front.
- 2) Remove the clip of the V port assembly with a watchmaker's screw driver and pull out the One-touch tube fitting, and then, remove the case. (This procedure can be used when removing the case of the manifold in the intermediate position.)

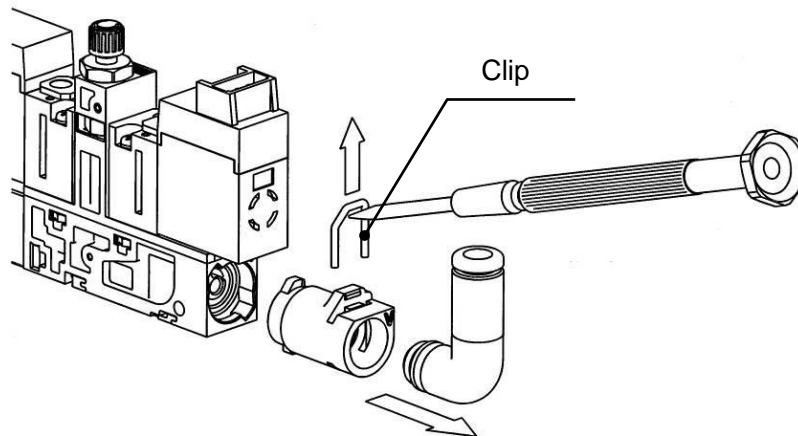

- (6) Make sure the O-rings of the One-touch fittings are free from scratches and dust.
Scratches or dust may result in air and vacuum leakage.
- (7) When pulling the straight type tube fitting assembly away from the V port assembly, remove the clip, then connect a tube or a plug to the One-touch fitting and pull it out holding the tube or plug.
Pulling the tube fitting assembly away by holding the release button (resin part) of the One-touch tube fitting can damage the release button.

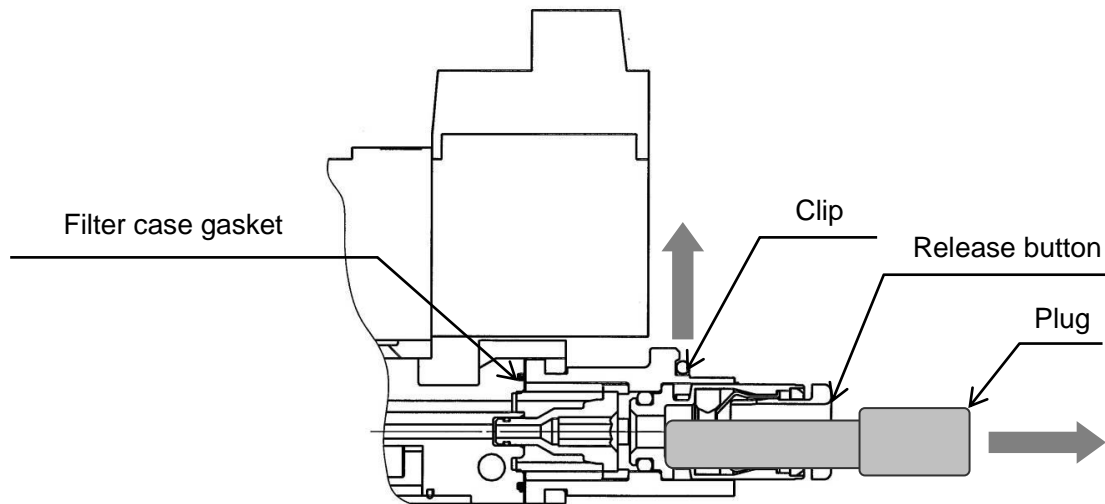

- (8) When removing or inserting the tube from/into the One-touch fitting, hold the body of the One-touch fitting in your hand.

If it is removed or inserted without holding the body of the One-touch fitting, excessive force will be applied to the V port assembly or the One-touch fitting assembly, and it may cause damage and/or air leakage. Also, if a non-axial force is applied to the filter case or break. If load is applied in the bending direction against the axial direction of the filter case, the case may be broken.

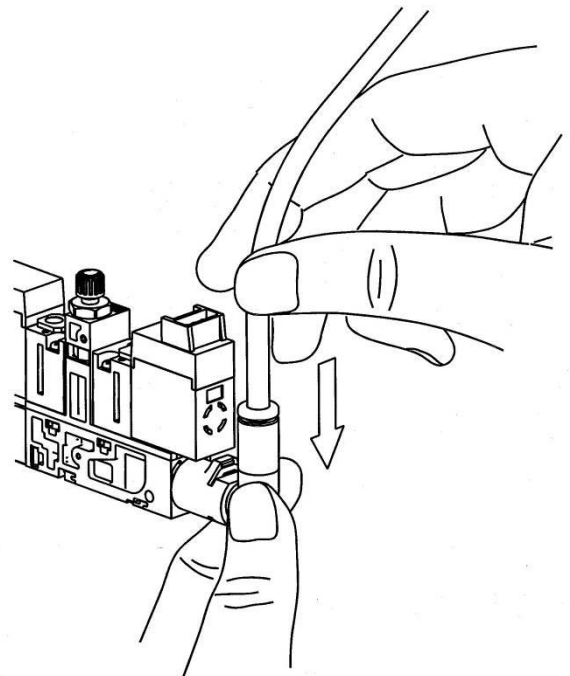
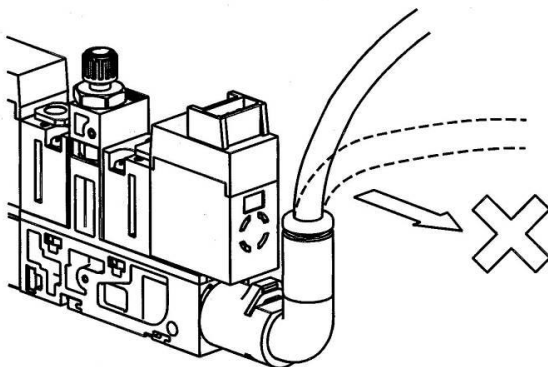

■ One-touch Fittings Precautions

1. Insertion of tube

- 1) Cut the tube perpendicularly, being careful not to damage the external surface. Use SMC's tube cutter TK-1, 2 or 3 for cutting. Do not cut the tube with pliers, nippers, scissors, etc. If the tube is cut by any tools other than a tube cutter, the cut surface of the tube will be slanted or flat, making it difficult to be connected securely, causing the tube to come off or air leakage after the tube is connected. Also, allow a sufficient margin of tube length.
- 2) Hold the tube and push it in slowly, inserting it securely all the way into the fitting.
- 3) After inserting the tubing, pull on it gently to confirm that it will not come out. If it is not installed securely all the way into the fitting, problems such as leakage or disconnection of the tube can occur.

2. Removal of the tube

- 1) KJ series is used for the vacuum (V) port. For this series, the tube can be removed by pushing one part of the release button.
- 2) Hold down the release button while pulling out the tube. If the release button is not held down fully, it will be more difficult to pull out the tube.
- 3) If the removed tubing is to be used again, cut off the section of the tubing which has been gripped. Re-using the gripped portion of the tube can cause problems such as air leakage or difficulty in removing the tube.

■ Precautions for use of other manufacturers' tubes

If tubes of brands other than SMC are used, confirm that the materials and tolerance of the tubing outside diameter will satisfy the following specifications.

- 1) Nylon tube: +/-0.1 mm at max.
- 2) Soft nylon tube Within +/-0.1mm
- 3) Soft polyurethane tube Within +0.15mm or -0.2mm

Do not use tubing which does not meet these outside diameter tolerances. Connection to the fitting may fail, causing disconnection of the tube and air leakage.

■ Tube O.D. $\phi 2$

Tubing other than that from SMC cannot be used, as it may not be possible to connect to the product.

Solenoid Valve

■ Manual Override

Vacuum for the ejector or the vacuum pump system is generated or released by manual operation.

Use the manual override after confirming that there is no danger.

When operating the locking type with a screwdriver, turn it gently using a watchmaker's screwdriver. (Torque: Less than 0.1Nm)

Non-locking push type (Tool required)

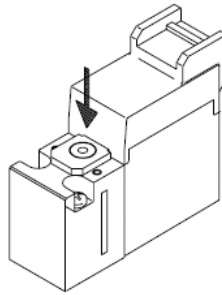

It is turned ON by pressing the manual override all the way in the direction indicated by the arrow (↓), and it is turned OFF by releasing it.

Locking type (Tool required) <Semi-standard>

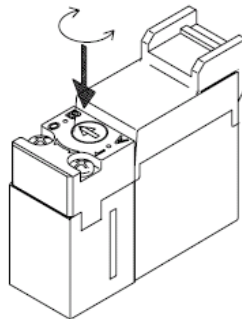

TURN PUSH

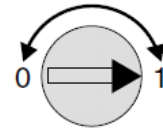

TURN

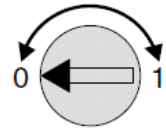

- Turn the manual override to the right and line up the arrow (▶) with 1 to lock in the ON state.
- Turn the manual override to the left and line up the arrow (◀) with 0 to unlock and recover the manual override.

Note) For the locking type manual override, be sure to release the lock before starting the normal operation.

Locking push type (Tool required) <Latching type>

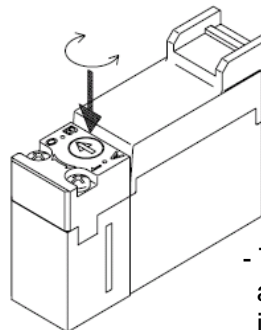

TURN PUSH

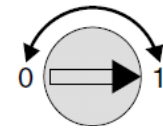

SET

TURN PUSH

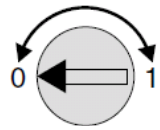

RESET

- Turn the manual override to the right and line up the arrow (▶) with 1 to lock in the SET state (flow from P to A).
- Turn the manual override to the left and line up the arrow (◀) with 0 to return it to the RESET state (flow from A to P). (It is set to RESET state when shipped.)

■ How to Use Plug Connector

Connection and removal of the connector

- To attach a connector, hold the lever and connector unit between your fingers and insert straight onto the pins of the connector adapter so that the lever's pawl is pushed into the groove and locks.

- To detach a connector, remove the pawl from the groove by pushing the lever downward with your thumb, and pull the connector straight out.

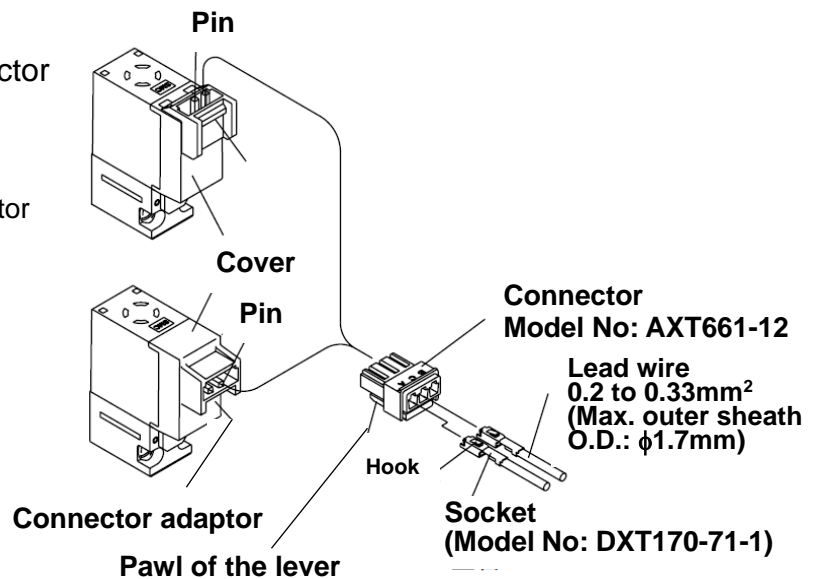

Note) Do not pull the lead wire forcefully. Otherwise, connection failure and broken wire can result.

Crimping lead wires and sockets

Peel 3.2 to 3.7mm of the tip of the lead wire, insert the core wires neatly into the socket and crimp it with a special crimping tool. Make sure the cover of the lead wire does not enter into the core wire crimping part.

(Crimping tool: Model No. DXT170-75-1)

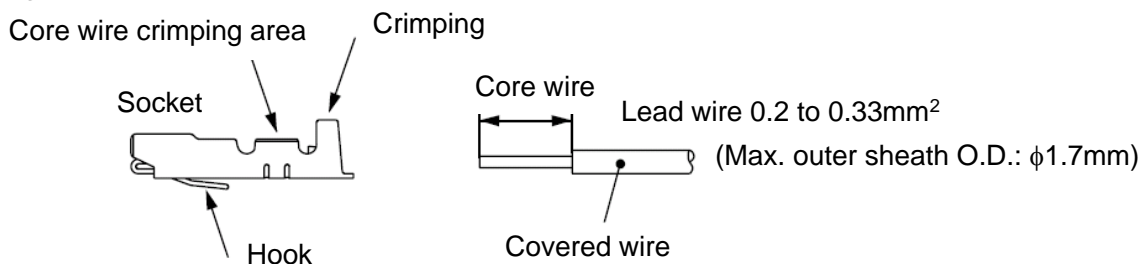

Attaching and detaching sockets with lead wire

- Attaching

Insert the socket into the square hole (indicated as A, C and B) of the connector, push the lead wire in and lock it by engaging the hook of the socket with the seat of the connector. (When it is pushed in, the hook opens and locks automatically.) Then confirm it is locked by gently pulling on the lead wire.

- Detaching

To remove the socket from the connector, pull out the lead wire by pushing the hook on the socket with a stick with a fine point (approximately 1mm). If the socket is to be re-used, open up the hook to the outside.

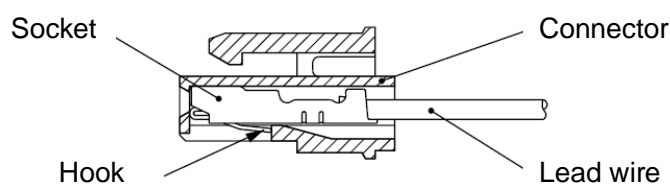

Wiring Specifications

- The lead wire of the solenoid valve is connected as shown below. Connect each wire to the corresponding wire of the power supply.

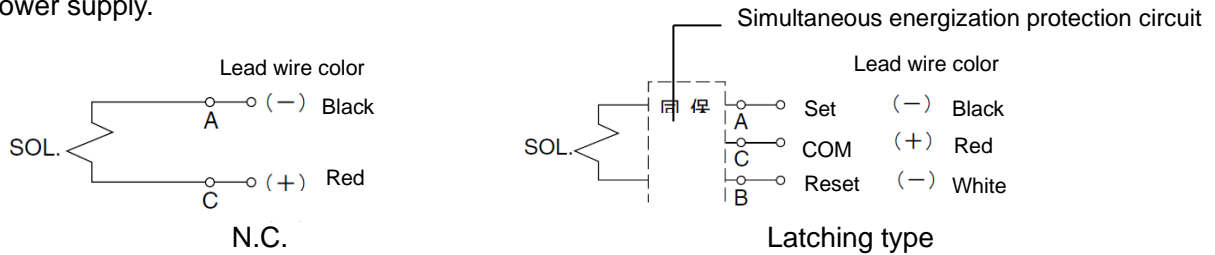

- Plug Connector Lead Wire Length

Lead wire length of the solenoid valve with lead wire is 300mm. When placing an order for the solenoid valve with the lead wire which length is 600mm or longer, include the connector assembly part number together with the part number for the solenoid valve without connector.

■ Light/Surge voltage suppressor

In the latching type, the set side (Vacuum ON) and the reset side (Vacuum OFF) energization are indicated by two colors - orange and green.

* The dotted lines indicate the latching and large flow type.

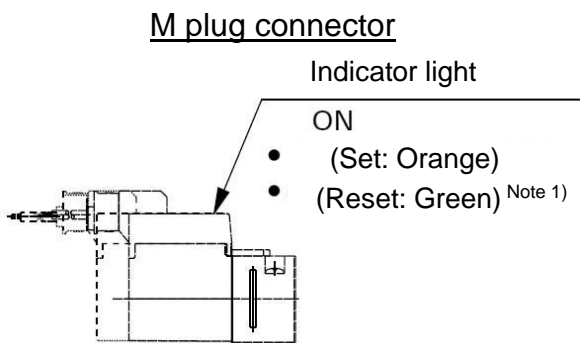

Single type (N.C.)

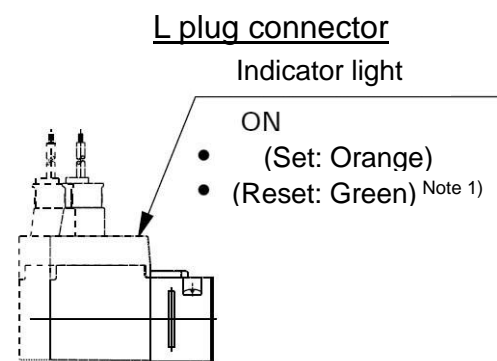
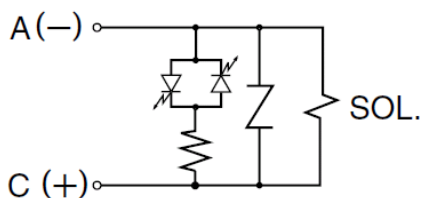

Latching type (DC + common)

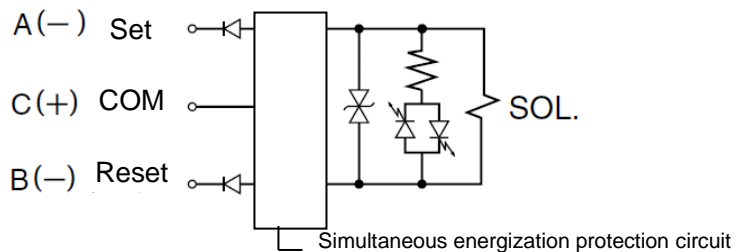

Note 1) Only the latching type has the reset function.

Note 2) NC type has polarity. ON: The orange light turns ON.

Note 3) Set side energization: orange light turns ON, Reset side energization: green light turns ON, with incorrect wiring prevention (stop diode) mechanism.

Note 4) Energization on A (set) side generates vacuum and energization on B (reset) side stops generation of vacuum.

■ How to operate the supply valve of the latching type

Latching type refers to a solenoid with a self holding mechanism. It has a construction whereby the moving armature in the solenoid holds the set position and the reset position during momentary energizing (20ms or longer). Therefore, continuous energizing is not necessary.

<<Cautions for latching type>>

1. Use in a circuit in which set and reset signals are not energized simultaneously.
2. Minimum necessary energizing time for self holding is 20 ms.
3. There is no problem as long as the product is used normally in an ordinary operating location. If the product is used in an environment where strong vibration, impact or magnetic field is present, it may cause malfunctions.
4. Although this supply valve holds reset position (Vacuum stop) when shipped, it may move to set (Vacuum generation) position due to impact during transportation or valve mounting. Confirm the original position before use, by supplying power or by manual operation.

Latching	Operation	Indicator light
A-C ON (Set)	Vacuum generation	Orange
B-C ON (Reset)	Vacuum stop	Green

N.C.	Operation	Indicator light
A-C ON (Set)	Vacuum generation	Orange
OFF	Vacuum stop	—

If the supply valve is latching type, continuous energization is not necessary because it maintains the switching position with momentary energization for at least 20 msec. Depending on the conditions, continuous energizing may cause operation failure such as ON operation failure due to operation voltage increase caused by coil temperature rise.

When continuous energizing is necessary, the energizing time shall be 10 minutes or shorter. Before the next operation, the solenoid shall be de-energized (both A side and B side OFF) for longer than the energized time. (Duty ratio shall be 50% or less.)

■ Do NOT energize the solenoid valve for a long time.

If a solenoid valve is continuously energized for an extended period of time, heat generated by the coil may result in reduced performance or have adverse effects on peripheral equipment. If the total energizing time per day is presently longer than the total de-energizing time per day, a latching type solenoid valve can be used to reduce this energization time. Do not energize to the coils on both the A and B sides at the same time when using the latching type.

The solenoid valve should not be energized continuously for longer than 10 minutes, and the energizing time in one day should be shorter than the non-energizing time. (The duty ratio should be 50% at maximum.) When the valve is mounted onto a control panel, take measures against heat radiation in order to keep the valve temperature within the specified range. In particular, if three or more adjacent stations on the manifold are energized together for extended periods of time, the temperature rise will be greater.

Construction

Construction of ZB Series

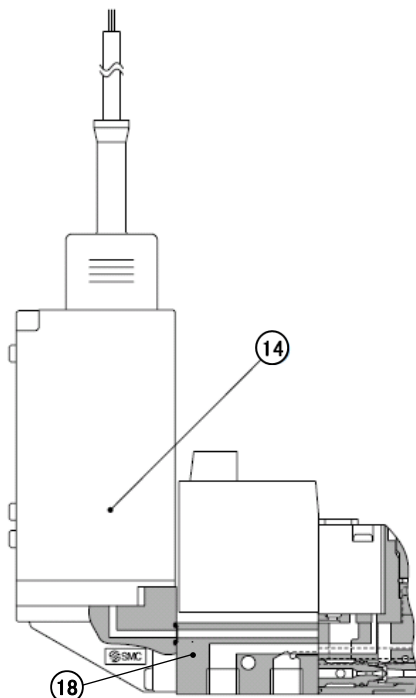

Single unit/With vacuum pressure switch

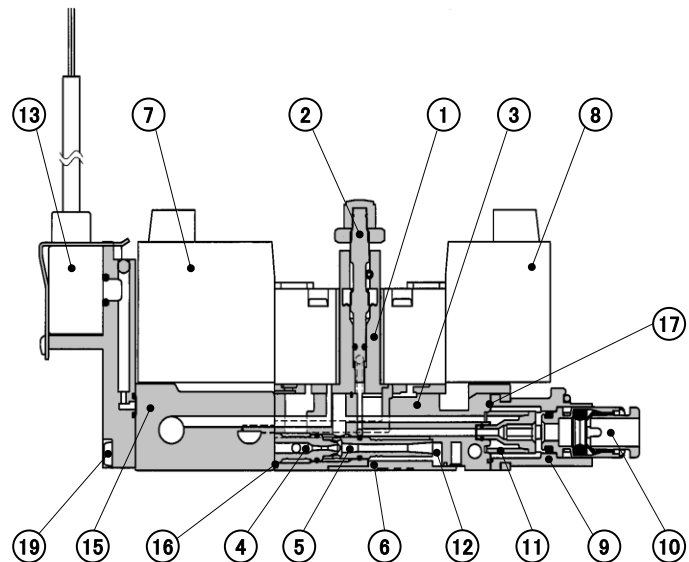

Manifold/With pressure sensor

Components

No.	Item	Main parts material	Remarks
(1)	Valve body assembly	Resin/HNBR	Solenoid valve mounting part
(2)	Needle assembly	Resin/ Brass/ NBR	For adjusting release flow, with lock nut retaining mechanism
(3)	Body	Resin	Bodies for ejector and for pump system both available.
(4)	Nozzle	Aluminum	For vacuum pump system: Spacer
(5)	Diffuser	Aluminum	For vacuum pump system: No diffuser
(6)	Silencer cover	Resin	

The components from (7) to (19) are available as service parts. Refer to “Maintenance and Check” on the next pages for details.

Maintenance

■ Implement the maintenance and check shown below in order to use the ejector and the vacuum system safely and in an appropriate way for a long period of time.

- 1) Maintenance should be performed according to the procedure indicated in the Operation Manual.
Improper handling can cause damage and malfunction of equipment and machinery.
- 2) Maintenance work
Compressed air can be dangerous when handled incorrectly. Therefore, in addition to observing the product specifications, replacement of elements and other maintenance activities should be performed by personnel with sufficient knowledge and experience pertaining to pneumatic equipment.
- 3) Draining
Remove condensate from air filters and mist separators regularly. If the collected drainage is drained to the downstream side, it can stick inside of the product, causing operation failure and failure to reach the specified vacuum pressure.
- 4) Replace the filter element built into the ejector and the vacuum pump system and the silencer regularly. (Refer to the replacement procedure below.)
It is recommended to replace the filter element and the silencer when the pressure drop reaches 5kPa as a guideline. The replacement cycle varies depending on the operating conditions, operating environment and supply air quality.
However, if there is a vacuum pressure drop and/or delay in the vacuum (adsorption) response time which causes problem with the settings during operation, stop the operation of the product and replace the element regardless of the above mentioned replacement guideline.
- 5) Operation in an environment where there is a lot of dust in the air
The processing capacity of the filter element built into the product may be insufficient. It is recommended to use SMC's air suction filter (ZFA, ZFB, ZFC series) in order to avoid problems beforehand.
- 6) Check before and after the maintenance work
When the product is to be removed, turn off the power supply, and be sure to cut off the supply pressure and exhaust the compressed air. Confirm that the air is released to atmosphere.
When mounting the product after the maintenance work, supply compressed air, connect to the power, check if it functions properly and have a leakage inspection. Especially for the latching type supply valve, be sure to check that the supply valve is OFF in the initial condition because it is possible that it is ON due to vibration.
- 7) Do not disassemble or modify the product, other than the replacement parts specified in this manual.

■ Replacement Parts

No.	Description [Application]	Model	Remarks
(7)	Supply valve [Generates vacuum.]	ZB1-VQ110U-□□□	N.C. : Supply valve for ejector (Applicable nozzle sizes: 0.3, 0.4, 0.5, 0.6)
		ZB1-VQ110L-□□□	Latching : Supply valve for ejector (Applicable nozzle sizes: 0.3 and 0.4)
		ZB1-VQ120U-□□□	N.C. : Supply valve for vacuum pump system
(8)	Release valve [Releases vacuum]	ZB1-VQ110-□□□	N.C.
(9)	V port assembly [For vacuum port]	ZB1-VPN3-□-A	Material : Transparent special nylon One-touch tube fitting, with filter element
(10)	One-touch fitting	KJ□□-C1	Only the One-touch tube fitting should be replaced.
(11)	Filter element [For suction filter]	ZB1-FE3-A	Filtration rating: 30μm, 10 elements in one set
(12)	Silencer [For silencer]	ZB1-SE1-A	10 silencers in one set
(13)	Pressure sensor assembly	ZB1-PS□-A	
(14)	Pressure switch assembly for vacuum	ZB1-ZS□□□□-A	
(15)	Manifold base assembly	ZZB□-□□□	For changing the number of stations
(16)	Gasket	ZB1-GK1-A	10 pcs. per set
(17)	Filter case gasket	ZB1-FG1-A	10 pcs. per set
(18)	Body assembly for single unit	ZB1-SB□-A	Without pressure sensor/switch, 2 mounting screws (M2 x 26) are included.
		ZB1-SBS□-A	With pressure sensor/switch, 2 mounting screws (M2 x 30) are included.
(19)	Mounting screws	ZB1-SR1-1-A	Without pressure sensor/switch, 10 pcs. per set
		ZB1-SR1-2-A	With pressure sensor/switch, 10 pcs. per set

■ Model Indication of the Replacement Parts

(7) Supply valve, (8) Release valve

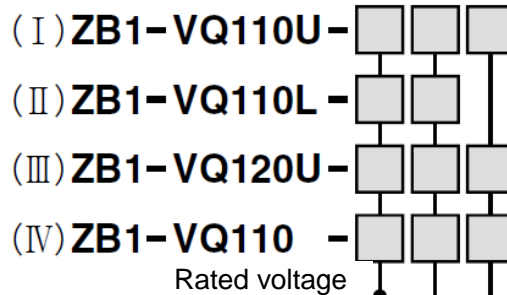

Rated voltage	
5	24 VDC
6	12 VDC

Electrical entry

L	L plug connector with lead wire
LO	L plug connector without lead wire
M	M plug connector with lead wire <small>Note 2)</small>
MO	M plug connector without lead wire <small>Note 2)</small>

Note 1) All with light and surge suppressor. Lead wire length is 300mm for the models with lead wire. For other lead wire lengths, select a model without connector and include the connector assembly part number.

Note 2) M plug connector is not available with the model with pressure sensor.

Manual override Note 3)

NIL	Non-locking push type
B	Locking type (Tool required) Semi-standard

Note 3) Only the push locking type (no symbol) is available for the latching

Note 4) Refer to Table 3 for the accessory.

Table 1. Combination of the supply valve and the release valve

* The applicable supply valve specification varies depending on the nozzle size of the ejector.

* The symbols in the table correspond to the supply valves/ release valves shown on the left.

Symbol	Supply valve and release valve Specifications		Ejector								Pump system	
			ZB03		ZB04		ZB05		ZB06		ZB00	
	Supply valve	Release valve	Supply valve	Release valve	Supply valve	Release valve	Supply valve	Release valve	Supply valve	Release valve	Supply valve	Release valve
K1	N.C	N.C	(I)	(IV)	(I)	(IV)	(I)	(IV)	(I)	(IV)	(III)	(IV)
J1	N.C	Not provided	(I)	/	(I)	/	(I)	/	(I)	/	(III)	/
Q1	Latching	N.C	(II)	(IV)	(II)	(IV)	/	/	/	/	/	/
Q2	Latching	Not provided	(II)	/	(II)	/	/	/	/	/	/	/

● Part No. for the connector assembly and accessories

Table 2. Part No. for connector assembly

AXT661 - -

Applicable supply/ release valve Lead wire length (mm)

14A	(I), (III), (IV) (DC + common, single)	NIL	300
		6	600
		10	1000
		20	2000
		30	3000
13A	(II) (DC + common, latching)		

Table 3. Accessories to supply valve/ release valve

Model	Accessories
ZB1-VQ110U-□□	Mounting screws (M1.7 x 15); 2pcs.
ZB1-VQ110U-□□B	Mounting screws (M1.7 x 22); 2pcs.
ZB1-VQ110L-□□	Mounting screws (M1.7 x 22); 2pcs.
ZB1-VQ120U-□□	Mounting screws (M1.7 x 15); 2pcs.
ZB1-VQ120U-□□B	Mounting screws (M1.7 x 22); 2pcs.
ZB1-VQ110-□□	Mounting screws (M1.7 x 15); 2pcs.
ZB1-VQ110-□□B	Mounting screws (M1.7 x 22); 2pcs.

(9) V port assembly

ZB1 - VPN3 - C2 - A

● One-touch tube fitting

C2	Straight type $\phi 2$ One-touch tube fitting	Metric size
C4	Straight type $\phi 4$ One-touch tube fitting	
N1	Straight type $\phi 1/8$ " One-touch tube fitting	Inch size
N3	Straight type $\phi 5/32$ " One-touch tube fitting	
L2	Elbow type $\phi 2$ One-touch tube fitting	Metric size
L4	Elbow type $\phi 4$ One-touch tube fitting	
LN1	Elbow type $\phi 1/8$ " One-touch tube fitting	Inch size
LN3	Elbow type $\phi 5/32$ " One-touch tube fitting	

(10) One-touch tube fitting (10 in one set)

KJ **H** **04** - **C1**

Body type Port size

H	Straight	02	φ2 One-touch tube fitting	Metric size
L	Elbow	04	φ4 One-touch tube fitting	
		01	φ1/8" One-touch tube fitting	Inch size
		03	φ5/32" One-touch tube fitting	

* For the combination of the elbow type body and the One-touch tube fitting φ4, add the suffix “-N” to the part number.

KJL04-C1-N

(11) Filter element (10 in one set)

ZB1-FE3-A (Filtration rating: 30 μm)

(12) Silencer (10 in one set)

ZB1-SE1-A

(13) Pressure sensor assembly

ZB1-PS **1** - **A**

Pressure sensor specification

1	0 to -101kPa, Output 1 to 5V Accuracy: +/-2% F.S. at max.	Identification symbol ZA
3	-100 to 100kPa, Output 1 to 5V Accuracy: +/-2% F.S. at max.	Identification symbol FA

* Lead wire length: 3m

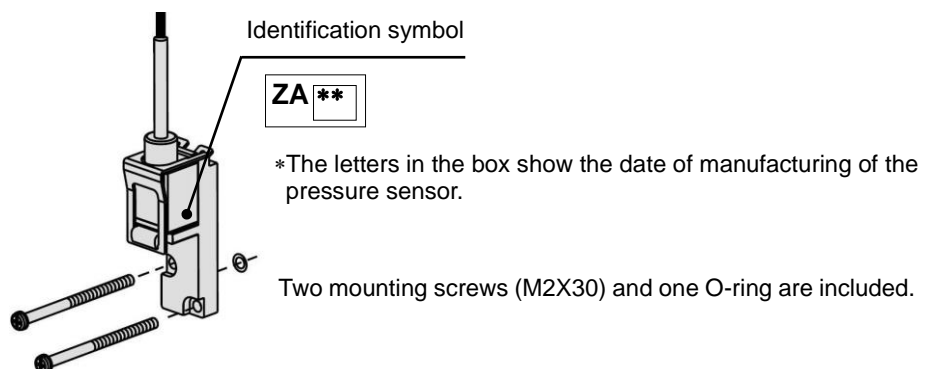

(14) Pressure switch assembly for vacuum

* If only the lead wire with connector is required order part number ZS-39-5G.

* If only the lead wire with connector for IO-Link pressure switch is required order part number ZB1-LW07-A.

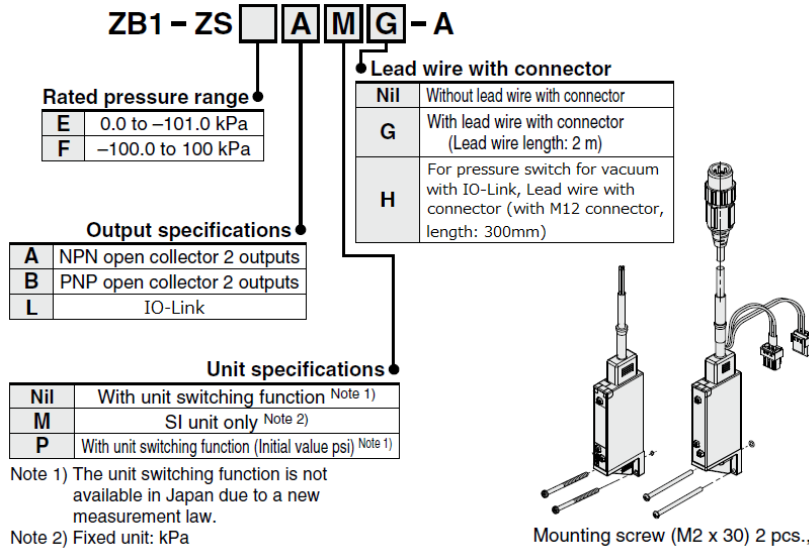
**Replacement Procedure for Filter Element**

- Hold the V port assembly with your fingers, and turn it 45 degrees in the counter-clockwise direction and pull it out.

For the straight type One-touch tube fitting, it can be removed by using a hexagon wrench (width across flats: 2).

- Remove the filter element from the removed filter case, and mount a new filter element securely to the back of the case. (See Fig. to the right)

- Confirm that the filter case gasket is not displaced and that it has no foreign matter stuck to it.

- Insert the V port assembly into the ejector/vacuum pump system (Fig. to the right), press it slightly and turn it for approximately 45 degrees in the clockwise direction until it stops. (See Fig. to the right)

(Mount the V port assembly in the direction specified in the figure. If the convex side is mounted downward, it will interfere with the floor when the element is mounted on its bottom surface, causing breakage of the filter case and the element.)

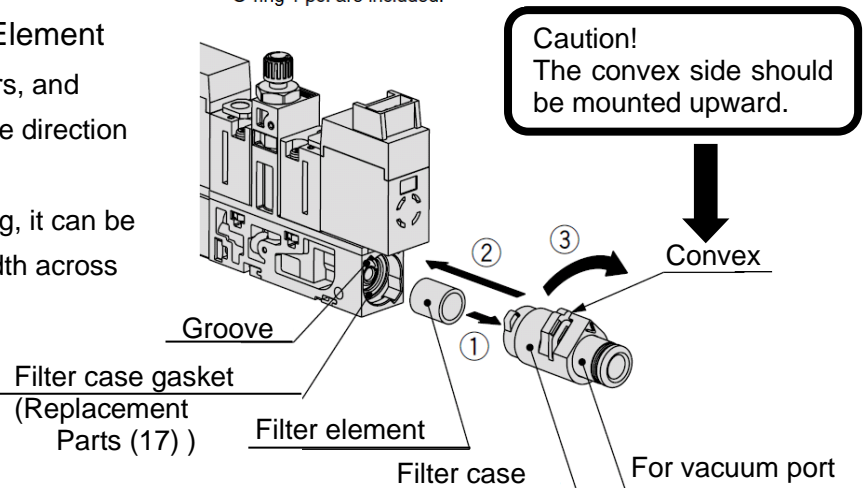

■ Replacement procedure for silencer*

- Turn the body upside down. Apply a watchmaker's screw driver or your finger to the notch, and slide the silencer cover in the direction indicated by the \triangle mark.
 - When it clicks, the hook is disconnected. Put your Pry up and remove part A, cover.
 - Remove the silencer by using a watchmaker's screw driver.
 - Insert a new silencer, and mount the cover by the reverse procedure of the disassembly procedure for reassembly.
- (When replacing the silencer, the metal diffuser can be seen. This part is important to the function. Do not touch or apply force to the metal diffuser when replacing the silencer.)

* For vacuum pump system, the silencer is not built in.

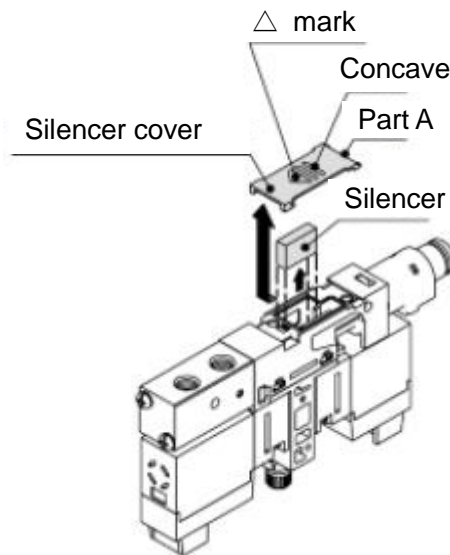

■ Replacement procedure for solenoid valve (supply valve, release valve)

-This product has a "supply valve" for generating vacuum and a "release valve" for releasing vacuum. Follow the procedure below to replace the solenoid valves after the product has been used for a long period of time or malfunctions.

- 1) Remove the mounting screws of the solenoid valve.
- 2) Remove the solenoid valve.
- 3) Before mounting the replacement solenoid valve, check that it has no dust or scratches on the mounting surface.

Be certain that the gasket and filter element R of the supply valve are properly mounted as well.

(Filter element R is installed in the supply valve only.)

- 4) Tighten the mounting screw of the solenoid valve to the specified torque below.

Appropriate tightening torque (Nm)	0.054 to 0.08
------------------------------------	---------------

- When replacing the solenoid valves, the valve body will come off if both the supply valve and the release valve are removed at the same time. Removal and mounting of the solenoid valves should be done one at a time to prevent parts from dropping and foreign matter from entering.

* Function of the filter element R: When the supply valve is switched OFF from ON, atmospheric pressure flows from the vent port into the space inside the valve where there is "vacuum pressure". Filter element R is a filter mounted in the flow path. It prevents the dust in the operating environment from entering inside the solenoid valve.

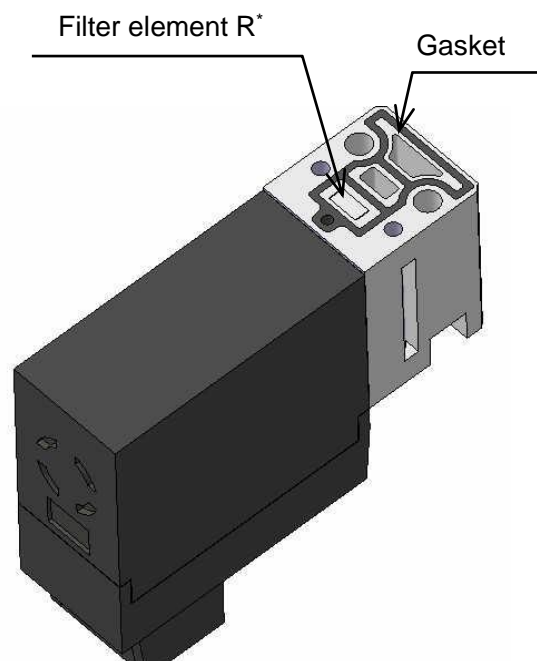
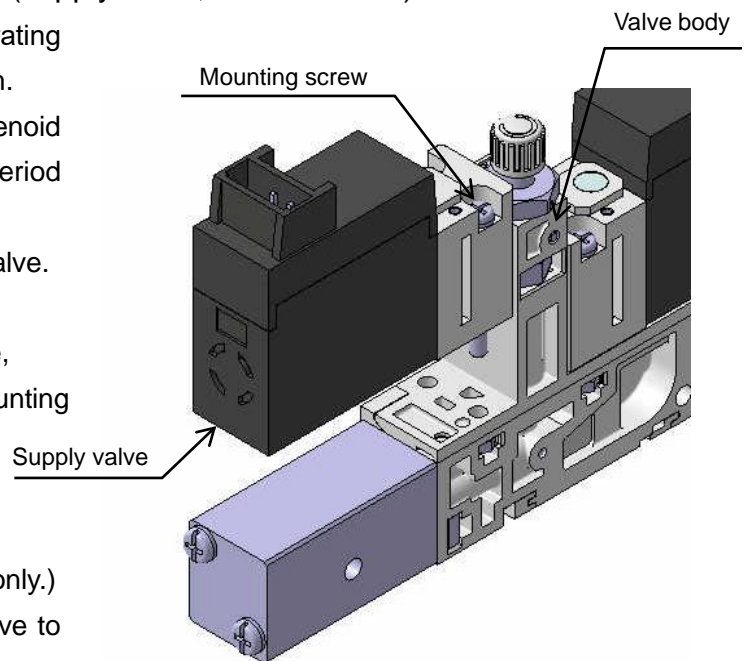

B

Manifold Products

Increasing and Decreasing the Number of Manifold Stations

- When decreasing the number of manifold stations, order the manifold base (a) exclusive for the required number of stations. When increasing the number of stations, order the required number of single units of the body type 3 valve (b).

Refer to Model Indication and How to Order (pages from 10 to 14) for the part numbers for placing an order. The part number for the manifold base is different depending on whether pressure sensor/ vacuum pressure switch are mountable or not.

- When mounting each station, check that all the gaskets are in place and tighten the screws to the specified torque.

If the tightening torque is exceeded, the body can be broken.

Appropriate tightening torque (Nm)	0.075 to 0.096
------------------------------------	----------------

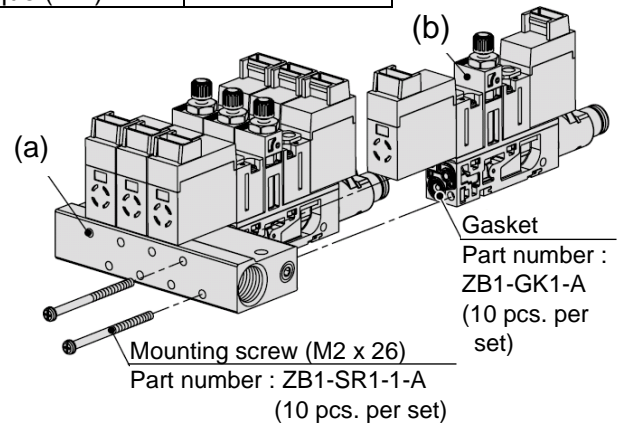

- For the manifold with pressure sensor/vacuum pressure switch, order the manifold base (a) for the required number of stations. When increasing the number of stations, order the required number of single unit of the body type 3 valve (b) and the required number of either the pressure sensor assembly (c) or the vacuum pressures switch assembly (d).

- In this case, the pressure sensor (c) /vacuum pressure switch (d) is tightened together with the single unit of the product (b). (Refer to the figure on the right.)

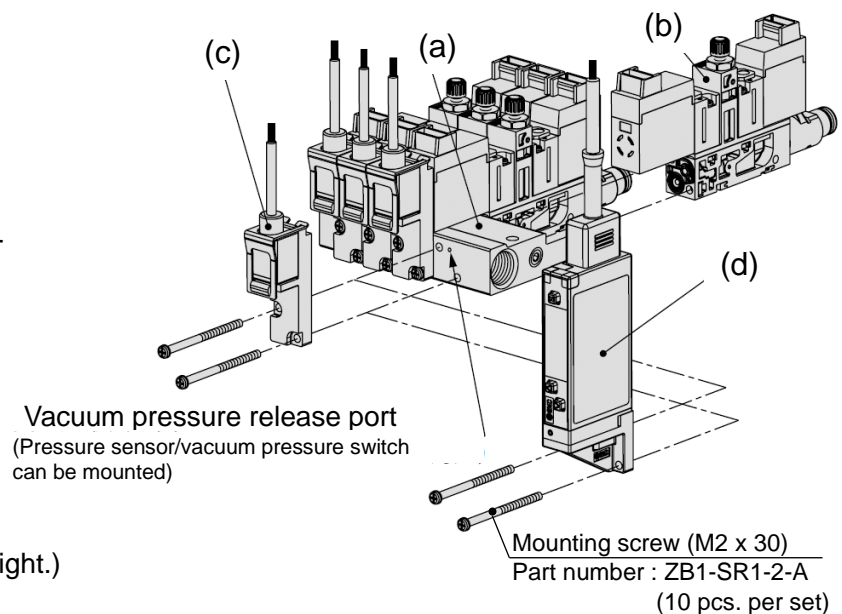

- When mounting the pressure sensor/ vacuum pressure switch, be sure to check that the O-ring on the mounting surface of the manifold base is mounted properly and that the O-ring is not displaced from the mounting groove. If the O-ring is not mounted properly, it can cause vacuum pressure leakage.

Filter Case

- Special transparent filter case made of nylon

Do not use in an environment where chemicals such as alcohol are present and where they could stick to the filter case.

Vacuum Release Flow Adjustment Needle

- Vacuum release flow characteristics

The graph on the right shows the flow characteristics with various supply pressures when the vacuum release flow adjustment needle is opened from the fully close state “n” turns.

However, the flow characteristics shown in this graph are represent values of the single unit of the product. The flow at the absorption part may vary depending on the piping conditions to the vacuum (V) port, circuit etc. The flow characteristics and the number of rotations of the needle vary due to the range of the specifications of the product.

- This product has a needle retaining mechanism.

The needle stops rotating when it reaches the rotation stop position.

It may damage the product if the needle is rotated past its stop position.

- Do not tighten the needle any more after it reaches the fully closed position (fully Clockwise).

The fully closed position is when the end of the needle touches the resin hole. If it is tightened any more after the needle reaches the position where it stops, the resin part will be deformed, causing breakage.

- Do not tighten the needle handle with tools such as pliers.

This can result in breakage due to over torquing.

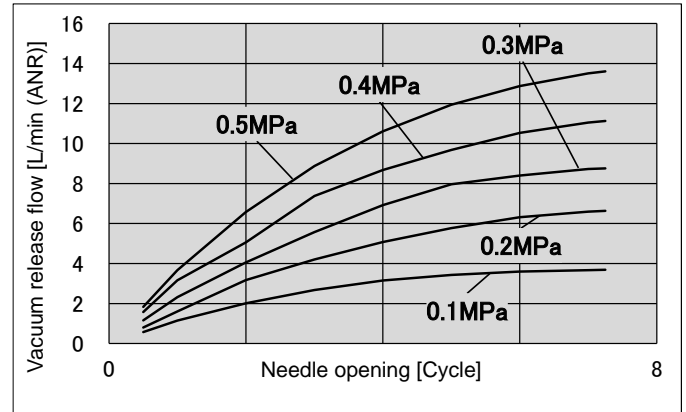

Exhaust from Ejector

- Avoid back pressure being applied to the exhaust air of the ejector.

The exhaust resistance (back pressure) should be as little as possible to obtain the full ejector performance.

There should be no shield around the exhaust port. The port exhaust specification for back pressure should be 0.005MPa (5kPa) at maximum., Exhaust resistance is generated with some piping bore sizes and piping lengths. For tube ID $\phi 4$, as a guideline, it is recommended to make the piping length 1000mm at maximum, although it varies depending on the condition of the equipment at the end.

For the silencer exhaust specification, the silencer will gradually get clogged if dust in the operating environment is sucked in or if the supply air is not clean enough. If the silencer becomes clogged, back pressure is applied to the ejector exhaust which results in a reduction in the vacuum pressure and the adsorption flow rate.

It is recommended to replace the silencer with a new one when the vacuum pressure of the ejector decreases or a delay in response time is generated. (See page 37)

Specifications

General Specifications

Ambient temperature range	-5 to 50°C (No condensation)
Fluid	Air, inert gas
Vibration resistance <small>Note 1)</small>	30m/s ² (Without pressures sensor/vacuum pressure switch, With pressure sensor) 20m/s ² (With switch)
Impact resistance <small>Note 2)</small>	150m/s ² (Without pressures sensor/vacuum pressure switch, With pressure sensor) 100m/s ² (With switch)
Standard	CE/UKCA Marking (EMC,RoHS)

Note 1) 10 to 500Hz for 2 hours in each direction, X, Y and Z (No malfunction found as a result of the tests in every direction while energized and de-energized.)

Note 2) No malfunction was found after the tests as a result of the test in every direction, X, Y and Z three times while de-energized.

Common Specifications for Supply Valve and Release Valve

Valve construction	3-port direct operated poppet valve
Lubrication	Not required
Manual override <small>Note 1)</small>	Non-locking push type/ Locking type (Tool required)
Enclosure protection	Dustproof

Note 1) Only the push-lock type is available for latching type.

Specifications for Supply Valve and Release Valve

Type	Supply valve			Release valve	
	Large flow type		Latching type	Standard type	
Part No. of Supply valve and release valve	ZB1-VQ110U-□	ZB1-VQ120U-□	ZB1-VQ110L-□	ZB1-VQ110-□	
Applicable system	Ejector (N.C.)	Pump system (N.C.)	Ejector Note 1)	Ejector (N.C.) Pump system (N.C.)	
Maximum operating pressure	0.55MPa	0.1MPa	0.55MPa	0.55MPa	
Minimum operating pressure	0.1MPa	-0.1MPa	0.1MPa	0MPa	
Response time	5ms or less	5ms or less	5ms or less	ON: 3.5ms, OFF: 2ms	
Coil rated voltage Power consumption (Current)	24VDC	0.7W (29mA) Note 2)	0.7W (29mA) Note 2)	1W (42mA)	1W (42mA)
	12VDC	0.7W (58mA) Note 2)	0.7W (58mA) Note 2)	1W (83mA)	1W (83mA)
Electrical entry	L type plug connector (with light and surge voltage suppressor) M type plug connector (with light and surge voltage suppressor) Note 3)				

Note 1) Latching type is applicable only to the ejector nozzle I.D. 0.3 and 0.4.

Note 2) 3.1W when starting up (for 10ms after starting energization), 0.7W when holding

Note 3) M type can also be selected when the ejector or the vacuum pump system is selected without pressure sensor/ vacuum pressure switch.

Ejector Specifications ^{Note 1)}

Model	ZB03		ZB04		ZB05	ZB06
Supply valve type	Large flow (N.C.)	Latching	Large flow (N.C.)	Latching	Large flow (N.C.)	Large flow (N.C.)
Nozzle I.D. mm	0.3		0.4		0.5	0.6
Supply pressure range ^{Note 2)} MPa	0.2 to 0.55					0.3 to 0.55
Standard supply pressure MPa	0.35	0.4	0.35	0.45	0.35	0.5
Air consumption L/min (ANR)	3.5	4	6.5	8.5	10	18
Max. suction flow L/min (ANR)	2		3.5		4.5	7
Max. vacuum pressure kPa	-86		-90			

Note 1) The values in the table are typical values, and they can vary depending on the atmospheric pressure (weather change and altitude of the operating location) where the product is used.

Note 2) The maximum operating pressure is 0.5MPa when using the product either with pressure sensor or vacuum pressure switch.

■ Suction Filter Specifications

Filtration rating	30 μ m
Filtration area	130mm ²

■ Pressure sensor specifications/ ZB1-PS□-A

Model (Sensing part: Standard model)		ZB1-PS1-A (PSE541)	ZB1-PS3-A (PSE543)
Rated pressure range		0 to -101kPa	-100 to 100kPa
Proof pressure		500kPa	
Output voltage		1 to 5V DC	
Output impedance		Approx. 1 k Ω	
Power supply voltage		12 to 24 VDC \pm 10%, ripple (P-P) 10% at max.	
Current consumption		15mA or less	
Accuracy		\pm 2%F.S. (at an ambient temperature of 25 °C)	
Linearity		\pm 0.4% F.S. or less	
Repeatability		\pm 0.2% F.S. or less	
Effect of power supply voltage		\pm 0.8% F.S. or less	
Temperature characteristics		\pm 2%F.S. or less (at an ambient temperature of 25 °C as standard)	
Material	Case	Resin case	
	Pressure sensing part	Pressure receiving part of the pressure sensor: Silicone, O-ring: HNBR	
Lead wire		Oilproof heavy-duty vinyl cable Oval 2.7 x 3.2mm, cross section of conductor: 0.15mm ² , 3-wire for 3m, insulator O.D.: 0.9mm	

Note 1) Refer to the General Specifications on P.41 for the specifications not shown in this table.

■ Pressure switch for vacuum/ZB1-ZS□□□□-A

(For the pressure switch for IO-Link Specifications, refer to the ZB1-ZS□L□□-A Operation Manual.)

Model (Sensing part: Standard model)	ZB1-ZSE□□□□-A (ZSE10)	ZB1-ZSF□□□□-A (ZSE10F)
Rated pressure range	0 to -101kPa	-100 to 100kPa
Set pressure range/ Pressure display range	10 to -105kPa	-105 to 105kPa
Proof pressure	500kPa	
Min. setting unit	0.1kPa	
Power supply voltage	12 to 24 VDC $\pm 10\%$, ripple (P-P) 10% at max. (with polarity protection)	
Current consumption	40mA or less	
Switch output	NPN or PNP open collector 2 outputs (To be selected)	
Maximum load current	80mA	
Max. applied voltage	28V (NPN output)	
Residual voltage	Max. 2V (at 80mA load current)	
Response time	2.5 ms or less (response time available for anti-chattering function: 20, 100, 500, 1000 or 2000 ms)	
Short circuit protection	Provided	
Repeatability	$\pm 0.2\%$ F.S., ± 1 digit	
Hysteresis	Hysteresis mode	Adjustable (can be set from 0) ^{Note 1)}
	Window comparator mode	
Display type	3 1/2 digits, 7-segment LED 1-color display (red)	
Display accuracy	$\pm 2\%$ F.S., ± 1 digit (at ambient temperature 25 ± 3 Celcius)	
Indication LED	Lights up when ON OUT1: Green, OUT2: Red.	
Environmental resistance	Enclosure	IP40
	Operating humidity	Operation, Storage: 35 to 85% RH (No condensation)
	Withstand voltage	1000 VAC for 1 minute between terminals and housing
	Insulation resistance	50M Ω or more between terminals and housing (with 500 VDC megger)
Temperature characteristics	$\pm 2\%$ F.S. (at 25°C in the operating temperature range between -5 and 50°C)	
Lead wire	Oilproof heavy-duty vinyl cable Cross section of conductor: 0.15mm ² (AWG26), 5-wire for 2m, insulator O.D.: 1.0mm	

Note 1) If the applied voltage fluctuates around the set value, the hysteresis must be set to a value more than the fluctuating width, otherwise chattering will occur.

Note 2) Refer to the General Specifications on P.41 for the specifications not shown in this table.

Internal circuit and wiring examples

(For the pressure switch for IO-Link Specifications, refer to the ZB1-ZS□L□□-A Operation Manual.)

Pressure sensor

ZB1-PS□-A

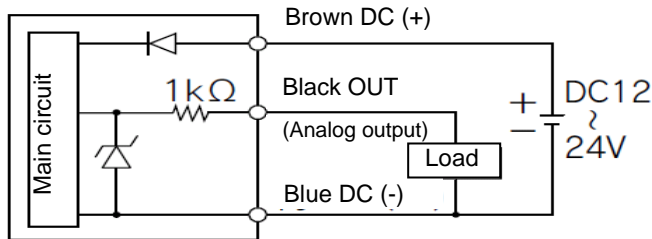

Voltage output type 1 to 5V
Output impedance approx. 1kΩ

Vacuum pressure switch

ZB1-ZS□A□□-A

NPN (2 outputs)

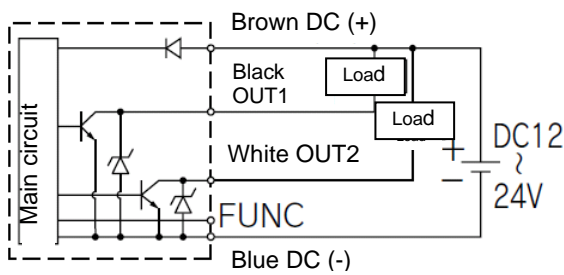

Max.28V, 80mA
Residual voltage 2V or less

ZB1-ZS□B□□-A

PNP (2 outputs)

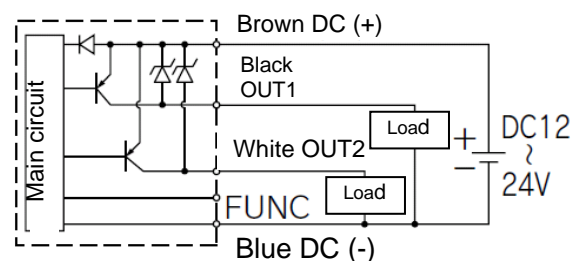

Max.80mA
Residual voltage 2V or less

NPN(2出力)

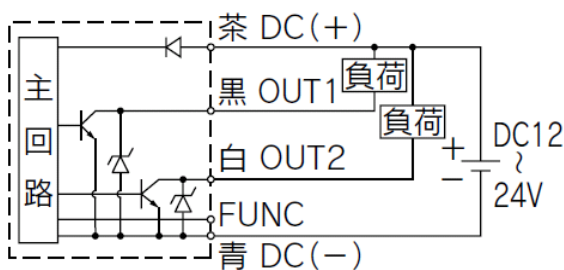

Max.28V, 80mA
残留電圧2V以下

Circuit Diagram

■ Specifications of a Single Unit

With supply valve/release valve, without pressure sensor/vacuum pressure switch

Ejector PV=PD

ZB□11-K1□□□-□

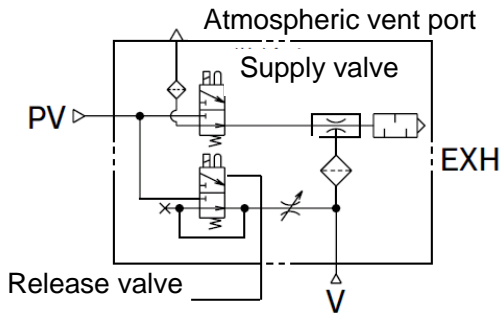

Vacuum pump system PV≠PD

ZB0020-K1□□□-□

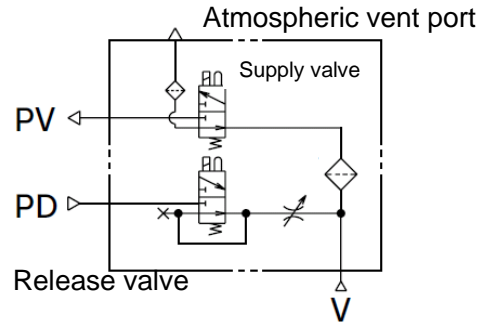

Supply valve only, Without pressure sensor/ vacuum pressure switch

Ejector PV only

ZB□11-J1□□□-□

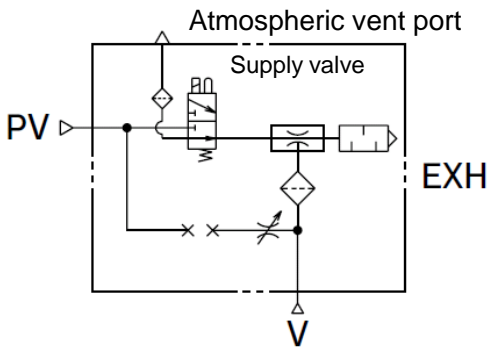

Vacuum pump system PV only

ZB0010-J1□□□-□

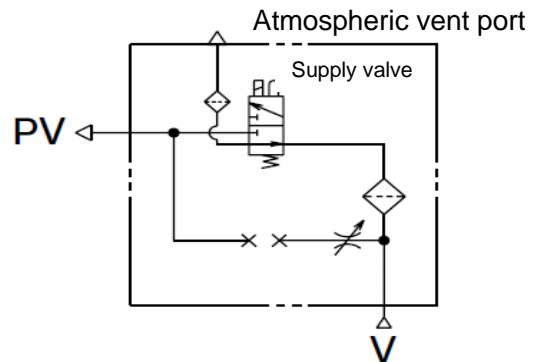

With supply valve/ release valve, with pressure sensor

Ejector PV≠PD

ZB□21-Q1□L(O)□-P₃¹-□

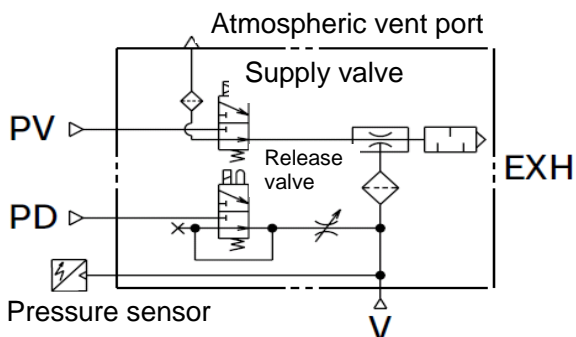

Vacuum pump system PV≠PD

ZB0020-K1□L(O)□-P₃¹-□

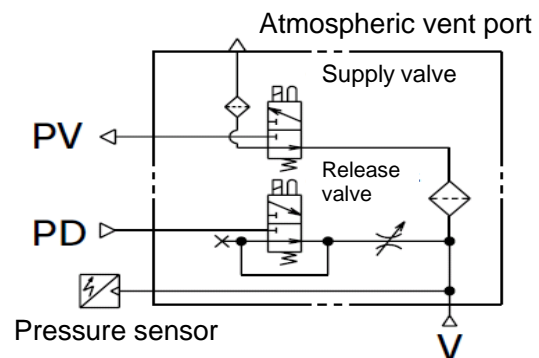

Manifold Specifications

With supply valve/ release valve, Without pressure sensor/ vacuum pressure switch

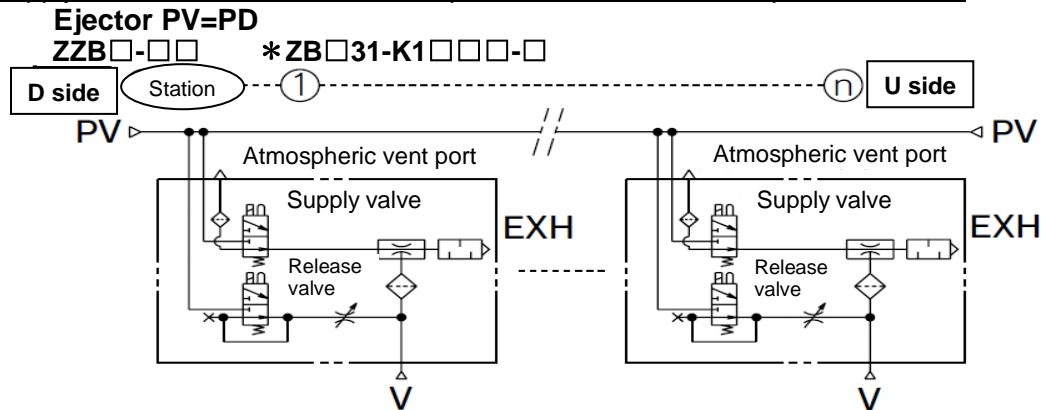

With supply valve/ release valve, with vacuum pressure switch

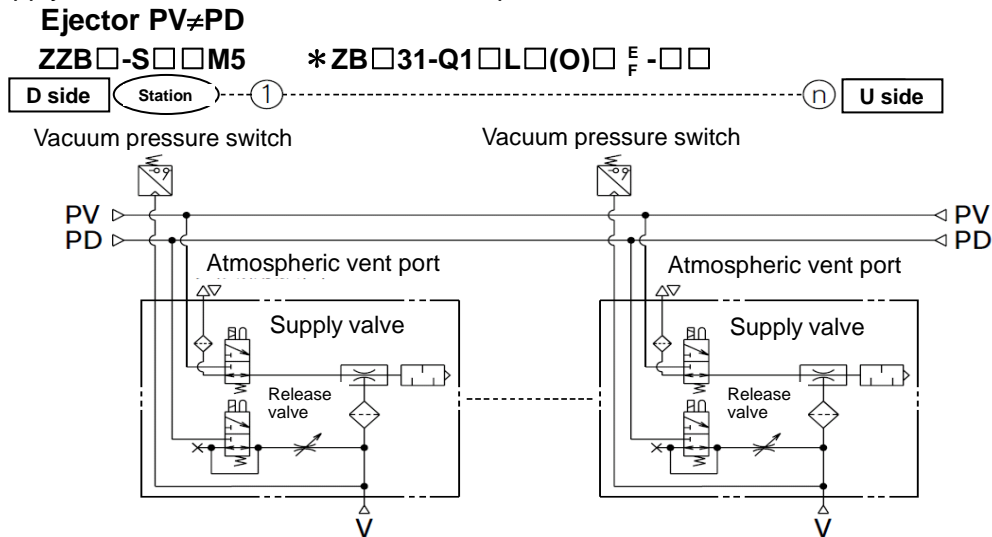

With supply valve /release valve, with vacuum pressure switch

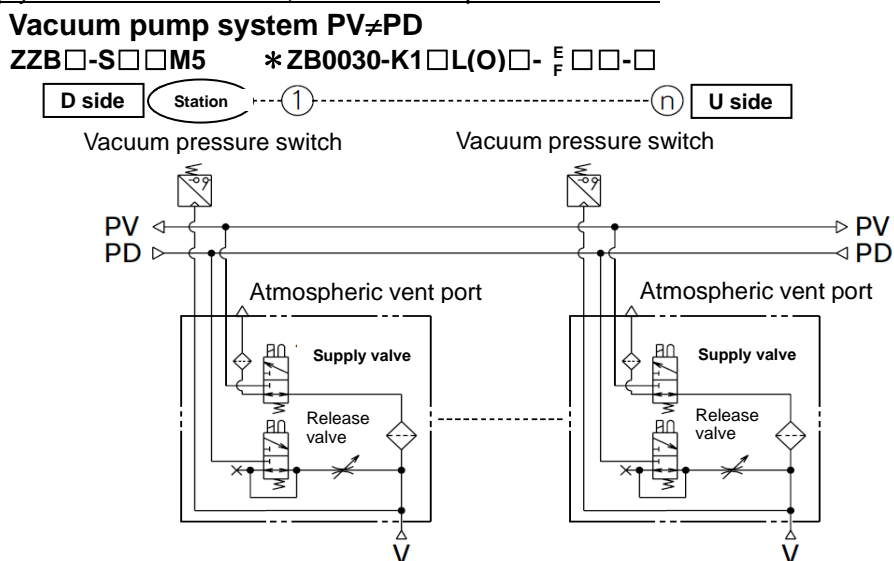

Weight

■ Weight of a Single Unit

Model of a single unit	Weight g
ZB□1/2□-K1□ (Single unit without sensor)	46
ZB□3□-K1□ (One station for manifold without sensor)	40

■ Pressure Sensor, Vacuum pressure switch

Model of pressure sensor and vacuum pressure switch	Weight g
ZB1-PS□-A (Weight excluding the cable)	5
ZB1-ZS□□□-A (Weight excluding the lead wire assembly with connector)	14

■ Manifold Base

Stations	1	2	3	4	5	6	7	8	9	10	11	12
Weight g	16	22	28	34	41	47	53	60	66	72	79	85

- Calculation Formula for Weight of the Manifold Type

(Weight of the single unit x Number of stations) + (Weight of pressure sensor or vacuum pressure switch x Number of stations) + Manifold base

Calculation example:

With pressure sensor, 5-station manifold

$$40\text{g} \times 5\text{pcs.} + 5\text{g} \times 5\text{pcs.} + 41\text{g} = 266\text{g}$$

Exhaust Characteristics and Flow Characteristics of Ejector

■ Nozzle I.D. $\phi 0.3$ Supply Valve: Large Flow Type (N.C.)/ZB03□□-K1/J1

Exhaust characteristics

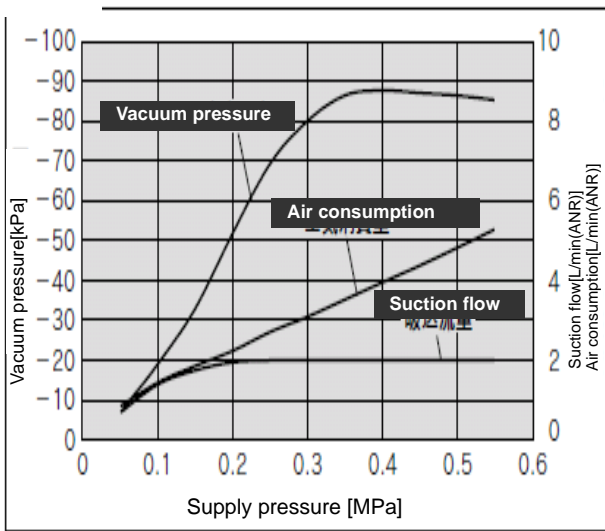

Flow characteristics

(Characteristics when the supply pressure is 0.35 MPa)

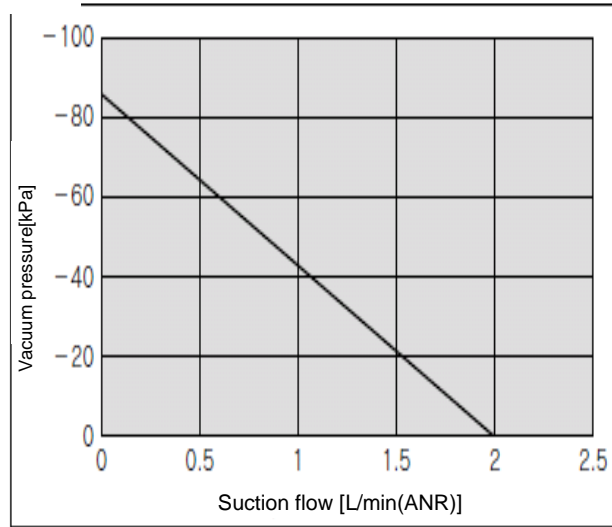

■ Nozzle I.D. $\phi 0.4$ Supply Valve: Large Flow Type (N.C.)/ZB04□□-K1/J1

Exhaust characteristics

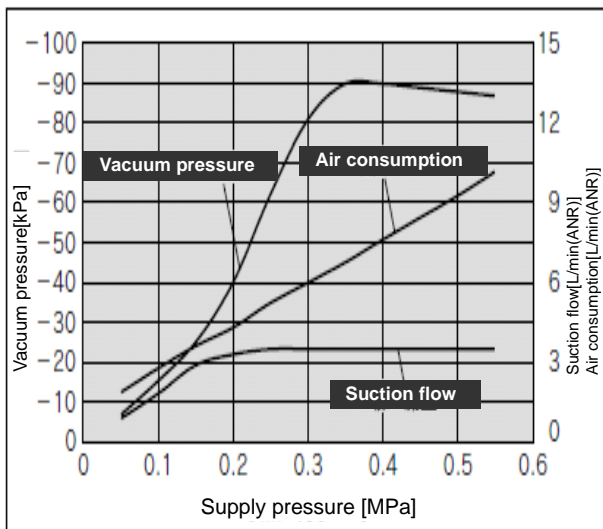

Flow characteristics

(Characteristics when the supply pressure is 0.35 MPa)

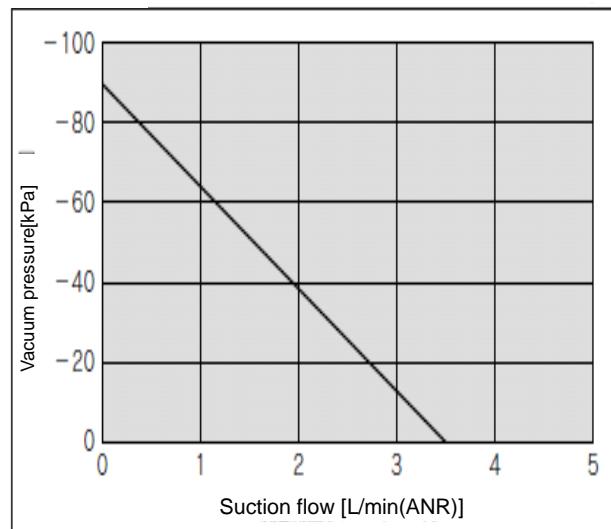

■ Nozzle I.D. $\phi 0.5$ Supply Valve: Large Flow Type (N.C.)/ZB05□□-K1/J1

Exhaust characteristics

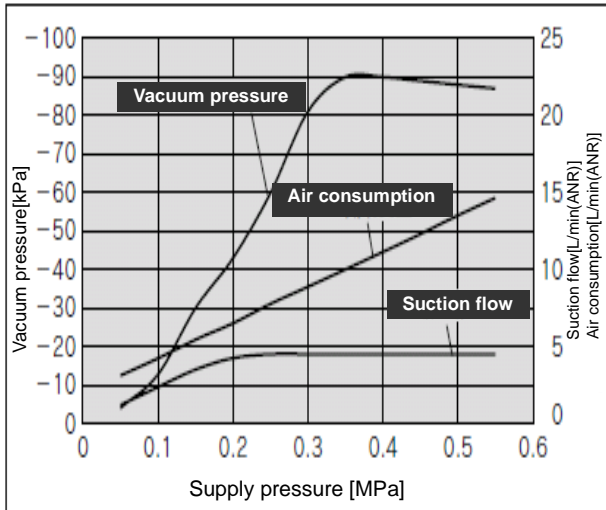

Flow characteristics

(Characteristics when the supply pressure is 0.35 MPa)

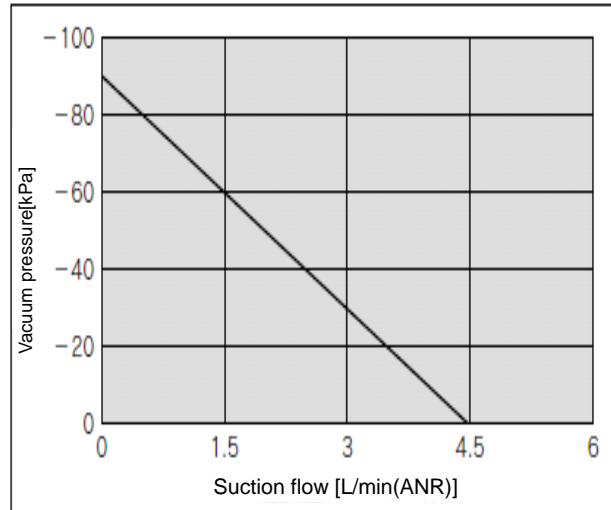

■ Nozzle I.D. $\phi 0.6$ Supply Valve: Large Flow Type (N.C.)/ZB06□□-K1/J1

Exhaust characteristics

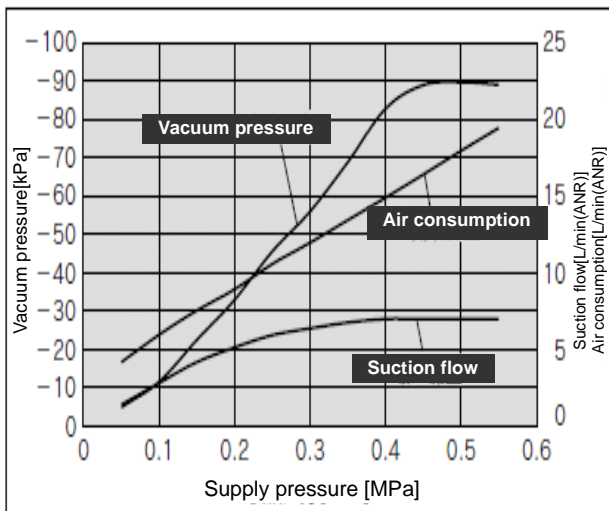

Flow characteristics

(Characteristics when the supply pressure is 0.5 MPa)

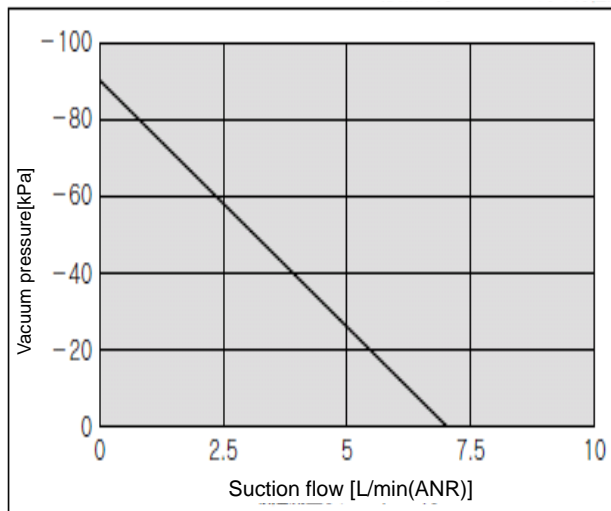

■ Nozzle I.D. $\phi 0.3$ Supply Valve: Latching Type/ZB03□□-Q1/Q2

Exhaust characteristics

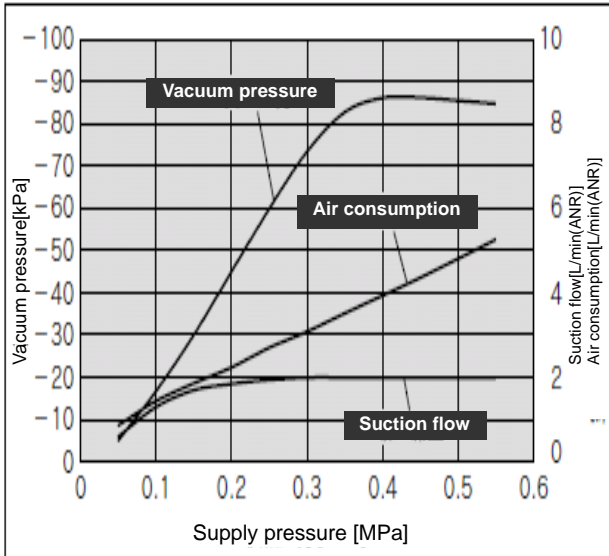

Flow characteristics

(Characteristics when the supply pressure is 0.4 MPa)

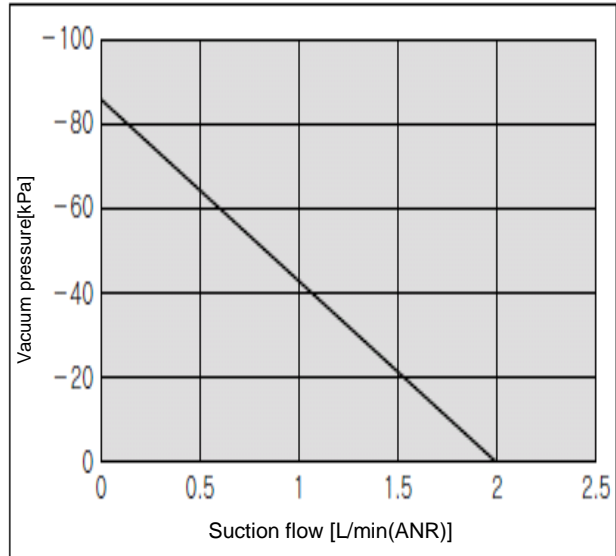

■ Nozzle I.D. $\phi 0.4$ Supply Valve: Latching Type/ZB04□□-Q1/Q2

Exhaust characteristics

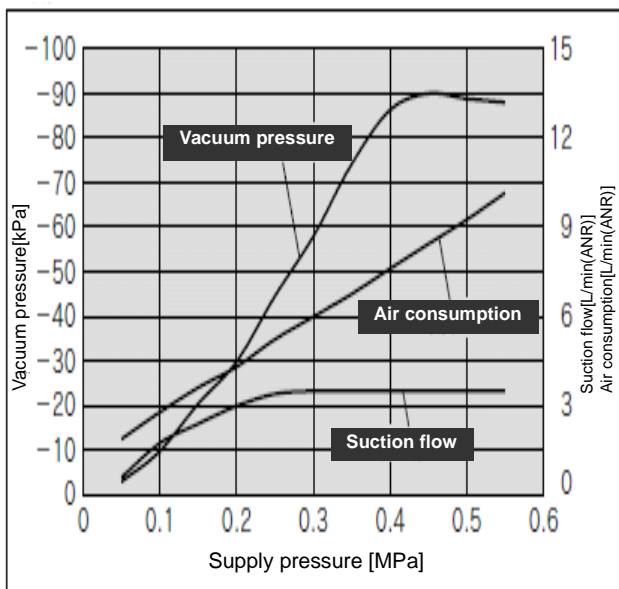

Flow characteristics

(Characteristics when the supply pressure is 0.45 MPa)

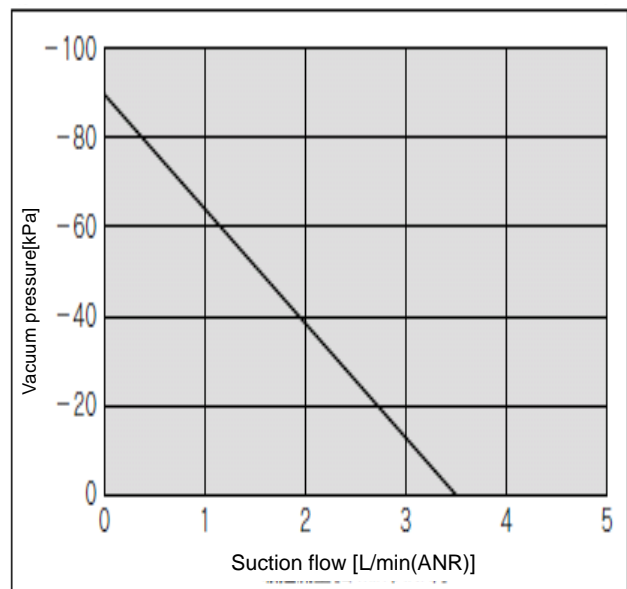

Flow Characteristics of Vacuum Pump System

■ Vacuum Pump System/ZB00□0-K1/J1

The flow rate at the final adsorbing part can vary depending on the piping conditions to the vacuum (V) port. The following graph shows the values when the piping $\phi 4 \times 50 \text{mm}$ is connected to the vacuum (V) port.

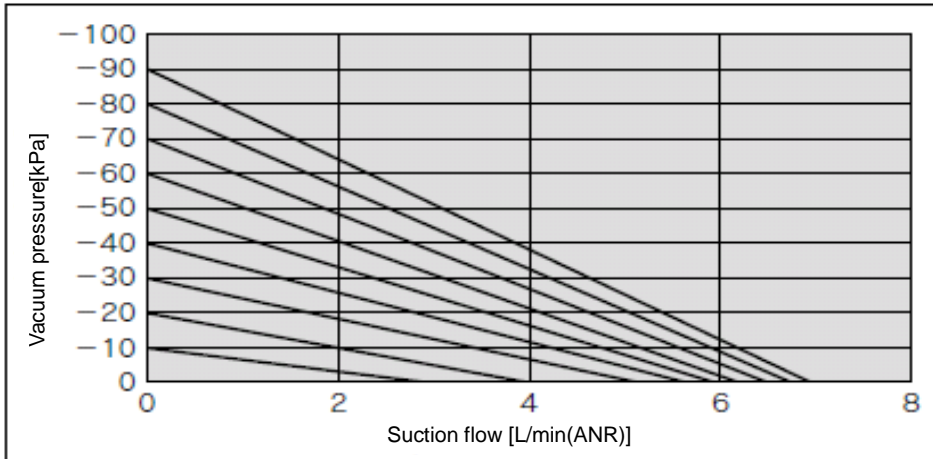

Flow Characteristics Curve

■ How to read the flow characteristics curves of ejector/vacuum pump system

- The flow characteristics curve shows the relationship between the vacuum pressure and the suction flow of the ejector/vacuum pump system. It shows that the vacuum pressure changes when the suction flow changes.

Generally, the curve shows the relationship at the standard supply pressure of the ejector. In the graph on the right, P_{max} means the maximum vacuum pressure and Q_{max} means the maximum suction flow.

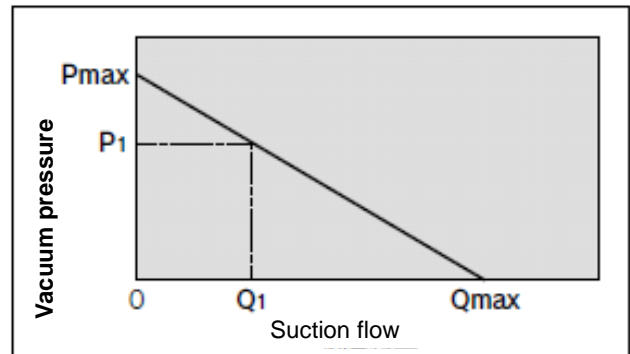

The value shown in this graph is what is shown in this operation manual and the catalogs as the specifications. The change of vacuum pressure is explained in sequence as follows.

- 1) When the vacuum port (V) is closed, the suction flow will be "0" and the vacuum pressure will reach its maximum (P_{max}).
- 2) When the vacuum port (V) is opened gradually, air will flow. (If there is bleeding air, the suction flow will increase, but the vacuum pressure will decrease.): [State of $P_1 - Q_1$]
- 3) If the vacuum port (V) is opened fully, the suction flow will reach its maximum (Q_{max}), but the vacuum pressure will become almost "0" (atmospheric pressure).

As described above, the vacuum pressure changes when the suction flow changes.

Converting this to the adsorption state of the workpiece, the vacuum pressure reaches its maximum when the pad and the piping on the vacuum port (V) have no leakage. Vacuum pressure decreases when there is a lot of leakage when adsorbing a workpiece. When the amount of leakage and the maximum suction flow are equal, the vacuum pressure becomes almost "0", and it fails to adsorb the workpiece.

Vacuum pressure will not increase if the product is used for adsorption of permeable workpieces or in an adsorption state with leakage. In such a case, sufficient verification and prior tests are required.

Pressure Sensor Assembly

■ Pressure Sensor

The pressure sensor mounted to this product is a separate type pressure sensor, and it does not have input and output functions as does a vacuum switch. Use analog output (between 1 and 5V) for your system or use SMC's pressure sensor controller (PSE200, PSE300 series).

■ Handling Precautions

- 1) Do not drop, hit or apply excessive shock (980m/s^2) to the product. The inner parts can be damaged leading to malfunction even if the sensor body is not damaged.
- 2) The tensile strength of the cord is 50N at maximum. Exceeding this value can cause breakdown. Be sure to hold the body when handling.
- 3) Refer to the operation manual of the pressure sensor PSE540 series (on SMC's website URL <https://www.smcworld.com>) for instructions on how to terminate the connectors of this sensor.

Vacuum Pressure Switch Assembly

■ Handling Precautions

- 1) Do not drop, hit or apply excessive shock (100m/s^2) to the product. The inner parts can be damaged leading to malfunction even if the sensor body is not damaged.
- 2) The tensile strength of the lead wire with connector is 35N, and the tensile strength of the lead wire with connector for IO-Link pressure switch is 20N. Exceeding this value can cause breakdown. Be sure to hold the body when handling.
- 3) Avoid repeatedly bending or stretching the lead wire with connector. The lead wire may break if it is wired such that force acts on it. If the lead wire can move, fix it near the body of the product. The recommended bend radius of the lead wire is 6 times the outside diameter of the sheath, or 33 times the outside diameter of the insulation material, whichever is larger.

■ Connection

- 1) Incorrect wiring can damage the switch and cause malfunction. Connections should be done while the power supply is turned off.
- 2) Do not attempt to insert or pull out the connector from the pressure switch while the power is on. This may cause switch output malfunction.
- 3) Malfunctions stemming from noise may occur if the wire is installed in the same route as that of power or high-voltage cable. Wire the ionizer independently.
- 4) Be sure to connect the ground terminal F.G. to ground when using a commercially available switch-mode power supply.
- 5) When wiring to the valves, connecting to supply and release valve properly. Connect the lead wire with wire mark to the supply valve for pressure switch for IO-Link.

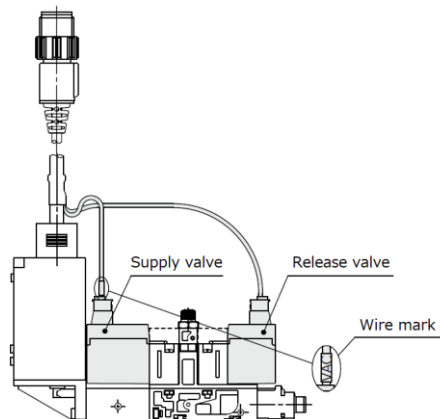

■ Operating Environment

(Common for pressure sensor assembly and vacuum pressure switch assembly)

The use of resin piping can cause static electricity to be generated, depending on the fluid. When connecting the pressure sensor assembly or the vacuum pressure switch assembly, take appropriate measures against static electricity at the customer's equipment side, and separate the grounding for the product from the grounding for any equipment which generates a strong electromagnetic noise or high frequency.

Static electricity can damage the pressure sensor assembly or the vacuum pressure switch assembly.

Refer to SMC's website (URL <https://www.smcworld.com>) for the details of pressure sensor (separate type pressure sensor, PSE series), vacuum pressure switch (compact digital pressure switch, ZISE10 series) and vacuum pressure switch for IO-Link not shown above.

Troubleshooting

■ Problems when using ejector/ vacuum pump system and troubleshooting

Trouble	Cause	Countermeasures
Initial adsorption failure (It fails to adsorb during the trial run.)	The adsorption area is too small; the adsorption force is not strong enough compared with the weight of the work piece and the force applied during transfer.	Increase the lifting force. → Increase the pad diameter → Increase the number of pads.
	Vacuum pressure is too small, due to leakage at the adsorption part or generation of a space between the pad and the work piece due to deformation of the work piece.	Reduce the vacuum leakage (by increasing the vacuum pressure). → Change the pad configuration. Increase the adsorption area. → Change the pad material (e.g. to a material that fits the uneven surface). → If the workpiece is thin, change to a suitable pad.
	Vacuum pressure is too small, due to leakage of vacuum pressure because of permeability of the work piece.	Check the vacuum pressure and the suction flow. → Change to an ejector with larger suction flow.
	Vacuum pressure is too small due to leakage from the vacuum piping.	→ Repair vacuum leaking part.
	Suction flow is too small. (Ejector performance is not high enough.)	→ Change to an ejector with larger suction flow.
	Suction flow is too small because the piping diameter is too small and the length is too long, causing restriction of suction flow from the ejector.	→ Increase the piping diameter and decrease length on the vacuum side.
	Vacuum pressure and/or suction flow are too small, because supply pressure to the ejector is insufficient.	→ Measure the supply pressure when the vacuum is generated, and increase the supply pressure to the standard supply pressure. Especially when more than one product is operated at the same time in a manifold, the supply air can be insufficient, causing decrease of the supply pressure.
	Vacuum pressure and/or suction flow are too small, due to clogging of the nozzle and the diffuser.	→ Remove foreign matter and substances sticking to it. (Needs to be repaired.) Perform flushing and mount an air filter on the supply side to prevent it happening again.
	Supply valve malfunction.	Measure the supply voltage to the solenoid valve. → Revise the electrical circuit, wiring and connectors. → Use within the rated voltage range.

Trouble	Cause	Countermeasures
Adsorption response is not quick enough.	Internal capacity of the circuit on the vacuum side is too large for the ejector performance.	→ Reduce the internal capacity of the vacuum circuit. → Change to an ejector with larger suction flow.
	The set vacuum pressure for the suction verification is too high, making the time before it reaches the set value longer.	Optimize the lifting force and change the setting to have the suction verification of vacuum pressure as low as possible.
Fluctuation of vacuum pressure	Supply pressure fluctuates.	Install a tank in the compressed air line on the supply side, and reduce the air consumption of other equipment.
	The generated vacuum pressure fluctuates, making the exhaust noise intermittent at a certain supply pressure range.	This is a phenomenon peculiar to ejectors which is caused when the supply pressure is a little lower than the standard supply pressure. → Increase or decrease the supply pressure a small amount.
Vacuum failure over time (absorbs properly initially.)	Vacuum pressure is reduced, due to clogging of the suction filter (caused by dust in the environment on the vacuum side, sucking of foreign matter from surface of work piece, adsorption of humidity, etc.)	→ Replace the filter element with a new one. → Increase the number of suction filters (such as ZFA, ZFB and ZFC)
	Vacuum pressure is reduced, because of the clogging of the silencer (due to foreign matter such as drainage and carbon particles in the supply air).	Clean the supply air. → Control the drainage. → Add an air filter and a mist separator. → Replace the silencer with a new one.
	Vacuum pressure and/or suction flow is reduced due to clogging of the nozzle and the diffuser.	→ Remove foreign matter and substances sticking to it. (Needs to be repaired.) Mount an air filter on the supply side to prevent it from happening again.
	Vacuum pressure and/or suction flow is reduced due to clogging of the nozzle and the diffuser.	→ Remove foreign matter and substances sticking to it. (Needs to be repaired.) Mount an air filter on the supply side to prevent it happening again.

Trouble	Cause	Countermeasures
Vacuum failure over time (absorbs properly initially.)	Adsorbing part has some problem, such as deterioration of the vacuum pad, or leakage due to frictional wear.	→ Replace the vacuum pad with a new one. → Revise the adsorption conditions (such as compatibility of the vacuum pressure with the pad/work piece)
	The filter case gasket has come off when the filter element was replaced.	Vacuum pressure leaks if the gasket has come off or out of the groove when maintenance of the filter was performed . → Check if it is mounted properly.
	Defective operation caused by energization of solenoid valve for an extended period of time. (Energized for 10 minutes or more or operated with the duty ratio of 50% or more.)	→ Shorten the energization time of the solenoid valve. → Provide forced ventilation in the operating environment in order to prevent temperature increase around the solenoid valve.
Work piece is not released smoothly.	Vacuum release flow is not large enough.	→Open the vacuum release flow adjustment needle. → For the ejector with individual ports for release pressure (PD) and supply pressure (PV), increase the pressure at the release pressure port.
	The vacuum pad surface is worn out, making it sticky.	→ Replace the vacuum pad with a new one. → Revise the material and configuration of the vacuum pad. → Use a special pad which has a blasted adsorption surface. (Made-to-order)
	Vacuum pressure is too high.	→ Decrease the supply pressure to lower the vacuum pressure. → Decrease the pressure in the piping on the vacuum side with a vacuum regulator.
	Work piece sticks to the pad due to static electricity.	→ Use a conductive pad.
	Vacuum release signal timing is inappropriate.	If the pad is lifted before the work piece is completely released from the pad, the workpiece is lifted together with the pad due to the viscosity of the pad. → Revise the timing of the vacuum release and the lifting of the pad.

If the countermeasures above are not effective, there may be some problem with the product. In that case, stop using the product immediately **without disassembling or repairing it.**

If any of the examples below are applicable, there may be a problem with the product.

1) It was used with a voltage other than the rated voltage. 2) Lubricant was contained in the supply air. 3) Liquid such as water was directly splashed onto the product body. 4) A strong impact was applied to the product. 5) Drainage and dust got mixed into the supply air. 6) Other actions corresponding to the precautions mentioned in this operation manual have occurred.

When removing the product from the application, be sure to confirm that the safety measures are taken, and shut off the compressed air supply and the power supply before removing the product.

Revision history

A :	
P.19	Recommended tube fittings
P.21	Piping to the Manifold Base
B :	
P.21	Change of description about tightening of fitting.
P.38	Change of description about filter element.
C : Compliant with UKCA standard	
D :	
P7,10,12,36,44,45,54	Added of IO-Link pressure switch
P29	Change of energization time of latching type supply valve
P30,32,36,39	Added of replacement parts
P40	Change of Vacuum release flow characteristics
P1,13,16,38,40,57	Change of vacuum release expression
P1,16,40,57	Change of adjustment needle expression
E :	
P2,3	Change of Safety Instructions
P29	Change of How to operate the supply valve of the latching type
P54	Change of Handling Precautions

SMC Corporation

Tel: + 81 3 5207 8249 Fax: +81 3 5298 5362

URL <https://www.smcworld.com>

Note: Specifications are subject to change without prior notice and any obligation on the part of the manufacturer.

© SMC Corporation All Rights Reserved