



# Operation Manual

PRODUCT NAME

*Compact Cylinder with Linear Guide*

MODEL / Series / Product Number

MXZ12(R,L)-\*\*

MXZ16(R,L)-\*\*

MXZ20(R,L)-\*\*

MXZ25(R,L)-\*\*

**SMC Corporation**

# Contents

## Safety Instructions

### 1. Product Specifications

#### 1-1 Specifications

### 2. Installation

#### 2-1 Mounting

#### 2-2 Air supply

#### 2-3 Piping

#### 2-4 Operating environment

#### 2-5 Lubricating

#### 2-6 Speed adjustment

#### 2-7 Auto switch mounting

### 3. Maintenance

#### 3-1 Precautions for maintenance

#### 3-2 Replenishment of grease

#### 3-3 Removing the product

#### 3-4 Construction and parts



# Safety Instructions

These safety instructions are intended to prevent hazardous situations and/or equipment damage. These instructions indicate the level of potential hazard with the labels of “Caution,” “Warning” or “Danger.”

They are all important notes for safety and must be followed in addition to International Standards (ISO/IEC)\*1), and other safety regulations.

\*1) ISO 4414: Pneumatic fluid power -- General rules relating to systems.

ISO 4413: Hydraulic fluid power -- General rules relating to systems.

IEC 60204-1: Safety of machinery -- Electrical equipment of machines .(Part 1: General requirements)

ISO 10218: Manipulating industrial robots -Safety.

etc.



## Caution

**Caution** indicates a hazard with a low level of risk which, if not avoided, could result in minor or moderate injury.



## Warning

**Warning** indicates a hazard with a medium level of risk which, if not avoided, could result in death or serious injury.



## Danger

**Danger** indicates a hazard with a high level of risk which, if not avoided, will result in death or serious injury.

## Warning

### **1. The compatibility of the product is the responsibility of the person who designs the equipment or decides its specifications.**

Since the product specified here is used under various operating conditions, its compatibility with specific equipment must be decided by the person who designs the equipment or decides its specifications based on necessary analysis and test results.

The expected performance and safety assurance of the equipment will be the responsibility of the person who has determined its compatibility with the product.

This person should also continuously review all specifications of the product referring to its latest catalog information, with a view to giving due consideration to any possibility of equipment failure when configuring the equipment.

### **2. Only personnel with appropriate training should operate machinery and equipment.**

The product specified here may become unsafe if handled incorrectly.

The assembly, operation and maintenance of machines or equipment including our products must be performed by an operator who is appropriately trained and experienced.

### **3. Do not service or attempt to remove product and machinery/equipment until safety is confirmed.**

1. The inspection and maintenance of machinery/equipment should only be performed after measures to prevent falling or runaway of the driven objects have been confirmed.

2. When the product is to be removed, confirm that the safety measures as mentioned above are implemented and the power from any appropriate source is cut, and read and understand the specific product precautions of all relevant products carefully.

3. Before machinery/equipment is restarted, take measures to prevent unexpected operation and malfunction.

### **4. Contact SMC beforehand and take special consideration of safety measures if the product is to be used in any of the following conditions.**

1. Conditions and environments outside of the given specifications, or use outdoors or in a place exposed to direct sunlight.

2. Installation on equipment in conjunction with atomic energy, railways, air navigation, space, shipping, vehicles, military, medical treatment, combustion and recreation, or equipment in contact with food and beverages, emergency stop circuits, clutch and brake circuits in press applications, safety equipment or other applications unsuitable for the standard specifications described in the product catalog.

3. An application which could have negative effects on people, property, or animals requiring special safety analysis.

4. Use in an interlock circuit, which requires the provision of double interlock for possible failure by using a mechanical protective function, and periodical checks to confirm proper operation.



# Safety Instructions

## Caution

### **The product is provided for use in manufacturing industries.**

The product herein described is basically provided for peaceful use in manufacturing industries.

If considering using the product in other industries, consult SMC beforehand and exchange specifications or a contract if necessary.

If anything is unclear, contact your nearest sales branch.

## **Limited warranty and Disclaimer/Compliance Requirements**

The product used is subject to the following “Limited warranty and Disclaimer” and “Compliance Requirements”.

Read and accept them before using the product.

### **Limited warranty and Disclaimer**

1. The warranty period of the product is 1 year in service or 1.5 years after the product is delivered, whichever is first. \*2)

Also, the product may have specified durability, running distance or replacement parts. Please consult your nearest sales branch.

2. For any failure or damage reported within the warranty period which is clearly our responsibility, a replacement product or necessary parts will be provided.

This limited warranty applies only to our product independently, and not to any other damage incurred due to the failure of the product.

3. Prior to using SMC products, please read and understand the warranty terms and disclaimers noted in the specified catalog for the particular products.

\*2) Vacuum pads are excluded from this 1 year warranty.

A vacuum pad is a consumable part, so it is warranted for a year after it is delivered.

Also, even within the warranty period, the wear of a product due to the use of the vacuum pad or failure due to the deterioration of rubber material are not covered by the limited warranty.

### **Compliance Requirements**

1. The use of SMC products with production equipment for the manufacture of weapons of mass destruction (WMD) or any other weapon is strictly prohibited.

2. The exports of SMC products or technology from one country to another are governed by the relevant security laws and regulation of the countries involved in the transaction. Prior to the shipment of a SMC product to another country, assure that all local rules governing that export are known and followed.

## Caution

### **SMC products are not intended for use as instruments for legal metrology.**

Measurement instruments that SMC manufactures or sells have not been qualified by type approval tests relevant to the metrology (measurement) laws of each country.

Therefore, SMC products cannot be used for business or certification ordained by the metrology (measurement) laws of each country.

# 1. Product Specifications

## 1-1 Specifications

Model	MXZ12	MXZ16	MXZ20	MXZ25
Bore size(mm)	Φ12	Φ16	Φ20	Φ25
Pilot port	M3x0.5		M5x0.8	
Fluid	Air			
Action	Double acting			
Operating pressure	0.1 to 0.7 MPa			
Proof pressure	1.05MPa			
Ambient and fluid temperature	5 to 60°C			
Piston speed (Average speed)	50 to 500mm/s			
(Reference) maximum piston collision speed	700mm/s			
Cushion	Rubber bumper			
Auto switch	Solid state auto switch (2-wire, 3wire) 2-color indicator solid state auto switch(2-wire, 3wire)			
Stroke length tolerance 1)	+1.3 to 0 mm(when pressure is not applied)			

1) Stroke length tolerance does not include the amount of bumper change.

## 2. Installation

### 2-1 Mounting

(1) Mounting of body

Two types of installation are available according to the machine or work piece.

1. Tap mounting

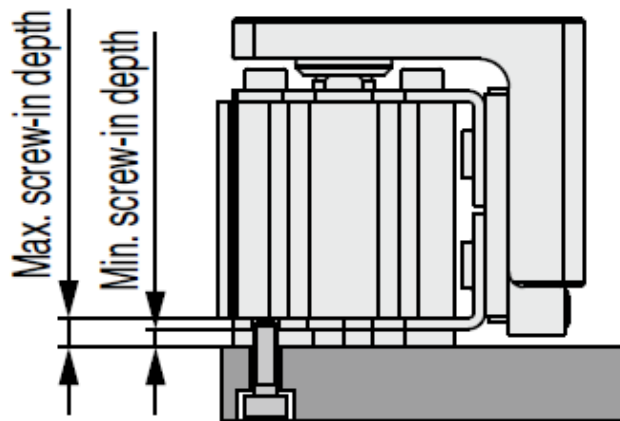

Model	Bolt	Tightening torque (N · m)	Min. screw-in depth (mm)	Max. screw-in depth [mm]
MXZ12	M3x0.5	0.63	2.5	3.4
MXZ16	M3x0.5			3.4
MXZ20	M3x0.5			3.7
MXZ25	M3x0.5			4.1

**!** If bolts are too long, they will come into contact with the cylinder tube, in this case, the product will not be held correctly. Use bolts that are between the maximum and minimum screw-in depths in length.

## 2. Through-hole Mounting

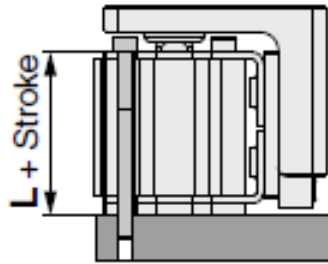

Model	Bolt	Tightening torque (N · m)	L(mm)
MXZ12	M3x0.5	0.63	24.5
MXZ16	M3x0.5		25.5
MXZ20	M3x0.5		29.7
MXZ25	M3x0.5		32.2

(2) How to mount the workpiece  
Mounting to the Table Using the Tapped Holes

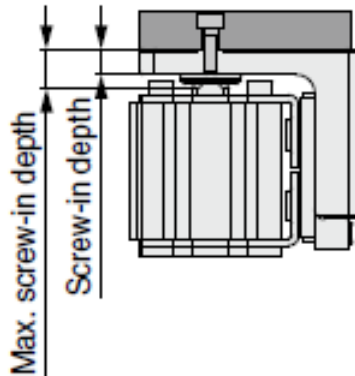

Model	Bolt	Tightening torque (N · m)	Min. screw-in depth (mm)	Max. screw-in depth [mm]
MXZ12	M3x0.5	0.63	5	6
MXZ16	M3x0.5		5	6
MXZ20	M3x0.5		5.5	6.3
MXZ25	M3x0.5		6.5	8.3



### Caution

- 1) If bolts are too long, they will come into contact with the bracket or flange during retraction, this will lead to the guide malfunction. Do not use bolts that are over the maximum screw-in depth in length.
- 2) When tightening the screws into the table surface, be careful to prevent applying a torque to the guide.

### (3) Precautions for mounting



#### Caution

- 1) Do not dent, scratch or cause other damage to the body, table and end plate mounting surfaces. This may cause unevenness in the mounting surface, play in the guide or an increase in the sliding resistance.
- 2) Do not dent, scratch or cause other damage to the surface over which the rail and guide will move. This may cause play or an increase in the sliding resistance.

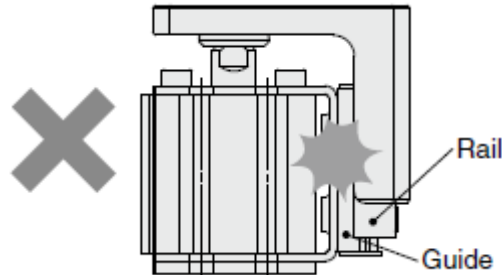

- 3) Do not apply strong impact or an excessive moment while mounting a workpiece. If an external force over the allowable moment is applied, it may cause play in the guide or an increase in the sliding resistance.
- 4) Select the proper connection with the load which has external support and/or guide mechanism on the outside, and align it properly.
- 5) Do not attach magnets to the rail and guide unit. Since the rail and guide are made of a magnetic substance, it could become magnetized if touched by a magnet etc. This could cause auto switch malfunction.

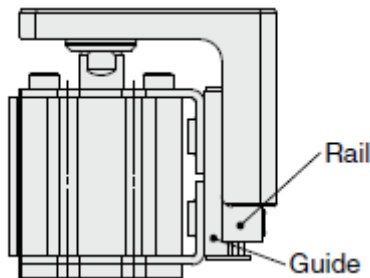

- 6) When mounting the product and a jig, tighten it with screws of appropriate length at an appropriate torque. Tightening with a torque above the specified torque can cause malfunction, while insufficient tightening can cause slippage and dropping.

### (4) Precautions

#### 1. For Transfer



#### Caution

If the operating speed is increased after setting the operating conditions such as overhang and operating speed, the stopping impact force will increase which causes an excessive moment to be generated; this will lead to the failure of the guide. Do not increase the operating speed after setting the operating conditions.

If the adjusting screw of the speed controller is loosened, the operating speed will increase, so the screw should be tightened completely.

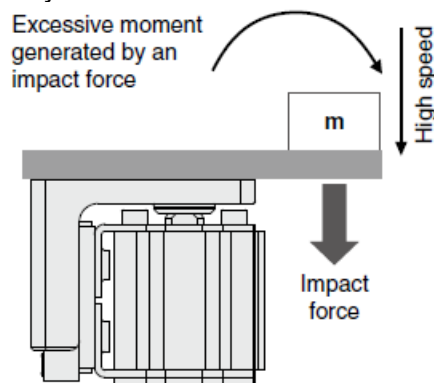

## 2. For Pressing (Clamping)



Caution

Pressing work should be performed in line with the center of the guide.

If there is an offset in the L2 direction, an eccentric load will be applied to the guide. In this case, pressing operations should not be performed.

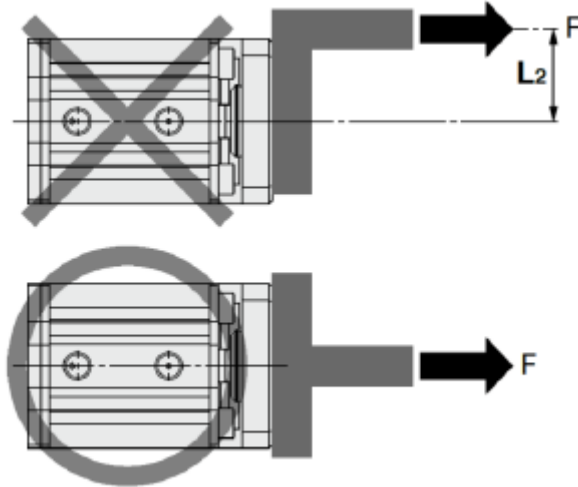

## 3. For Stopper



Caution

1) If a load is applied in the direction as shown on the right side, an eccentric load will be applied to the guide. In this case, the product should not be used as a stopper.

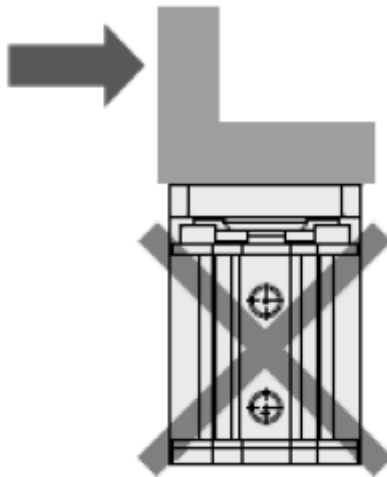

2) The transferred object should be stopped in line with the center of the guide.

If there is an offset in the L2 direction, an eccentric load will be applied to the guide. In this case, this product should not be used as a stopper.

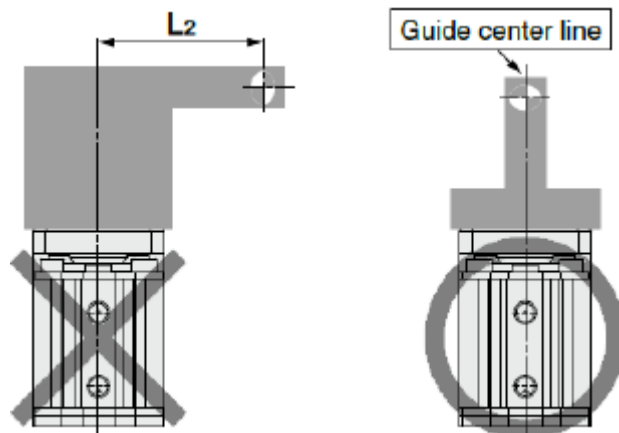



3) Place a bracket so that it contacts the machined corner of the surface for mounting or insert a pin into the through hole on the side to prevent sliding.

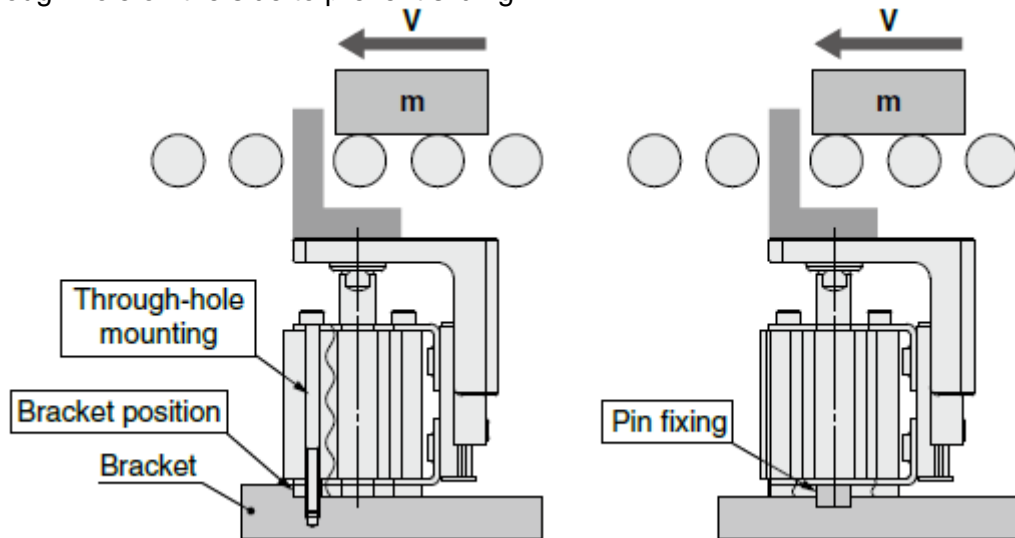

(5) Others Caution



Warning

1) Do not place your hands or fingers between the table and the bracket.

Hands or fingers could get caught between the table and the bracket when the piston rod retracts. If hands or fingers are caught, it can lead to injury.

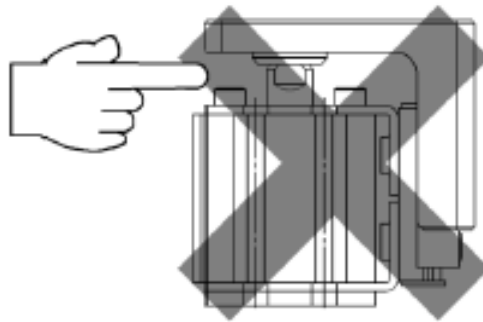

Caution

1) Do not disassemble and modify the product.

2) If the cylinder is stopped at an intermediate position by external stopper, position of the steel balls that make up the liner guide may become displaced.

When the intermediate stop is released while the steel ball position is displaced, the cylinder may not be able to achieve a full stroke with minimum operating pressure.

In this case, increase the supply pressure once up to the full stroke, then use the cylinder with the specified pressure.

## 2-2 Air supply



Warning

1) Use clean air.

Do not use compressed air which contains chemicals, synthetic oils containing organic solvents, salts or corrosive gases, etc., as this can cause damage or malfunction.



Caution

1) Install an air filter.

Install an air filter close to the upstream side of the valve. Choose the filter of 5 $\mu$ m of filtration.

2) Install an aftercooler, air dryer or water droplet separator.

Do not use compressed air containing a lot of condensate, which can cause the operating failure of the product and other pneumatic equipment. Install an aftercooler, air dryer or water droplet separator.

3) Use the product within the specified fluid and ambient temperature range.

When operating at temperatures below 5 $^{\circ}$ C, water in the circuit may freeze and cause breakage of seals or malfunction. Corrective measures should be taken to prevent freezing.

For compressed air quality, refer to SMC catalog "Compressed Air Purification System".

## 2-3 Piping



Caution

1) Before piping

Before piping, perform air blow (flushing) or cleaning to remove any cutting chips, cutting oil, dust, etc. from the piping.



2) Sealant tape

When installing piping or a fitting into a port, prevent cutting chips and sealant material from getting inside the piping.

When a pipe tape is used, leave 1.5 to 2 thread ridges exposed at the end of the pipe.

## 2-4 Operating environment



Warning

- 1) Do not use in environments where there is a danger of corrosion. Refer to the construction drawings regarding cylinder materials.
- 2) Install a cover over the rod if it is used in an area that is dusty, or in an environment in which water or oil splashes on the cylinder.
- 3) When using auto switches, do not operate in an environment with strong magnetic fields. As this can cause the switch to malfunction.



Caution

- 1) Do not use in an environment where the product is directly exposed to liquid, such as cutting oils. If cutting oil, coolant or oil mist splashes the product, play, increased sliding resistance and air leakage can result.
- 2) Do not use the product in an environment directly exposed to foreign matter such as dust, cutting chips and spatter. This can result in play, increased operating resistance, air leakage, etc. If the product is used in such an environment, contact SMC.
- 3) Shade the sunlight if the product is applied with direct sunshine.
- 4) Shield the product from radiated heat generated by nearby heat sources. When there is a heat source surrounding the product, the radiated heat from the heat source may exceed the operating temperature range. Protect it with a cover, etc.
- 5) Do not operate in a location subject to vibration or impact. Contact SMC when using in this kind of location, as damage and operation failure to the fitting can result.
- 6) Do not use the product in applications where excessive external force or impact force is applied to it. Malfunction or the damage of the table can result. Although the table has adequate strength, if it is damaged, protect your hands with gloves. Hurts can result.

## 2-5 Lubricating



Caution

Lubrication of non-lubricating cylinder

The product has been lubricated for life at manufacturer, and does not require lubrication in service. If a lubricant is used in the system, use turbine oil Class 1 (with no additive) ISO VG302. Stopping lubrication later may lead to malfunction because the new lubricant will displace the original lubricant. Therefore, lubrication must be continued once it has been started.

## 2-6 Speed adjustment



Caution

Piston speed should be controlled gradually from low speed to the specified speed with a speed controller.

## 2-7 Auto Switch Mounting

Precautions for mounting



Caution

1) Auto switch mounting tool

For the tightening of the mounting screws (attached to the auto switch), use a watchmaker's screwdriver with a handle diameter of about 5 to 6 mm.

2) Tightening torque

0.05 to 0.15N·m

As a guide, turn an additional 90 degrees from the position where it feels tight.

### ■Tightening Torque

Tightening Torque for Auto Switch Mounting Screw (N·m)

Auto switch model	Tightening torque
D-M9□(V)/M9□W(V)	0.05 to 0.15

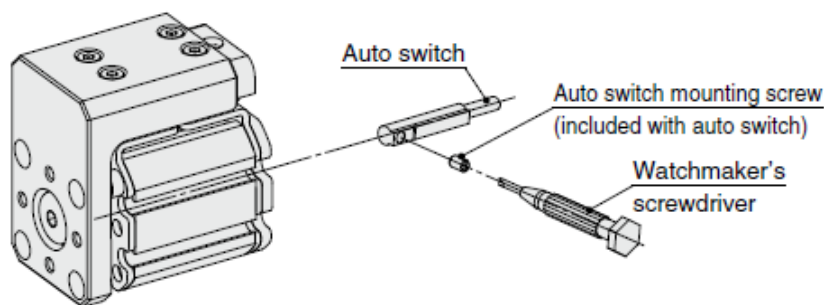

3) Please refer the table below for proper mounting position of the auto switch (when the stroke end is detected).

For the setting of the auto switch, make adjustment checking the actual operating condition.

### Minimum Stroke for Auto Switch Mounting

Auto switch model	D-M9□V	D-M9□WV D-M9□AV	D-M9□	D-M9□W D-M9□A
	Mourning			
(1) Bottom mounting	5	10 *2)	15 *1)	15 *1)
(2) When mounting an auto switch into the groove from the top*3)	15	15	30	30
(3)When mounting the autoswitch into the groove through the mounting surface.	5	10 *2)	5	10 *2)

\*1) For 5 and 10 mm strokes, lead wires will interfere with mounting surface.

\*2) For 5 mm stroke, it is possible to mount an auto switch, but 2-color display may not be available.

\*3 )When mounting an auto switch from the top with 5 or 10 mm strokes, use a D-F8 auto switch.

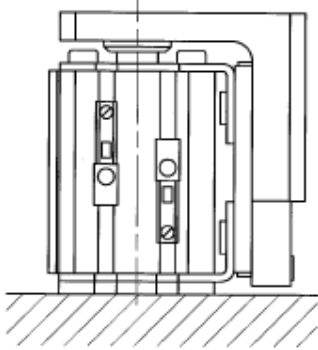

(1) Bottom mounting  
(When mounting an auto switch before holding the product)

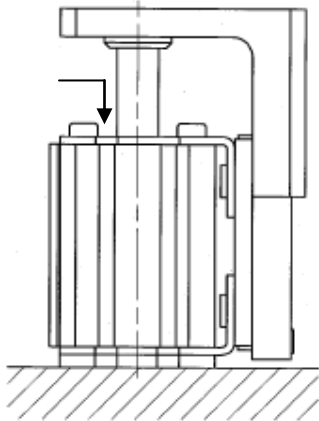

(2) When mounting an auto switch into the groove from the top  
(When mounting an auto switch into the groove from the top after installation)

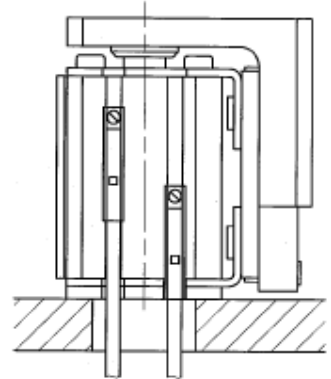

(3) When mounting the autoswitch into the groove through the mounting surface.

### Auto Switch Proper Mounting Position

Auto switch model Bore size	D-M9□, D-M9□W			D-M9□V, D-M9□WV			D-M9□A			D-M9□AV		
	A	B	W	A	B	W	A	B	W	A	B	W
12	6.2	6.2	3.8	6.2	6.2	1.8	6.2	6.2	5.8	6.2	6.2	3.8
16	6.7	6.7	3.3	6.7	6.7	1.3	6.7	6.7	5.3	6.7	6.7	3.3
20	7.5	10	—	7.5	10	—	7.5	10	2	7.5	10	—
25	8	12	—	8	12	—	8	12	—	8	12	—

### Auto Switch Mounting Height

Auto switch model Bore size	D-M9□V, D-M9□WV, D-M9□AV	
	U	
12	19.5	
16	21	
20	23	
25	24.5	

### Operating Range

Auto switch model	Applicable bore size			
	12	16	20	25
D-M9□(V)/M9□W(V)/M9□A(V)	3	3	4.5	4.5

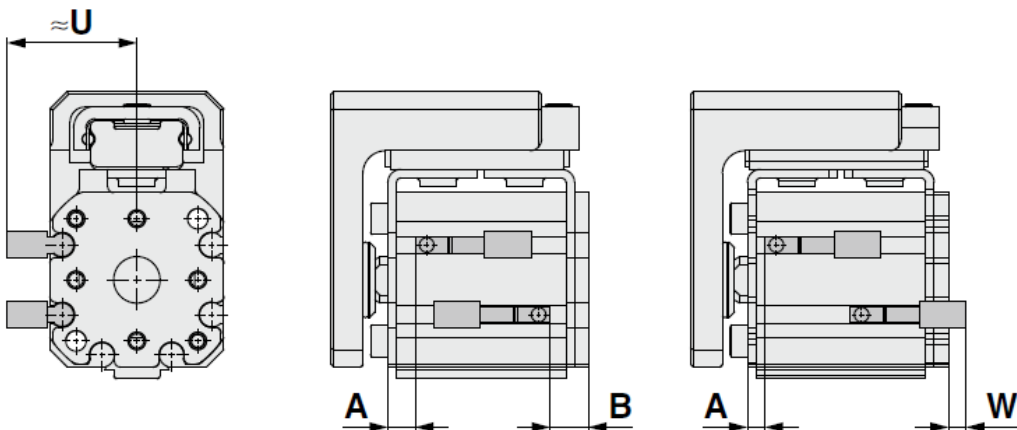

# Basic Wiring

## Solid state 3-wire, NPN

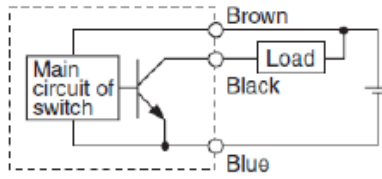

## Solid state 3-wire, PNP

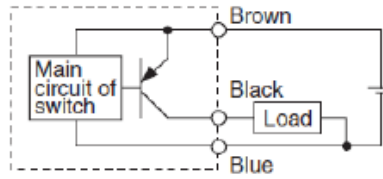

## 2-wire (Solid state)

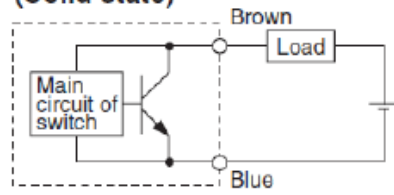

(Power supply for switch and load are separate.)

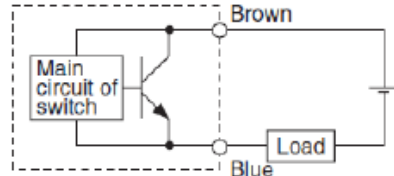
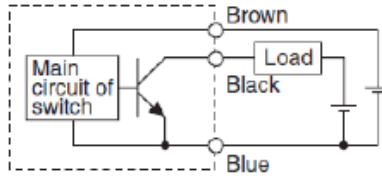

## Sink Input Specifications

### 3-wire, NPN

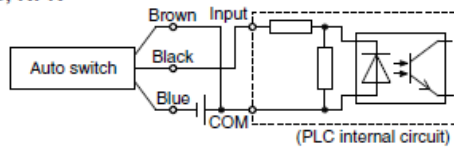

## Source Input Specifications

### 3-wire, PNP

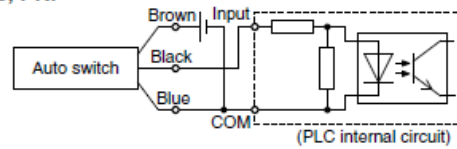

### 2-wire

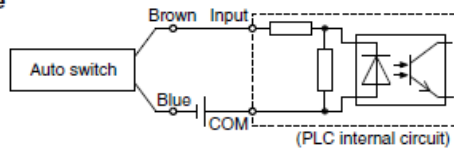

### 2-wire

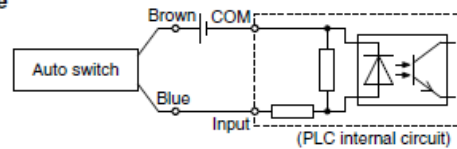

Connect according to the applicable PLC input specifications, as the connection method will vary depending on the PLC input specifications.

# Examples of AND (Series) and OR (Parallel) Connections

\* When using solid state auto switches, ensure the application is set up so the signals for the first 50 ms are invalid. Depending on the operating environment, the product may not operate properly.

## 3-wire AND connection for NPN output

(Using relays)

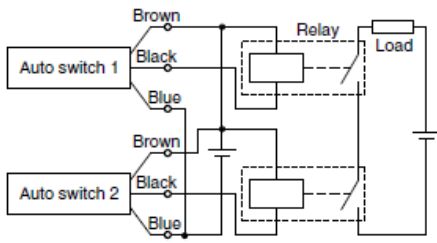

(Performed with auto switches only)

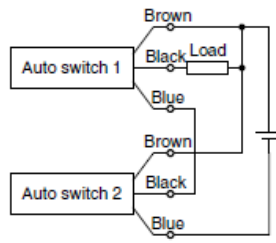

## 3-wire OR connection for NPN output

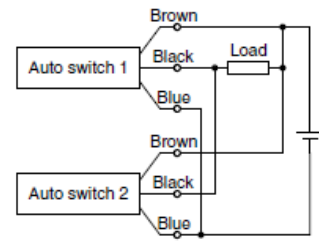

## 3-wire AND connection for PNP output

(Using relays)

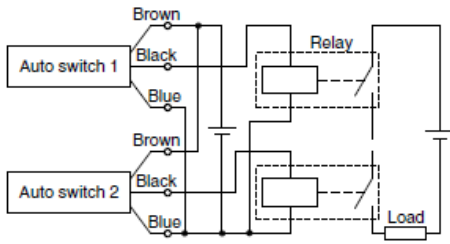

(Performed with auto switches only)

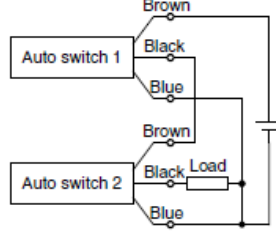

## 3-wire OR connection for PNP output

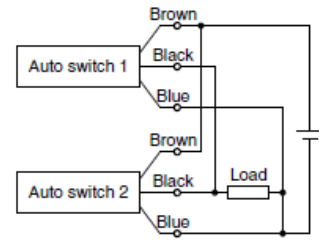

## 2-wire AND connection

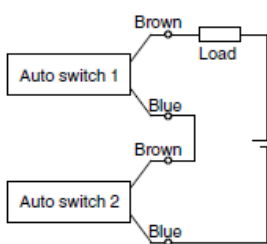

When two auto switches are connected in series, a load may malfunction because the load voltage will decline when in the ON state. The indicator lights will light up when both of the auto switches are in the ON state. Auto switches with a load voltage less than 20 V cannot be used.

$$\begin{aligned} \text{Load voltage at ON} &= \text{Power supply voltage} - \\ &\quad \text{Residual voltage} \times 2 \text{ pcs.} \\ &= 24 \text{ V} - 4 \text{ V} \times 2 \text{ pcs.} \\ &= 16 \text{ V} \end{aligned}$$

Example: Power supply is 24 VDC  
Internal voltage drop in auto switch is 4 V.

## 2-wire OR connection

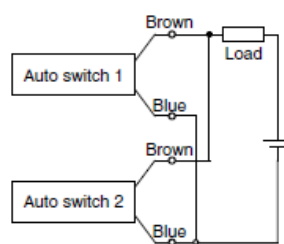

(Solid state)  
When two auto switches are connected in parallel, malfunction may occur because the load voltage will increase when in the OFF state.

$$\begin{aligned} \text{Load voltage at OFF} &= \text{Leakage current} \times 2 \text{ pcs.} \times \\ &\quad \text{Load impedance} \\ &= 1 \text{ mA} \times 2 \text{ pcs.} \times 3 \text{ k}\Omega \\ &= 6 \text{ V} \end{aligned}$$

Example: Load impedance is 3 kΩ.  
Leakage current from auto switch is 1 mA.

### 3. Maintenance

#### 3-1 Precautions for maintenance

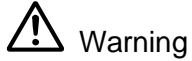

Warning

1) Maintenance should be performed according to the procedure indicated in the Operation Manual. Improper handling can cause damage and malfunction of equipment and machinery.

2) Removal of equipment, and supply/exhaust of compressed air

When components are removed, first confirm that measures are in place to prevent workpieces from dropping and/or equipment running away, etc. Cut the supply pressure and electric power and exhaust all compressed air from the system. Before restarting the equipment, confirm that measures are taken to prevent sudden movement.

#### 3-2 Replenishment of grease



Caution

1) Applying additional grease on the guide

This product has been lubricated for life by the manufacturer, and it is not necessary to apply further grease. If grease is replenished, use grease pack.

Grease pack

Grease application part	Grease pack No.	Mass
Guide	GR-S-010	10g
	GR-S-020	20g

#### 3-3 Removing the product



Caution

Do not remove the bolts holding the linear guide when removing the product. Incorrect handling of the product may cause mounting accuracy failure.

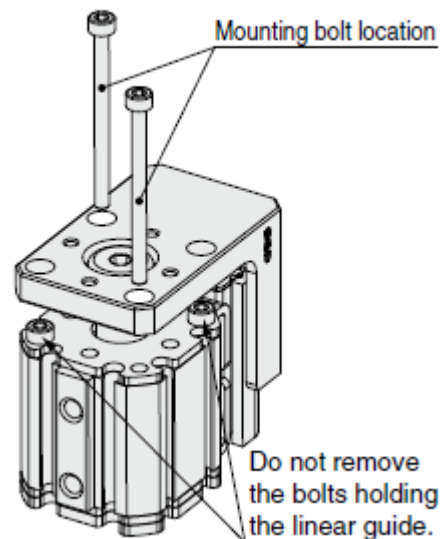
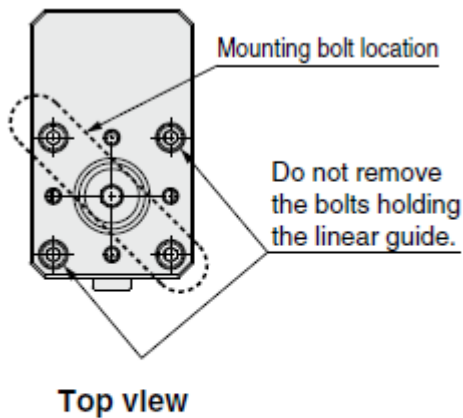



### 3-3 Construction and parts

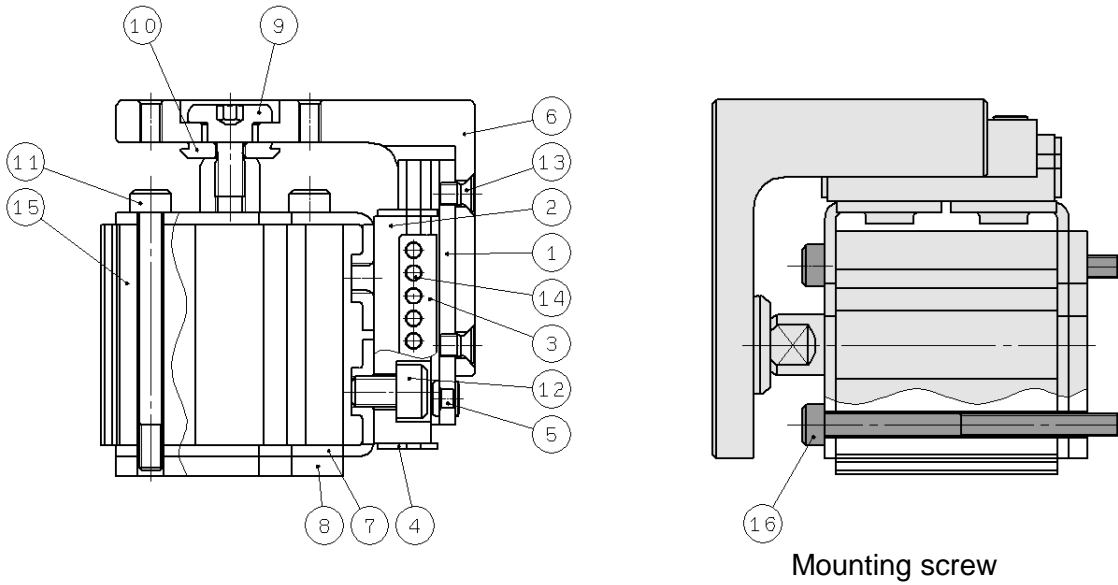

Basic type/Component parts

No.	Description	Material	Note
1	Rail	Stainless steel	Heat treatment, Rust proof treatment
2	Guide	Stainless steel	Heat treatment
3	Retainer	Stainless steel	
4	Roller stopper A	Stainless steel	
5	Roller stopper B	Stainless steel	
6	Table	Aluminum alloy	Hard anodized
7	Bracket	Stainless steel	
8	Base plate	Stainless steel	
9	Floating bushing A	Stainless steel	
10	Floating bushing B	Stainless steel	
11	Hexalobular socket head cap screw	Chrome molybdenum steel	Electroless nickel plating
12	Hexagon socket head cap screw	Chrome molybdenum steel	Zinc chromate treatment
13	Hexalobular socket flat head screw	Chrome molybdenum steel	Nickel plating
14	Steel ball	High carbon chromium bearing steel	
15	Compact cylinder		JCDQ

Mounting screw/Component parts

No.	Description	Material	Note
16	Hexagon socket head cap screw	Chrome molybdenum steel	Zinc chromate treatment

Revision history
------------------

## SMC Corporation

4-14-1, Sotokanda, Chiyoda-ku, Tokyo 101-0021 JAPAN

Tel: + 81 3 5207 8249 Fax: +81 3 5298 5362

URL <https://www.smcworld.com>

---

Note: Specifications are subject to change without prior notice and any obligation on the part of the manufacturer.  
© 2011 SMC Corporation All Rights Reserved