



Operation Manual

PRODUCT NAME

REGULATOR FOR CHEMICAL LIQUIDS

MODEL / Series / Product Number

LVR series

SMC Corporation

Contents

1. Safety Instructions	P2~P3
2. Specific Product Precautions	P4~P5
3. Applicable Fluids	P6
4. How to Order	P7
5. Flow-rate Characteristics	P8
6. Specifications	P9
7. Dimensions	P10
8. Troubleshooting	P11



Safety Instructions

These safety instructions are intended to prevent hazardous situations and/or equipment damage. These instructions indicate the level of potential hazard with the labels of “**Caution**,” “**Warning**” or “**Danger**.” They are all important notes for safety and must be followed in addition to International Standards (ISO/IEC)^{*1)}, and other safety regulations.

*1) ISO 4414: Pneumatic fluid power - General rules and safety requirements for systems and their components
ISO 4413: Hydraulic fluid power - General rules and safety requirements for systems and their components
IEC 60204-1: Safety of machinery - Electrical equipment of machines - Part 1: General requirements
ISO 10218-1: Robots and robotic devices - Safety requirements for industrial robots - Part 1: Robots
etc.



Danger

Danger indicates a hazard with a high level of risk which, if not avoided, will result in death or serious injury.



Warning

Warning indicates a hazard with a medium level of risk which, if not avoided, could result in death or serious injury.



Caution

Caution indicates a hazard with a low level of risk which, if not avoided, could result in minor or moderate injury.

Warning

1. The compatibility of the product is the responsibility of the person who designs the equipment or decides its specifications.

Since the product specified here is used under various operating conditions, its compatibility with specific equipment must be decided by the person who designs the equipment or decides its specifications based on necessary analysis and test results. The expected performance and safety assurance of the equipment will be the responsibility of the person who has determined its compatibility with the product. This person should also continuously review all specifications of the product referring to its latest catalog information, with a view to giving due consideration to any possibility of equipment failure when configuring the equipment.

2. Only personnel with appropriate training should operate machinery and equipment.

The product specified here may become unsafe if handled incorrectly. The assembly, operation and maintenance of machines or equipment including our products must be performed by an operator who is appropriately trained and experienced.

3. Do not service or attempt to remove product and machinery/equipment until safety is confirmed.

1. The inspection and maintenance of machinery/equipment should only be performed after measures to prevent falling or runaway of the driven objects have been confirmed.
2. When the product is to be removed, confirm that the safety measures as mentioned above are implemented and the power from any appropriate source is cut, and read and understand the specific product precautions of all relevant products carefully.
3. Before machinery/equipment is restarted, take measures to prevent unexpected operation and malfunction.

4. Our products cannot be used beyond their specifications. Our products are not developed, designed, and manufactured to be used under the following conditions or environments. Use under such conditions or environments is not covered.

1. Conditions and environments outside of the given specifications, or use outdoors or in a place exposed to direct sunlight.
2. Use for nuclear power, railways, aviation, space equipment, ships, vehicles, military application, equipment affecting human life, body, and property, fuel equipment, entertainment equipment, emergency shut-off circuits, press clutches, brake circuits, safety equipment, etc., and use for applications that do not conform to standard specifications such as catalogs and operation manuals.
3. Use for interlock circuits, except for use with double interlock such as installing a mechanical protection function in case of failure. Please periodically inspect the product to confirm that the product is operating properly.



Safety Instructions

Caution

We develop, design, and manufacture our products to be used for automatic control equipment, and provide them for peaceful use in manufacturing industries.

Use in non-manufacturing industries is not covered.

Products we manufacture and sell cannot be used for the purpose of transactions or certification specified in the Measurement Act.

The new Measurement Act prohibits use of any unit other than SI units in Japan.

Limited warranty and Disclaimer/Compliance Requirements

The product used is subject to the following “Limited warranty and Disclaimer” and “Compliance Requirements”. Read and accept them before using the product.

Limited warranty and Disclaimer

1. The warranty period of the product is 1 year in service or 1.5 years after the product is delivered, whichever is first.*2)
Also, the product may have specified durability, running distance or replacement parts. Please consult your nearest sales branch.
2. For any failure or damage reported within the warranty period which is clearly our responsibility, a replacement product or necessary parts will be provided.
This limited warranty applies only to our product independently, and not to any other damage incurred due to the failure of the product.
3. Prior to using SMC products, please read and understand the warranty terms and disclaimers noted in the specified catalog for the particular products.

***2) Vacuum pads are excluded from this 1 year warranty.**

A vacuum pad is a consumable part, so it is warranted for a year after it is delivered.

Also, even within the warranty period, the wear of a product due to the use of the vacuum pad or failure due to the deterioration of rubber material are not covered by the limited warranty

Compliance Requirements

1. The use of SMC products with production equipment for the manufacture of weapons of mass destruction (WMD) or any other weapon is strictly prohibited.
2. The exports of SMC products or technology from one country to another are governed by the relevant security laws and regulations of the countries involved in the transaction. Prior to the shipment of a SMC product to another country, assure that all local rules governing that export are known and followed.



Series LVR Specific Product Precautions 1

Be sure to read this before handling. Refer to the back cover for Safety Instructions.

For 2 Port Solenoid Valves for Fluid Control, refer to "Handling Precautions for SMC Products" and the Operation Manual on SMC website, <http://www.smcworld.com>

Design / Selection

Warning

1. Check the specifications.

Give careful consideration to operating conditions such as the application, fluid and environment, and use within the operating ranges specified in this catalog.

2. Fluids

Operate after confirming the compatibility of the product's component materials with fluids, using the check list on page 6. Please contact SMC regarding fluids other than those in the check list.

3. Fluid pressure range

Keep the supplied fluid pressure within the operating pressure range shown in the catalog.

4. Ambient environment

Operate within the ambient operating temperature range. After confirming the compatibility of the product's component materials with the ambient environment, operate so that fluid does not adhere to the product's exterior surfaces.

5. Maintenance space

Ensure the necessary space for maintenance and inspections.

6. Liquid seals

When circulating fluid:

Provide a relief valve in the system so that fluid does not get into the liquid seal circuit.

If the inlet pressure is released with the pressure enclosed at the outlet pressure, the outlet pressure (residual pressure at the outlet side) cannot be released.

7. Countermeasures for static electricity

Since static electricity may be generated depending on the fluid being used, implement suitable countermeasures.

Caution

1. Pressure increase in the closed circuit

If the product is used with a closed circuit, the outlet pressure increases when valve leakage occurs. If the outlet side is closed, install a bypass circuit to make the circuit open.

Mounting

Warning

1. Breathing ports

If the direct suction and exhaust are not desired due to ambient environment or dust dispersion, connect additional piping so that suction and exhaust are performed in a clean location.

No corrosive fluids should not be entered into the vent hole. Malfunction may occur due to corrosion of components.

2. If air leakage increases or equipment does not operate properly, stop operation.

After mounting, perform suitable function and leak tests to confirm that the mounting is correct.

3. Operation Manual

Mount and operate the product after reading the Operation Manual carefully and understanding its contents. Also, keep the manual where it can be referred to as necessary.

Piping

Caution

1. Preparation before piping

Before piping is connected, it should be thoroughly blown out with air (flushing) or washed to remove chips, cutting oil and other debris from inside the pipe.

Install piping so that it does not apply pulling, pressing, bending or other forces on the valve body.

2. Use the tightening torques shown below when making connections to the pilot port.

Pilot Port Tightening Torque

Operating port	Torque lbf-ft [N·m]
Rc, NPT1/8	0.6 to 0.7 [0.8 to 1.0]

3. Use of metal fittings

Do not connect a metal fitting to the port. This will damage the thread.

4. Breathing ports

If the direct suction and exhaust are not desired due to ambient environment or dust dispersion, connect additional piping so that suction and exhaust are performed in a clean location.

No corrosive fluids should not be entered into the vent hole. Malfunction may occur due to corrosion of components.

5. For information on tubing connection, refer to the pamphlets "High Purity Fluoropolymer Fittings Hyper Fitting Series LQ1/2 Work Procedure Instructions" (M-E05-1) or "Flare Type Series LQ3 Fitting Procedure" (M-E06-4). (The pamphlets can be downloaded from the SMC website.)

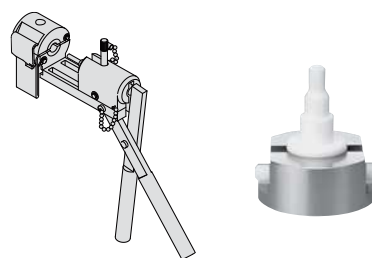

6. Tighten the nut to the end surface of the body. As a guide, refer to the proper tightening torques shown below.

Tightening Torque for Piping

Fitting nut size	LQ3	LQ1
2	1.6 to 1.8	0.3 to 0.4
3	3.2 to 3.5	0.8 to 1.0
4	5.0 to 5.3	1.0 to 1.2
5	10.0 to 10.5	2.5 to 3.0



Series LVR Specific Product Precautions 2

Be sure to read this before handling. Refer to the back cover for Safety Instructions.

For 2 Port Solenoid Valves for Fluid Control, refer to "Handling Precautions for SMC Products" and the Operation Manual on SMC website, <http://www.smcworld.com>

Operating Air Supply

Warning

1. Use clean air.

Do not use compressed air which includes chemicals, synthetic oils containing organic solvents, salt, or corrosive gases, etc., as this may cause damage or malfunction.

Caution

1. When adjusting the pilot pressure, the SMC precision regulators IR or ARP series are recommended.

Operating Environment

Warning

1. Do not use in a location having an explosive atmosphere.
2. Do not operate in locations where vibration or impact occurs.
3. Do not use in locations where radiated heat will be received from nearby heat sources.

Maintenance

Warning

1. Maintenance should be performed in accordance with the procedures in the Operation Manual.
Incorrect handling can cause damage or malfunction of machinery and equipment, etc.
2. Before removing equipment or compressed air supply/exhaust devices, shut off the air and power supplies, and exhaust compressed air from the system. Further, when restarting equipment after remounting or replacement, first confirm safety and then check the equipment for normal operation.
3. Perform work after removing residual chemicals and carefully replacing them with DI water (deionized water) or air, etc.
4. Do not disassemble the product. Products which have been disassembled cannot be guaranteed.
5. In order to obtain optimum performance from valves, perform periodic inspections to confirm that there are no leaks from valves or fittings, etc.

Caution

1. Removal of drainage

Flush drainage from filters regularly.

Pressure Adjustment

Warning

1. Check the inlet, outlet and pilot pressure indicators while undertaking pressure and flow settings.

Pressures over the regulated range may cause damage to the internal parts.

Caution

1. Without consumption of the outlet side flow, the outlet pressure will not decrease along with the pilot pressure decrease.

As this product is not fitted with a relief mechanism, without consumption of the outlet side flow, the outlet pressure will not decrease along with the pilot pressure decrease.

2. Set the outlet pressure to no more than 80% of the supply pressure.
3. When adjusting the flow, provide a restrictor on the outlet side of the product.
Without a restrictor, the stable adjustment of the flow cannot be achieved.
4. When the inlet pressure is fluctuating, take caution to the setting value of the outlet pressure.
When the setting value of the outlet pressure is over the inlet pressure, the outlet pressure cannot be stabilized.



Applicable Fluids

Regulator for Chemical Liquids Material and Fluid Compatibility Check List

Chemical	Compatibility
Acetone	<input type="radio"/> Note 1, 2)
Ammonium hydroxide	<input type="radio"/> Note 2)
Isobutyl alcohol	<input type="radio"/> Note 1, 2)
Isopropyl alcohol	<input type="radio"/> Note 1, 2)
Hydrochloric acid	<input type="radio"/> Note 2)
Ozone	<input type="radio"/>
Hydrogen peroxide Concentration 5% or less, Temperature 50°C or less	<input type="radio"/>
Ethyl acetate	<input type="radio"/> Note 1, 2)
Butyl acetate	<input type="radio"/> Note 1, 2)
Nitric acid (except fuming nitric acid) Concentration 10% or less	<input type="radio"/> Note 2)
Deionized water	<input type="radio"/>
Sodium hydroxide Concentration 50% or less	<input type="radio"/>
Nitrogen gas	<input type="radio"/>
Ultrapure water	<input type="radio"/>
Toluene	<input type="radio"/> Note 1, 2)
Hydrofluoric acid	<input type="radio"/> Note 2)
Sulfuric acid (except fuming sulfuric acid)	<input type="radio"/> Note 2)
Phosphoric acid Concentration 80% or less	<input type="radio"/>

Table symbols
○ : Can be used.
○ : Can be used under certain conditions.
x : Cannot be used.

The material and fluid compatibility check list provides reference values as a guide only.

Note 1) Since static electricity may be generated, implement suitable countermeasures.

Note 2) Use caution as permeation may occur. The permeated fluid may effect the parts of other materials.

- Compatibility is indicated for fluid temperatures of 100°C or less.
- The material and fluid compatibility check list provides reference values as a guide only, therefore we do not guarantee the application to our product.
- The data above is based on the information presented by the material manufacturers.
- SMC is not responsible for its accuracy and any damage happened because of this data.

Regulator for Chemical Liquids

Series LVR



How to Order

Integral fittings

LVR **2** 0 - **Z** **07** □

Body class

Symbol	Body class
2	2
4	4
5	5

Pilot port thread type

Symbol	Type
Nil	Rc
N	NPT

Fitting type

Symbol	Model
V	LQ1
Z	LQ3

Applicable tubing size

LQ1

Metric size

Symbol	Applicable tubing size	Applicable model		
		LVR20	LVR40	LVR50
03	3 x 2	●		
04	4 x 3	●		
06	6 x 4	○		
10	10 x 8		●	
12	12 x 10		○	●
19	19 x 16			○

Inch size

Symbol	Applicable tubing O.D.	Applicable model		
		LVR20	LVR40	LVR50
03	1/8" x 0.086"	●		
05	3/16" x 1/8"	●		
07	1/4" x 5/32"	○		
11	3/8" x 1/4"		●	
13	1/2" x 3/8"		○	●
19	3/4" x 5/8"			○

LQ3

Metric size

Symbol	Applicable tubing size	Applicable model		
		LVR20	LVR40	LVR50
06	6 x 4	○		
12	12 x 10		○	
19	19 x 16			○

Inch size

Symbol	Applicable tubing O.D.	Applicable model		
		LVR20	LVR40	LVR50
07	1/4" x 5/32"	○		
11	3/8" x 1/4"		○	
13	1/2" x 3/8"		○	
19	3/4" x 5/8"			○

○: Basic size ●: With reducer

Tube extensions

LVR **2** 0 - **T** **07** □

Body class

Symbol	Body class
2	2
4	4

Pilot port thread type

Symbol	Type
Nil	Rc
N	NPT

Tube extensions

Tubing size

Metric size

Symbol	Tubing size	Applicable model	
		LVR20	LVR40
06	6 x 4	○	
10	10 x 8		○

Inch size

Symbol	Tubing O.D.	Applicable model	
		LVR20	LVR40
07	1/4" x 5/32"	○	
11	3/8" x 1/4"		○

Series LVR

Flow-rate Characteristics (Representative Value)

Inlet pressure: 44 psi (0.3 MPa) Fluid: Water

LVR20

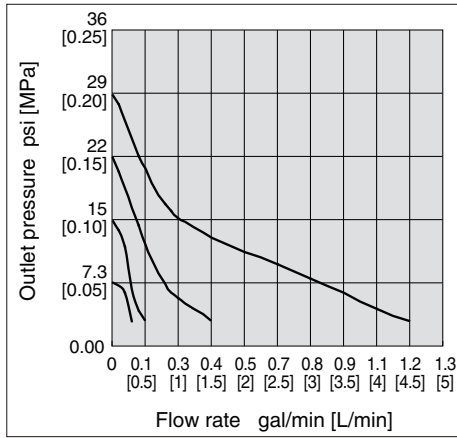

LVR40

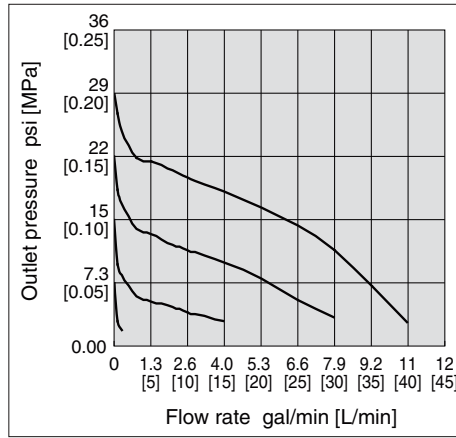

LVR50

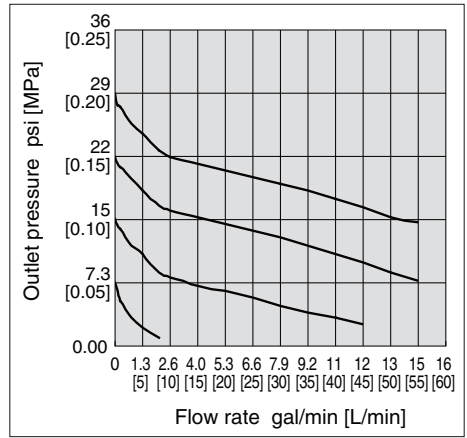

Input/Output Characteristics: Flow Rate (Representative Value)

Inlet pressure: 44 psi (0.3 MPa) Fluid: Water

LVR20

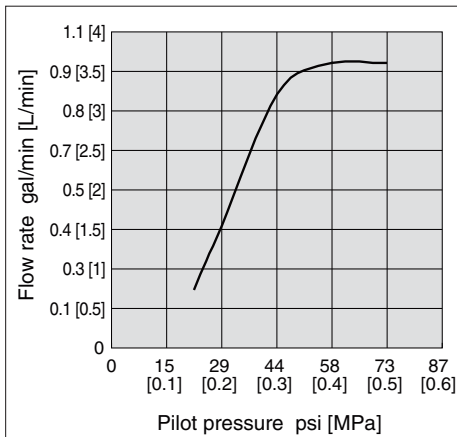

LVR40

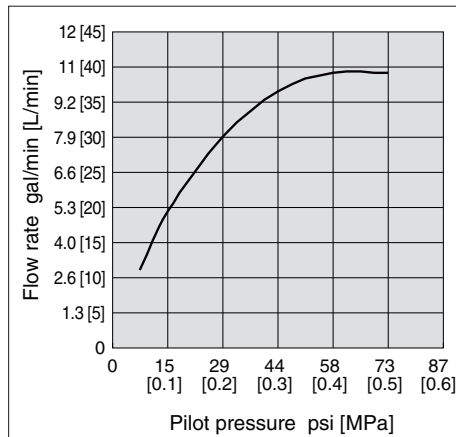

LVR50

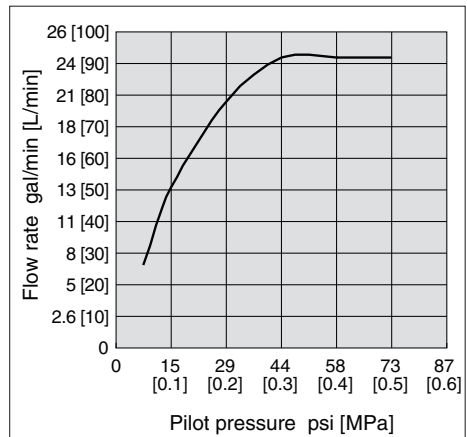

Input/Output Characteristics: Outlet Pressure (Representative Value)

Inlet pressure: 44 psi (0.3 MPa) Fluid: Water

LVR20

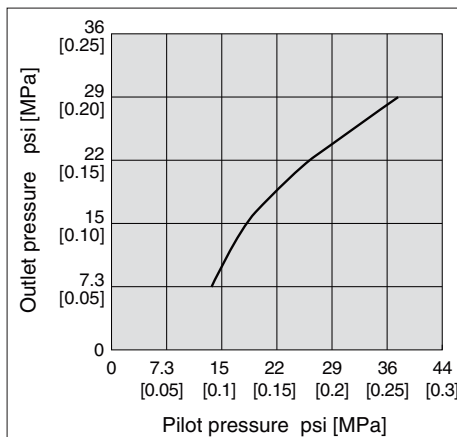

LVR40

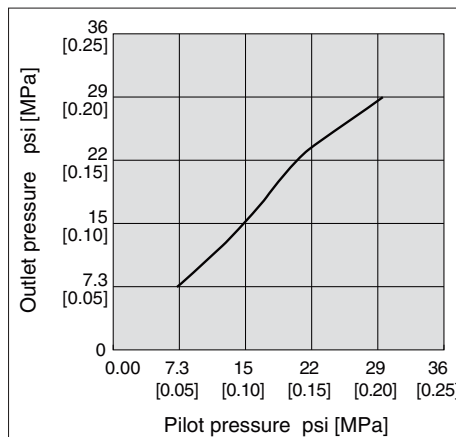

LVR50

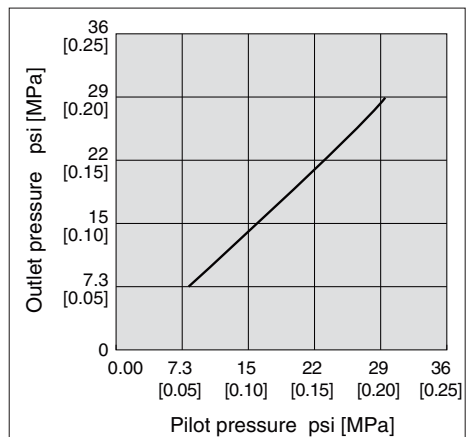

Specifications



Model	LVR20	LVR40	LVR50
Maximum operating pressure psi [MPa]	73 [0.5]		
Set pressure range psi [MPa]	2.9 to 58 [0.02 to 0.4]		
Pilot pressure psi [MPa]	73 [0.5]		
Withstand pressure psi [MPa]	145 [1.0]		
Fluid	Deionized water, Chemical liquids		
Fluid temperature °F [°C]	32 to 212 [0 to 100]		
Ambient temperature °F [°C]	32 to 140 [0 to 60]		
Parts in contact with fluid	Diaphragm	PTFE	
	Body	PFA	

Construction

Integral fittings/LQ3

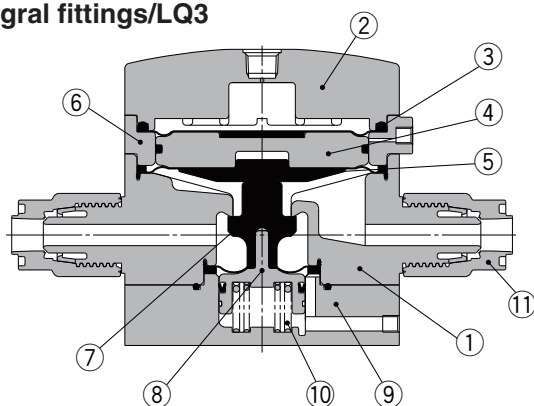

Component Parts

No.	Description	Material	Note
1	Body	PFA	
2	Housing	PVDF	
3	Diaphragm	FKM	
4	Plate	PVDF	
5	Diaphragm	PTFE	
6	Housing	PVDF	
7	Diaphragm	PTFE	
8	Guide	PPS	
9	End plate	PVDF	
10	Spring	Stainless steel	Fluorine coated
11	Nut	PFA	

Integral fittings/LQ1

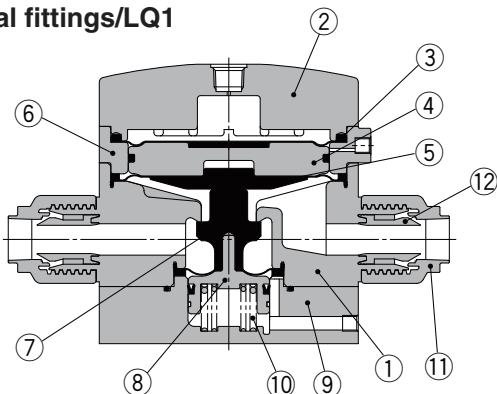

Component Parts

No.	Description	Material	Note
1	Body	PFA	
2	Housing	PVDF	
3	Diaphragm	FKM	
4	Plate	PVDF	
5	Diaphragm	PTFE	
6	Housing	PVDF	
7	Diaphragm	PTFE	
8	Guide	PPS	
9	End plate	PVDF	
10	Spring	Stainless steel	Fluorine coated
11	Nut	PFA	
12	Insert bushing	PFA	

Tube extensions

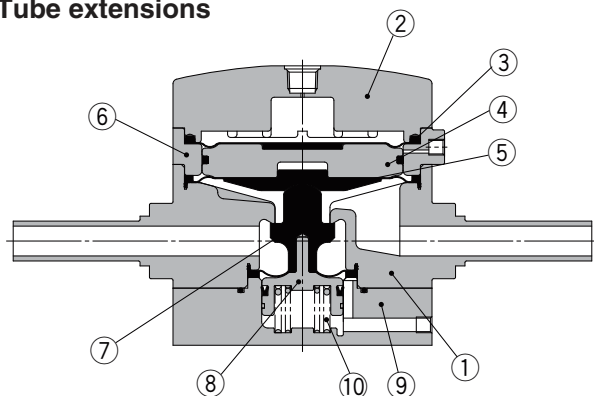

Component Parts

No.	Description	Material	Note
1	Body	PFA	
2	Housing	PVDF	
3	Diaphragm	FKM	
4	Plate	PVDF	
5	Diaphragm	PTFE	
6	Housing	PVDF	
7	Diaphragm	PTFE	
8	Guide	PPS	
9	End plate	PVDF	
10	Spring	Stainless steel	Fluorine coated

Series LVR

Dimensions

Integral fittings/LQ3

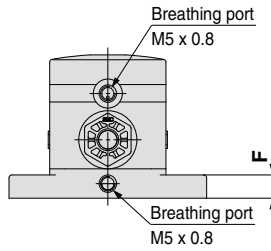
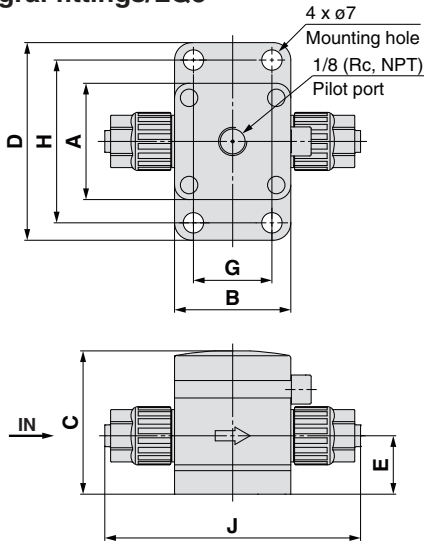

Model	A	B	C	D	E
LVR20-Z07(06)	40	40	49.3	68	20.1
LVR40-Z11(10)	82.5	82.5	89	115	33
LVR40-Z13(12)	82.5	82.5	89	115	33
LVR50-Z19	100	100	117.5	135	45

Model	F	G	H	J
LVR20-Z07(06)	8	27	56	88
LVR40-Z11(10)	14	64.5	100	150.5
LVR40-Z13(12)	14	64.5	100	159.5
LVR50-Z19	22	80	120	189

Integral fittings/LQ1

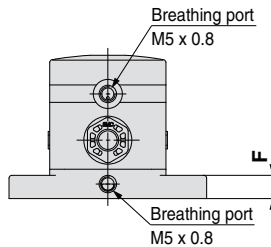
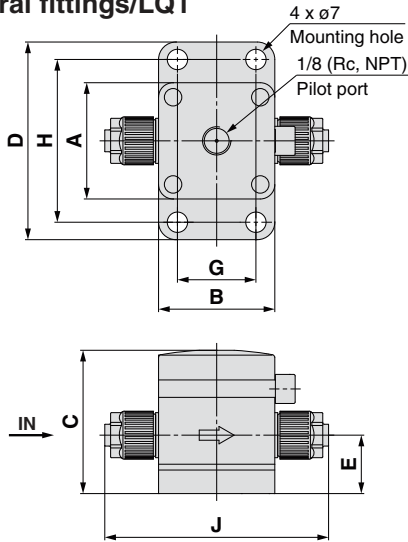

Model	A	B	C	D	E
LVR20-V07(06)	40	40	49.3	68	20.1
LVR40-V11(10)	82.5	82.5	89	115	33
LVR40-V13(12)	82.5	82.5	89	115	33
LVR50-V19	100	100	117.5	135	45

Model	F	G	H	J
LVR20-V07(06)	8	27	56	77
LVR40-V11(10)	14	64.5	100	140.5
LVR40-V13(12)	14	64.5	100	140.5
LVR50-V19	22	80	120	169

Tube extensions

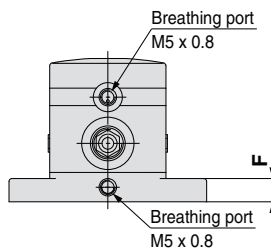
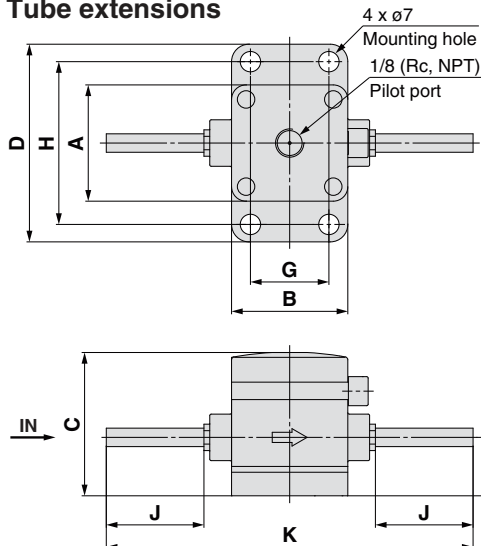

Model	A	B	C	D	E
LVR20-T07(06)	40	40	49.3	68	20.1
LVR40-T11(10)	82.5	82.5	89	115	33

Model	F	G	H	J	K
LVR20-T07(06)	8	27	56	33.5	126.2
LVR40-T11(10)	14	64.5	100	40	183.3

Troubleshooting

Trouble	Possible Cause	Remedy
Pressure is not regulated	Opposite flow direction or opposite installation of regulator.	Check flow direction and install the regulator correctly if wrong.
	Breakage of valve	Replace the product with new one.
	Breakage of valve seat.	
	Breakage of pilot diaphragm.	
Fluid leaks to outside from the product.	Connection of the product becomes loosened.	Replace the product with new one.
	Breakage of diaphragm and valve diaphragm.	
Pilot air leaks to outside from the product.	Connection of the product becomes loosened.	Replace the product with new one.
	Breakage of pilot diaphragm.	

Revision history

A:Creating a new chart by changing Specifications.
B:Safety Instructions changed.

SMC Corporation

Tel: + 81 3 5207 8249 Fax: +81 3 5298 5362
URL <https://www.smcworld.com>

Note: Specifications are subject to change without prior notice and any obligation on the part of the manufacturer.
© SMC Corporation All Rights Reserved