



# Operation Manual

PRODUCT NAME

SI Unit for Vacuum Manifold

MODEL / Series / Product Number

*EX260-VPN1*

**SMC Corporation**

# Contents

Safety Instructions	3
1. Product summary	10
2. Wiring	11
2.1. Fieldbus interface connector	11
2.2. Power supply connector	13
2.3. FE terminal	14
3. Configuration	15
3.1. GSD file and symbol file	15
3.2. Head modules	15
3.3. Modules	16
3.4. Sub modules	17
3.5. Configuration steps	18
4. Parameter	19
4.1. Module parameters for Vacuum / Release module	19
5. Process data	23
5.1. Process data on Vacuum / Release module	23
5.2. Process data of Pressure value / Channel status module	27
5.3. Process data of Unit status module	28
6. RecordData	29
6.1. User specific RecordData	29
7. LED Indication and Alarm	30
7.1. LED Indication	30
7.2. Alarm	32
8. Specification	33
8.1. Dimensions	33
8.2. Specifications	34
9. Accessories	35
10. Troubleshooting	41



# Safety Instructions

These safety instructions are intended to prevent hazardous situations and/or equipment damage. These instructions indicate the level of potential hazard with the labels of “**Caution**,” “**Warning**” or “**Danger**.” They are all important notes for safety and must be followed in addition to International Standards (ISO/IEC)<sup>\*1</sup>, and other safety regulations.

\*1) ISO 4414: Pneumatic fluid power - General rules and safety requirements for systems and their components  
ISO 4413: Hydraulic fluid power - General rules and safety requirements for systems and their components  
IEC 60204-1: Safety of machinery - Electrical equipment of machines - Part 1: General requirements  
ISO 10218-1: Robots and robotic devices - Safety requirements for industrial robots - Part 1: Robots  
etc.

	<b>Danger</b>	<b>Danger</b> indicates a hazard with a high level of risk which, if not avoided, will result in death or serious injury.
	<b>Warning</b>	<b>Warning</b> indicates a hazard with a medium level of risk which, if not avoided, could result in death or serious injury.
	<b>Caution</b>	<b>Caution</b> indicates a hazard with a low level of risk which, if not avoided, could result in minor or moderate injury.

## **Warning**

### **1. The compatibility of the product is the responsibility of the person who designs the equipment or decides its specifications.**

Since the product specified here is used under various operating conditions, its compatibility with specific equipment must be decided by the person who designs the equipment or decides its specifications based on necessary analysis and test results. The expected performance and safety assurance of the equipment will be the responsibility of the person who has determined its compatibility with the product. This person should also continuously review all specifications of the product referring to its latest catalog information, with a view to giving due consideration to any possibility of equipment failure when configuring the equipment.

### **2. Only personnel with appropriate training should operate machinery and equipment.**

The product specified here may become unsafe if handled incorrectly. The assembly, operation and maintenance of machines or equipment including our products must be performed by an operator who is appropriately trained and experienced.

### **3. Do not service or attempt to remove product and machinery/equipment until safety is confirmed.**

1. The inspection and maintenance of machinery/equipment should only be performed after measures to prevent falling or runaway of the driven objects have been confirmed.
2. When the product is to be removed, confirm that the safety measures as mentioned above are implemented and the power from any appropriate source is cut, and read and understand the specific product precautions of all relevant products carefully.
3. Before machinery/equipment is restarted, take measures to prevent unexpected operation and malfunction.

### **4. Our products cannot be used beyond their specifications. Our products are not developed, designed, and manufactured to be used under the following conditions or environments. Use under such conditions or environments is not covered.**

1. Conditions and environments outside of the given specifications, or use outdoors or in a place exposed to direct sunlight.
2. Use for nuclear power, railways, aviation, space equipment, ships, vehicles, military application, equipment affecting human life, body, and property, fuel equipment, entertainment equipment, emergency shut-off circuits, press clutches, brake circuits, safety equipment, etc., and use for applications that do not conform to standard specifications such as catalogs and operation manuals.
3. Use for interlock circuits, except for use with double interlock such as installing a mechanical protection function in case of failure. Please periodically inspect the product to confirm that the product is operating properly.



# Safety Instructions

## Caution

**We develop, design, and manufacture our products to be used for automatic control equipment, and provide them for peaceful use in manufacturing industries. Use in non-manufacturing industries is not covered.**

Products we manufacture and sell cannot be used for the purpose of transactions or certification specified in the Measurement Act.

The new Measurement Act prohibits use of any unit other than SI units in Japan.

## Limited warranty and Disclaimer/Compliance Requirements

The product used is subject to the following “Limited warranty and Disclaimer” and “Compliance Requirements”.

Read and accept them before using the product.

### Limited warranty and Disclaimer

1. The warranty period of the product is 1 year in service or 1.5 years after the product is delivered, whichever is first.\*2)  
Also, the product may have specified durability, running distance or replacement parts. Please consult your nearest sales branch.
2. For any failure or damage reported within the warranty period which is clearly our responsibility, a replacement product or necessary parts will be provided.  
This limited warranty applies only to our product independently, and not to any other damage incurred due to the failure of the product.
3. Prior to using SMC products, please read and understand the warranty terms and disclaimers noted in the specified catalog for the particular products.

**\*2) Vacuum pads are excluded from this 1 year warranty.**

A vacuum pad is a consumable part, so it is warranted for a year after it is delivered.

Also, even within the warranty period, the wear of a product due to the use of the vacuum pad or failure due to the deterioration of rubber material are not covered by the limited warranty

### Compliance Requirements

1. The use of SMC products with production equipment for the manufacture of weapons of mass destruction (WMD) or any other weapon is strictly prohibited.
2. The exports of SMC products or technology from one country to another are governed by the relevant security laws and regulations of the countries involved in the transaction. Prior to the shipment of a SMC product to another country, assure that all local rules governing that export are known and followed.

## Operator

- ◆ This operation manual is intended for those who have knowledge of machinery using pneumatic equipment, and have sufficient knowledge of assembly, operation and maintenance of such equipment. Only those persons are allowed to perform assembly, operation and maintenance.
- ◆ Read and understand this operation manual carefully before assembling, operating or providing maintenance to the product.

### ■ Safety Instructions

#### Warning

- Do not disassemble, modify (including changing the printed circuit board) or repair.  
An injury or failure can result.
- Do not operate or set up with wet hands.  
An electric shock can result.
- Do not operate the product outside of the specifications.  
Do not use for flammable or harmful fluids.  
Fire, malfunction, or damage to the product can result.  
Verify the specifications before use.
- Do not operate in an atmosphere containing flammable or explosive gases.  
Fire or an explosion can result.  
This product is not designed to be explosion proof.
- If using the product in an interlocking circuit:
  - Provide a double interlocking system, for example a mechanical system.
  - Check the product regularly for proper operation.Otherwise, malfunction can result, causing an accident.
- The following instructions must be followed during maintenance:
  - Turn off the power supply.
  - Stop the air supply, exhaust the residual pressure and verify that the air is released before performing maintenance.Otherwise, an injury can result.

## **Caution**

- When handling or assembling or replacing the unit, pay attention to the following:
  - Do not touch the sharp edges when handling the unit
  - The unit joints are tightly bound with gaskets, so do not hit your hands when replacing the unit.
  - Do not put your fingers between them when joining the units.Otherwise, an injury can result.

- After maintenance is complete, perform appropriate functional inspections.  
Stop operation if the equipment does not function properly.  
Safety cannot be assured in the case of unexpected malfunction.

- Provide grounding to assure the noise resistance of the Serial System.  
Individual grounding should be provided close to the product with a short cable.

## **NOTE**

- Follow the instructions given below when designing, selecting and handling the product.
- The instructions on design and selection (installation, wiring, environment, adjustment, operation, maintenance, etc.) described below must also be followed.
  - \*Product specifications
    - Use the specified voltage.  
Otherwise, failure or malfunction can result.
    - Reserve a space for maintenance.  
Allow sufficient space for maintenance when designing the system.
    - Do not remove any nameplates or labels.  
This can lead to incorrect maintenance, or misreading of the operation manual, which could cause damage or malfunction to the product.  
It may also result in non-conformity to safety standards.
    - Pay attention to the inrush current at power-up.  
Depending on the connected load, the initial charge current may cause the overcurrent protection and malfunction can result.

## •Product handling

### \*Installation

- Do not drop, hit or apply excessive shock to the fieldbus system.  
Otherwise, damage to the product can result, causing malfunction.
- Tighten to the specified tightening torque.  
If the tightening torque is exceeded the mounting screws may be broken.  
IP65 protection cannot be guaranteed if the screws are not tightened to the specified torque.
- When carrying the vacuum manifold, make sure that the connections are not stressed.  
Otherwise, the damage to connections can result. In addition, some combinations of the manifold may be very heavy, so use more than one person to carry or install the unit.
- Never mount a product in a location that will be used as a foothold.  
The product may be damaged if excessive force is applied by stepping or climbing onto it.

### \*Wiring

- Avoid repeatedly bending or stretching the cables, or placing heavy load on them.  
Repetitive bending stress or tensile stress can cause breakage of the cable.
- Wire correctly.  
Incorrect wiring can break the product.
- Do not perform wiring while the power is on.  
Otherwise, damage to the fieldbus system and/or I/O device can result, causing malfunction.
- Do not route wires and cables together with power or high voltage cables.  
Otherwise, the fieldbus system and/or I/O device can malfunction due to interference of noise and surge voltage from power and high voltage cables to the signal line.  
Route the wires (piping) of the fieldbus system and/or I/O device separately from power or high voltage cables.
- Confirm proper insulation of wiring.  
Poor insulation (interference from another circuit, poor insulation between terminals, etc.) can lead to excess voltage or current being applied to the product, causing damage.
- Take appropriate measures against noise, such as using a noise filter, when the fieldbus system is incorporated into equipment.  
Otherwise, noise can cause malfunction.

### \*Environment

- Select the proper type of protection according to the environment of operation.  
IP65 protection is achieved when the following conditions are met.
  - (1) The units are connected properly with fieldbus cable with M12 connector and power cable with M12 (M8) connector.
  - (2) Suitable mounting of each unit and vacuum manifold.
  - (3) Be sure to fit a seal cap on any unused connectors.

If using in an environment that is exposed to water splashes, please take measures such as using a cover.
- Do not use in a place where the product could be splashed by oil or chemicals.  
If the product is to be used in an environment containing oils or chemicals such as coolant or cleaning solvent, even for a short time, it may be adversely affected (damage, malfunction etc.).
- Do not use the product in an environment where corrosive gases or fluids could be splashed.  
Otherwise, damage to the product and malfunction can result.
- Do not use in an area where surges are generated.  
If there is equipment that generates a large amount of surge (solenoid type lifter, high frequency induction furnace, motor, etc.) close to the fieldbus system, this may cause deterioration or breakage of the internal circuit of the fieldbus system. Avoid sources of surge generation and crossed lines.
- When a surge-generating load such as a relay or solenoid is driven directly, use a fieldbus system with a built-in surge-absorbing element.  
Direct drive of a load generating surge voltage can damage the fieldbus system.
- The product is CE/UKCA marked, but not immune to lightning strikes. Take measures against lightning strikes in the system.
- Prevent foreign matter such as remnant of wires from entering the fieldbus system to avoid failure and malfunction.

- Mount the product in a place that is not exposed to vibration or impact.  
Otherwise, failure or malfunction can result.
- Do not use the product in an environment that is exposed to temperature cycle.  
Heat cycles other than ordinary changes in temperature can adversely affect the inside of the product.
- Do not expose the product to direct sunlight.  
If using in a location directly exposed to sunlight, shade the product from the sunlight.  
Otherwise, failure or malfunction can result.
- Keep within the specified ambient temperature range.  
Otherwise, malfunction can result.
- Do not operate close to a heat source, or in a location exposed to radiant heat.  
Otherwise, malfunction can result.

**\*Adjustment and Operation**

- Perform settings suitable for the operating conditions.  
Incorrect setting can cause operation failure.
- Please refer to the PLC manufacturer's manual etc. for details of programming and addresses.  
For the PLC protocol and programming refer to the relevant manufacturer's documentation.

**\*Maintenance**

- Turn off the power supply, stop the supplied air, exhaust the residual pressure and verify the release of air before performing maintenance.  
There is a risk of unexpected malfunction.
- Perform regular maintenance and inspections.  
There is a risk of unexpected malfunction.
- After maintenance is complete, perform appropriate functional inspections.  
Stop operation if the equipment does not function properly.  
Otherwise, safety is not assured due to an unexpected malfunction or incorrect operation.
- Do not use solvents such as benzene, thinner etc. to clean the each unit.  
They could damage the surface of the body and erase the markings on the body.  
Use a soft cloth to remove stains.  
For heavy stains, use a cloth soaked with diluted neutral detergent and fully squeezed, then wipe up the stains again with a dry cloth.



# Fieldbus System/ Industrial IoT Cybersecurity

In recent years, factories have introduced industrial IoT, building up complex networks of production machines. These systems may be subject to a new threat, cyberattack. To protect the industrial IoT from cyberattacks, it is important to take multiple measures (multi-layer protection) for IoT devices, networks and clouds.

For this purpose, SMC recommends that the following measures are always taken into consideration. For further details of the following measures, please see security information published by your local country security agencies.

## 1. Do not connect the devices via a public network.

- If you unavoidably need to access the device or cloud via a public network, ensure to use a secure, private network such as VPN.
- Do not connect an office IT network and factory IoT network.

## 2. Build a firewall to prevent a threat from entering the device and system.

- Set up a router or firewall at network boundaries to allow minimum required communications.
- Disconnect from the network or turn off the device, if no continuous connection is required.

## 3. Physically block an access to unused communication ports or disable them.

- Inspect regularly each port if any unnecessary device is connected to the network system.
- Operate necessary services (SSH, FTP, SFTP, etc.) only.
- Set a transmission range of the device using a wireless LAN or other radio system to the minimum required and use only devices approved according to the radio act in the country concerned.
- Install a device generating radio waves in such place as there is no interference from indoor or outdoor.

## 4. Set up a secure communication method such as data encryption.

- Encrypt data in every environment, including IoT networks, secure gate-way connections, for secure communications.

## 5. Grant access permissions by user accounts and limit the number of users.

- Regularly review accounts and delete all unused accounts or permissions.
- Establish an account lockout system to block an access to the account for a certain period if log-in fails more than the given threshold.

## 6. Protect passwords.

- Change the default password when you first use the device or system.
- Choose a long password (minimum 8 characters) using a mix of different letters and characters to make the password more secure and harder to hack.

## 7. Use the latest security software.

- Install antivirus software on all computers to detect and remove viruses.
- Keep the antivirus software up to date.

## 8. Use the latest version of the device and system software.

- Apply patches to keep the OS and applications up to date.

## 9. Monitor and detect abnormalities in the network.

- Keep monitoring the network for any abnormalities to take a prompt measure and issue an alert if any abnormality is detected. Install an intrusion detection system (IDS) and intrusion prevention system (IPS).

## 10. Delete data from devices when disposed of.

- Before disposing of any IoT devices, delete stored data or physically destruct media to prevent any misuse of the data.

# 1. Product summary

This document is an operation manual for a SI (Serial Interface) Unit which controls vacuum (ejector) manifold. The SI Unit is a PROFINET IO-device. The SI Unit controls a vacuum manifold which has 16 supply valves max., 16 release valves max. and 16 pressure sensors max..

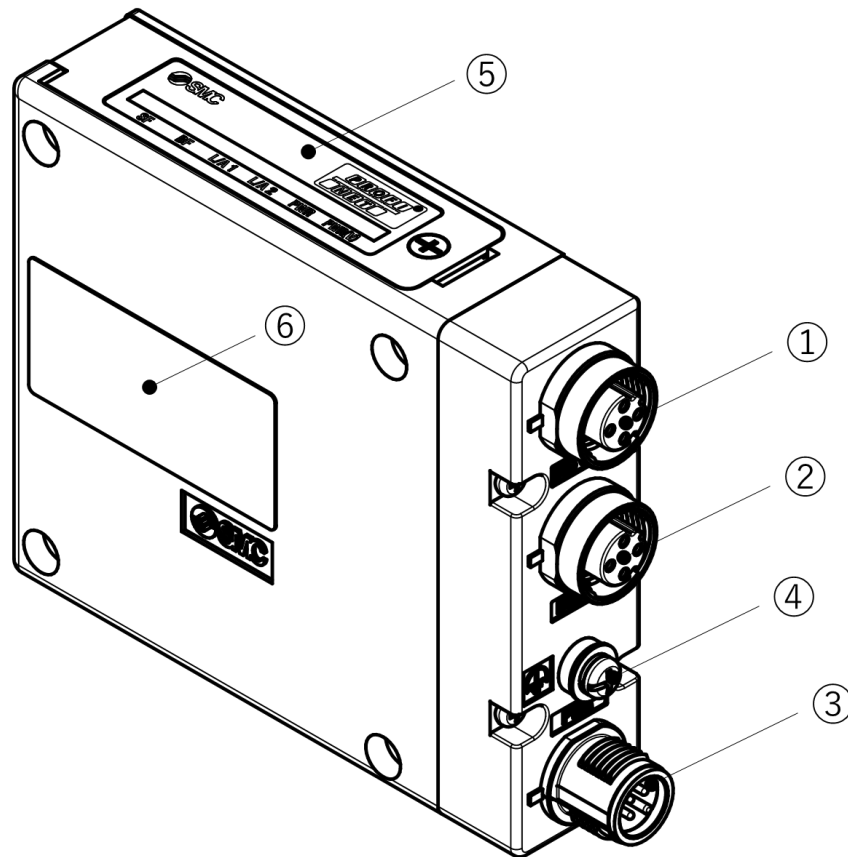

No.	Item	Description
1	Fieldbus interface connector (BUS OUT/Port2)	PROFINET connection Port 2. (M12 4 pin socket D-coded) Refer to <a href="#">Section 2.1</a> .
2	Fieldbus interface connector (BUS IN/Port1)	PROFINET connection Port 1. (M12 4 pin socket D-coded) Refer to <a href="#">Section 2.1</a> .
3	Power supply connector (PWR)	Power supply for logic/sensors and valves voltage. (M12 4 pin plug A-coded) Refer to <a href="#">Section 2.2</a> .
4	FE terminal	Functional earth. (M3 screw) Refer to <a href="#">Section 2.3</a> .
5	LED display	LED display to indicate the status of the SI Unit. Refer to <a href="#">Section 7.1</a> .
6	Product information label	Information label to indicate an information of the SI Unit such as MAC address or serial No. etc..

Fig. 1-1. The SI Unit structure

## Warning

The SI Unit should be powered with a suitable connection to the vacuum manifold.

## 2. Wiring

Select the appropriate cables to mate with the connectors mounted on the SI Unit, refer to [Section 9](#).

### 2.1. Fieldbus interface connector

BUS OUT/Port2: M12 4 pin socket D-coded (Port type: MDI-X)

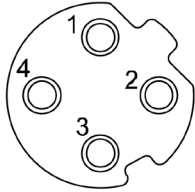

No.	Designation	Content
1	RD+	Receive Data +
2	TD+	Transmit Data +
3	RD-	Receive Data -
4	TD-	Transmit Data -

BUS IN/Port1: M12 4 pin socket D-coded (Port type: MDI)

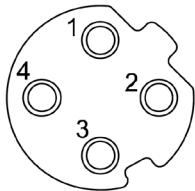

No.	Designation	Content
1	TD+	Transmit Data +
2	RD+	Receive Data +
3	TD-	Transmit Data -
4	RD-	Receive Data -

Fig. 2-1. Pin allocation of M12 4 pins socket D-coded connector

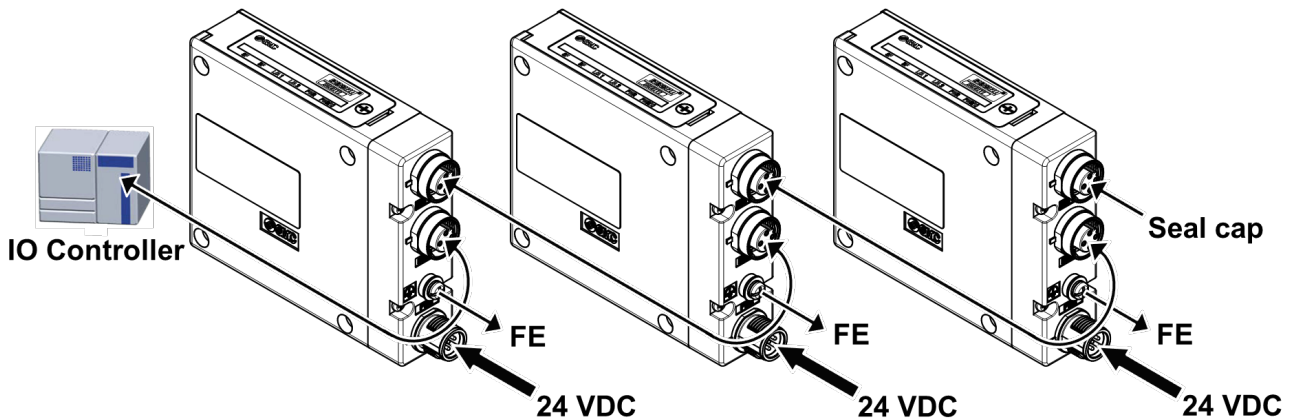

Fig. 2-2 Example of wiring layout

#### Caution

Be sure to fit a seal cap on any unused connectors. Proper use of the seal cap enables the enclosure to achieve IP65 specification, refer to [Section 9](#).

**NOTE**

- When the Autonegotiation function is unused, the correct network cable should be selected, refer to Fig 2-3.
- The Auto crossover function is available when the Autonegotiation function is used.
- The Auto crossover function shall be capable of switching over their twisted pair ports automatically between MDI and MDI-X pin assignment.  
When this function is enabled, proper selection of patch and crossover cables between port types MDI/MDI-X is no longer required. The Auto crossover function need to be disabled when using the FSU (Fast Start Up) function.

The following Fig. 2-3 shows wiring examples of the use of two cable types.

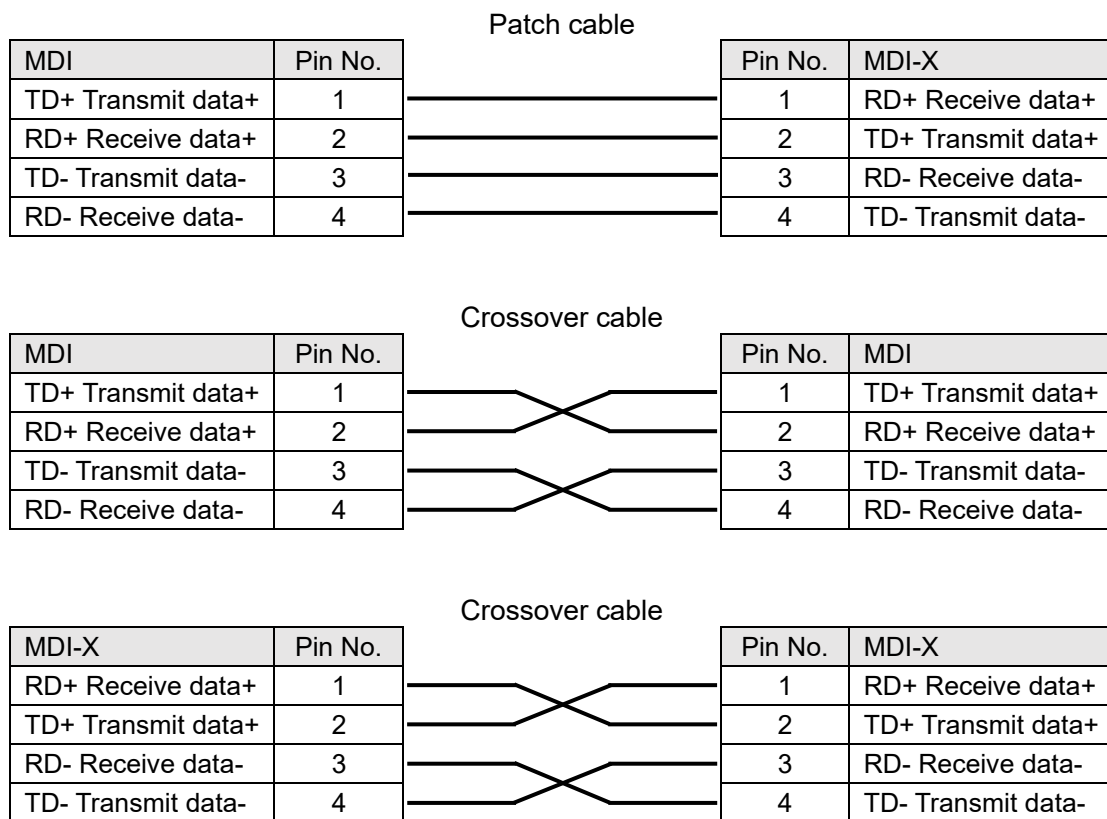
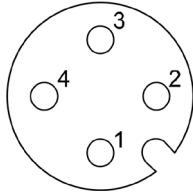

Fig. 2-3 Wiring example using patch and crossover cable

## 2.2. Power supply connector

PWR: M12 4 pin plug A-coded



No.	Designation	Content
1	SV24 V (PWR(V))	+24 V for valves
2	SV0 V (PWR(V))	0 V for valves
3	SI24 V (PWR)	+24 V for logic/sensors
4	SI0 V (PWR)	0 V for logic/sensors

Fig. 2-4 Pin allocation of M12 4 pin plug A-coded connector

Power-supply line for valves and power-supply line for logic/sensors operation are isolated. Be sure to supply power respectively. It can be used either with two different power supply or single-source power supply.

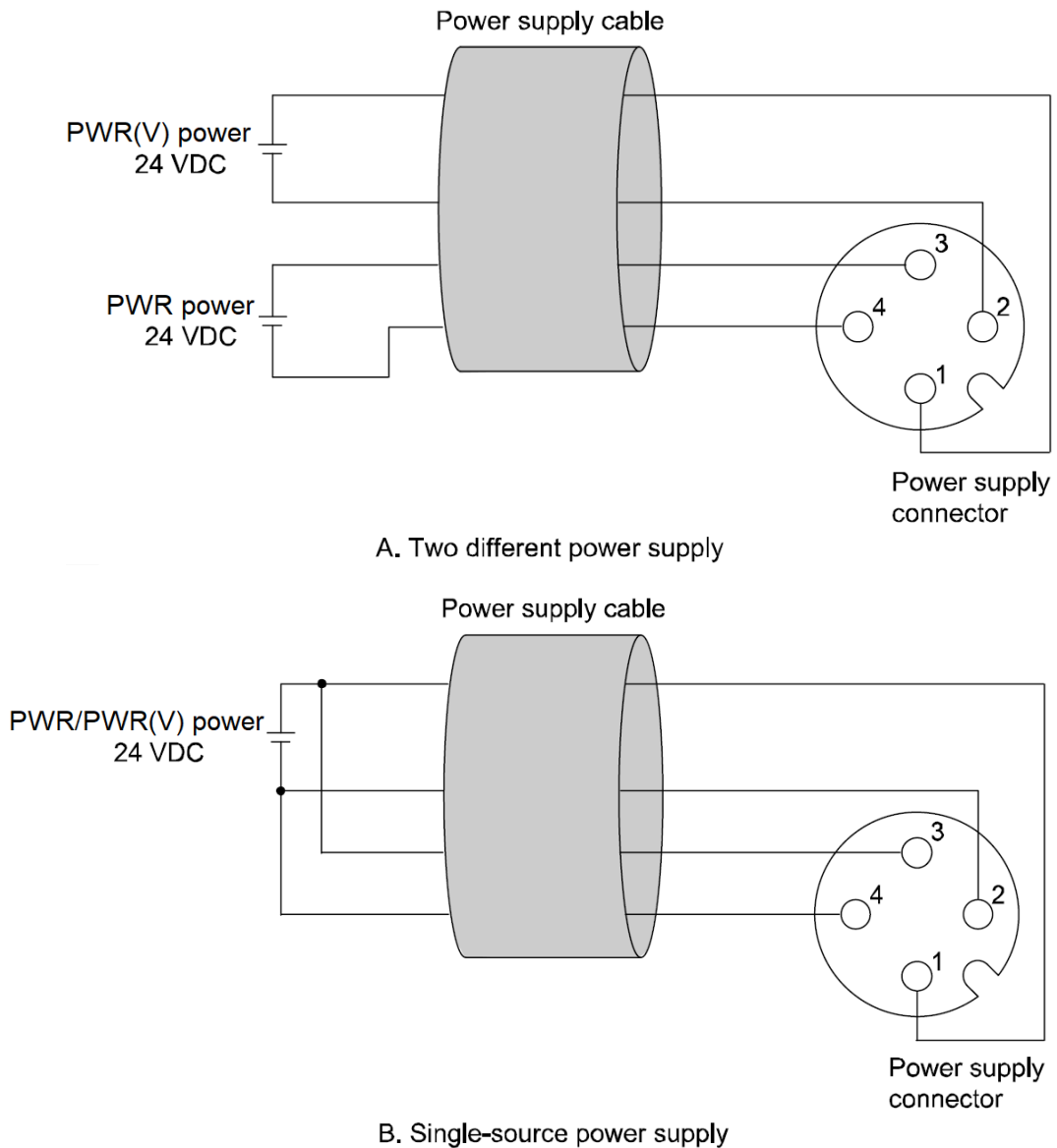

Fig. 2-5 Example of power supply layout

## 2.3. FE terminal

The SI Unit must be connected to FE (Functional Earth) to divert electromagnetic interference. For maximum protection, the FE cable should be as thick and short as reasonably possible. The FE terminal and the metal parts of the fieldbus interface/power supply connector are internally connected.

FE terminal screw tightening torque: 0.3 Nm.

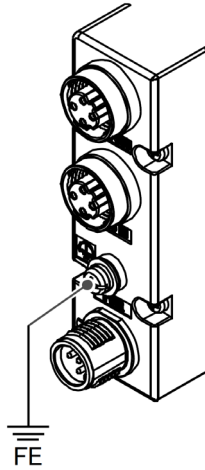

Fig. 2-6 FE terminal

## 3. Configuration

The SI Unit is a modular station that consists of several modules.  
Set up your PROFINET IO Controller's (PLC's) software to reflect the configuration of your system.

### 3.1. GSD file and symbol file

In order to configure the SI Unit with your PROFINET IO Controller's software, the dedicated GSD file is required. The GSD file contains all of the necessary information to configure the SI Unit on your PROFINET IO Controller's software.

In order to represent the SI Unit in your PROFINET IO Controller's software, the dedicated symbol file is required.

The GSD file and the symbol file names are as follows.

- GSD file : GSDML-V2.3x-SMC-EX260-VPN1-xxxxxxx.xml
- Symbol file : GSDML-0083-0012-EX260-VPN1.bmp

### 3.2. Head modules

The GSD file contains the following four head modules.  
Select the head module according to the number of ejectors connected.

Table. 3-1 Head modules

Head module	Number of ejectors connected
EX260-VPN1 ( 4 )	1...4
EX260-VPN1 ( 8 )	5...8
EX260-VPN1 (12)	9...12
EX260-VPN1 (16)	13...16

### 3.3. Modules

The GSD file contains the following modules.

The number of occupied bytes of some modules differ by the selected head module.

Table. 3-2 Overview of modules for the SI Unit

Module	Selected head module	Occupied bytes		Allowable slot	Note
		Input	Output		
Vacuum / Release	EX260-VPN1 ( 4) EX260-VPN1 ( 8)	2 bytes	2 bytes	Vacuum / Release	Refer to <a href="#">Section 5.1.</a>
	EX260-VPN1 (12) EX260-VPN1 (16)	4 bytes	4 bytes		
Vacuum / Release shared	EX260-VPN1 ( 4) EX260-VPN1 ( 8)	2 bytes	2 bytes	Vacuum / Release	Refer to <a href="#">Section 3.4</a> and <a href="#">Section 5.1.</a>
	EX260-VPN1 (12) EX260-VPN1 (16)	4 bytes	4 bytes		
Pressure value / Channel status	-	2 bytes	-	Pressure value / Channel status 0...15	Refer to <a href="#">Section 5.2.</a>
Pressure value / Channel status shared	-	2 bytes	-	Pressure value / Channel status 0...15	Refer to <a href="#">Section 3.4</a> and <a href="#">Section 5.2.</a>
Unit status	-	1 byte	-	Unit status	Refer to <a href="#">Section 5.3.</a>
Unit status shared	-	1 byte	-	Unit status	Refer to <a href="#">Section 3.4</a> and <a href="#">Section 5.3.</a>



### 3.4. Sub modules

Using the module named as “shared”, other PROFINET IO Controllers can use the copied input data in the same slot.

The number of occupied bytes of some sub modules differ by the selected head module.

Table. 3-3 Overview of Sub modules for the SI Unit

Module	Sub Module	Selected head module	Occupied bytes		Note
			Input	Output	
Vacuum / Release shared	Vacuum / Release	EX260-VPN1 ( 4) EX260-VPN1 ( 8)	2 bytes	2 bytes	Sub module for control. Refer to <a href="#">Section 5.1</a> .
		EX260-VPN1 (12) EX260-VPN1 (16)	4 bytes	4 bytes	
	Shared inputs	EX260-VPN1 ( 4) EX260-VPN1 ( 8)	4 bytes	-	Sub module for copied data. 2(4) bytes input data for vacuum/release confirmation and 2(4) bytes output data for vacuum/release instruction are copied.
		EX260-VPN1 (12) EX260-VPN1 (16)	8 bytes	-	
Pressure value / Channel status shared	Pressure value / Channel status	-	2 bytes	-	Sub module for control. Refer to <a href="#">Section 5.2</a> .
	Shared inputs	-	2 bytes	-	Sub module for copied data. 2 bytes input data for pressure value and channel status are copied.
Unit status shared	Unit status	-	1 byte	-	Sub module for control. Refer to <a href="#">Section 5.3</a> .
	Shared inputs	-	1 byte	-	Sub module for copied data. 1 byte input data for unit status are copied.

### 3.5. Configuration steps

- Select the head module according to the number of ejectors connected.
- When the head module is selected, the “Vacuum / Release” module is automatically entered in the “Vacuum / Release” slot.
- Enter the “Pressure value / Channel status” modules in “Pressure value / Channel status” slots according to the ejector required to use the pressure value and channel status (diagnosis data).
- Enter the “Unit status” module in the “Unit status” slot if required.

#### Example of a configuration

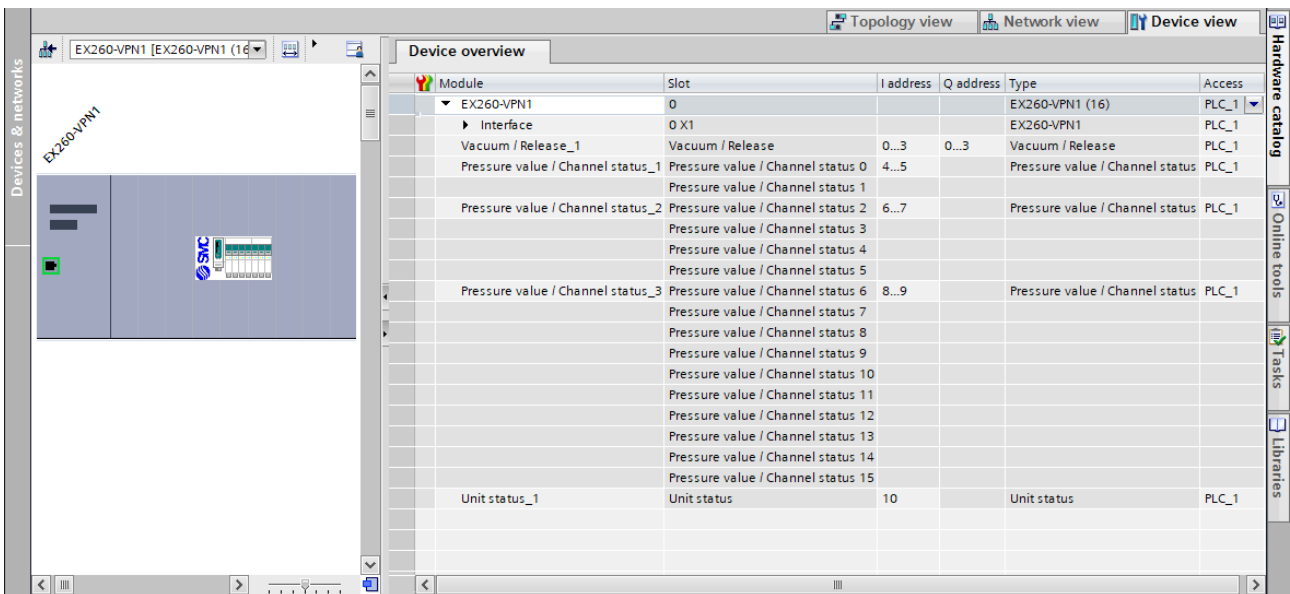

Fig. 3-1 Example of a configuration (EX260-VPN1 (16))

When configured as above, the pressure values and channel status of the ejectors on Channel 0, 2, and 6 can be used.

(The first, third and seventh ejectors counting from the SI Unit side in appearance.)

## 4. Parameter

### 4.1. Module parameters for Vacuum / Release module

The Vacuum / Release module has the following module parameters.

The following module parameters can be set individually for up to 16 ejectors from channel 0 to 15.

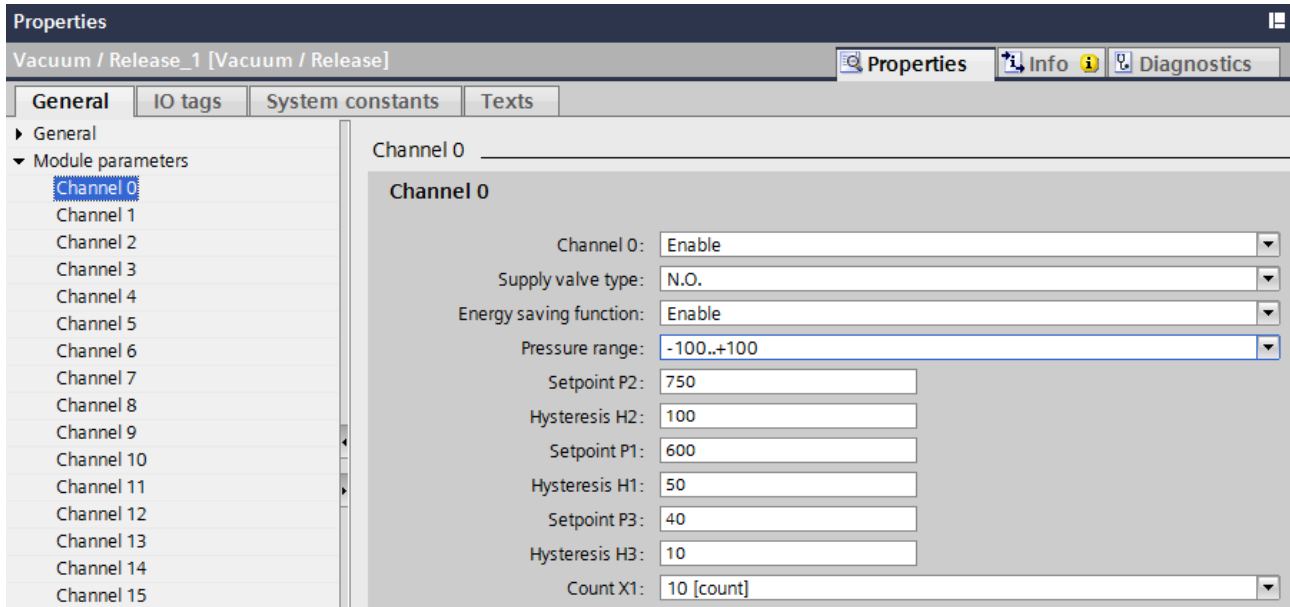

Fig. 4-1 Module parameters (EX260-VPN1 (16))

#### Caution

When parameter setting, verify that residual pressure of ejectors is exhausted and the air is released.

#### 4.1.1. Channel parameter

Table. 4-1 Channel parameter

Name	Range of values	Default	Description/Note
Channel x	Disable Enable	Enable	Set whether or not to use the pressure sensor. If set to Disable, the pressure value process data of applicable Pressure value / Channel status module is fixed at 0.

#### Caution

The Channel parameter for the channel that uses the blanking plate should be set to Disable.

#### 4.1.2. Supply valve type parameter

Table. 4-2 Supply valve type parameter

Name	Range of values	Default	Description/Note
Supply valve type	N.C. N.O.	N.O.	Set Normally Open (N.O.) or Normally Closed (N.C.) of the supply valve type. Refer to <a href="#">Section 5.1</a> .

#### Caution

The Supply valve type parameter should be set to match the actual supply valve specifications.

### 4.1.3. Energy saving function parameter

Table. 4-3 Energy saving function parameter

Name	Range of values	Default	Description/Note
Energy saving function	Disable Enable	Enable	Set ON/OFF of energy saving function.

### 4.1.4. Pressure range parameter

Table. 4-4 Pressure range parameter

Name	Range of values	Default	Description/Note
Pressure range	-100..+200 -100..+100	-100..+100	Set rated pressure range of pressure sensor. Refer to <a href="#">Section 5.2</a> .

#### Caution

The Pressure range parameter should be set to match the actual pressure sensor specifications.

### 4.1.5. Pressure parameters

Table. 4-5 Pressure parameters

Name	Range of values	Conditions		Default	Description/Note
		-100..+200	-100..+100		
Setpoint P2	21...999	P1+H2...99.9	P1+H2...99.9	750	Set the value for energy saving function and vacuum/release confirmation.
Hysteresis H2	10...988	10...P2-P1	10...P2-P1	100	
Setpoint P1	11...989	H1+1...P2-H2	H1+1...P2-H2	600	The value of P2, P1 represents negative pressure, the value of P3 represents positive pressure. Enter a value that is 10 times the pressure value [kPa]. ex) P2 = -65 [kPa] -> P2 sets 650
Hysteresis H1	10...988	10...P1-1	10...P1-1	50	
Setpoint P3	31...2000	H3+1...2000	H3+1...1000	40	Refer to <a href="#">Section 4.1.7</a> .
Hysteresis H3	10...1999	10...P3-1	10...P3-1	10	

#### Caution

- The Pressure parameters should be set so that each value meets the above conditions.
- The condition of P3 differs depending on the Pressure range parameter.

#### 4.1.6. Count parameter

Table. 4-6 Count parameter

Name	Range of values	Default	Description/Note
Count X1	Disable, 1, 2, 3... 99, 100	10	Set the valve protection function, refer to Table. 4-7. When the Energy saving function parameter is Disable, this value is invalid.

Table. 4-7 Valve protection function

Count X1	Valve protection	Description
1, 2, 3, ... 99, 100	ON	During operation of energy saving function, if the switching of vacuum generate/stop has reached "Count X1" times, stop subsequent energy saving function. Energy saving function resumes by turning PWR or PWR(V) OFF/ON or RecordData access. Refer to <a href="#">Section 6.1</a> .
Disable	OFF	The valve protection function does not operate and the energy saving function continues to operate.

#### 4.1.7. Example of ejector operation

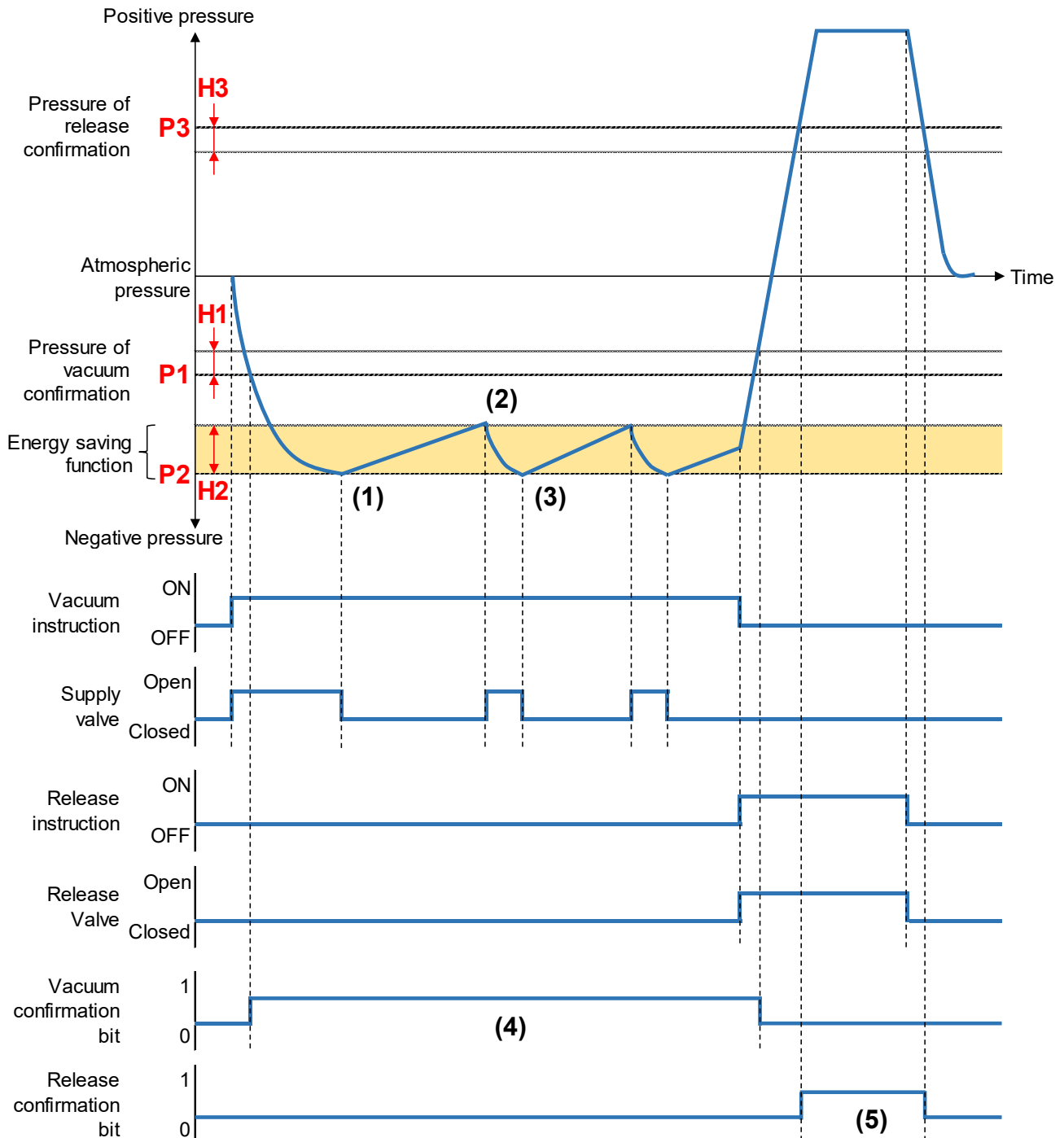

Fig. 4-2 Example of ejector operation

- (1) When the vacuum instruction is ON, the supply valve is automatically closed when the vacuum pressure reaches P2.
- (2) When the vacuum pressure drops by P2-H2, the supply valve is automatically opened again.
- (3) Repeat steps (1) and (2) unless the valve protection function is activated.
- (4) The vacuum confirmation bit is set to 1 until the vacuum pressure reaches P1 and then drops to P1-H1.
- (5) The release confirmation bit is set to 1 until the release pressure reaches P3 and then drops to P3-H3.

## 5. Process data

### 5.1. Process data on Vacuum / Release module

The Vacuum / Release module occupies 2(4) bytes of input data and 2(4) bytes of output data. The number of occupied bytes differ by the selected head module.

If there is no ejector for the applicable channel, the input data is fixed at 0, the output data is invalid. The following shows the data format.

#### 5.1.1. Input data on Vacuum / Release module

Head module: EX260-VPN1 ( 4) or ( 8)

Table. 5-1 Overview of input data on Vacuum / Release module (EX260-VPN1 ( 4) or ( 8))

Byte	Content
0	Vacuum confirmation of channel 0...7 ejector
1	Release confirmation of channel 0...7 ejector

Table. 5-2 Input data on Vacuum / Release module (EX260-VPN1 ( 4) or ( 8))

Byte	Bit	Content	Description
0	0	Vacuum confirmation of channel 0 ejector	0: No vacuum adsorption 1: During vacuum adsorption
	1	Vacuum confirmation of channel 1 ejector	
	2	Vacuum confirmation of channel 2 ejector	
	3	Vacuum confirmation of channel 3 ejector	
	4	Vacuum confirmation of channel 4 ejector	
	5	Vacuum confirmation of channel 5 ejector	
	6	Vacuum confirmation of channel 6 ejector	
	7	Vacuum confirmation of channel 7 ejector	
1	0	Release confirmation of channel 0 ejector	0: No release 1: During release
	1	Release confirmation of channel 1 ejector	
	2	Release confirmation of channel 2 ejector	
	3	Release confirmation of channel 3 ejector	
	4	Release confirmation of channel 4 ejector	
	5	Release confirmation of channel 5 ejector	
	6	Release confirmation of channel 6 ejector	
	7	Release confirmation of channel 7 ejector	

**5.1.2. Output data on Vacuum / Release module**  
**Head module: EX260-VPN1 ( 4) or ( 8)**

Table. 5-3 Overview of output data on Vacuum / Release module (EX260-VPN1 ( 4) or ( 8))

Byte	Content
0	Vacuum instruction of channel 0...7 ejector
1	Release instruction of channel 0...7 ejector

Table. 5-4 Output data on Vacuum / Release module (EX260-VPN1 ( 4) or ( 8))

Byte	Bit	Content	Description	Note
0	0	Vacuum instruction of channel 0 ejector	Supply valve type: N.O. Vacuum instruction 0: ON 1: OFF	Refer to <a href="#">Section 4.1.2.</a>
	1	Vacuum instruction of channel 1 ejector		
	2	Vacuum instruction of channel 2 ejector		
	3	Vacuum instruction of channel 3 ejector		
	4	Vacuum instruction of channel 4 ejector	Supply valve type: N.C. Vacuum instruction 0: OFF 1: ON	
	5	Vacuum instruction of channel 5 ejector		
	6	Vacuum instruction of channel 6 ejector		
	7	Vacuum instruction of channel 7 ejector		
1	0	Release instruction of channel 0 ejector	Release instruction 0: OFF 1: ON	
	1	Release instruction of channel 1 ejector		
	2	Release instruction of channel 2 ejector		
	3	Release instruction of channel 3 ejector		
	4	Release instruction of channel 4 ejector		
	5	Release instruction of channel 5 ejector		
	6	Release instruction of channel 6 ejector		
	7	Release instruction of channel 7 ejector		

**NOTE**

- If vacuum instruction ON and release instruction ON are given at the same time, the vacuum instruction takes priority and only the supply valve is opened.



**5.1.3. Input data on Vacuum / Release module**  
**Head module: EX260-VPN1 (12) or (16)**

Table. 5-5 Overview of input data on Vacuum / Release module (EX260-VPN1 (12) or (16))

Byte	Content
0	Vacuum confirmation of channel 0...7 ejector
1	Vacuum confirmation of channel 8...15 ejector
2	Release confirmation of channel 0...7 ejector
3	Release confirmation of channel 8...15 ejector

Table. 5-6 Input data on Vacuum / Release module (EX260-VPN1 (12) or (16))

Byte	Bit	Content	Description
0	0	Vacuum confirmation of channel 0 ejector	0: No vacuum adsorption 1: During vacuum adsorption
	1	Vacuum confirmation of channel 1 ejector	
	2	Vacuum confirmation of channel 2 ejector	
	3	Vacuum confirmation of channel 3 ejector	
	4	Vacuum confirmation of channel 4 ejector	
	5	Vacuum confirmation of channel 5 ejector	
	6	Vacuum confirmation of channel 6 ejector	
	7	Vacuum confirmation of channel 7 ejector	
1	0	Vacuum confirmation of channel 8 ejector	
	1	Vacuum confirmation of channel 9 ejector	
	2	Vacuum confirmation of channel 10 ejector	
	3	Vacuum confirmation of channel 11 ejector	
	4	Vacuum confirmation of channel 12 ejector	
	5	Vacuum confirmation of channel 13 ejector	
	6	Vacuum confirmation of channel 14 ejector	
	7	Vacuum confirmation of channel 15 ejector	
2	0	Release confirmation of channel 0 ejector	0: No release 1: During release
	1	Release confirmation of channel 1 ejector	
	2	Release confirmation of channel 2 ejector	
	3	Release confirmation of channel 3 ejector	
	4	Release confirmation of channel 4 ejector	
	5	Release confirmation of channel 5 ejector	
	6	Release confirmation of channel 6 ejector	
	7	Release confirmation of channel 7 ejector	
3	0	Release confirmation of channel 8 ejector	
	1	Release confirmation of channel 9 ejector	
	2	Release confirmation of channel 10 ejector	
	3	Release confirmation of channel 11 ejector	
	4	Release confirmation of channel 12 ejector	
	5	Release confirmation of channel 13 ejector	
	6	Release confirmation of channel 14 ejector	
	7	Release confirmation of channel 15 ejector	

#### 5.1.4. Output data on Vacuum / Release module Head module: EX260-VPN1 (12) or (16)

Table. 5-7 Overview of output data on Vacuum / Release module (EX260-VPN1 (12) or (16))

Byte	Content
0	Vacuum instruction of channel 0...7 ejector
1	Vacuum instruction of channel 8...15 ejector
2	Release instruction of channel 0...7 ejector
3	Release instruction of channel 8...15 ejector

Table. 5-8 Output data on Vacuum / Release module (EX260-VPN1 (12) or (16))

Byte	Bit	Content	Description	Note		
0	0	Vacuum instruction of channel 0 ejector	Supply valve type: N.O. Vacuum instruction 0: ON 1: OFF	Refer to <a href="#">Section 4.1.2.</a>		
	1	Vacuum instruction of channel 1 ejector				
	2	Vacuum instruction of channel 2 ejector				
	3	Vacuum instruction of channel 3 ejector				
	4	Vacuum instruction of channel 4 ejector				
	5	Vacuum instruction of channel 5 ejector				
	6	Vacuum instruction of channel 6 ejector				
7	Vacuum instruction of channel 7 ejector					
1	0	Vacuum instruction of channel 8 ejector			Supply valve type: N.C. Vacuum instruction 0: OFF 1: ON	
	1	Vacuum instruction of channel 9 ejector				
	2	Vacuum instruction of channel 10 ejector				
	3	Vacuum instruction of channel 11 ejector				
	4	Vacuum instruction of channel 12 ejector				
	5	Vacuum instruction of channel 13 ejector				
	6	Vacuum instruction of channel 14 ejector				
2	0	Release instruction of channel 0 ejector	Release instruction 0: OFF 1: ON			
	1	Release instruction of channel 1 ejector				
	2	Release instruction of channel 2 ejector				
	3	Release instruction of channel 3 ejector				
	4	Release instruction of channel 4 ejector				
	5	Release instruction of channel 5 ejector				
	6	Release instruction of channel 6 ejector				
7	Release instruction of channel 7 ejector					
3	0	Release instruction of channel 8 ejector				
	1	Release instruction of channel 9 ejector				
	2	Release instruction of channel 10 ejector				
	3	Release instruction of channel 11 ejector				
	4	Release instruction of channel 12 ejector				
	5	Release instruction of channel 13 ejector				
	6	Release instruction of channel 14 ejector				
7	Release instruction of channel 15 ejector					

#### NOTE

- If vacuum instruction ON and release instruction ON are given at the same time, the vacuum instruction takes priority and only the supply valve is opened.

## 5.2. Process data of Pressure value / Channel status module

The Pressure value / Channel status module occupies 2 bytes each of input data for each ejector. 12 bits are for pressure value, 4 bits are for channel status data (diagnostic data).

The following input of the ejector to which Pressure value / Channel status module is applied can be read, refer to [Section 3.5](#).

The pressure value data table differs depending on the setting of the Pressure range parameter, refer to [Section 4.1.4](#).

The following shows the data format.

Table. 5-9 Input data of Pressure value / Channel status module

Bit	15	14	13	12	11	10	9	8	7	6	5	4	3	2	1	0
	Channel status				Pressure value											

### 5.2.1. Pressure value of Pressure value / Channel status module

Table. 5-10 Pressure value (Pressure range parameter: -100..+200)

Bit 11...0	Pressure value [kPa]
000 h	0.0
001 h	0.1
...	...
7CF h	199.9
7D0 h	200.0 or more
...	unused
C18 h	-100.0 or less
C19 h	-99.9
...	...
FFE h	-0.2
FFF h	-0.1

#### NOTE

- When pressure sensor failure or disconnection, or when the Channel parameter is Disable, it is set to 000 h.
- 7D1 h...C17 h is unused.

Table. 5-11 Pressure value (Pressure range parameter: -100..+100)

Bit 11...0	Pressure value [kPa]
000 h	0.0
001 h	0.1
...	...
3E7 h	99.9
3E8 h	100.0 or more
...	unused
C18 h	-100.0 or less
C19 h	-99.9
...	...
FFE h	-0.2
FFF h	-0.1

#### NOTE

- When pressure sensor failure or disconnection, or when the Channel parameter is Disable, it is set to 000 h.
- 3E9 h...C17 h is unused.

## 5.2.2. Channel status of Pressure value / Channel status module

Table. 5-12 Channel status data of Pressure value / Channel status module

Bit	Content	Description
12	Valve-coil(s) short circuit	0: Valve coil of the applicable ejector doesn't have a short circuit. 1: Valve coil of the applicable ejector has a short circuit.
13	Pressure sensor(s) failure or disconnection	0: Pressure sensor of the applicable ejector doesn't have a failure or a disconnection. 1: Pressure sensor of the applicable ejector has a failure or a disconnection.
14	Valve protection	0: Valve protection function is not operating on the applicable ejector. 1: Valve protection function is operating on the applicable ejector.
15	Reserved	Fixed at 0.

## 5.3. Process data of Unit status module

The Unit status module occupies 1 byte of input data. The following shows the data format.

Table. 5-13 Input data of Unit status module

Bit	Content	Description
0	PWR diagnostics	0: Power supply for logic/sensors (PWR) is present. 1: Power supply for logic/sensors (PWR) is low. (< approx. 18 VDC)
1	Pressure sensor(s) short circuit	0: No pressure sensors have a short circuit. 1: At least one pressure sensor has a short circuit.
2	Valve-coil(s) short circuit	0: No valve coils have a short circuit. 1: At least one valve coil has a short circuit.
3	Pressure sensor(s) failure or disconnection	0: No pressure sensors have a failure or a disconnection. 1: At least one pressure sensor has a failure or a disconnection.
4	Valve protection	0: Valve protection function is not operating. 1: Valve protection function is operating on at least one ejector.
5	Reserved	Fixed at 0.
...	...	...
7	Reserved	Fixed at 0.

## 6. RecordData

### 6.1. User specific RecordData

The following shows User specific RecordData.

Table. 6-1 User specific RecordData

Index	Slot No.	Sub Slot No.	Access	Size	Content
0x0020	1	1	Write	1 byte	Zero clear
0x0021	1	1	Write	1 byte	Valve protection release

Table. 6-2 Description of User specific RecordData

Content	Description	Value
Zero clear	Adjust pressure value to 0 kPa at atmospheric pressure.	0: No zero clear request. 1: Zero clear request. 2: Zero clear reset request.
Valve protection release	Release of valve protection function and resumption of energy saving function, Refer to <a href="#">Section 4.1.6</a> .	0: No valve protection release request. 1: Valve protection release request.

#### NOTE

- Zero clear and valve protection release is carried out in batches for all channels.
- When using the SI Unit for the first time or when changing the parameter settings, perform zero clear with the residual pressure is exhausted and the air is released.
- Zero clear request and zero clear reset request and valve protection release request are only processed when the write value changes from 0 to 1 or 0 to 2. For this reason, write 0 once for the second and subsequent request.

## 7. LED Indication and Alarm

### 7.1. LED Indication

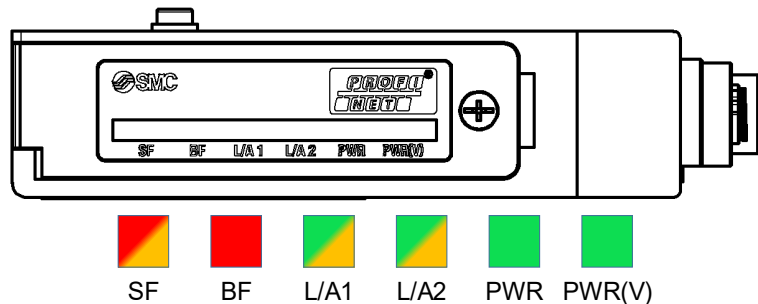

LED Indication	Content	Colour
SF	System fault	Red/Orange
BF	Bus fault	Red
L/A1	Connection status of BUS IN/Port1	Green/Orange
L/A2	Connection status of BUS OUT/Port2	Green/Orange
PWR	Power supply for logic/sensors (PWR)	Green
PWR(V)	Power supply for valves (PWR(V))	Green

Fig. 7-1 LED Indicators of the SI Unit

#### 7.1.1. SF LED and BF LED

Table. 7-1 SF LED and BF LED

SF	BF	Description
OFF	OFF	Operating normally.
Red ON	---	One of the following may have occurred. (Fault) <ul style="list-style-type: none"> <li>Valve coil has a short circuit.</li> <li>Pressure sensor has a short circuit.</li> <li>Pressure sensor has a failure or a disconnection.</li> <li>No connection between SI Unit and vacuum manifold.</li> <li>Disconnection between SI Unit and vacuum manifold.</li> </ul>
Orange ON	---	One of the following may have occurred. (Maintenance demanded) <ul style="list-style-type: none"> <li>Power supply for logic/sensors (PWR) is low. (&lt; approx. 18 VDC)</li> <li>The Supply valve type parameter does not match the actual ejector specification.</li> <li>The Pressure parameter value does not meet the conditions.</li> <li>Valve protection function is operating.</li> </ul>
---	Red ON	One of the following may have occurred. <ul style="list-style-type: none"> <li>There is no connection to the IO Controller, or the connection has an error.</li> <li>The device name is not correct.</li> <li>The IP address is not set or not correct.</li> <li>The GSD file or head module is not correct.</li> <li>The configuration is not correct.</li> </ul>
Alternately flashing (1 Hz) (SF Red SF OFF) (BF OFF ↔ BF Red)		In the process of a firmware update.
Simultaneously flashing (1 Hz) (SF Red ↔ SF OFF) (BF Red ↔ BF OFF)		The firmware update has failed or firmware error has occurred.

### 7.1.2. L/A1 LED and L/A2 LED

Table. 7-2 L/A1 LED and L/A2 LED

L/A1	L/A2	Description
Green ON	---	The SI Unit is connect to Ethernet via BUS IN/Port 1.
Orange ON	---	The SI Unit is transmitting or receiving Ethernet data via BUS IN/Port 1.
---	Green ON	The SI Unit is connect to Ethernet via BUS OUT/Port 2.
---	Orange ON	The SI Unit is transmitting or receiving Ethernet data via BUS OUT/Port 2.
OFF	OFF	The SI Unit has no connection to Ethernet.
Simultaneously flashing (1 Hz) ( L/A1 Orange ↔ L/A1 OFF L/A2 Orange ↔ L/A2 OFF )		The PROFINET function "Flash LED" (show location) is performing.

### 7.1.3. PWR LED

Table. 7-3 PWR LED

PWR	Description
Green ON	Power supply for logic/sensors (PWR) is present.
Green flashing (1 Hz)	Power supply for logic/sensors (PWR) is present but is low. (< approx. 18 VDC)
OFF	Power supply for logic/sensors (PWR) is not present.

### 7.1.4. PWR(V) LED

Table. 7-4 PWR(V) LED

PWR(V)	Description
Green ON	Power supply for valves (PWR(V)) is present.
OFF	Power supply for valves (PWR(V)) is not present.

## 7.2. Alarm

Table. 7-5 Alarm

Alarm	LED	Alarm name	Content
Fault	SF Red ON	Short circuit	Valve-coil(s) short circuit
		Short circuit (sensor)	Pressure sensor(s) short circuit
		Wire break	Pressure sensor(s) failure or disconnection
		No ejector	Vacuum manifold not connected
		Ejector disconnected	Vacuum manifold disconnected
	SF, BF simultaneously flashing	Firmware error	Firmware error
Maintenance demanded	SF Orange ON	Undervoltage logic/sensors supply (PWR)	Voltage drop of power supply for logic/sensors (PWR)
		Parameter mismatch (supply valve type)	Supply valve type parameter setting mismatch
		Parameter failure (pressure value)	Pressure parameter setting error
		Valve protection	Valve protection

Table. 7-6 Alarm content

Content	Slot No.	Sub Slot No.	Channel No.	Description
Valve-coil(s) short circuit	1	1	0...15	Valve coil of the applicable ejector has a short circuit.
Pressure sensor(s) short circuit	0	1	0	At least one pressure sensor has a short circuit.
Pressure sensor(s) failure or disconnection	1	1	0...15	Pressure sensor of the applicable ejector has a failure or a disconnection.
Vacuum manifold not connected	0	1	0	No connection between SI Unit and vacuum manifold.
Vacuum manifold disconnected	0	1	0	Disconnection between SI Unit and vacuum manifold.
Firmware error	0	1	0	The firmware update has failed or firmware error has occurred.
Voltage drop of power supply for logic/sensors (PWR)	0	1	0	Power supply for logic/sensors (PWR) is low. (< approx. 18VDC)
Supply valve type parameter mismatch	1	1	0...15	The Supply valve type parameter of the applicable ejector does not match the actual ejector specification.
Pressure parameter setting error	1	1	0...15	The Pressure parameter value of the applicable ejector does not meet the conditions.
Valve protection	1	1	0...15	Valve protection is operating on the applicable ejector.



## 8. Specification

### 8.1. Dimensions

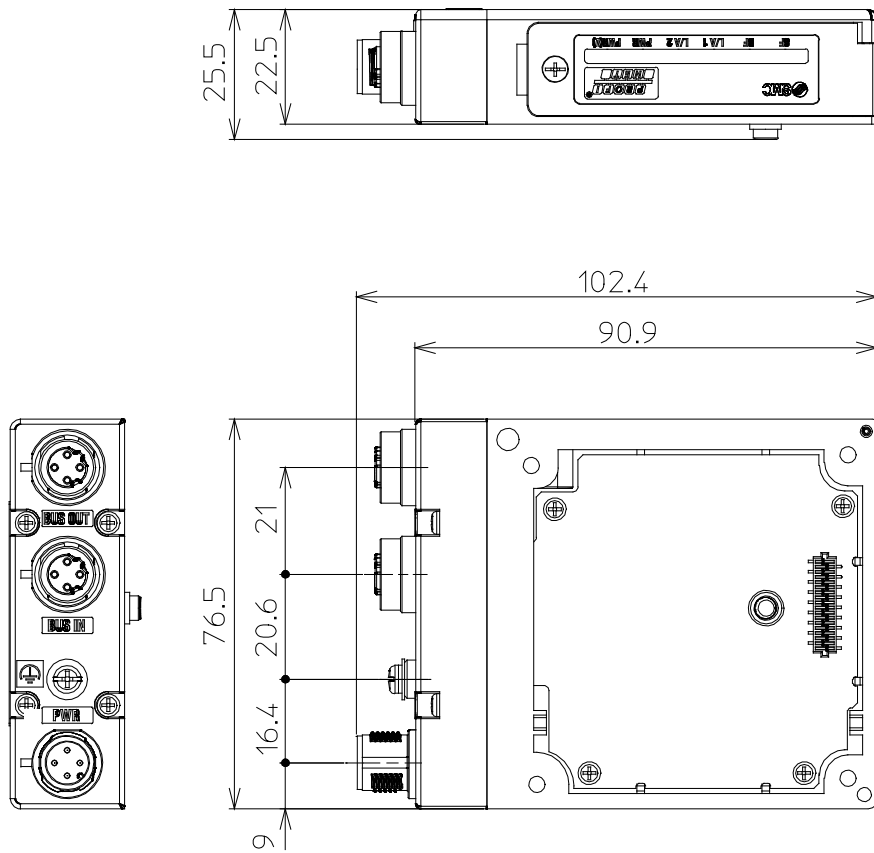

Fig.8-1 Dimensions of the SI Unit

## 8.2. Specifications

Table. 8-1 Specifications

Item	Specification	
<b>General</b>		
Dimensions (W x L x H) in mm	25.5 x 102.4 x 76.5	
Weight	150 g	
Housing materials	PBT	
Maximum number of ejectors	16	
Maximum number of sensors	16	
Applicable standard	CE/UKCA marked	
Withstand voltage	500 VAC 1 min. (between FE and all accessible terminals)	
Insulation resistance	10 Mohm or more (500 VDC between FE and all accessible terminals)	
Ambient temperature	Operation: 0 to 50 °C Storage : -20 to 60 °C	
Ambient humidity	35 to 85 %RH (non-condensing)	
<b>Electrical</b>		
Internal current consumption at 24 VDC (via PWR)	100 mA or less	
Protection against polarity reversal	Yes (PWR and PWR(V))	
PWR	Operating voltage	24 VDC +10%/-10%
	Under-voltage detection	approx. 18 VDC
PWR(V)	Operating voltage	24 VDC +10%/-5%
Galvanic isolation	Yes (between PWR and PWR(V))	
<b>Fieldbus</b>		
Bus protocol	PROFINET I/O	
Version	PROFINET Specification Version 2.3	
Conformance Class C	Yes (Only for IRT switch function)	
FSU (Fast Start Up)	Yes	
MRP (Media Redundancy Protocol)	Yes	
MRPD (Media Redundancy for Planned Duplication)	Yes	
Shared device	Yes	
NET load Class III	Yes	
Firmware update	Yes	
Vendor ID	0083 h	
Device ID	0012 h	
GSD file	GSDML-V2.3x-SMC-EX260-VPN1-xxxxxxxx.xml	

## 9. Accessories

○For fieldbus interface connector

(1) Cable with communication connector (SPEEDCON)

Part number: PCA-1446566

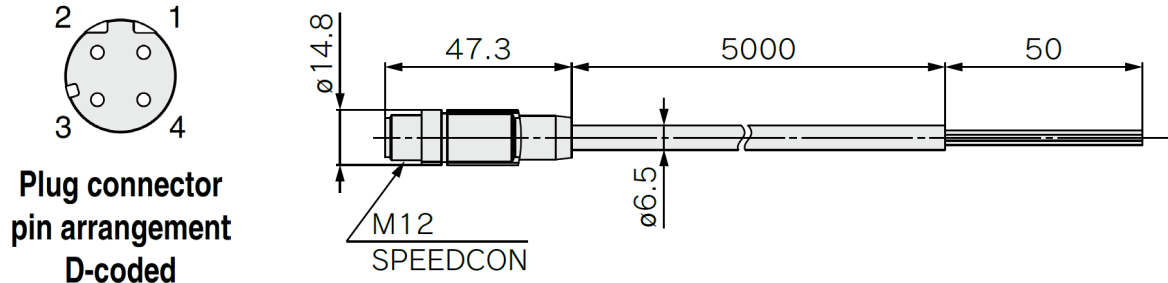

Item	Specifications
Connector	M12 Straight (SPEEDCON)
Cable length	5000 mm
Cable O.D.	φ6.5 mm
Nominal cross section	AWG22
Wire diameter (Including insulator)	1.5 mm
Min. bending radius (Fixed)	19.5 mm

Pin No.	Cable colour: Signal
1	Yellow : TD+
2	White : RD+
3	Orange: TD-
4	Blue : RD-

Fig. 9-1 PCA-1446566

(2) Field-wireable connector

Part number: PCA-1446553

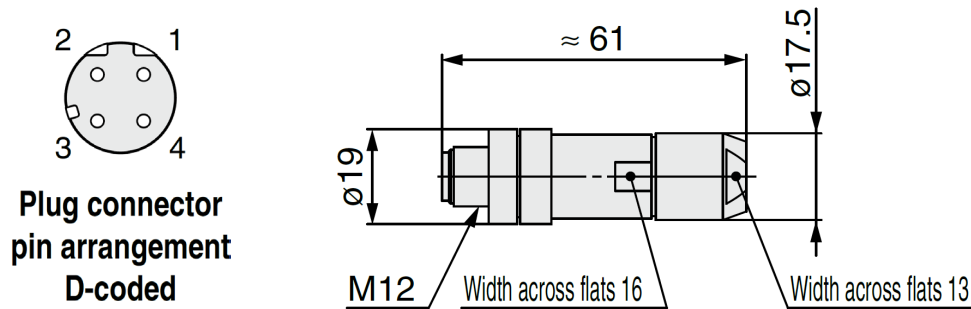

Applicable cable

Item	Specifications
Cable O.D.	φ4.0 to 8.0 mm
Electric wire cross section (Twist line)	AWG26 to 22

Pin No.	Colour on the feed holes	Cable colour	Signal
1	Orange/ White	YE=Yellow or OGWH=Orange/ White	TD+
2	Green/ White	WH=White or GNWH=Green/ White	RD+
3	Orange	OG=Orange	TD-
4	Green	BU=Blue or GN=Green	RD-

Fig. 9-2 PCA-1446553

(3) Cable with communication connector (M12 - RJ45)

Part number: EX9-AC010EN-PSRJ

Cable length (L)

01	1000 [mm]
02	2000 [mm]
03	3000 [mm]
05	5000 [mm]
10	10000 [mm]

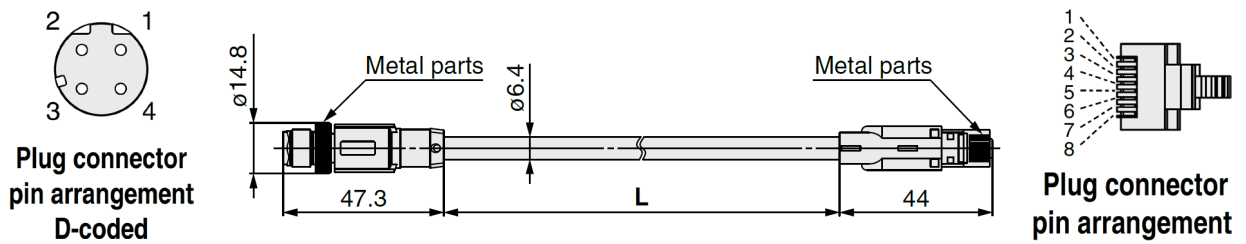

Item	Specifications
Connector	M12 Straight ⇔ RJ45
Cable O.D.	φ6.4 mm
Nominal cross section	AWG26
Min. bending radius (Fixed)	26 mm

Fig. 9-3 EX9-ACxx0EN-PSRJ

(4) Cable with communication connector (M12 - M12, Straight)

Part number: EX9-AC005EN-PSPS

Cable length (L)

005	500 [mm]
010	1000 [mm]
020	2000 [mm]
030	3000 [mm]
050	5000 [mm]
100	10000 [mm]

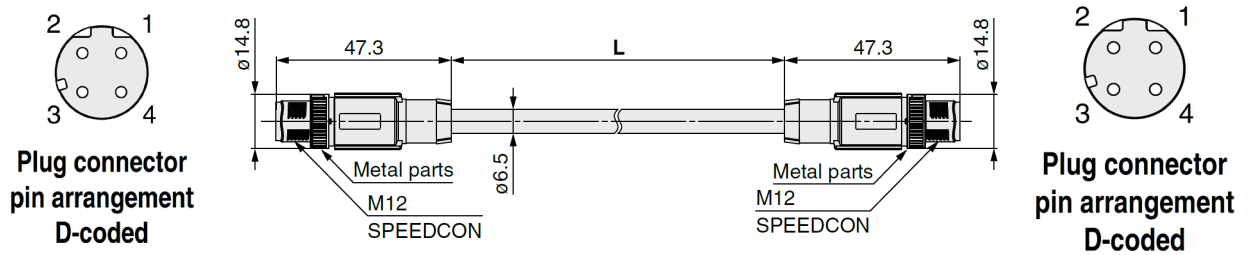

Item	Specifications
Connector	M12 Straight ↔ M12 Straight
Cable O.D.	φ6.5 mm
Nominal cross section	AWG22
Min. bending radius (Fixed)	19.5 mm

Pin No.	Cable colour: Signal
1	Yellow : TD+
2	White : RD+
3	Orange: TD-
4	Blue : RD-

Fig. 9-4 EX9-ACxxxEN-PSPS

(5) Cable with communication connector (M12 - M12, Angle)

Part number: EX9-AC005EN-PAPA

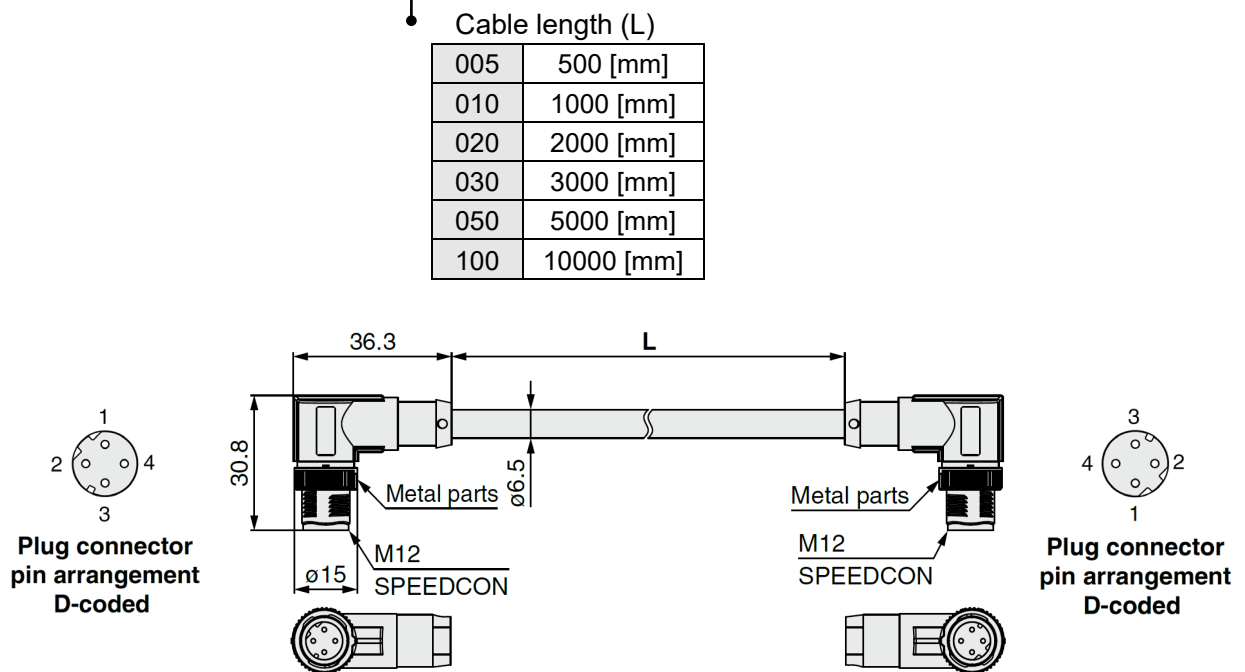

Item	Specifications
Connector	M12 Angle ↔ M12 Angle
Cable O.D.	φ6.5 mm
Nominal cross section	AWG22
Min. bending radius (Fixed)	19.5 mm

Pin No.	Cable colour: Signal
1	Yellow : TD+
2	White : RD+
3	Orange: TD-
4	Blue : RD-

Fig. 9-5 EX9-ACxxxEN-PAPA

(6) Seal cap

Part number: EX9-AWTS

This cap is used to protect the M12 connector opening when the connector is not used. When a connector is not used, the seal cap can keep the SI Unit under IP65 rated protection. (The one is included with the SI Unit as an accessory.)

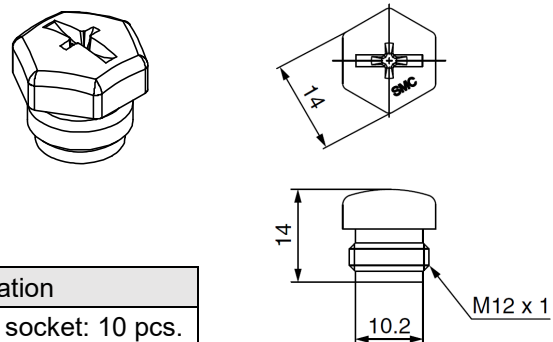

Content	Part No.	Specification
Seal cap	EX9-AWTS	For M12 connector socket: 10 pcs.

For M12 connector socket

Fig. 9-6 EX9-AWTS

- For power supply connector
- (1) Cable with power supply connector

Part number: EX500-AP010-S

Connector specifications

S	Straight
A	Angle

Cable length (L)

1	1000 [mm]
5	5000 [mm]

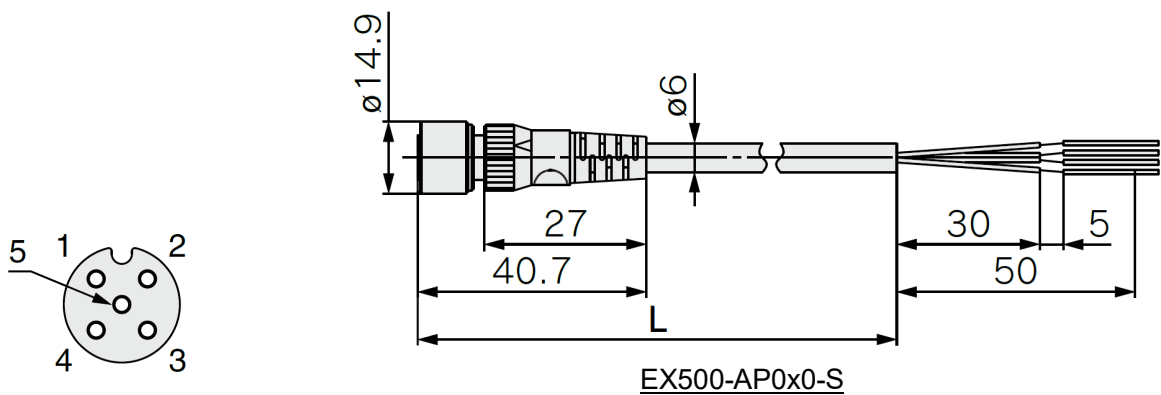

**Socket connector  
pin arrangement  
A-coded  
(Normal key)**

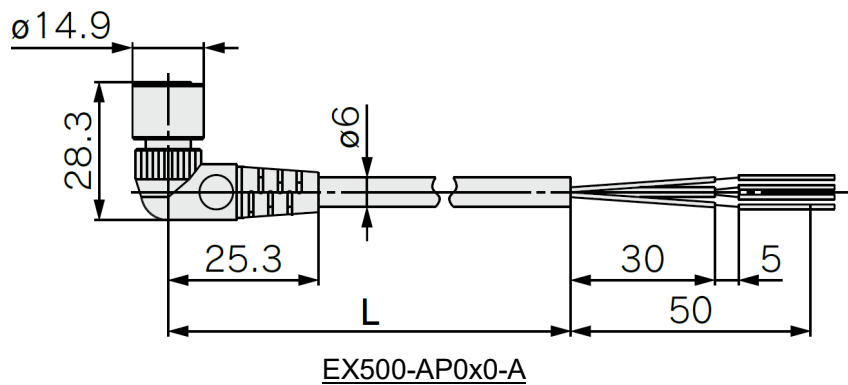

Item	Specifications
Cable O.D.	φ6 mm
Nominal cross section	AWG22
Wire diameter (Including insulator)	1.5 mm
Min. bending radius (Fixed)	40 mm

Pin No.	Cable colour: Signal
1	Brown: 24 VDC (For valves)
2	White : 0 V (For valves)
3	Blue : 24 VDC (For logic/sensors)
4	Black : 0 V (For logic/sensors)
5	Grey : Not connected

Fig. 9-7 EX500-AP0x0-x

(2) Cable with power supply connector (SPEEDCON)

Part number: PCA-140180 4

Cable length (L)

4	1500 [mm]
5	3000 [mm]
6	5000 [mm]

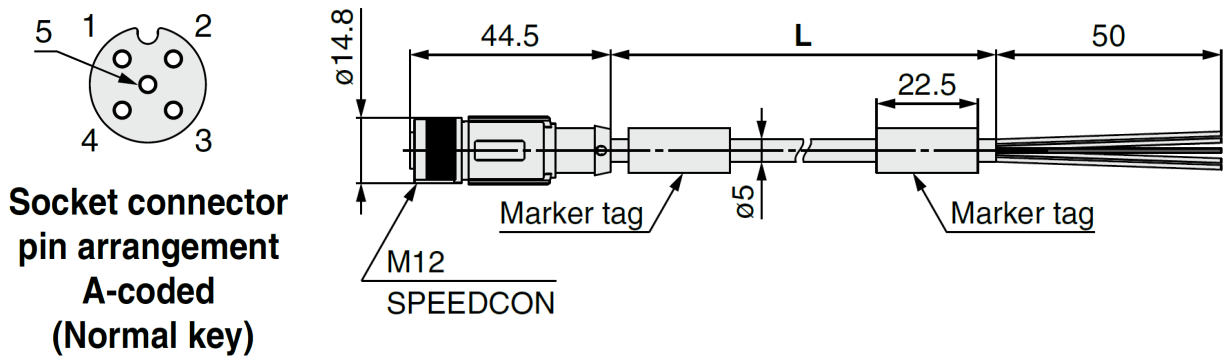

Item	Specifications
Connector	M12 Straight (SPEEDCON)
Cable O.D.	φ5 mm
Nominal cross section	AWG22
Wire diameter (Including insulator)	1.27 mm
Min. bending radius (Fixed)	21.7 mm

Pin No.	Cable colour: Signal
1	Brown: 24 VDC (For valves)
2	White : 0 V (For valves)
3	Blue : 24 VDC (For logic/sensors)
4	Black : 0 V (For logic/sensors)
5	Green/Yellow: Not connected

Fig. 9-8 PCA-140180x



## 10. Troubleshooting

The following shows the troubleshooting related the SI Unit.

Table. 10-1 Troubleshooting related fieldbus communication

No.	Content	Probable causes	Checking methods and measures
1	BF LED is ON, L/A LED is OFF	The SI Unit has no connection to Ethernet.	Check the IO Controller and cable connection.
2	BF LED is ON, L/A LED is ON	There is no connection to the IO Controller, or the connection has an error.	Check the IO Controller and cable connection. Connect to the PROFINET communication.
		The device name is not correct.	Check the settings in the configuration and the device name information of the SI Unit.
		The IP address is not set or not correct.	Check if the IP address setting is correct.
		The GSD file or head module is not correct.	Check if the GSD file and head module setting is correct.
		The configuration is not correct.	Configure the SI Unit according to the actual layout.

Table. 10-2 Troubleshooting related SF LED

No.	Content	Probable causes	Checking methods and measures
1	SF LED is red ON.	Valve coil has a short circuit.	Check the valve and connection of the applicable ejector.
		Pressure sensor has a short circuit.	Check the pressure sensor and connection.
		Pressure sensor has a failure or a disconnection.	Check the pressure sensor and connection of the applicable ejector.
		No connection or disconnection between SI Unit and vacuum manifold.	Check the connection between the SI Unit and the vacuum manifold and restart the SI Unit.
2	SF LED is orange ON.	Power supply for logic/sensors (PWR) is low. (< approx. 18 VDC)	Check the power supply voltage for logic/sensors (PWR) being supplied to the SI Unit. Supply the voltage considering the voltage drop on the wiring.
		The Supply valve type parameter does not match the actual ejector specification.	Check and modify the Supply valve type parameter setting of the applicable ejector with the residual pressure is exhausted and the air is released, then perform vacuum instruction.
		The Pressure parameter value does not meet the conditions.	Check and modify the Pressure parameter setting of the applicable ejector.
		Valve protection function is operating.	Check the vacuum pad etc. to be used with the applicable ejector. Refer to <a href="#">Section 4.1.6</a> and <a href="#">Section 6.1</a> .

Table. 10-3 Troubleshooting related SF LED and BF LED

No.	Content	Probable causes	Checking methods and measures
1	SF LED and BF LED are alternately flashing.(1Hz)	In the process of a firmware update.	---
2	SF LED and BF LED are simultaneously flashing.(1Hz)	The firmware update has failed or firmware error has occurred.	Download the latest firmware and execute firmware update.

Table. 10-4 Troubleshooting related PWR LED and PWR(V) LED

No.	Content	Probable causes	Checking methods and measures
1	PWR LED is OFF.	Incorrect wiring of power supply for logic/sensors (PWR).	Check the cable connection. Check the wiring and pin numbers.
		Power supply for logic/sensors (PWR) is not present.	Check the power supply voltage for logic/sensors (PWR) being supplied to the SI Unit. Supply the voltage considering the voltage drop on the wiring.
2	PWR LED is flashing.(1Hz)	Power supply for logic/sensors (PWR) is low. (< approx. 18 VDC)	Check the power supply voltage for logic/sensors (PWR) being supplied to the SI Unit. Supply the voltage considering the voltage drop on the wiring.
3	PWR(V) LED is OFF.	Incorrect wiring of power supply for valves (PWR(V)).	Check the cable connection. Check the wiring and pin numbers.
		Power supply for valves (PWR(V)) is not present.	Check the power supply voltage for valves (PWR(V)) being supplied to the SI Unit. Supply the voltage considering the voltage drop on the wiring.

Revision history
A: Contents revised in several places [October 2021]
B: Contents revised in several places [May 2024]

# SMC Corporation

Tel: + 81 3 5207 8249 Fax: +81 3 5298 5362

URL <https://www.smcworld.com>

---

Note: Specifications are subject to change without prior notice and any obligation on the part of the manufacturer.  
© SMC Corporation All Rights Reserved

