

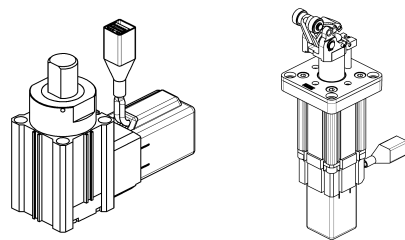

Instruction Manual Electric Stopper Cylinder Series LEB*32* / LEB*50*



The intended use of this Electrical Stopper cylinder is as a stopper for conveyor lines in response to an electrical input signal.

1 Safety Instructions

These safety instructions are intended to prevent hazardous situations and/or equipment damage. These instructions indicate the level of potential hazard with the labels of "Caution," "Warning" or "Danger." They are all important notes for safety and must be followed in addition to International Standards (ISO/IEC)⁽¹⁾, and other safety regulations.

⁽¹⁾ ISO 4414: Pneumatic fluid power - General rules relating to systems.
ISO 4413: Hydraulic fluid power - General rules relating to systems.
IEC 60204-1: Safety of machinery - Electrical equipment of machines. (Part 1: General requirements)

ISO 10218-1: Manipulating industrial robots -Safety, etc.

- Refer to the product catalogue, Drawing and Handling Precautions for SMC Products for additional information.
- Keep this manual in a safe place for future reference.

Caution	Caution indicates a hazard with a low level of risk which, if not avoided, could result in minor or moderate injury.
Warning	Warning indicates a hazard with a medium level of risk which, if not avoided, could result in death or serious injury.
Danger	Danger indicates a hazard with a high level of risk which, if not avoided, will result in death or serious injury.

Warning

- Always ensure compliance with relevant safety laws and standards.
- All work must be carried out in a safe manner by a qualified person in compliance with applicable national regulations.
- This product is class A equipment that is intended for use in an industrial environment. There may be potential difficulties in ensuring electromagnetic compatibility in other environments due to conducted as well as radiated disturbances.
- Do not disassemble, modify (including change of printed circuit board) or repair the product. An injury or product failure may result.
- Do not operate the product beyond the specification range. Fire, malfunction or equipment damage may result. Use the product only after confirming the specifications.
- When using the product as part of an interlocking system: Provide a double interlocking system, for example a mechanical system. Check the product regularly to ensure correct operation.
- Follow the instructions provided when handling the product. Failing to do so may result in product damage.
- Do not drop, hit or apply excessive shock to the product.
- Prevent any foreign matter from entering the product.
- Do not carry or swing the product by the cable.
- Do not touch the motor while in operation. The surface temperature of the motor can increase to approx. 90°C to 100°C due to operating conditions.
- If abnormal heating, smoking or fire occurs in the product, immediately turn off the power supply.
- Immediately stop operation if abnormal noise or vibration occurs.

2 Specifications

2.1 Specifications

	Model	LEB*32		LEB*50	
	Stroke [mm]	20	30		
Speed [mm/s]	80	135	67	135	67
Screw Lead [mm]	5	8	4	8	4
Actuation type		Sliding screw and cam		Sliding screw	
Operating temperature range [°C]		5 to 40			
Operating humidity range [%RH]		10 to 90			
Impact / Vibration resistance [m/s ²]		50 / 20			
Weight [g]		810	2800	2000	
Motor Size [mm]		□28	□42		
Motor type		Step motor (Servo 24 VDC)			
Encoder (angular displacement sensor)		Incremental A/B phase (resolution: 800 pulses/rotation)			
Rated voltage		24 VDC ±10%			
Power consumption [W]		29	36		
Max. momentary power consumption [W]		37	46		
Standby power consumption [W]		10	15		

Note 1) Since no magnet is mounted in this product, auto switches are not applicable.

Note 2) In regard to the mass of the transferred object and the transfer speed, conform to the operating ranges.

Note 3) After stopping the load with the electric stopper, do not apply a lateral load when the rod is retracted.

Note 4) The mounting orientation of this product is to be only vertically

upward.

Note 5) The speed and force may change depending on the cable length, load and mounting conditions. Furthermore, if the cable length exceeds 5 m then it will decrease by up to 10% for each 5 m. (At 15 m: Reduced by up to 20%).

Note 6) Impact resistance:
No malfunction occurred when the actuator was tested with a drop tester in both an axial direction and perpendicular direction to the lead screw. (The test was performed with the actuator in the initialised state).

Vibration resistance:
No malfunction occurred in a test ranging between 45 to 2000 Hz, when the actuator was tested in both an axial direction and a perpendicular direction to the lead screw. (The test was performed with the actuator in the initialised state).

Note 7) The "Power consumption" (including the controller) is for when the actuator is operating.

Note 8) The "Standby power consumption" (including the controller) is for when the actuator is stopped in the set position during the operation, except during the pushing operation.

Note 9) The "Max. momentary power consumption" (including the controller) is for when the actuator is operating. This value can be used for the selection of the power supply.

Warning

Special products (-X#, -D#) might have specifications different from those shown in this section. Contact SMC for specific drawings.

3 Name and function of individual parts

3.1 Sliding screw and cam type

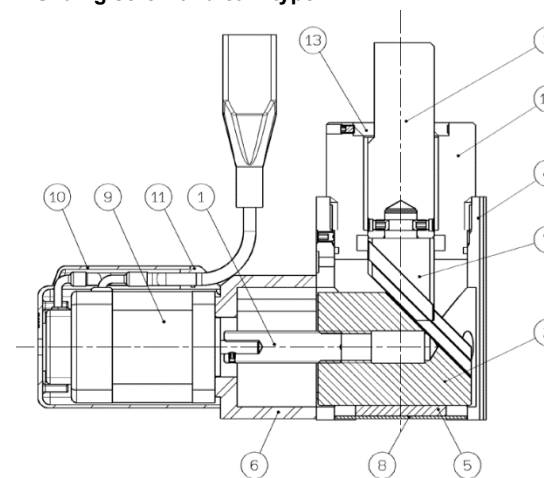

No.	Part	Material
1	Slide screw shaft	Stainless steel
2	CAM A	Stainless steel
3	Piston rod	Steel (hard chrome anodized)
4	Cylinder tube	Aluminum alloy
5	Cam holder	Stainless steel
6	Housing	Aluminum alloy
7	CAM B	Stainless steel
8	End cover	Stainless steel
9	Motor	-
10	Motor cover	Plastic
11	Grommet	Plastic
12	Rod cover Assembly	-
13	Detent guide	Steel

3.2 Sliding screw type

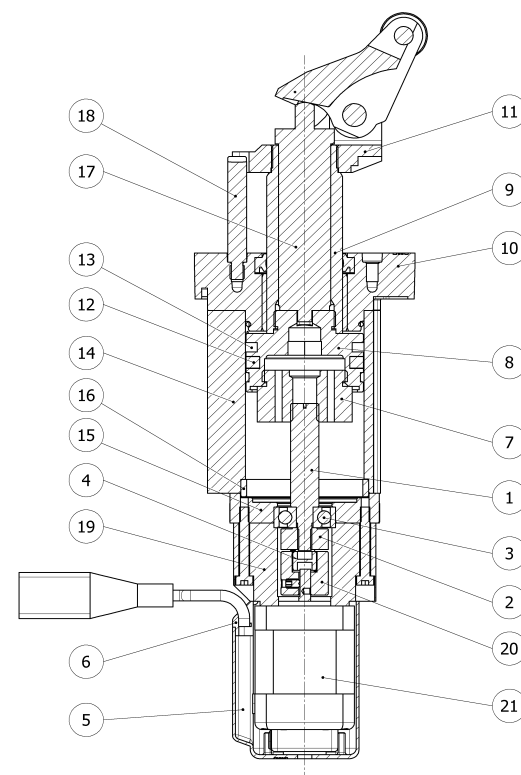

3 Name and function of individual parts (continued)

Sliding screw type

No.	Part	Material
1	Slide screw shaft	Stainless steel
2	Hub	Aluminum alloy
3	Bearing	-
4	Spider	NBR
5	Motor cover	Plastic
6	Grommet	Plastic
7	Nut	Stainless steel
8	Piston	Aluminum alloy
9	Piston rod	Steel (hard chrome anodized)
10	Rod cover Ass'y	-
11	Lever holder Assembly	-
12	Magnet	-
13	Wear ring	Resin
14	Cylinder tube	Aluminum alloy
15	Plate	Aluminum alloy
16	Guide ring	Aluminum alloy
17	Shock absorber	-
18	Guide rod	Steel (hard chrome anodized)
19	Housing	Aluminum alloy
20	Hub	Aluminum alloy
21	Motor	-

4 Installation

4.1 Installation

Warning

- Do not install the product unless the safety instructions have been read and understood.
- Do not use the product in excess of its allowable specification.
- When installing, inspecting or performing maintenance on the product, be sure to turn off the power supplies. Then, lock it so it cannot be tampered with while work is happening.
- Keep the controller and product combined as delivered for use. The product is set with parameters for shipment.
- When mounting the actuator, use all mounting holes. If all mounting holes are not used, this will not maintain the specified performance. e.g. the amount of displacement of the table will increase.
- When mounting the actuator leave a gap of 40 mm or more to allow for bending of the actuator cable.
- When mounting the actuator, use screws with adequate length and tighten them with the required torque.

Warning

- Do not apply a load in excess of the actuator specification. A product should be selected based on the maximum work load and allowable moment. If the product is used outside of the operating specification, an eccentric load applied to the guide will become excessive and have adverse effects such as creating play in the guide, reduced accuracy and reduced product life.
- Do not exceed the speed limit of the actuator specification. Select a suitable actuator by the relationship of allowable work load and speed. Noise or reduction of accuracy may occur if the actuator is operated in excess of its specification and could lead to reduced accuracy and reduced product life.
- Do not use the product in applications where excessive external force or impact force is applied.

4 Installation - continued

- Do not apply a load, impact or resistance in addition to the transferred load during return to origin. Otherwise the origin can be displaced since it is based on the detected motor torque.
- Do not operate by fixing the piston rod and moving the actuator body. An excessive load will be applied to the piston rod, leading to damage to the actuator and reduced lifetime.
- In the case of the actuator that has a servo motor (24VDC), the "motor phase detection step" is carried out by inputting the servo on signal just after the controller power is turned on.
- The "motor phase detection step" operates the table/rod to the maximum distance of the lead screw. (The motor rotates in the reverse direction if the table hits an obstacle such as the end stop damper). Take the "motor phase detection step" into consideration during the installation and operation of this actuator.

4.2 Environment

Warning

- Do not use in an environment where flammable, explosive or corrosive gases, chemicals, salt water or steam are present. This product does not have an explosion proof construction.
- Do not expose to direct sunlight. Use a suitable protective cover.
- Do not install in a location subject to vibration or impact in excess of the product's specifications.
- Do not mount in a location exposed to radiant heat that would result in temperatures in excess of the product's specifications.
- Prevent foreign particles from entering the product.
- Do not expose the product to vibration or impact.
- Use the product within the specified ambient temperature range.
- Do not expose the product to any heat radiation.

4.3 Mounting

Warning

- Observe the required tightening torque for screws. Unless stated otherwise, tighten the screws to the recommended torque for mounting the product.
- Do not make any alterations to the product. Alterations made to this product may lead to a loss of durability and damage to the product, which can lead to injury and damage to other equipment and machinery.
- Do not use the product until it has been verified that the equipment can be operated correctly. After mounting or repair, connect the power supply to the product and perform appropriate functional inspections to check it is mounted correctly. After mounting or repair, connect the power supply to the product and perform appropriate functional inspections to check it is mounted correctly.

4.4 Lubrication

Caution

- SMC products have been lubricated for life at manufacture, and do not require lubrication in service.
- If a lubricant is used in the system, refer to the catalogue on the SMC website (URL: <https://www.smcworld.com>) for details.
- The recommended grease is a special grease.
- For products with a prefix of "25A-", the recommended grease is low condensation grease.

5 Wiring

5.1 Wiring

Warning

- Adjustment, mounting or wiring changes should not be carried out before disconnecting the power supply to the product. The voltage should be checked with a tester 5 minutes after the power supply is turned off. Electric shock, malfunction and damage can result.
- Do not disassemble the cables.
- Use only specified cables.
- Do not connect or disconnect the wires, cables and connectors when the power is turned on.

Caution

- Wire the connector correctly and securely. Check the connector for polarity and do not apply any voltage to the terminals other than those specified in the Operation Manual.
- Take appropriate measures against noise. Noise in a signal line may cause malfunction. As a countermeasure separate the high voltage and low voltage cables, and shorten the wiring lengths, etc.
- Do not use the product in a place where electrical surges are generated.
- Do not route input/output wires and cables together with power or high voltage cables. The product can malfunction due to noise interference and surge voltage from power and high voltage cables close to the signal line. Route the wires of the product separately from power or high voltage cables.
- Take care that actuator movement does not catch cables.
- Operate with all wires and cables secured.
- Confirm correct insulation of wires. Poor insulation of wires, cables, connectors, terminals etc. can cause interference with other circuits. Also there is the possibility that excessive voltage or current may be applied to the product causing damage.

- Do not bend, apply tensile force, or apply force by placing heavy loads on the cables.
- Avoid bending cables at sharp angles where they enter the product.
- Avoid twisting, folding, rotating or applying an external force to the cable.
- Fix the motor cables protruding from the actuator in place before use. The motor and lock cables are not robotic type cables and can be damaged when moved.
- The actuator cables connecting the actuator and the controller are robotic type cables. But should not be placed in a flexible moving tube with a radius smaller than the specified value (50 mm minimum).

5.2 Wiring of Actuator to AC Servo Motor Driver

- Electric Stopper Cylinder

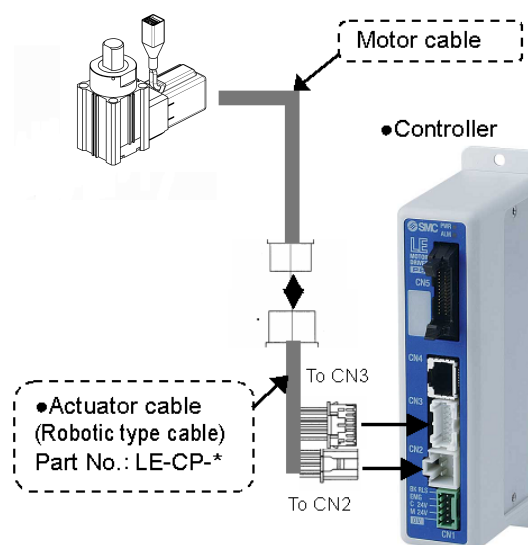

5 Wiring (continued)

5.3 Ground connection

- Provide grounding to ensure correct operation and to improve noise resistance of the product.
- The Actuator must be connected to ground to shield the actuator from electrical noise.
- Avoid shared grounding points with other devices. This product should be individually grounded using a short cable.
- The product should be connected to ground using a wire of cross-sectional area of 2 mm² minimum.
- The grounding point should be as near as possible to the actuator to keep the wire length short.

6 How to Order

Refer to the operation manual or catalogue on the SMC website (URL: <https://www.smcworld.com>) for the How to Order information.

7 Outline Dimensions (mm)

Refer to the drawings / operation manual on the SMC website (URL: <https://www.smcworld.com>) for outline dimensions.

8 Maintenance

8.1 General Maintenance

Caution

- Not following proper maintenance procedures could cause the product to malfunction and lead to equipment damage.
- If handled improperly electricity and compressed air can be dangerous.
- Maintenance of electromechanical and pneumatic systems should be performed only by qualified personnel.
- Before performing maintenance, turn off the power supply and be sure to cut off the supply pressure. Confirm that the power has been discharged and the air is released to atmosphere. The voltage should be checked with a tester 5 minutes after the power

- supply is turned off.
- After installation and maintenance, apply operating pressure and power to the equipment and perform appropriate functional and leakage tests to make sure the equipment is installed correctly.
- If any electrical or pneumatic connections are disturbed during maintenance, ensure they are reconnected correctly and safety checks are carried out as required to ensure continued compliance with applicable national regulations.
- Do not make any modification to the product.
- Do not disassemble the product, unless required by installation or maintenance instructions.
- Incorrect handling can cause an injury, damage or malfunction of the equipment and machinery, so ensure that the procedure for the task is followed.
- Always allow sufficient space around the product to complete any maintenance and inspection.

8.2 Periodical Maintenance

- Maintenance should be performed according to the table below:

Inspection	Appearance Check
Before daily operation	✓
Every six months*	✓
Every 1 million cycles*	✓

*whichever of these occurs first.

- Following any maintenance, always perform a system check. Do not use the product if any error occurs, as safety cannot be assured if caused by any un-intentional malfunction.

8.3 Visual inspection

The following items should be checked for visual appearance:

- Loose screws.
- Abnormal dirt
- Flaws / faultson cable connections.
- Vibration / noise.

9 Limitations of Use

9.1 Limited warranty and Disclaimer/Compliance Requirements

- Refer to Handling Precautions for SMC Products.

9.2 EMC Conformance

The LE series of actuators and controllers conform to EMC compatibility, if they are installed in accordance with the following instructions. These components are intended for incorporation into machinery and assemblies forming part of a larger system. The EMC compliance was achieved when the above three components were connected as shown in the diagram below. Please note that EMC conformance changes according to the configuration of the customers control panel and the relationship with other electrical equipment and wiring. Therefore conformity to the EMC directive cannot be certified for SMC components incorporated into the customer's equipment under actual operating conditions. As a result it is necessary for the customer to verify conformity to the EMC directive for the machinery and equipment as a whole.

10 Product disposal

This product should not be disposed of as municipal waste. Check your local regulations and guidelines to dispose of this product correctly, in order to reduce the impact on human health and the environment.

11 Contacts

Refer to www.smcworld.com or www.smc.eu for your local distributor / importer.

SMC Corporation

URL : <http://www.smcworld.com> (Global) <http://www.smc.eu> (Europe)
SMC Corporation, 4-14-1, Sotokanda, Chiyoda-ku, Tokyo 101-0021, Japan
Specifications are subject to change without prior notice from the manufacturer.
© 2021 SMC Corporation All Rights Reserved.
Template DKP50047-F-085M