

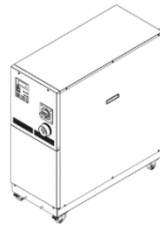

ORIGINAL INSTRUCTIONS

Instruction Manual  
Thermo-Chiller  
HRZ002/004/008/010-WS/W1S/W2S-F  
HRZ008-L/L1-F



This product used a built-in pump to circulate a liquid such as water, adjusted to a constant temperature by the refrigeration circuit. This circulating liquid cools parts of customer's machine that generate heat.

1 Safety Instructions

These safety instructions are intended to prevent hazardous situations and/or equipment damage. These instructions indicate the level of potential hazard with the labels of "Caution," "Warning" or "Danger." They are all important notes for safety and must be followed in addition to International Standards (ISO/IEC)<sup>1)</sup>, and other safety regulations.

- <sup>1)</sup>ISO 4414: Pneumatic fluid power — General rules and safety requirements for systems and their components.
- ISO 4413: Hydraulic fluid power — General rules and safety requirements for systems and their components
- IEC 60204-1: Safety of machinery - Electrical equipment of machines. Part 1: General requirements
- ISO 10218-1: Robots and robotic devices - Safety requirements for industrial robots - Part 1: Robots
- Refer to product catalogue, Operation Manual and Handling Precautions for SMC Products for additional information.
- Keep this manual in a safe place for future reference.

	<b>Caution</b>	Caution indicates a hazard with a low level of risk which, if not avoided, could result in minor or moderate injury.
	<b>Warning</b>	Warning indicates a hazard with a medium level of risk which, if not avoided, could result in death or serious injury.
	<b>Danger</b>	Danger indicates a hazard with a high level of risk which, if not avoided, will result in death or serious injury.

Warning

- Always ensure compliance with relevant safety laws and standards.
- All work must be carried out in a safe manner by a qualified person in compliance with applicable national regulations.

2 Specifications

2.1 Product Specification

HRZ002/004/008/010-WS-F

Model	HRZ002-WS-F	HRZ004-WS-F	HRZ008-WS-F	HRZ010-WS-F	
Cooling Method	Water cooled refrigeration				
Cooling capacity <sup>1)</sup> 50Hz/60Hz (kW)	2.0	4.0	8.0	10.0	
Operating temperature range (°C)	-10 to 90		-20 to 90		
Temperature stability (°C)	±0.1 <sup>3)</sup>				
Circulating fluid	Galden® HT135 <sup>4)</sup> Fluorinert™ FC-3283 <sup>4)</sup> (-20 to 40 deg C) Galden® HT200 <sup>4)</sup> Fluorinert™ FC-40 <sup>4)</sup> (20 to 90 deg C) (No intrusion of foreign body)				
Refrigerant	R410A(HFC,GWP2088)				
Quantity of refrigerant (kg)	1.5				
Pump capacity <sup>7)</sup> (MPa)	0.65 (At 20L/min)		0.72 (At 20L/min)		
Main Tank capacity <sup>9)</sup> (L)	Approx.15				
Sub Tank capacity <sup>9)</sup> (L)	Approx.16				
Circulating fluid port	Rc 3/4				
Facility water (°C / MPa)	10 to 30 / 0.3 to 0.7				
Facility water flow rate (L/min)	Rated conditions <sup>12)</sup>	4	7	14	15
	Temp. changing condition <sup>14)</sup>	10	12	15	15
Facility water port	Rc 1/2				
Power supply	3-phase 50/60Hz AC200/200 to 208V±10%				
Breaker size (A)	20				
Dimensions <sup>10)</sup> (mm)	W380×D870×H950				
Weight <sup>11)</sup> (kg)	165				
Communication	Serial RS-485 (Dsub-9pin) , Contact signal (Dsub-25pin)				

2 Specifications (continued)

HRZ002/004/008/010-W1S-F

Model	HRZ002-W1S-F	HRZ004-W1S-F	HRZ008-W1S-F	HRZ010-W1S-F	
Cooling Method	Water cooled refrigeration				
Cooling capacity <sup>1)</sup> 50Hz/60Hz (kW)	2.0	4.0	8.0	10.0	
Operating temperature range (°C)	-10 to 90		-20 to 90		
Temperature stability (°C)	±0.1 <sup>3)</sup>				
Circulating fluid	Ethylene glycol aqueous solution 60% <sup>5)</sup> (No intrusion of foreign body)				
Refrigerant	R410A(HFC,GWP2088)				
Quantity of refrigerant (kg)	1.5				
Pump capacity <sup>7)</sup> (MPa)	0.40 (At 20L/min)				
Main Tank capacity <sup>9)</sup> (L)	Approx.15				
Sub Tank capacity <sup>9)</sup> (L)	Approx.16				
Circulating fluid port	Rc 3/4				
Facility water (°C / MPa)	10 to 30 / 0.3 to 0.7				
Facility water flow rate (L/min)	Rated conditions <sup>12)</sup>	4	6	14	15
	Temp. changing condition <sup>14)</sup>	10	12	15	15
Facility water port	Rc 1/2				
Power supply	3-phase 50/60Hz AC200/200 to 208V±10%				
Breaker size (A)	20		30		
Dimensions <sup>10)</sup> (mm)	W380×D870×H950				
Weight <sup>11)</sup> (kg)	165				
Communication	Serial RS-485 (Dsub-9pin) , Contact signal (Dsub-25pin)				

HRZ002/004/008/010-W2S-F

Model	HRZ002-W2S-F	HRZ004-W2S-F	HRZ008-W2S-F	HRZ010-W2S-F
Cooling Method	Water cooled refrigeration			
Cooling capacity <sup>1)</sup> 50Hz/60Hz (kW)	2.0	4.0	8.0	10.0
Operating temperature range (°C)	-10 to 90		-20 to 90	
Temperature stability (°C)	±0.1 <sup>3)</sup>			
Circulating fluid	Pure water / DI water <sup>9)</sup> (No intrusion of foreign body)			
Refrigerant	R410A(HFC,GWP2088)			
Quantity of refrigerant (kg)	1.5			
Pump capacity <sup>7)</sup> (MPa)	0.38 (At 20L/min)			
Main Tank capacity <sup>9)</sup> (L)	Approx.15			

Model	HRZ002-W2S-F	HRZ004-W2S-F	HRZ008-W2S-F	HRZ010-W2S-F	
Sub Tank capacity <sup>9)</sup> (L)	Approx.16				
Circulating fluid port	Rc 3/4				
Facility water (°C / MPa)	10 to 30 / 0.3 to 0.7				
Facility water flow rate (L/min)	Rated conditions <sup>12)</sup>	4	7	14	15
	Temp. changing condition <sup>14)</sup>	10	12	15	15
Facility water port	Rc 1/2				
Power supply	3-phase 50/60Hz AC200/200 to 208V±10%				
Breaker size (A)	20		30		
Dimensions <sup>10)</sup> (mm)	W380×D870×H950				
Weight <sup>11)</sup> (kg)	165				
Communication	Serial RS-485 (Dsub-9pin) , Contact signal (Dsub-25pin)				

HRZ008-L/L1-F

Model	HRZ008-L-F	HRZ008-L1-F
Cooling Method	Water cooled refrigeration	
Cooling capacity <sup>2)</sup> 50Hz/60Hz (kW)	8.0 (At -10 deg C)	
Operating temperature range (°C)	-20 to 40	
Temperature stability (°C)	±0.1 <sup>3)</sup>	
Circulating fluid	Galden® HT135 <sup>4)</sup> Fluorinert™ FC-3283 <sup>4)</sup>	Ethylene glycol solution 60% <sup>5)</sup>
	(No intrusion of foreign body)	
Refrigerant	R448A(HFC,HFO,GWP1387)	
Quantity of refrigerant (kg)	2	
Pump capacity <sup>7)</sup> (MPa)	Max.0.95(At 30l/min)	Max.0.40 (At 20L/min)
Main Tank capacity <sup>9)</sup> (L)	Approx. 22	
Sub Tank capacity <sup>9)</sup> (L)	Approx. 17	
Circulating fluid port	Rc 3/4	
Facility water (°C / MPa)	10 to 25 / 0.3 to 0.7	
Facility water flow rate (L/min) <sup>13)</sup> (50Hz/60Hz)	18 / 23	
Facility water port	Rc 1/2	
Power supply	3-phase 50/60Hz AC200/200 to 208V±10%	
Main Breaker size (A)	60	
Dimensions <sup>10)</sup> (mm)	W415×D1080×H1075	
Weight <sup>11)</sup> (kg)	236	
Communication	Serial RS-485 (Dsub-9pin) , Contact signal (Dsub-25pin)	

2 Specifications (continued)

Notes:

- The capacity is derived under the conditions that the circulating fluid temp is 20 °C, the facility water temp. is 25 °C and that the circulating fluid flow rate is obtained at a specified flow rate of pump capacity.
- The capacity is derived under the conditions that the facility water temp. is 25 °C and that the circulating fluid flow rate is obtained at a specified flow rate of pump capacity. Applied to 50 / 60Hz.
- This is a system output temperature, with flow rate defined in pump capacity secured, when stabilized with no disturbance. Its upper limit may be violated if an insufficient amount of the circulating fluid is present or a disturbance to flow rate is observed.
- Galden® is a registered trademark of Solvay Solexis, and Fluorinert™ is a trademark of U.S. 3M.
- Pure ethylene glycol needs dilution with fresh water before use. Ethylene glycol with additives such as preservatives cannot be used, as it deteriorates the performance and could cause failure.
- Water quality of The Japan Refrigeration and Air Conditioning Industry Association (JRA GL-02-1994/Recirculating fluid of Cooling water system) shall be satisfied. Additives such as preservative cannot be used, as it deteriorates the performance and could cause failure.
- The capacity is derived at the Outlet of this system when the circulating fluid temp. is at 20 °C and maximum frequency operation by inverter.
- This is a minimum amount of the fluid for operation of the Thermo Chiller outfitted with internal piping and heat exchanger in this system. Circulating fluid temp.: 20 °C
- This is an auxiliary space with a main tank capacity excluded. Available for circulating fluid recovery from external piping and backup supply.
- This is the dimensions of panels, which is derived without protrusions such as a breaker handle.
- This is the mass of the system when it contains no circulating fluid.
- The required flow rate when the cooling capacity load is applied under the condition in \*1.
- Facility water temp. is 25 °C. There is required flow when adding load described on cooling capacity.
- Temporarily required flow rate when set temperature is changed under the facility water temp. 25 °C.

2.2 Product Serial Number Code

The production serial number code printed on the label indicates the month and year of production as per the following table:

Year	2020	2021	2022	...	2025	2026	2027	...
	y	Z	A	...	D	E	F	...
Jan	o	yo	Zo	Ao	...	Do	Eo	Fo
Feb	P	yP	ZP	AP	...	DP	EP	FP
Mar	Q	yQ	ZQ	AQ	...	DQ	EQ	FQ
Apr	R	yR	ZR	AR	...	DR	ER	FR
May	S	yS	ZS	AS	...	DS	ES	FS
Jun	T	yT	ZT	AT	...	DT	ET	FT
Jul	U	yU	ZU	AU	...	DU	EU	FU
Aug	V	yV	ZV	AV	...	DV	EV	FV
Sep	W	yW	ZW	AW	...	DW	EW	FW
Oct	X	yX	ZX	AX	...	DX	EX	FX
Nov	y	yy	Zy	Ay	...	Dy	Ey	Fy
Dec	Z	yZ	ZZ	AZ	...	DZ	EZ	FZ

3 How to Order

HRZ [Symbol] - W [Symbol] S [Symbol] F [Symbol]

① Cooling capacity

Symbol	Cooling capacity
002	2 kW
004	4 kW
008	8 kW
010	10 kW

② Option 2

Symbol	Contents
Nil	None
N	NPT fitting
W	SI unit only
Y*	DI control kit
Z	Circulating fluid automatic recovery

③ Circulating fluid type

Symbol	Circulating fluid type	Temperature range setting	2 kW	4 kW	8 kW	10 kW
Nil	Fluorinated fluids	-10 to 90°C	●	●	●	●
1	Ethylene glycol aqueous solution	-20 to 90°C	●	●	●	●
2	Tap water/Deionised water	10 to 60°C	●	●	●	●

④ Option 1

Symbol	Contents
Nil	None
C	Analogue communication
D	DeviceNet communication

⑤ EU F-Gas Regulation-compliant

⑥ Pump inverter and compressor inverter type

3 How to Order (continued)

HRZ 008- L [Symbol] - [Symbol] F [Symbol]

① Cooling capacity

Symbol	Cooling capacity
008	8 kW

② Temperature range settings

Symbol	Temperature range setting
L	-20 to 40°C

③ Circulating fluid type

Symbol	Contents
Nil	Fluorinated fluids
1	Ethylene glycol aqueous solution

④ Option 1

Symbol	Contents
Nil	None
C	Analogue communication
D	DeviceNet communication

⑤ Option 2

Symbol	Contents
Nil	None
N	NPT fitting
W	SI unit only
Y*	DI control kit
Z	Circulating fluid automatic recovery

⑥ EU F-Gas Regulation-compliant

4 Outline Dimensions

4.1 Dimensions of HRZ\*\*\*-WS/W1S/W2S-F

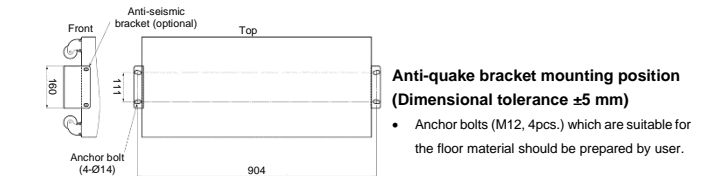
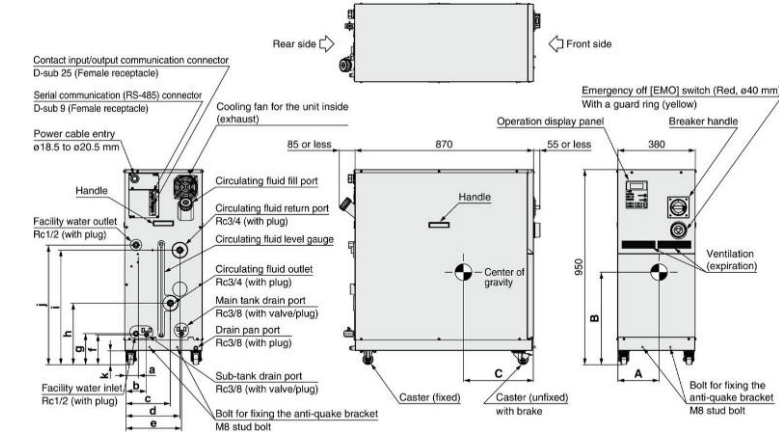

A	B	C	a	b	c	d	e	f	g	h	i	j	k	Weight (Kg)
205	439	450	57	108	224	270	278	145	151	299	558	583	68	165±5

Dimension tolerance ±10 mm  
The product weight does not include the weight of circulating fluid; the weight refers to the product in a dry state

4.2 Dimensions of HRZ008-L/L1-F

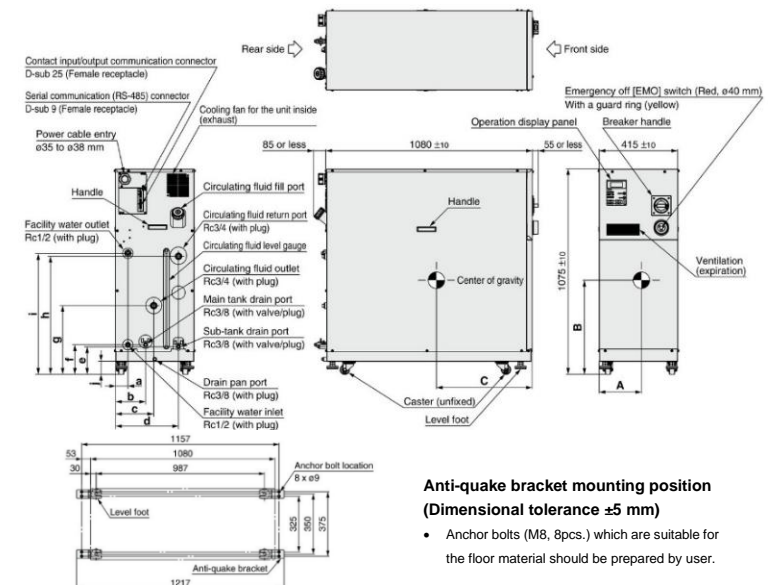

A	B	C	a	b	c	d	e	f	g	h	i	j	Weight (Kg)
215	443	427	67	160	203	332	145	156	360	619	635	68	236±5

Dimension tolerance ±10 mm  
The product weight does not include the weight of circulating fluid; the weight refers to the product in a dry state



**5 Transportation, Transfer and Moving**

**Caution**

- Do not set this system on its side during transportation. Oil in the compressor drains into the refrigerant pipe, which causes lubricant shortages, leading to damage to the compressor.
- Drain the remaining fluid out of the pipe as much as possible. The remaining fluid may spill if disregarded.
- Exercise caution not to damage the panel and piping with the forklift when transporting the system.

**5.1 Transporting with a Forklift**

**Warning**

- This system is heavy and requires a forklift to safely move it.
- For transporting with the forklift, be sure to insert the fork into a designed position. Always insert the forks all the way through. Be careful not to hit the casters and adjustable feet.
- Forklift insertion positions are on either left or right side of this system. Do not insert the from the front or the rear.
- Do not set this system on its side for transportation. Potential damage to this system carrying danger of personnel injury if disregarded.

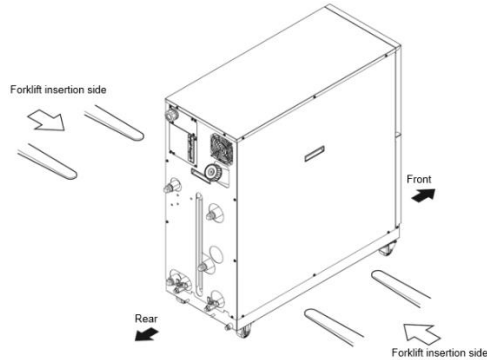

**5.2 Transporting with Caster**

**Warning**

This system is heavy, which requires assistance for this work. Exercise caution and look out for sloped surfaces such as ramps, etc.

**Caution**

Do not grab piping on the back of this system or panel handles when transporting with the casters. Potential damage to piping and panels may occur if disregarded.

**6 Installation**

**6.1 Environment**

**Warning**

- Do not use in an environment where dust, powder, corrosive gases, flammable gases, chemicals, oil, salt water or steam are present.
- Do not use in an explosive atmosphere.
- Do not expose to direct sunlight. Use a suitable protective cover.
- Do not install in a location subject to vibration or impact in excess of the product's specifications.
- Do not install in an environment that is subject to abrupt changes in temperature.
- Do not install in an environment that is subject to intense electromagnetic noise (intense electric field, intense magnetic field or surges) or strong high frequencies.
- Do not install in an environment that is subject to static electricity, or condition that discharges static electricity to the system.
- Do not install in an environment that is subject to potential lightning damage.
- Do not install where the altitude is 1000m or higher.
- Do not mount in a location exposed to radiant heat that would result in temperatures in excess of the product's specifications.
- Ambient temperature of the environment must be 10 to 35 °C in operation and 0 to 50 °C in storage.
- Humidity of the environment must be 30 to 70% in operation and 15 to 85% in storage.
- Do not install in conditions that apply an external force or weight causing system deformation.
- Do not install if there is no adequate space for maintenance in the installation site.

**6 Installation (continued)**

**6.2 Installation**

**Warning**

- The Installer / End User is responsible for carrying out a noise risk assessment on the equipment after installation and taking appropriate measures as required.

**Caution**

- Anti-seismic bracket is an optional part (except for the HRZ008-L-F and HRZ008-L1-F), which is required for the installation of this system.
- Preparations of anchor bolts suitable for floor material is your responsibility. M8-anchor bolts (8 pcs.) are required for HRZ008-L-F and HRZ008-L1-F and HRZ008-L1-F, and M12-anchor bolts (4 pcs.) for other models.

**6.2.1 Procedure to install HRZ\*\*\*-WS/W1S/W2S-F**

- Transfer system to the installation site.
- Lock the brakes on casters (2pcs. On the front).
- Using a 13-mm open and wrench, attach the anti-seismic brackets to the front and back.

**Caution**

- Drain pan port is assigned to the bottom on the back of the system. Exercise caution not to damage the drain pan port when attaching the seismic bracket.

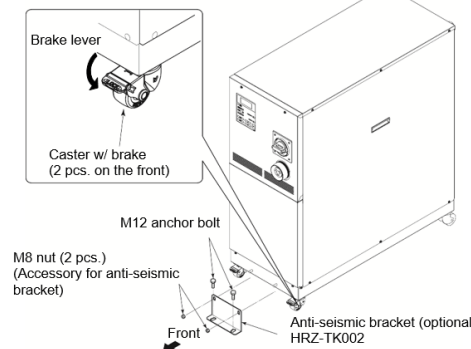
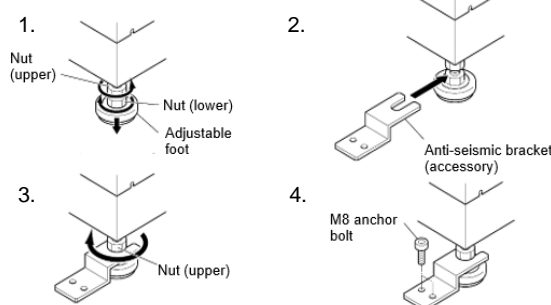

Figure 3-4 Anti-seismic Bracket Attachment

**6.2.2 Procedure to Install HRZ008-L/L1-F**

- Transfer this system to the installation site.
- Adjust the adjustable foot with a 24-mm open end wrench.
  - Level the system (using a leveller) by adjusting the adjustable feet.
  - All adjustable feet (4pcs.) must be touching the floor completely.
  - Castors need not be touching the floor.
- Attach the anti-seismic bracket to the adjustable foot and tighten the nut (upper) of the adjustable foot to lock it in.
- Secure the anti-seismic bracket with the anchor bolts. Repeat the procedures for additional brackets.



**6.3 Wiring**

**Warning**

- Only designated personnel are allowed to install wiring.
- Be sure to turn OFF the power prior to wiring to assure safety. Do not do any wiring when the system is energized.
- The system wiring requires not only a thorough connection with the designated cable but also securing to prevent loose connection. Poor connection and securing may cause electric shock, heat sports, fire or communication errors.
- Be sure to supply the power to this system according to specifications.
- Supply pure AC power. Potential malfunction may occur if a rectified AC with voltage rise (dv/dt) at zero crossing exceeds 40V /200µ sec.
- Always establish a connection to a ground for safety.
- Be sure that no ground connection is made to a water pipe, gas pipe and lighting rod.

**6 Installation (continued)**

**6.3.1 Wiring Installation**

Item	HRZ002-W'S-F	HRZ004/008-W'S-F	HRZ008-L'-F	HRZ010-W'S-F
Power cable				
Size (recommended)	10AWG x4-conductor	10AWG x4-conductor	4AWG x4-conductor	10AWG x4-conductor
Cramp Contact (recommended)	Breaker	R5, 5-5	R5, 5-5	R22-8
	Earth bar	R5, 5-8	R5, 5-8	R22-8
Torque (recommended)	Breaker	2.5 N·m	2.5 N·m	6 N·m
	Earth bar	12.5 N·m	12.5 N·m	12.5 N·m
Main breaker (This system)	20A	30A	60A	30A

**6.3.2 Procedures for wiring installation**

- Turn OFF the power breaker on the customer side (primary side), and then use the assigned procedures to perform lockout/tagout.
  - Connection of the power cable with this system must be established first. Do not connect the cable with the factory side at this point.
- Turn OFF the main breaker of this system.
- Undo the screws (2 pcs.) to remove the front panel.
- Undo the screws (2 pcs.) or press claw to remove the breaker cover.
  - Make sure the breaker is at the 'Off' position.
  - Otherwise, the removal of the front panel is not possible.

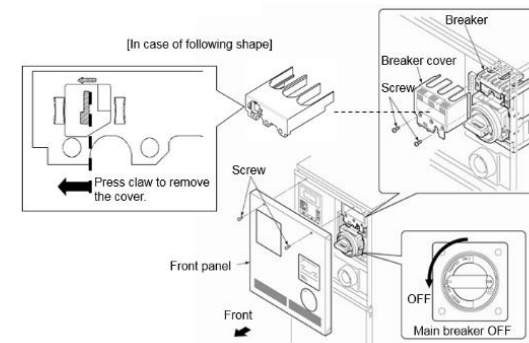

- Loosen the cap at the power cable access (strain relief) and insert the power cable.
- Connect the power cables to the breaker terminal, correct phase rotation is required.
- Connect the ground terminal (M8) of the power cable to the earth bar.

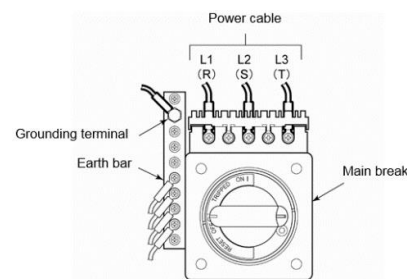

- Attach the breaker cover to the breaker.
- Attach front panel.
- Connect the power cable to the power breaker on the customer/primary side.
- Connect the communication cables with P1 and P2.

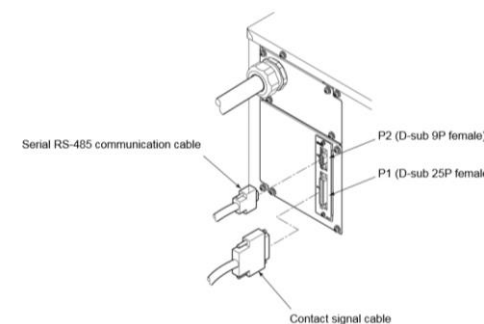

**6.4 Piping**

**Caution**

- Before connecting piping make sure to clean up chips, cutting oil, moisture, dust, and other particles. Apply air blow to the parts before using. The presence of particles, oil or moisture in the circulating fluid circuit causes insufficient cooling, system failure attributed to moisture freeze when entering the system or foaming of the circulating fluid in the tank.

**6 Installation (continued)**

- When installing piping or fittings, ensure sealant material does not enter inside the port. When using seal tape, leave 1 thread exposed on the end of the pipe/fitting.
- Tighten fittings to the specified tightening torque.
- Consider the suitability for the operating pressure and temperature of the circulating fluid and facility water, to minimise risk of pipes bursting during operation.
- Do not use corrosive materials such as aluminium and iron for fluid contact parts, like piping, as this may lead to clogging or leakage in the circulating fluid and facility water circuits, refrigerant leakage and other problems. Provide protection against corrosion when using this product.
- Always insulate external circulating piping, as this may affect cooling performance.
- When using fluorinated liquid as the circulating fluid, do not use pipe tape as leakage may occur. We recommend that you use the following sealant: SMC Part No. HRZ-S0003 (Silicone sealant)
- The total capacity of circulating fluid required by external piping should remain under the capacity of the sub tank.
- Be sure to choose a circulating fluid pipe capable of letting the fluid flow at the rated flow rate or better. See "Pump performance" defined in the operation manual, appendix 8.1.1 "System specification" for the flow rate rating.
- Have a drip pan available in case of a fluid leak.
- Do not return the circulating fluid to the unit by installing a pump in the user system.
- Make sure of the locations of ports for the circulating fluid supply, return, facility water inlet, outlet and their corresponding connections are correct.
- Do not give an impact when the piping connector section is fixed or tightened. It may damage the piping or cause leakage.
- The flow rate of the facility water is automatically adjusted depending on using conditions. The facility water outlet temperature can be up to 60°C.

**6.4.1 Pipe Diameter**

Pipe	Diameter	Recommended torque
Facility water inlet	Rc1/2	28 to 30 N·m
Facility water outlet	Rc1/2	28 to 30 N·m
Circulating fluid supply	Rc3/4	28 to 30 N·m
Circulating fluid return	Rc3/4	28 to 30 N·m
Main tank drain port	Rc3/8 (with valve)	Piping not necessary
Sub tank drain port	Rc3/8 (with valve)	Piping not necessary
Drain pan port	Rc3/8	Piping not necessary

**6.5 Circulating fluid**

**Caution**

Circulating fluids to use vary with system models. See the operation manual section 8.1.1 "System specification" for the designated fluid for a specific model

**6.5.1 Circulating fluid is 60% ethylene glycol aqueous solution**

**Caution**

- Always check the concentration of the circulating fluid
- Low concentration EG in the circulating fluid may cause system failure due to it being frozen in the system.
- High concentration EG in the circulating fluid may cause circulating pump overload, which triggers "Return Low Flow FLT"
- Potential cooling error may occur if the circulating fluid varies in concentration.

**6.5.2 Circulating fluid is fluorinated fluid**

**Caution**

Make sure of no oil, moisture, and other foreign materials contaminate the circulating fluid. Potential cooling error or system failure, due to contaminant freezes internally, may occur if disregarded.

**6.5.3 Circulating fluid is water**

**Caution**

Attention should be taken on water quality. Ensure water quality is within specified range, and other foreign materials contaminate the circulating fluid. Potential cooling error or system failure, due to contaminant freezes internally, may occur if disregarded.



**6 Installation (continued)**

**6.5.4 Supply of circulating fluid**

- Remove the circulating fluid fill cap and fill the circulating fluid until it reaches its specified temperature.
- The circulating fluid specified level is a ranged between "HIGH" and "LOW".
- Be sure to tighten the cap until it clicks after fluid supply.
- If the circulating fluid is supplied over the specified level, follow the procedure provided in the operation manual section 7.3.1 "Draining of circulating fluid out of tank" to drain excess fluid until it reaches the specified level.

Note: Level between "HIGH" and "LOW" represents liquid in normal running conditions. As you start filling up the chiller, the internal transferring pump will start pumping fluid from the Sub Tank into the Main Tank. The fluid level will start to drop, so additional fluid must be added until it is at the specified level. During initial priming of external piping, additional fluid must be added until it is at the specified level.

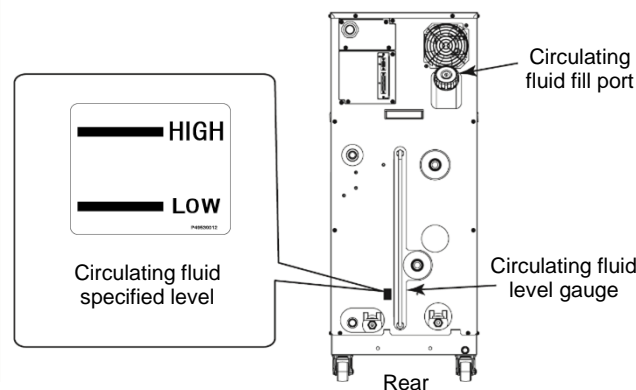

**Warning**

Circulating fluid must be supplied to be in the range between "HIGH" and "LOW". Potential overflow of hot circulating fluid may occur due to excessive volume. Total fluid volume use to fill up the system including initial priming should not exceed combined volume of Sub Tank and Main Tank. If level is below the "LOW" mark, this system will trigger an alarm.

**Caution**

When supplying the circulating fluid, make sure that the fluid inside this system has dropped to room temperature for the prevention of burn.

**Caution**

To prevent moisture, which is formed by condensation of a flowed air, from finding its way into the tank, ensure the circulating fluid at room temperature when supplying the fluid. Be sure to tighten the cap until it clicks after fluid supply. Potential circulating fluid vaporization or moisture intrusion due to condensation of flowed air may occur if disregarded.

**7 Settings**

**7.1 Operation Display Panel**

- The name of parts used in this manual are as follows:

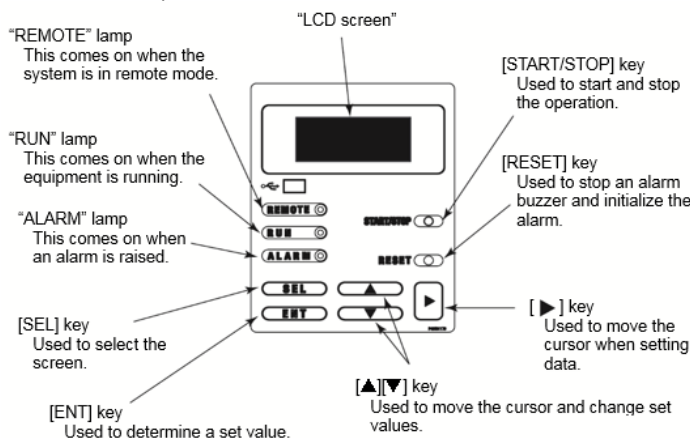

**7.2 Power On**

- Turn on the breaker handle. The model and revision number of the system should be visible on the LCD display.
- This screen remains ON for approx. 5 seconds and is automatically switched to "Status screen 1".
- The "Alarm Display screen" is displayed if error occurs in this system.

**7 Settings (continued)**

**7.3 System Startup and Shutdown**

System startup:

- Press the [START/STOP] key on the operation display panel.
- The [RUN] lamp on the operation display panel comes on, and the "System Information screen" is flashing. The screen then changes to the "Status screen 1", which initiates system operation.

System shutdown:

- Press the [START/STOP] key on the operation display panel.
- The "System Information screen" is flashing on the LCD screen, and the [RUN] lamp comes on. The compressor comes to a halt approx. 20 seconds after circulating pump stop for protection of the compressor. The screen is returned to the "Setting screen 1", which prompts the [RUN] lamp to go out.

**7.4 Different Modes and LED Screen**

There are many screens and mode that they system has. Using keys on the display panel, you can change the mode and information displayed. The LED screen can display up to four lines of text, in the following format. Please refer to the operation manual section 5.3 "Operation Screen" for the full flow chart and details of the screens.

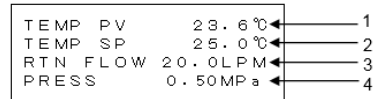

**7.4.1 Status Screens**

Cycle through screens 1 to 4 by pushing the [▼] and [▲] keys.

Item	Description
<b>Status Screen 1</b>	
TEMP PV	Discharge temperature of the circulating fluid
TEMP SP	Set value of circulating fluid discharge temperature
RTN FLOW	Return flow rate of the circulating fluid
PRESS	Discharge pressure of the circulating fluid
<b>Status Screen 2</b>	
TEMP PV	Discharge temperature of the circulating fluid
TEMP SP	Set circulating fluid temperature
<< TEMP READY >>	Displays the BAND/READY [Displayed when set value conditions are satisfied] <sup>1</sup>
TEMP BAND	Set value of BAND range <sup>1</sup>

Item	Description
<b>Status Screen 3</b>	
OFFSET	The current offset mode
OFFSET	Set offset
<b>Status Screen 4</b>	
Only displayed if the DI control kit (optional) is provided	
DI PV	Circulating fluid electric resistivity.
DI SP	Set value of circulating fluid electric resistivity.
DI ACC	Accumulated time that the solenoid valve in DI circuit is activated.
DI SV	Open/close status of solenoid valve in DI circuit.

<sup>1</sup> - See in operation manual "Appendix 8.4 BAND/READY" on offset features

**7.4.2 Alarm Display Screen**

In case of an alarm, the screen will switch to the alarm display screen. It will display the alarm code and message.

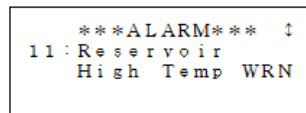

**7.4.3 Menu Screen**

Press [SEL] key when on a status screen to change it to the menu screen. Press the [▼] and [▲] keys to select the item. Press the [ENT] key to switch to the selected screen. Press [SEL] to return to the status screens.

Item	Descriptions
SETTING	Switches to the "Setting screen" with the press of the [ENT] key.
REMOTE MODE	Switches to the "Mode Selection screen" with the press of the [ENT] key.
MAINTENANCE	Switches to the "Initial Setting screen 1" with the press of the [ENT] key.

**7.4.4 Setting Screen**

Press the [▼] and [▲] keys to select the item. Press the [ENT] key to switch to the selected screen. Press [SEL] to return to the menu screen.

Item	Descriptions
CONTROL SET	Switches to the "Control Setting screen 1" with the press of the [ENT] key.
ALARM SET	Switches to the "Alarm Setting 1" with the press of the [ENT] key.
INITIAL SET	Switches to the "Initial Setting 1" with the press of the [ENT] key.

**7 Settings (continued)**

**7.4.4.1 Control setting features:**

[▲] or [▼] key is used for selecting "Item." And pressing [ENT] key enabling changing the set point. Use the [▲] or [▼] key to change the set point value. Press [SEL] to return to the setting screen.

Item	Descriptions	Setting Range	Factory Default
TEMP SP	Allows the sett of circulating fluid discharge temperature.	HRZ002-WS/W1S-F -10.0 to 90.0 °C HRZ004/008/010-WS/W1S-F -20.0 to 90.0 °C HRZ***-W2S-F 10.0 to 60.0 °C HRZ008-L/L1-F -20.0 to 40.0 °C	25.0 °C
OFFSET	Allows the setting of OFFSET value	-20.0 to 20.0 °C	0.0 °C
PUMP SP	Allows the setting of circulating fluid flow rate. (PUMP IV set to FLOW)	HRZ***-W***-F 10.0 to 40.0 LPM HRZ008-L-F 15.0 to 40.0 LPM HRZ008-L1-F 10.0 to 40.0 LPM	HRZ***-W***-F 20.0 LPM HRZ008-L-F 30.0 LPM HRZ008-L1-F 20.0 LPM
	Allows the setting of circulating fluid discharge pressure. (PUMP IV set to PRESS)	0.10 to 1.00MPa	0.10MPa
	Allows to switch to the pump frequency set screen by pressing [ENT] on this "item" (PUMP IV set to FREQ)		
DI SP	Allows the setting of circulating fluid electric resistivity.	0.0 to 2.0MΩ	0.5MΩ
DI HYS	Allows the setting of hysteresis for circulating fluid electric resistivity.	0.0 to 0.9MΩ	0.3MΩ

Pump frequency set screen:

To get to this screen, PUMP IV in Initial Settings must be set to FREQ, then go to the Control Settings and press [ENT] on PUMP SP.

Item	Descriptions	Setting Range	Factory Default
RTN FLOW	Return flow rate of circulating fluid	-	-
PRESS	Discharge pressure of circulating fluid	-	-
FREQ	Allows the setting of pump frequency.	15.0 to 60.0Hz	15.0Hz

Note: Refer to operational manual section 5.3.12 "Control Setting screen 3-2" for full details.

**7.4.4.2 Alarm setting features:**

[▲] or [▼] key is used for selecting "Item" and move to other Alarm Setting screens. And pressing the [ENT] key enabling to change the set value. Press [SEL] to return to the setting screen.

- Alarm is raised when circulating fluid temperature exceeds or falls below the set value.
  - Alarm is raised when flow rate falls below set value. Can be turned on/off.
  - Alarm is raised when DI value falls below the set value. Alarm is cancelled if the set value is 0, only if DI control kit is provided.
- See operation manual section 5.3.13-15 "Alarm Setting screen" for full details.

**7.4.4.3 Initial setting features:**

[▲] or [▼] key is used for selecting "Item" and move to other Initial Setting screens. And pressing the [ENT] key enabling to select the setting. Press [SEL] to return to the setting screen.

- Allows selection of the units for the flow rate and pressure.
- Allows selection of the offset mode.
- Options to store TEMP SP and FLOW SP values with serial communications. Also, setting for the device address for serial communication and selection of system conditions when an error occurs.
- Allow the setting of the device address for serial communication.
- Allows the selection of the control for pump operation: PUMP IV. FREQ: Pump frequency control. FLOW: Circulating fluid flow rate control. PRESS: Pump discharge pressure control.
- Allows the setting of pump discharge upper limit value. Can be turned on/off.
- Allows the selection of automatic collection stop mode. It is displayed only if the Circulating Fluid Automatic Collector is provided.
- Setting of buzzer during key input. Can be turned on/off.
- Setting of alarm buzzer. Can be turn on/off.

**7 Settings (continued)**

- Allows the selection of a function that restricts input from the operation device panel to prevent the unintended change of the setting value from the operation touch panel. Various settings dependant on communication mode.
- Allows setting of band range to TEMP PV and when "TEMP READY" is displayed on the operation display panel and Ready signal is output.
- Allows for a contact signal for a selection of alarms.
- Allows output pin no 8 to send a signal when the conditions for TEMP READY or AUTO PURGE have been completed.
- Allows setting for customised DIO signal. Can be turned on/off.
- See operation manual section 5.3.16-23 "Initial Setting screen" for full details.

**7.4.5 Remote Mode**

Allows the selection of the communication mode. Options include LOCAL, DIO REMOTE, SER REMOTE. DNET REMOTE is only available with option D. [▲] or [▼] key is used for selecting "Item" And pressing the [ENT] key enabling to select the setting. Press [SEL] to return to the menu screen. See operation manual section 5.3.24 for full details on each communication mode.

**7.4.6 Maintenance Screen**

Shows VALVE OPEN, ALARM HISTORY, RUNNING DATA, MONITOR items. AUTOPURGE is provided with the circulating fluid automatic collector option and DI ACC RESET with the DI control kit. [▲] or [▼] key is used for selecting "Item" And pressing the [ENT] key enabling to select the setting. Press [SEL] to return to the menu screen. See operation manual section 5.3.25-32 for full details on each item and following screens and options.

**8 Alarms and Troubleshooting**

**8.1 Error Message**

The following are to be performed in the event of an error in the system:

- The "ALARM" lamp comes on.
- Alarm buzzer comes on.
- The "Alarm Display screen" is displayed on the LCD screen.
- Error signal is issued through external communication.
- This system is brought to a stop forcefully according to error types.

**8.2 Troubleshooting**

The procedure for error recovery varies with alarm types:

- Alarm Code 01 to 21, 24, 25, 28\*, 29, 32: Eliminate the error cause. Press the [RESET] key on the operation

display panel or power cycle the main breaker to enable error recovery to take effect.

\*Alarm code 28 is an alarm only for HRZ010-W\*S-F.

- Alarm Code 22: Eliminate the error cause, and power cycle the main breaker to enable error recovery to take effect.
- Alarm Code 23: Automatic error recovery is implemented upon elimination of the error.
- Alarm Code 24: This is an alarm for accessories (optional). No alarm of this type is issued if the system is outfitted with no accessories.

Alarm code list and troubleshooting:

Code	Error Message	System condition	Cause	Remedies
01	Water Leak Detect FLT	Stop	The fluid is pooled at the base of this system.	Check for fluid leak.
03	RFGT High Press FLT	Stop	The pressure of the refrigerant circuit exceeded the specified value <sup>1</sup> .	Check that facility water is being supplied to this system.
04	CPRSR Overheat FLT	Stop	The temperature in the compressor was excessive <sup>1</sup> .	Check that facility water is being supplied to this system.
05	Reservoir Low Level FLT	Stop	An insufficient amount of the circulating fluid is observed in the tank.	Replenish the circulating fluid.
06	Reservoir Low Level WRN	Continued	An insufficient amount of the circulating fluid is observed in the tank.	Replenish the circulating fluid.
07	Reservoir High Level WRN	Continued	An excessive amount of the circulating fluid is observed in the tank.	Drain the circulating fluid.
08	Temp. Fuse Cutout FLT	Stop	The circulating fluid tank was raised in temperature. Thermal fuse cutout temperature: 98°C	Check the load specification. Replacement of the thermal fuse is required. Call the supplier for service.
09	Reservoir High Temp. FLT	Stop	The temperature of the circulating fluid exceeded the specified value <sup>1</sup> .	Check the load specification.
10	Return High Temp WRN	Continued	The temperature of the circulating fluid exceeded the specified value <sup>1</sup> .	Check the circulating fluid flow rate, load specification.

**8 Alarms and Troubleshooting (continued)**

Code	Error Message	System condition	Cause	Remedies
10	Return High Temp WRN	Continued	The temperature of the circulating fluid exceeded the specified value <sup>*1</sup> .	Check the circulating fluid flow rate, load specification.
11	Reservoir High Temp. WRN	Continued	The temperature of the circulating fluid exceeded your set value <sup>*1</sup> .	Reset the setting temperature.
12	Return Low Flow FLT	Stop	The flow rate of the circulating fluid falls below specified value.	• Check that the external valve is opened. • Prepare a thicker external pipe or install bypass piping.
13	Return Low Flow WRN	Continued	The flow rate of the circulating fluid falls below your set value <sup>*1</sup> .	Reset the setting flow rate.
19	FAN Motor Stop WRN	Continued	The ventilating fan came to a stop.	Check that the air vent on the back of the system is not blocked off.
20	Internal Pump Time Out WRN	Continued	The internal pump was under conditions of continuous operation over a specified time. <Specified time>10min	Check for fluid leak from circulating fluid piping in your system.
21	Controller Error FLT	Stop	An error was detected in the control system.	Contact the system supplier for request of inspection and repair.
22	Memory Data Error FLT	Stop	An error was detected in data stored in the controller of this system.	• Re-turn ON the main breaker to recover from the error. • Contact the system supplier for request of inspection and repair.
23	Communication Error 0001	Continued	An interruption of serial communication occurred in this system.	• Contact the system supplier for request of inspection and repair.
	Communication Error 8000	Continued	An interruption of serial communication occurred between this system and your system.	• Contact the system supplier for request of inspection and repair.

Code	Error Message	System condition	Cause	Remedies
24	DI Low Level WRN	Continued	The DI level of the re-circulating liquid lowered than your set value (Optional) <sup>*1</sup> .	• Lower the setting for resistivity. • Replacement of the DI filter is required
25	Pump Inverter Error FLT	Stop	An error was detected in the inverter for circulating pump.	Contact the system supplier for request of inspection and repair.
28	CPRSR INV Error FLT	Stop	An error was detected in the inverter for compressor.	Contact the system supplier for request of inspection and repair.
29	RFGT Low Press FLT	Stop	The refrigerant pressure falls below the specified value <sup>*1</sup> .	Contact the system supplier for request of inspection and repair.
32	Reservoir Low Temp. WRN	Continued	The temperature of the circulating fluid falls your set value <sup>*1</sup> .	Reset the setting temperature.

\*1 – Refer to operation manual section 6.2, Table 6-1 Troubleshooting for specified values

**9 Maintenance**

**9.1 General Maintenance**

**Warning**

- Not following proper maintenance procedures could cause the product to malfunction and lead to equipment damage.
- Maintenance of this system should be performed only by qualified personnel.
- Before performing maintenance, turn off the power supply and be sure to cut off the facility water supply.
- After installation and maintenance, perform appropriate functional and leakage tests to make sure the equipment is installed correctly.
- If any electrical connections are disturbed during maintenance, ensure they are reconnected correctly, and safety checks are carried out as required to ensure continued compliance with applicable national regulations.
- Do not make any modification to the product.
- Do not disassemble the product, unless required by installation or maintenance instructions.

**9 Maintenance (continued)**

**9.2 Water Quality Management**

**Caution**

Only designated circulating fluid is permitted to use for this system. Potential system failure and fluid leak may occur if disregarded, which results in electric shock, ground fault, and freeze. Be sure to use fresh water (tap water) compliant with water quality standards in the table below for ethylene glycol aqueous solution and facility water. See operation manual section 3.3.6 for full details.

**Caution**

If the periodic inspection finds a nonconforming substance in the facility water, clean the facility water circuit and recheck the quality of the facility water.

**9.3 Inspection and cleaning**

**Warning**

- Do not touch any electrical parts with wet hands. Keep wet hands away from electrical parts. Potential electric shock can occur if disregarded.
- Keep this system from water. Potential electric shock or fire can occur if disregarded.
- If the inspection and cleaning require the removal of the panel, be sure to re-attach the panel upon completion. Potential personal injury or electric shock may occur if operated with the panel opened or removed.

**9.3.1 Daily Inspection**

Inspection item	Inspection method	
Installation condition	Check of the condition of system installation	No heavy object is placed on this system. This system should not be subjected to external force. Temperature and humidity fall within the specified range.
Fluid leak	Check of the piping connector section	No leak of facility water and circulating fluid from the piping connector section
Fluid level	Reading of the level of the circulating fluid	Level falls within the circulating fluid specified level between "High" and "Low".
Operation display panel	Display check	Clarity of letters and numbers on the LCD display should be assured.
	Function check	[RUN] lamp is ON.
Circulating fluid temperature	Confirm the reading on the LCD screen	Temperature should be within setpoint.

Inspection item	Inspection method	
Refrigerant pressure	Reading of the refrigerant pressure gauge	Value of "HI PRESS" in "Maintenance screen 6" should be in the following range. HRZ010-W*S-F: 0.5 to 2.5 MPa HRZ008-L/L1-F: 0.5 to 2.0 MPa
Discharge pressure of circulating fluid	Confirm the reading on the LCD screen	Reading should not have deviated much from last inspection.
Circulating fluid flow rate	Confirm the reading on the LCD screen	Reading should not have deviated much from last inspection.
Operating condition	Operating condition check	No abnormal noise, vibration, odour, and smoke
Facility water	Check of the facility water	Temperature, flow rate and pressure fall within the specified range.
Circulating fluid supply port cap	Check by providing manual tightening	No looseness

**9.3.2 Quarterly Inspection**

**Warning**

Quarterly inspection requires an advance lockout/tagout of this system. See section 1.5.3 in the operation manual.

Inspection item	Inspection method	
Circulating fluid	Circulating fluid is to be drained for check.	Fluid should be free of particles, moisture <sup>*1</sup> and foreign substances.
	For ethylene glycol solution, confirm that the concentration falls within the specified range.	Recommended to replace the water.
	Facility water	Facility water quality should fall within the standards specified.
Ventilation hole and electrical parts	No particles and dust should be present.	

**Caution**

Moisture trapped in the fluorinated fluid (\*1) freezes in the heat exchanger element and piping, which may lead to system failure.

**9.4 Storage**

The following should be performed for system long-term storage.

- Drain circulating fluid.
- Drain facility water.
- Cover the system with a plastic sheet for storage.

**9 Maintenance (continued)**

**9.4.1 Draining of Circulating Fluid out of Tank**

1. Prepare the container for circulating fluid recovery at the back of this system.
2. Connect the drain hoses to the main and sub tank drain ports each. Insert the tip of the hose into the container.
  - Prepare a drain hose (Rc3/8-diameter) on your responsibility.
3. Remove the cap of the circulating fluid port.
4. Open the values of the main and sub tank drain ports to drain the circulating fluid.
5. Apply air purge from the circulating fluid return to push the circulating fluid remaining in the heat exchange back in the tank and drain it.

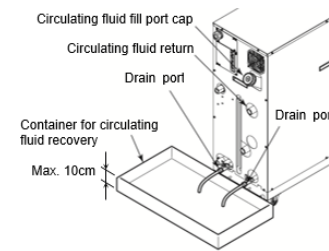

6. Upon completion of fluid draining, close the valves of the main and sub tank drain ports.
7. Add plugs to seal off ports on the rear of this system.

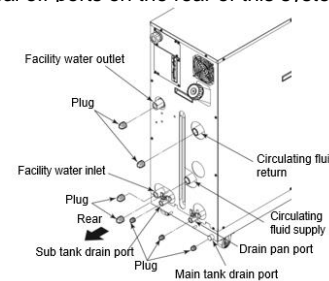

**Warning**

- If the recovered circulating fluid is contaminated by foreign substances,

- completely remove them. Do not reuse contaminated fluid.
- Potential insufficient cooling, system failure and froth in the circulating fluid may occur if disregarded.
- Recovered circulating fluid must be sealed in a container to prevent contamination from moisture or foreign substances.
- Store in a cool, dark place.
- Keep it from flame.

**Caution**

- Use the clean container for circulating fluid recovery. Reuse of the recovered circulating fluid with contaminated will cause insufficient cooling and system failure.
- Be sure to wait until the circulating fluid obtains room temperature for its draining. Potential burns and dew intrusion may occur if disregarded.

**9.4.2 Draining of Facility Water**

1. Place the drain pan underneath the piping connections on the rear of this system.
  - A 7L-capacity or bigger drain pan is required.
2. Remove facility water piping.
  - Remove the joints such as unions if present.
3. Drain the facility water using the facility water inlet port.

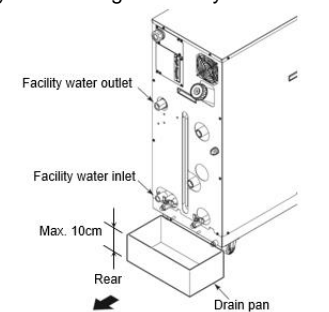

**Caution**

Be sure to drain the facility water only when it is at room temperature. Trapped fluid inside the system can still be hot. Potential burns can occur if disregarded

**9 Maintenance (continued)**

**9.5 Periodic Replacement Parts**

Replacement of consumables listed in the following table is recommended. Contact the system supplier for request of part replacements.

Part	Recommended replacement cycle
Internal pump	Every 3 years
Circulating pump	Every 3 years
Ventilation fan	Every 3 years
Inverter cooling fan	Every 3 years

\*Note: A replacement cycle may vary with your operation conditions.

**10 Limitations of Use**

**10.1 Limited Warranty and Disclaimer/Compliance Requirements**

Refer to Handling Precautions for SMC Products.

**11 Product Disposal**

This product shall not be disposed of as municipal waste. Check your local regulations and guidelines to dispose this product correctly, in order to reduce the impact on human health and the environment.

**12 Declaration of Conformity**

Below is a sample Declaration of Conformity (DoC) used in this product.

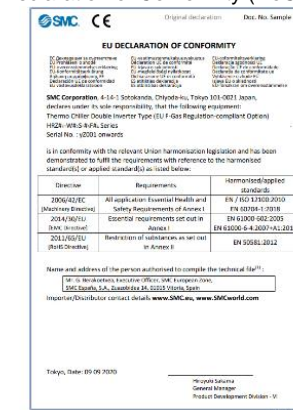

**13 Contacts**

Refer to [www.smcworld.com](http://www.smcworld.com) or [www.smc.eu](http://www.smc.eu) for your local distributor/importer.

**SMC Corporation**

URL : <https://www.smcworld.com> (Global) <https://www.smc.eu> (Europe)  
SMC Corporation, 4-14-1, Sotokanda, Chiyoda-ku, Tokyo 101-0021, Japan  
Specifications are subject to change without prior notice from the manufacturer.  
© SMC Corporation All Rights Reserved.  
Template DKP50047-F-085N