

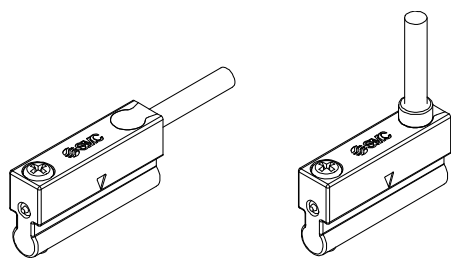

ORIGINAL INSTRUCTIONS

Instruction Manual

Analogue Auto switch and Sensor monitor  
D-MH1AD(V) and D-MH1B# series



The intended use of the auto switch is to detect and control the position of an actuator using magnetic detection.

1 Safety Instructions

These safety instructions are intended to prevent hazardous situations and/or equipment damage. These instructions indicate the level of potential hazard with the labels of "Caution," "Warning" or "Danger." They are all important notes for safety and must be followed in addition to International Standards (ISO/IEC<sup>\*)</sup>, and other safety regulations.

- \*1) ISO 4414: Pneumatic fluid power - General rules relating to systems.
- ISO 4413: Hydraulic fluid power - General rules relating to systems.
- IEC 60204-1: Safety of machinery - Electrical equipment of machines. (Part 1: General requirements)
- ISO 10218-1: Manipulating industrial robots - Safety, etc.
- Refer to product catalogue, Operation Manual and Handling Precautions for SMC Products for additional information.
- Keep this manual in a safe place for future reference.

	<b>Caution</b>	Caution indicates a hazard with a low level of risk which, if not avoided, could result in minor or moderate injury.
	<b>Warning</b>	Warning indicates a hazard with a medium level of risk which, if not avoided, could result in death or serious injury.
	<b>Danger</b>	Danger indicates a hazard with a high level of risk which, if not avoided, will result in death or serious injury.

**Warning**

- Always ensure compliance with relevant safety laws and standards.**  
All work must be carried out in a safe manner by a qualified person in compliance with applicable national regulations.
- This product is class A equipment intended for use in an industrial environment. There may be potential difficulties in ensuring electromagnetic compatibility in other environments due to conducted or radiated disturbances.
- Refer to the operation manual on the SMC website (URL: <https://www.smcworld.com>) for more Safety Instructions.
- Special products (-X) might have specifications which are different to those shown in the specifications section. Contact SMC for specific drawings.

2 Specifications

2.1 Analogue Auto Switch specifications

Model	D-MH1AD(V)
Power supply voltage	12 to 24 VDC ±10% ripple max. 10% p-p (with polarity protection)
Current consumption	10 mA or less
Output specification	Analogue voltage output: 1 to 5 V
Output impedance	Approx. 1 kΩ
Output repeatability	±20 mV <sup>*1</sup> (at 25°C)
Output temperature characteristics (at 25°C)	±80 mV (-10 to 60 °C) <sup>*2</sup>
Operating time	1 ms or less
Electrical entry method	Grommet
Impact resistance	1000 m/s <sup>2</sup>
Insulation resistance	50 MΩ or more at 500 VDC mega
Withstand voltage	1000 VAC for 1 min. (between case and cable)
Ambient temperature	-10 to 60 °C
Enclosure protection	IP67 to IEC 60529 (JISC0920)

- \*1: Single switch unit output characteristics. When the mounting orientation is uniform and there is no magnetic body or magnetic field disturbance in the surroundings. Excluding a deformation of the workpiece or wobbling of the actuator.
- \*2: Single switch unit output characteristics. The effect of fluctuations in the magnetic force of the magnet itself is excluded.
- \*: Do not apply a ferromagnetic field which exceeds 200 [mT] to the analogue auto switch. Otherwise, it may no longer operate normally.

2.2 Display Sensor Monitor specifications

Model	D-MH1B#	
Applicable sensor	D-MH1AD(V)#	
Rated pressure range	1000 to 5000 [mV]	
Display and settable range	800 to 5200 [mV]	
Display and minimum set unit	2 [mV]	
Electrical	Power supply voltage	12 to 24 VDC ±10%, ripple max. 10% p-p (with polarity protection)
	Current consumption	35 mA or less
	Temperature characteristics	±20 mV (25 °C standard)
Accuracy	Display accuracy	±20 mV ±1 digit (constant at 25 °C)
	Repeatability	±4 mV ±1 digits
Switch output	Output specification	Select from NPN or PNP open collector 2 output
	Output mode	Select from 2 setting or 3 setting mode
	Switch operation	Select from normal or reversed output
	Maximum load current	80 mA
	Max. applied voltage (NPN only)	30 VDC
	Internal voltage drop (residual voltage)	NPN: 1 V or less (80 mA load current) PNP: 1.5 V or less (80 mA load current)
	Delay time <sup>*1</sup>	1.5 ms or less (anti-chatter function: can be set from 0.00 to 5.00 sec.) (smallest settable increment: 0.01 sec.)
	Hysteresis	Variable between 0 to 2200 (initial value: 20 mV)
	Protection	Over current protection

2 Specifications (continued)

Model	D-MH1B#	
Sensor input	Input type	Voltage input: 1 to 5 VDC (input impedance: 1 MΩ)
	Number of inputs	1 input
	Connection method	Connector (e-CON)
	Protection	Over voltage protection (up to 26.4 V)
Indication	Display method	LCD
	Number of displays	1 main display and 2 sub displays
	Display colour	Main display: red or green Sub display: orange
Digital filter <sup>*2 *3</sup>		0, 10, 50, 100, 500, 1000, 5000 ms
Environmental resistance	Enclosure protection	IP40
	Withstand voltage	1000 VAC for 1 minute between terminals and housing
	Insulation resistance	50 MΩ or more between terminals and housing (with 500 VDC megger)
	Temperature range	Operation: 0 to 50 °C Storage: -10 to 60 °C (No condensation or freezing)
Humidity range	Operation and Storage: 35 to 85% RH (no condensation)	
	Product	25 g (without power/output lead wire)
Weight	Lead wire with connector	39 g (part number ZS-46-5L)

- \*1: Value without a digital filter (at 0 ms)
- \*2: It is 90% response time in relation to the step input.
- \*3: Display, switch output and analogue response time are affected.
- \*4: Any products with tiny scratches or smears on the appearance or display colour or accuracy variation which do not affect the performance are verified as conforming products.

3 Name and function of parts

3.1 Analogue auto switch

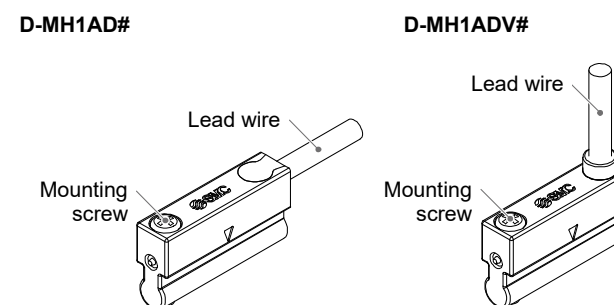

3.2 Display Sensor Monitor

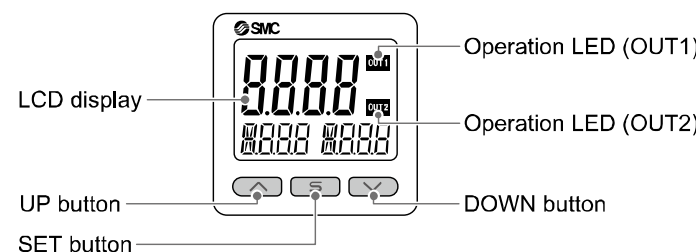

3 Name and function of parts (continued)

Item	Description
Operation LED	Displays the switch operating condition.
LCD Display	Displays the current analogue voltage, setting mode status and error code. The display method can be selected from four types at the top area of the screen: always red, always green, switching from green to red in conjunction with the output, and switching from red to green in conjunction with the output. The bottom area of the display is orange.
UP button	Use this button to select the mode and increase the ON or OFF set value.
SET button	Press this button to change the mode and confirm settings.
DOWN button	Use this button to select the mode and decrease the ON or OFF set value.

4 Installation

4.1 Installation

**Warning**

- Do not install the product unless the safety instructions have been read and understood.
- Confirm the specifications. Read the specifications carefully and use the product correctly. The product may be damaged or malfunction if it is used outside of the specification range.
- The product cannot be used for stroke length measurement. The analogue auto switch outputs a magnetic field from the cylinder magnet as an analogue value, and therefore the output is not linear to the cylinder stroke. In addition, there are individual differences in the magnetic force of

magnets. As such, the output values from magnets are different even if they are mounted to the same position on the same type actuator.

- The resolution and repeatability vary depending on the position relationship between the magnet and the sensor.
- The analogue output fluctuates due to an environment which is affected by the ambient temperature, mounting orientation (terrestrial magnetism), wobbling (mechanical factor, supply pressure fluctuation, etc.), electrical noise disturbance, magnetic body (iron screw, iron powder, etc.), or a magnetic force. It is recommended to use non-magnetic materials for magnetic bodies, screws, in the surrounding area.
- When using the product for an application where the ambient temperature or mounting orientation changes greatly, it is recommended to set the ON point under conditions that are close to the actual operating environment and set a wider ON width or hysteresis.
- Take precautions when multiple cylinders or actuators are used close together. When using two or more cylinders or actuators with a built-in magnet in close proximity to each other arranged in parallel, design so that they will maintain a separation distance of at least 40 mm (if the separation distance is specified for each cylinder/actuator series, use that value).
- Prevent reverse current from entering the product when the wire breaks down or the product is forced to operate for operation checks.
- Do not use a load which generates a surge voltage. When a surge-generating load such as a relay is driven, use a device with built in surge protection.
- The analogue auto switch output voltage will be unstable for 50 [ms] after power is supplied. The sensor monitor starts the switch output operation within approximately 200 [ms] after power is supplied. Consider these times before using the product.
- Provide a rotation stopper for the cylinder/actuator piston rod. Use a guide to stop the piston rod rotation or select an SMC product with an anti-rotation function. The output voltage may fluctuate without the rotation stopper.

## 4 Installation (continued)

### 4.2 Environment

#### Warning

- Do not use in an environment where corrosive gases, oil content, chemicals, salt water or steam are present.
- Do not use in water, or an environment where condensation occurs, or other environments where water is constantly sprayed.
- Do not use in an explosive atmosphere.
- Do not expose to direct sunlight. Use a suitable protective cover.
- Do not install in a location subject to vibration or impact in excess of the product's specifications.
- Do not mount in a location exposed to radiant heat that would result in temperatures in excess of the product specifications.
- Do not mount in a place where static electricity is a problem.
- Do not use in an area where surges are generated.
- Do not use in a welding environment.
- Do not use in an environment with cyclic temperature changes.
- Do not use in an environment subject to radiation stress.

### 4.3 Mounting precautions

- Do not drop or apply an impact to the product.
- Observe the recommended tightening torque for mounting. If tightened at a torque higher than the specified torque range the cylinder/actuator body, mounting screws, mounting brackets, and product body, etc. may be damaged. If tightened at a torque below the specified tightening torque range, the mounting position of the analogue ASW may be misaligned.
- Do not carry the product by holding the lead wire of the analogue auto switch or the display sensor monitor.
- Do not use screws other than the screws installed in the analogue auto switch for fixing.
- Adjust the mounting position of the analogue auto switch after checking the actual operating conditions.

### 4.4 Analogue auto switch mounting

- When mounting an analogue auto switch, check that the cylinder/actuator has a built-in magnet and prepare a mounting bracket corresponding to the cylinder/actuator.
- A mounting bracket is not necessary for some sensors.
- The mounting method depends on the cylinder/actuator type and tube inner diameter.
- When tightening the mounting screws, use a cross head screwdriver with #0 blade.
- The recommended mounting screw tightening torque should be 0.15 to 0.25 N·m.

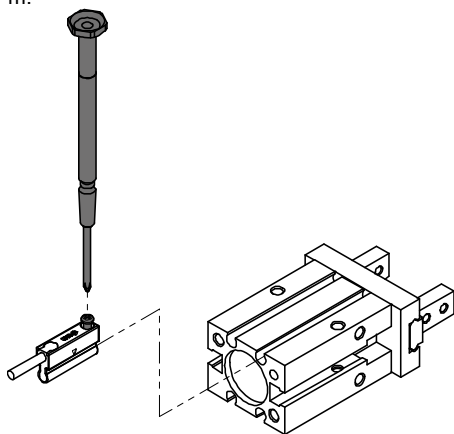

### 4.5 Display Sensor Monitor mounting

#### 4.5.1 Mounting with Bracket

- Mount the bracket to the sensor monitor using mounting self-tapping screws (nominal size 3 x 8L (2 pcs)), then set the product in the required mounting position.
- Tighten the bracket mounting screws to a torque of 0.45 to 0.55 N·m.

## 4 Installation (continued)

- Be aware that since self-tapping screws are used, they should not be mounted or removed more than once.

Bracket A (Part No. ZS-46-A1) Bracket B (Part No. ZS-46-A2)

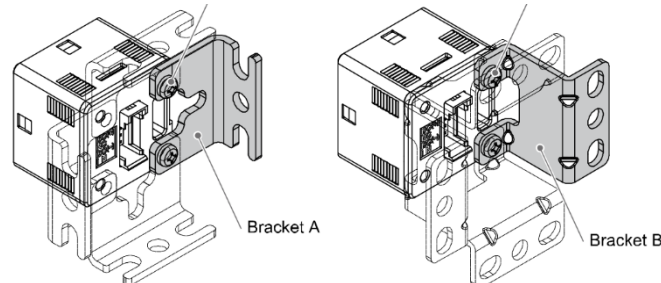

#### 4.5.2 Mounting with panel mount adapter

- Mount part (a) to the front of the product and fix it. Then insert the body into the panel until (a) comes into contact with the panel front surface.
- Next, mount part (b) to the product from the rear and insert it until (b) is in contact with the panel for fixing.
- Panel mount adapter (Part No.: ZS-46-B)
- Panel mount adapter + Front protective cover (Part No.: ZS-46-D)

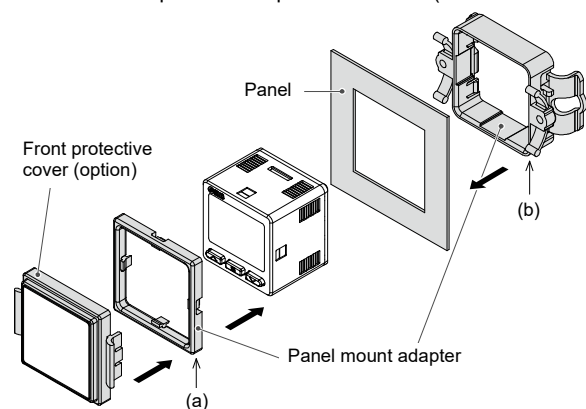

#### 4.5.3 Removal of panel mount adapter

- When removing the sensor monitor with panel mount adapter from the installation, pull it forward while opening the hooks on each side as shown. If the panel mount adapter is pulled forward with the hook caught, the product and the adapter may be damaged.

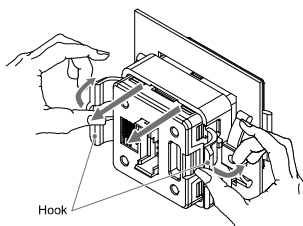

## 5 Wiring

### 5.1 Wiring

#### Caution

- Do not perform wiring while the power is on.**
- Check the insulation of the wiring.
- Use a separate route for the product wiring and any power or high voltage wiring.
- Avoid repeatedly bending or stressing lead wires. Broken lead wires can result from wiring layouts which repeatedly apply bending stress or tensile force to the lead wires.
- If a commercially available switching power supply is used, be sure to ground the frame ground (FG) terminal. If the switching power supply is connected for use, switching noise will be superimposed and it will not be able to meet the product specifications. In that case, insert a noise filter such as a line noise filter/ferrite between the switching power supplies or change the switching power supply to a series power supply.
- Make wiring as short as possible to prevent noise and surges from entering the product. Use a wiring length of less than 30 m. Also, wire the DC (-), line (blue wire) as close as possible to the power supply.

## 5 Wiring (continued)

### 5.2 Auto switch wiring

Internal circuit and wiring

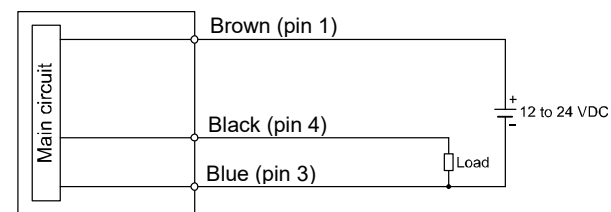

\*: The figure in the parentheses ( ) indicates the connector pin number.

Connector pin number	Wire colour	Description
1	Brown	Power supply DC (+)
3	Blue	Power supply DC (-)
4	Black	Analogue (1 to 5 V) output

#### 5.2.1 Pin assignment (pre-wired connector)

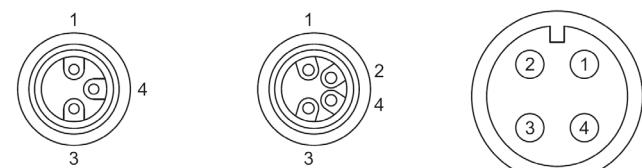

M8 3-pin connector M8 4-pin connector M12 4-pin connector

\*: A pre-wired connector cannot directly be connected to the sensor monitor.

### 5.3 Sensor Monitor wiring

NPN (2 output) specification

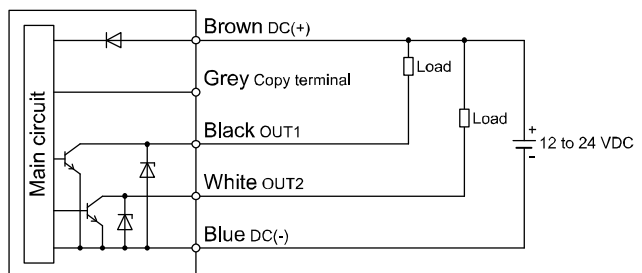

PNP (2 output) specification

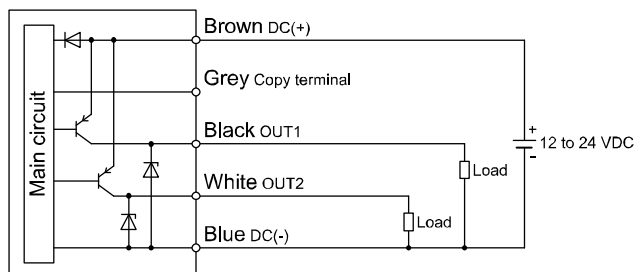

#### 5.3.1 Power and Output Connector

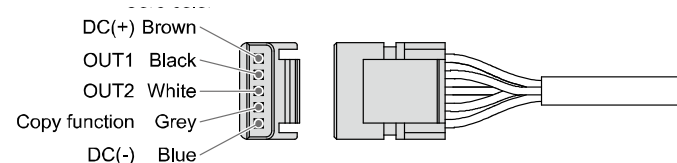

## 5 Wiring (continued)

### 5.4 Analogue auto switch to sensor monitor connection

- Prepare the analogue auto switch cable as shown. The outer sheath should be 20 mm minimum and the insulator should be present.
- Do not cut the insulator.
- The wire of the corresponding colour shown in the table is inserted into the pin number marked on the sensor connector.

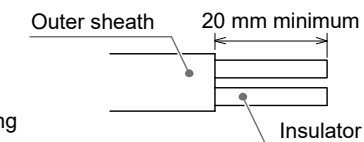

Connector marking No.	Wire colour
1	Brown (DC (+))
2	Not connected
3	Blue (DC (-))
4	Black (OUT: 1 to 5 V)

- Ensure that the above-mentioned preparation work has been performed correctly, and press part "A" by hand to make temporary connection.

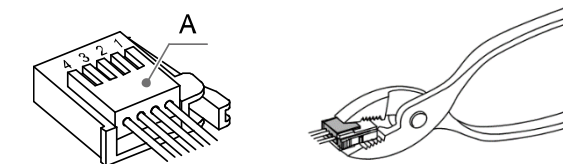

- Press part "A" centre straight in using a suitable tool, such as pliers.
- The sensor connector cannot be re-used once crimped. For a connection failure such as incorrect order of wire or incomplete insertion, use a new connector.
- If the sensor is not connected correctly, "LLL" will be displayed on the sensor monitor.

### 5.5 Compatible Sensor connectors

Connector part No.	Conductor cross sectional area (mm <sup>2</sup> )	Outside diameter (mm)	Colour of cover
ZS-28-C	0.14 to 0.2	φ0.8 to φ1.0	Red
ZS-28-CA-2	0.1 to 0.5	φ0.9 to φ1.0	

### 5.6 Connection Attachment / Detachment

- When mounting the connector, insert it straight onto the pins, holding the lever and connector body, and lock the connector by pushing the lever hook into the concave groove on the housing.
- To detach the connector, remove the hook from the groove by pressing the lever downward, and pull the connector straight out.

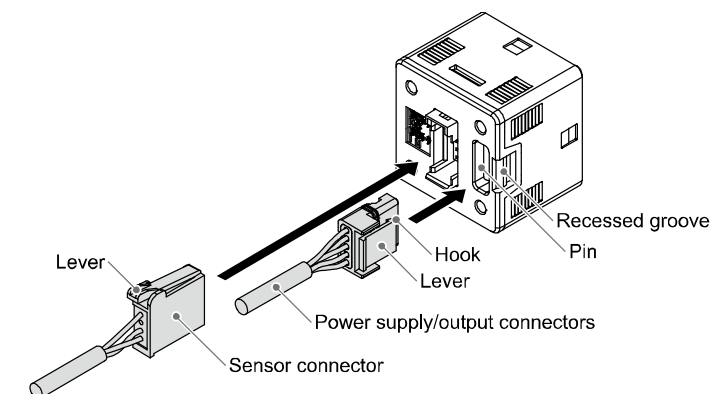



## 6 Outline of Settings

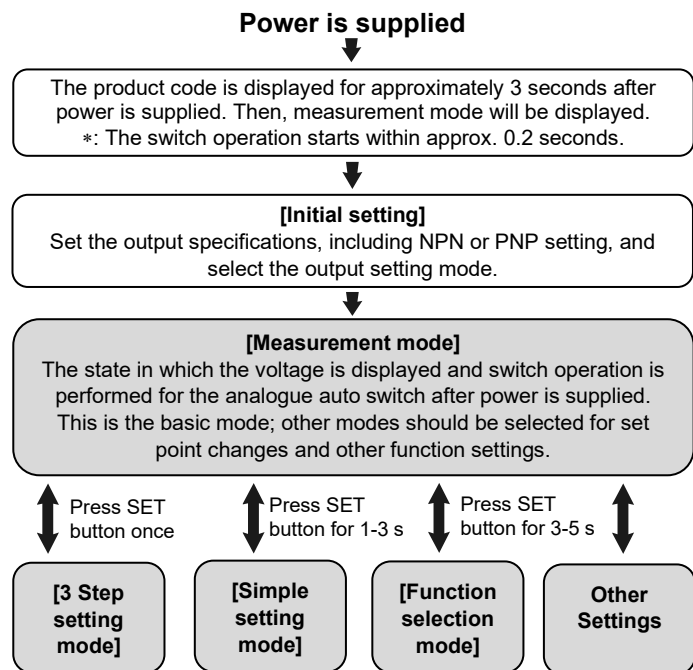

- \*: The output continues to operate during setting.
- \*: If the button is not operated for a certain period of time during setting, the display will flash (this is intended to prevent failure to complete the setting).
- \*: A setting in 3 step setting mode, simple setting mode, or function selection mode is applied to each of the modes.

## 7 3 Step Setting mode

In this mode, the set values can be input in just 3 steps. Use this mode if the product is to be used immediately, after changing

only the set values (the current voltage is displayed on the main display). In 3 step setting mode, the set values (SP1, SP2, SP3) can be changed.  
\*: The setting is possible only in 3 step setting mode. Select the item (SP1 to SP3) to change on the sub display with the UP or DOWN button. Follow the operation below.

- Press the SET button once when the item to be changed is displayed on the sub display. The set value on the sub display (right) will start flashing.

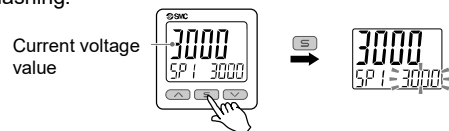

- Press the UP or DOWN button to change the set value. The UP button is to increase and the DOWN button is to decrease.
  - Press the UP button once to increase by one digit, or press and hold to continuously increase.

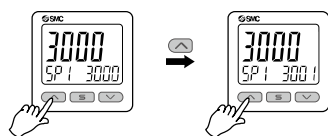

- Press the DOWN button once to decrease by one digit, or press and hold to continuously decrease.

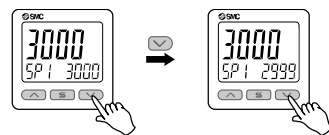

- Press the SET button to finish the setting.

The set value can be deleted by pressing the SET and DOWN buttons simultaneously for 1 second or longer.

## 8 Simple Setting mode

In simple setting mode, the set value (SP1 to SP3) and the delay time (dt) can be changed while checking the current voltage value (main display).

- Press and hold the SET button between 1 and 3 seconds in measurement mode. [SET] is displayed on the main display. Release the button while [SET] is showing on the display. The main display will show the current voltage value and the left sub display will show [SP1]. The set value will be flashing on the right sub display.



- Change the set value with the UP or DOWN button, and press the SET button to set the value. Then, the setting moves to [SP2] setting (The snap shot function can be used).

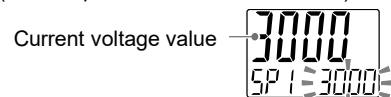

- Set [SP2] in the same manner as for [SP1]. When 3 setting mode is selected, the setting moves to the [SP3] setting after finishing the [SP2] setting. Press the SET button to set the value. Then, the setting moves to the switch output delay time.



- Press the UP or DOWN button to select the switch output delay time. Press the UP button once to increment the value or press and hold to continuously increment the value (a long press of the button increases the increment). Settable range: 0.00 [sec.] to 5.00 [sec.] (0.01 [sec.] increment).

- Press the SET button to set the value and the setting returns to the [SP1] setting again. Press the SET button for 2 seconds or longer in

one of the setting screens to complete the setting and return to measurement mode.

- \*: Each of the selected items (1) to (4) is enabled after the SET button is pressed.

## 9 Function Selection mode

In measurement mode, press the SET button between 3 and 5 seconds, to display [F 0]. Select to display the function to be changed [F##]. Press and hold the SET button for 2 seconds or longer in function selection mode to return to measurement mode.

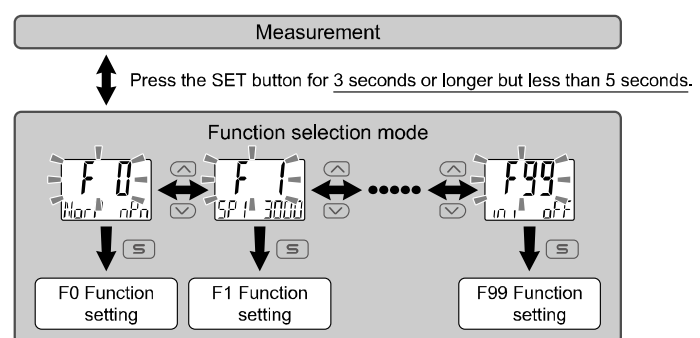

### 9.1 Default function settings

The default settings are as follows. If no problem is caused by this setting, keep the settings. To change a setting, enter function selection mode.

- [F 0] Switch output specification switchover / setting mode function

Item	Default setting
NPN or PNP output	NPN *
N.O. or N.C. output	N.O.
Analogue display inversion	OFF
Output setting mode	3 setting mode

- \*: Depends on the model number.

## 9 Function Selection mode (continued)

- [F 1] Setting of SP1

Item	Explanation	Default
Output point (SP1)	Set the analogue value to switch output.	---- (Not set)
ON width (W 1)	Set the ON range to the switch output.	50
Hysteresis (H 1)	Set an appropriate hysteresis to prevent chattering.	20
Delay time (dt)	Select the delay time of the switch output. *: A common setting for SP1 to SP3.	0.00 (1.5 ms or less)
Display colour (CoL)	Select the display colour. *: A common setting for SP1 to SP3.	1SoG (interlocked with SP1) ON: Green OFF: Red

- [F 2] Setting of SP2

Item	Explanation	Default
Output point (SP2)	Set the analogue value to switch output.	---- (Not set)
ON width (W 2)	Set the ON range to the switch output.	50
Hysteresis (H 2)	Set an appropriate hysteresis to prevent chattering.	20
Delay time (dt)	Select the delay time of the switch output. *: A common setting for SP1 to SP3.	0.00 (1.5 ms or less)
Display colour (CoL)	Select the display colour. *: A common setting for SP1 to SP3.	1SoG (interlocked with SP1) ON: Green OFF: Red

- [F 3] Setting of SP3

Item	Explanation	Default
Output point (SP3)	Set the analogue value to switch output.	---- (Not set)
ON width (W 3)	Set the ON range to the switch output.	50
Hysteresis (H 3)	Set an appropriate hysteresis to prevent chattering.	20
Delay time (dt)	Select the delay time of the switch output. *: A common setting for SP1 to SP3.	0.00 (1.5 ms or less)
Display colour (CoL)	Select the display colour. *: A common setting for SP1 to SP3.	1SoG (interlocked with SP1) ON: Green OFF: Red

- Other parameter settings

Item	Default setting
[F 7] Digital filter	0.00 ms
[F10] Sub display	std (standard)
[F11] Display resolution	1000 partitions
[F80] Power saving mode	OFF
[F81] Security code	OFF
[F90] Setting of all functions	OFF
[F97] Copy function	OFF
[F98] Output check	N/A (normal output)
[F99] Reset to default settings	OFF

## 10 Other Settings

**Snap-shot function**                      **Differential display function**  
**Peak / Bottom hold function**        **Key-lock function**

Refer to the operation manual on the SMC website (URL: <https://www.smcworld.com>) for setting these functions.

## 11 Troubleshooting

### 11.1 Error indication (Sensor monitor)

Error	Error display	Description	Measures
Over current error	Er 1	The switch output load current is 80 mA or more.	Turn the power off and remove the cause of the over current. Then supply power again.
Output detection range error	Er 3	(1) Check that the operating range for each of SP1 to SP3 is within the display range. (2) Check that the operating range of each of SP1 to SP3 is not overlapping in 3 setting mode.	Set the output point again. Set a smaller set value for the ON width and hysteresis.
Display range error	HHH	A voltage above the upper limit of the display range is applied.	Check that an analogue auto switch sensor is connected. Check the sensor connection and wiring.
	LLL	A voltage below the lower limit of the display range is applied. Sensor is not connected or wired incorrectly.	
Copy error	Er 13	Copy function has been operated incorrectly.	Press the UP and DOWN buttons simultaneously for <u>1 second or longer</u> to clear the error. Then check the wiring and model before copying again.
System error	Er 0	Displayed if an internal data error has occurred.	Turn the power off and on again. If the failure cannot be solved, contact SMC.
	Er 4		
	Er 6		
	Er 8		

If the error cannot be reset after the above measures are taken, or errors other than the above are displayed, please contact SMC.

Refer to the operation manual on the SMC website (URL: <https://www.smcworld.com>) for more detailed information about troubleshooting.

## 12 How to Order

Refer to the operation manual or catalogue on the SMC website (URL: <https://www.smcworld.com>) for How to order information.

## 13 Outline Dimensions

Refer to the operation manual or catalogue on the SMC website (URL: <https://www.smcworld.com>) for Outline Dimensions.

## 14 Maintenance

### 14.1 General Maintenance

#### Caution

- Not following proper maintenance procedures could cause the product to malfunction and lead to equipment damage.
- If handled improperly, compressed air can be dangerous.
- Maintenance of pneumatic systems should be performed only by qualified personnel.
- Before performing maintenance, turn off the power supply and be sure to cut off the supply pressure. Confirm that the air is released to atmosphere.
- After installation and maintenance, apply operating pressure and power to the equipment and perform appropriate functional and leakage tests to make sure the equipment is installed correctly.
- If any electrical connections are disturbed during maintenance, ensure they are reconnected correctly and safety checks are carried out as required to ensure continued compliance with applicable national regulations.
- Do not make any modification to the product.
- Do not disassemble the product, unless required by installation or maintenance instructions.
- The analogue ASW may malfunction unexpectedly, making it impossible to confirm safety. Therefore, perform the following maintenance or inspection regularly:
  - 1) Retightening of the mounting screws  
If the screws have become loose and the required mounting position has been lost, re-adjust the product to the correct mounting position and re-tighten the screws.
  - 2) Checking the presence or absence of damage to the lead wire  
Damage to the lead wire causes faulty insulation. If such damage is found, replace the analogue ASW or repair the lead wire.
- Do not use benzene, thinner or alcohol, etc. to clean the product. Otherwise, the surface may be damaged or the product marking may be erased.  
For a heavy stain, use a cloth that has been soaked with diluted neutral detergent and fully squeezed to wipe off the stain and wipe the surface again with a dry cloth.

#### How to reset the product after a power cut or forced de-energizing

The settings for the product are retained in memory prior to the power loss or de-energizing of the product.

The output condition is also recoverable to that prior to the power loss or de-energizing. However, this may change depending on the operating environment. Therefore, check the safety of the whole installation before operating the product.

If the installation is using accurate control, wait until the product has warmed up (approximately 10 to 15 minutes) before operation.

## 15 Limitations of Use

### Limited warranty and Disclaimer/Compliance Requirements

Refer to Handling Precautions for SMC Products.

## 16 Product disposal

This product should not be disposed of as municipal waste. Check your local regulations and guidelines to dispose of this product correctly, in order to reduce the impact on human health and the environment.

## 17 Contacts

Refer to [www.smcworld.com](https://www.smcworld.com) or [www.smc.eu](https://www.smc.eu) for your local distributor / importer.

## SMC Corporation

URL : <https://www.smcworld.com> (Global) <https://www.smc.eu> (Europe)  
SMC Corporation, 4-14-1, Sotokanda, Chiyoda-ku, Tokyo 101-0021, Japan  
Specifications are subject to change without prior notice from the manufacturer.  
© 2023 SMC Corporation All Rights Reserved.  
Template DKP50047-F-085M