



ORIGINAL INSTRUCTIONS

Instruction Manual

Soft Start-up Valve/Soft Start-up Valve Lockout Type

Series AV2000~5000-A/AVL2000~5000-A

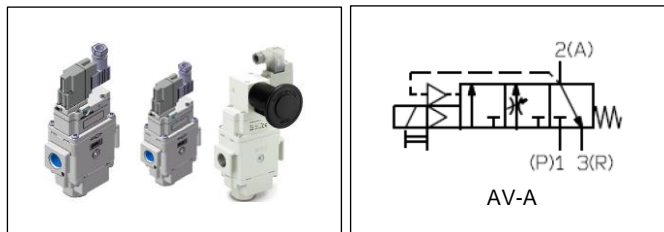

The intended use of this product is to protect machine mechanism against sudden movement during start up.

1 Safety Instructions

These safety instructions are intended to prevent hazardous situations and/or equipment damage. These instructions indicate the level of potential hazard with the labels of "Caution," "Warning" or "Danger." They are all important notes for safety and must be followed in addition to International Standards (ISO/IEC^{*)}, and other safety regulations.

- ^{*)} ISO 4414: Pneumatic fluid power - General rules relating to systems.
- ISO 4413: Hydraulic fluid power - General rules relating to systems.
- IEC 60204-1: Safety of machinery - Electrical equipment of machines. (Part 1: General requirements)
- ISO 10218-1: Robots and robotic devices - Safety requirements for industrial robots - Part 1: Robots.

- Refer to product catalogue, Operation Manual and Handling Precautions for SMC Products for additional information.
- Keep this manual in a safe place for future reference.

Caution	Caution indicates a hazard with a low level of risk which, if not avoided, could result in minor or moderate injury.
Warning	Warning indicates a hazard with a medium level of risk which, if not avoided, could result in death or serious injury.
Danger	Danger indicates a hazard with a high level of risk which, if not avoided, will result in death or serious injury.

Warning

- Always ensure compliance with relevant safety laws and standards.**
- All work must be carried out in a safe manner by a qualified person in compliance with applicable national regulations.
- If this equipment is used in a manner not specified by the manufacturer, the protection provided by the equipment may be impaired.

Caution

- The product is provided for use in manufacturing industries only. This product must not be used in residential areas.

Warning

- When using a solenoid valve or actuator on the outlet side of this product, implement appropriate measures to prevent potential danger caused by actuator operation.
- This product may experience air leakage (within tolerance), therefore this valve is not suitable for holding pressure in a vessel for a long period of time.
- This valve is not to be used as an emergency shutoff valve. Using the valve in such applications, take a separate measure to ensure safe use.
- Provide ventilation when using valve in a confined area, such as in a closed control panel. For example, install a ventilation opening, etc. in

1 Safety Instructions - continued

order to prevent pressure from increasing inside of the confined area and to release the heat generated by the valve.

- The circuit designer shall ensure external cables have strain relief and correct protective bonding in accordance with the requirements of EN 60204-1

The circuit designer shall ensure correct insulation monitoring in accordance with requirements of EN60204-1.

2 Specifications

2.1 Mechanical Specification

Model	AV(L)2000-A	AV(L)3000-A	AV(L)4000-A	AV(L)5000-A			
Port size	1(P), 2(A) 3(R)	1/4 3/8	1/2 3/8	3/4 1/2	1 3/4		
Pressure Gauge Port size	1/8						
Fluid	Air						
Ambient/Fluid Temperature	0 to 50°C ^{Note 1)}						
Proof Pressure	1.5 MPa						
Operating Pressure	0.2 to 1.0 MPa						
Max. operating frequency	5 cycles/min not exceeding 100 cycles/day						
Min. operating frequency	Once every 30 days						
Min. air quality	5 µm filtration						
IP rating (based on IEC60529)	IP65 (DIN terminal and M12 connector) IP20 (Grommet)						
Weight (kg)	AV	0.43	0.45	0.80	1.30	1.25	
	AVL (manual operation)	0.62	0.64	0.99	1.51	1.46	
	AVL (manual operation with solenoid valve)	0.67	0.68	1.03	1.55	1.50	
Flow characteristics	1(P)→2(A)	C(dm ³ /s·bar)	9.2	13.1	19.2	34.8	41.3
		b	0.36	0.27	0.32	0.66	0.34
		Cv	2.4	3.1	5.1	12.6	13.7
	2(A)→3(R)	C(dm ³ /s·bar)	8.8	9.2	10.1	23.7	
		b	0.46	0.48	0.55	0.67	
		Cv	2.5	2.6	3.2	9.2	

Impact resistance ^{Note 2)}	1000 m/s ² (11ms)
Vibration resistance ^{Note 3)}	30 m/s ² (0.35mm)
Mounting orientation	Unrestricted

Table 1.

Note 1) Please use dry air when operating at a low temperature to avoid freezing
 Note 2) Two axes (horizontal and vertical) and two directions were tested, and no malfunction occurred (pulse shape: sine shape), 3 times for each condition (pilot valve ON and OFF, test sample mounted with bracket)

Note 3) No malfunction occurred in a sweep cycle test between 10 to 50 Hz at vibration sweep 0.35mm. The test was performed in the two axes and two directions, 7mm per cycle (20 cycles) 20 times for each condition (pilot valve ON and OFF)

2.2 Electrical Specification

Electrical Entry	Grommet	DIN Terminal	M12 Connector
Coil Rated Voltage (V)	DC AC 50/60 Hz	24, 12 100,200,110 (115), 220 (230) ^{Note 1)}	
Power Consumption (W)	DC AC	0.35 (with light: 0.4) 0.35 (with light: 0.45)	With light: 0.4
Allowable voltage	DC	±10% of rated voltage	
		±10% of rated voltage	
		±10% of rated voltage	
	AC	±10% of rated voltage (-15% to +5% of rated voltage)	
		±10% of rated voltage	
		±10% of rated voltage (-15% to +5% of rated voltage)	

2 Specifications – continued

Apparent Power	AC	100V	0.78 (with light: 0.87)	
		110V (115V)	0.86 (with light: 0.97) [(0.94 (with light: 1.07))]	
Surge Voltage Suppressor	AC	200V	1.15 (with light: 1.30)	
		220V (230V)	1.27 (with light: 1.46) (1.39 (with light: 1.60))	
Indicator		LED	LED (neon light for AC)	LED

Table 2.

Note 1) The 110VAC and 115VAC are interchangeable. The 220VAC and 230VAC are interchangeable as well.
 Note 2) Valve state is not defined if electrical input is outside of specification.

Warning

Special products (-X) might have specifications different from those shown in this section. Contact SMC for specific drawings.

3 Installation

3.1 Installation

Warning

- Do not install the product unless the safety instructions have been read and understood.
- Operation manual/Instruction manual**
Mount and operate the product after reading the manual carefully and understanding its contents. Keep the manual in a place where it can be referred to as necessary.
- Painting and coating**
Warnings and specifications printed or labelled on a product should not be erased, removed or covered up. Please contact SMC before painting the resin parts, as this may cause adverse effects depending on the solvent.

Warning

- Confirm the specifications**

The product presented in this document is designed for use only for use in compressed air systems. Do not operate at pressures or temperatures, etc., beyond the range of specifications, as this can cause damage or malfunction (refer to specifications). Please contact SMC if using for any fluid other than compressed air.

- Operation of closed centre solenoid valves**
Even if this product is used for closed centre solenoid valves or actuator with a load of 50% or more, lurching (quick extension) cannot be prevented.
- Using a regulator on the outlet side**
When mounting a regulator on the outlet side (A port side), use a residual pressure relief regulator (AR25K to 40K) or check type regulator. With a standard regulator (AR10 to 60), the outlet side pressure may not be released when this valve exhausted.

- Operation of solenoid valves on the outlet side**
To operate solenoid valves mounted on this product's outlet side (A port side), make sure that the outlet side's pressure (P_A) has increased to the pressure equal to the inlet side (P_P).
- Operation**
The residual pressure release function of this product is for emergency use only. Avoid using this valve in the same manner as ordinary 3 port valves.
- Using a lubricator**
If mounting a lubricator, mount it on the inlet side (P port side) of this product. If mounted on the outlet side (A port side), back flow of oil will occur and may spurt out of valve R's port.

- Operating for air blowing**
This product cannot be operated for air blowing due to the mechanism that switches the main valve to be fully open after the outlet side's pressure increases to approximately 1/2 of the inlet side.

Warning

- Solenoid valve for 200, 220 VAC**

3 Installation - continued

The AC solenoid valves with the grommet have a built-in rectifier circuit in the pilot section to operate the DC coil.
 With the 200V and 220 VAC pilot valves, this built-in rectifier generates heat when energised. The surface may become very hot depending on the energised condition. To prevent burns, do not touch the solenoid valve.

3.2 Environment

Warning

- Do not use in an environment where corrosive gases, chemicals, salt water or steam are present.
- Do not use in an explosive atmosphere.
- Do not expose to direct sunlight. Use a suitable protective cover.
- Do not install in a location subject to vibration or impact in excess of the product's specifications.
- Do not mount in a location exposed to radiant heat that would result in temperatures in excess of the product's specifications.
- Take suitable protective measures if water, oil or welding splatter is likely to adhere to the valve.
- Take measures to ensure air quality, such as installing an after-cooler, air dryer, or water separator. Compressed air that contains a large amount of drainage can cause a malfunction of pneumatic equipment such as valves.
- Take suitable measures to prevent dust or noise if operating in an environment generating dust or intrusive valve switching noise, by providing a silencer in the R port.
- Products compliant with IP65 and IP67 enclosures are protected against dust and water, however, these products cannot be used in water.
- Products compliant with IP65 and IP67 enclosures satisfy the specifications by mounting each product properly. Be sure to read the Specific Product Precautions for each product.

Caution

- Low temperature operation**
Although the valve can be operated at temperature as low as 0°C, measures should be taken to avoid solidifying or freezing drainage and moisture.

3.3 Piping

Caution

- Before connecting piping make sure to clean up chips, cutting oil, dust etc.
- When installing piping or fittings, ensure sealant material does not enter inside the port. When using seal tape, leave 1.5-2 threads exposed on the end of the pipe/fitting.
- Refer to the instruction/operation manual during installation and make sure to connect correct supply port, etc.
- F.R.L module combination**
When connecting to a modular F.R.L unit (AC20 to 60), select one of the spacers, included amongst the accessories. However, modular combinations with the AC40-06 are not possible. Furthermore, connect soft start-up valves to the outlet side of the F.R.L. combination.

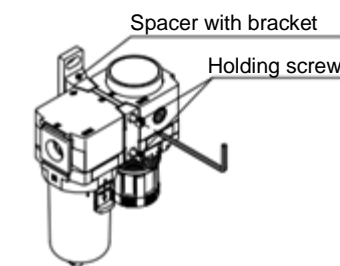

Figure 1. F.R.L module combination

3 Installation - continued



Figure 2. Y#00-D & Y#00T-D

Size	Spacer with bracket	Tightening torque [N·m]
AC20	Y200T-D	0.36 ± 0.036
AC30	Y300T-D	1.2 ± 0.05
AC40	Y400T-D	1.2 ± 0.05
AC60	Y600T-D	2.0 ± 0.1

Table 3.

Inlet side piping conditions

The nominal size of the piping materials or equipment bore should be equal to or larger than the soft start-up valve's port size. The combined sonic conductance of the inlet side's (P port side's) piping or equipment should be equal to or larger than the values below.

Model	Combined sonic conductance [dm ³ /(s·bar)]
AV2000-A	1
AV3000-A	4
AV4000-A	7
AV5000-A	10

Table 4.

When the piping is restricted or the supply pressure is insufficient, the

main valve will not switch, and air leakage may occur from the R port.

- Tighten fittings to the specified tightening torque.

Connecting threads (Rc)	Proper tightening torque [N·m]
1/4	12 to 24
3/8	22 to 24
1/2	28 to 30
3/4	28 to 30
1	36 to 38

Table 5.

3.4 Lubrication

Caution

- SMC products have been lubricated for life at manufacture, and do not require lubrication in service.
- If a lubricant is used in the system, refer to catalogue for details. Once lubricant is utilized within the system, since the original lubricant applied within the product during manufacturing will be washed away, please continue to supply lubrication to the system. Without continued lubrication, malfunctions could occur. If turbine oil is used, refer to the corresponding Material Safety Data Sheet (MSDS).
- Lubrication amount**
If a lubricant is applied excessively, it may accumulate inside the pilot valve, causing malfunction or delayed response. Avoid using large amount of lubricant. If it is not avoidable, use an external pilot type, whereby supply air to the external pilot port contains no oil. This prevents accumulation of the oil inside the pilot valve.

3.5 Wiring

Caution

Voltage

When electric power is connected to a solenoid valve, make sure to apply correct voltage. Incorrect voltage may cause malfunction or coil damage.

3 Installation - continued

Connections

Check if the connections are all correct after completing the wiring.

External force

An excessive force to the lead wire may cause wire breakage. Take appropriate measures to avoid applying a force of 30N or more to the lead wire.

3.6 Air supply

Warning

- Use clean air. If the compressed air supply includes chemicals, synthetic materials (including organic solvents), salinity, corrosive gas etc., it can lead to damage or malfunction.

Caution

- Install an air filter upstream of the valve. Select an air filter with a filtration size of 5 μm or smaller. The compressed air containing a large amount of moisture may result in a large amount of moisture may result in a malfunction of the valve or other pneumatic equipment.
- Install an after-cooler, air dryer or water separator or otherwise take an appropriate measure.

3.7 Surge voltage suppressor

Caution

Surge suppression should be specified by using the appropriate part number. If a valve type without suppression (Type 'NIL') is used, suppression must be provided by the host controller as close as possible to the valve.

DC power supply

Grommet – standard type (with polarity)

With light/surge voltage suppressor (GZ)

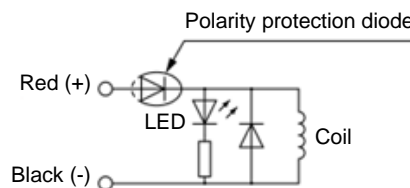

Figure 3.

- Correctly connect the lead wires to positive (+) and negative (-) indications on the connector.
- Solenoids, whose lead wires have been pre-wired: positive side (+) is red and negative side (-) is black.

DIN Terminal

With light/surge voltage suppressor (DZ, YZ)

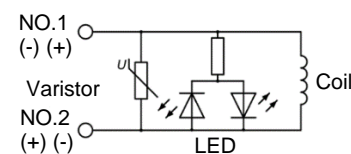

Figure 4.

- DIN terminal has no polarity.

M12 Connector

With light/surge voltage suppressor (WOZ)

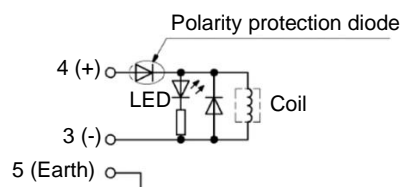

Figure 5.

- Connect in accordance with the +, - polarity indication.

3 Installation - continued

Pin wiring diagram:

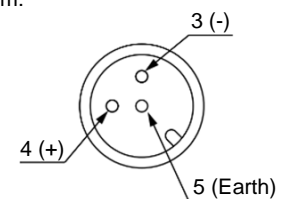

Figure 6.

AC power supply

DIN Terminal

With light (DZ) and (YZ)

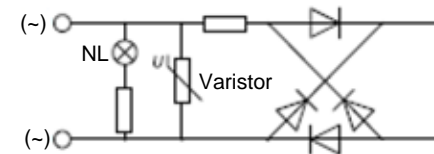

Figure 7.

- Surge voltage suppressor of varistor has residual voltage corresponding to the protective element and rated voltage; therefore, protect the controller side from the surge voltage. The residual voltage of the diode is approximately 1V.

Caution

- At times of sudden interruption of the power supply, the energy stored in a large inductive device may cause non-polar type valves in a de-energised state to switch.
- When installing a breaker circuit to isolate the power, consider a valve with polarity (with polarity protection diode), or install a surge absorption diode across the output of the breaker.

3.8 How to use DIN Terminal

Caution

Construction

- Type "Y":** Y type DIN connector is a DIN connector that conforms to the DIN pitch 8 mm standard.
- Type "D":** D type DIN connector with 9.4 mm pitch between terminals, is not interchangeable with the Y type connector.
- To distinguish between "Y" and "D" type DIN connector, "Y" has "N" listed at the end of the voltage symbol. For connector parts without lights, "N" is not indicated. Refer to the name plate to distinguish.
- "Y" dimensions are the same as the "D" type DIN connector.

Connection

- Loosen the holding screw and pull the connector out of the solenoid valve terminal block.
- After removing the holding screw, insert a flat head screwdriver, etc. into the notch on the bottom of the terminal block and pry it open, separating the terminal block and the housing.
- Loosen the screw (slotted screws) on the terminal block. Insert the lead cores wires into the terminals according to the connection method and secure the wires by re-tightening the terminal screw.
- Secure the cord by tightening the gland nut.

Caution

When making connections, take note that using other than the supported size (ø3.5 to ø7) heavy duty cord will not meet IP65 (enclosure) standards. Ensure to tighten the gland nut and holding screw within their specified torque ranges.

Changing the entry direction

After separating the terminal block and housing, the cord entry can be changed by attaching the housing with 90° interval direction.

Note that the direction cannot be changed toward this product.

*When equipped with light, handle carefully to avoid damage to the light with the lead wires in the cable.

NOTE: Plug in and pull out the connector vertically without tilting to one side.

3 Installation - continued

Compatible cable

Cable O.D.: ø3.5 to ø7

(Reference) 0.5mm², 2-core or 3-core, equivalent to JIS C 3306

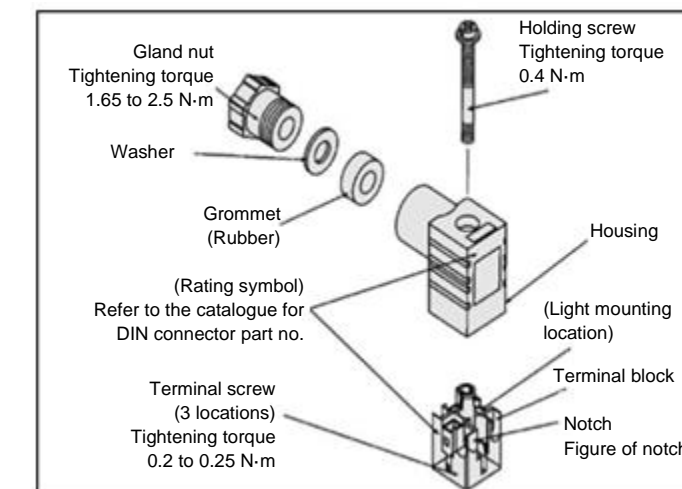

Figure 8.

DIN Connector part numbers

Type	Option	Rated Voltage	Rated Symbol	Part number (AV)	Part number (AVL)
"D" Type	Without light	-	-	SY100-61-1	SY100-61-1-C
	With light	24 VDC	24 V	SY100-61-3-05	SY100-61-3-05-C
		12 VDC	12 V	SY100-61-3-06	SY100-61-3-06-C
		100 VAC	100 V	SY100-61-2-01	SY100-61-2-01-C
		200 VAC	200 V	SY100-61-2-02	SY100-61-2-02-C
"Y" Type	Without light	-	-	SY100-82-1	SY100-82-1-C
	With light	24 VDC	24 V	SY100-82-3-05	SY100-82-3-05-C
		12 VDC	12 V	SY100-82-3-06	SY100-82-3-06-C
		100 VAC	100 V	SY100-82-2-01	SY100-82-2-01-C
		200 VAC	200 V	SY100-82-2-02	SY100-82-2-02-C
110 VAC(115VAC)	110 V	SY100-82-2-03	SY100-82-2-03-C		
220VAC (230VAC)	220 V	SY100-82-2-04	SY100-82-2-04-C		

Table 6.

Circuit Diagram with light

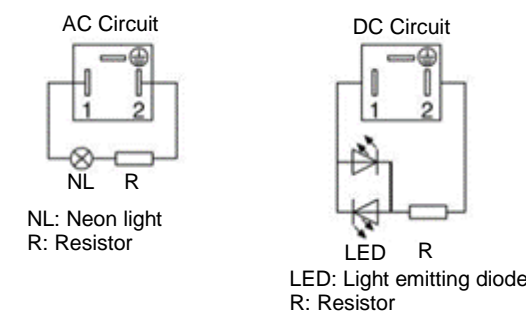

Figure 9.

4 Settings

4.1 Initial speed adjustment

To perform the initial speed adjustment of the outlet side actuator, supply air from this valve's inlet side and turn ON the pilot valve. Then, rotate the needle counter-clockwise from the fully closed position.

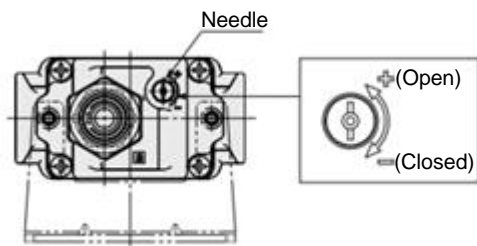

Figure 10.

4.2 Manual override (if fitted)

Warning

Since connected equipment will operate when the manual override is activated, confirm that conditions are safe prior to activation.

• Push-turn locking slotted type [Type B]

While pressing, turn in the direction of the arrow.

If it is not turned, it can be operated in the same way as the non-locking type.

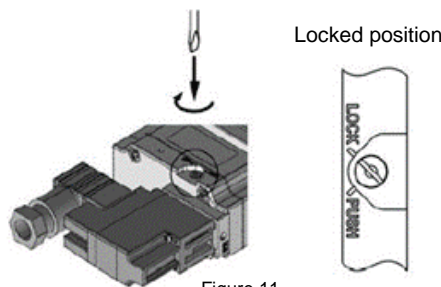

Figure 11.

Caution

When operating the locking type D with a screwdriver, turn it gently using a watchmaker's screwdriver (Torque: Less than 0.1N·m)

• Push-turn locking lever type [Type C]

While pressing, turn in the direction of the arrow.

If it is not turned, it can be operated in the same way as the non-locking type.

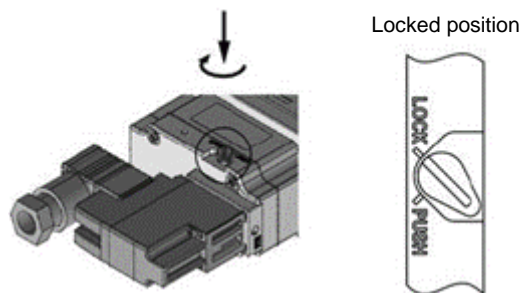

Figure 12.

Caution

When locking the manual override on the push-turn locking type (B, C), make sure to push it down before turning. Turning without first pushing it down can cause damage to the manual override and failures such as air leakage, etc.

• Non-Locking push type

Press the blue button to override solenoid valve.

4 Settings - continued

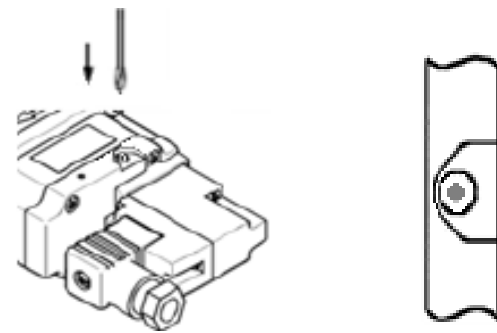

Figure 13.

5 How to Order

Refer to drawings or catalogue for 'How to Order'

6 Outline Dimensions

Refer to drawings or catalogue for outline dimensions.

7 Maintenance

7.1 General maintenance

Caution

- Not following proper maintenance procedures could cause the product to malfunction and lead to equipment damage.
- If handled improperly, compressed air can be dangerous.
- Maintenance of pneumatic systems should be performed only by qualified personnel.
- Before performing maintenance, turn off the power supply and be sure to cut off the supply pressure. Confirm that the air is released to atmosphere.
- After installation and maintenance, apply operating pressure and power to the equipment and perform appropriate functional and leakage tests to make sure the equipment is installed correctly.

- If any electrical connections are disturbed during maintenance, ensure they are reconnected correctly, and safety checks are carried out as required to ensure continued compliance with applicable national regulations.
- Do not make any modification to the product.
- Do not disassemble the product, unless required by installation or maintenance instructions.
- **Removal of equipment, and supply/exhaust of compressed air**
Before equipment removal, ensure that measures are in place to prevent falling or run-away of the driven objects. Then, cut off the air supply, electric power and exhaust air pressure from the system using the residual pressure release function.
- If handled improperly, damage or malfunction of machinery or equipment may occur.
- **Low frequency operation:**
Valves should be operated at least once every 30 days to prevent malfunction (use caution regarding the air supply).
- **Drain flushing**
Remove drained fluid from air filters periodically.

Caution

7.2 Pilot valve replacement

Ensure gaskets are in good condition, not deformed and are dust and debris free.

When mounting valves ensure gaskets are present, aligned and securely in place and tighten screws to a torque of 0.85±0.05 N·m.

8 Limitations of Use

8.1 Limited warranty and disclaimer/compliance requirements

Refer to Handling Precautions for SMC Products.

Warning

8.2 Safety relays

If a safe output from a safety relay or PLC is used to operate this valve, ensure that any output test pulse duration is shorter than 1 ms to avoid the valve solenoid responding.

8.3 Effect of energy loss

The system designer should determine the effect of the possible failure modes of the product on the system.

Energy source status	Single
Air supply present, electricity cut	Spool returns to the off position by spring force
Air supply cut before electricity cut	Spool returns to the off position by spring force
Air supply cut after electricity cut	Spool returns to the off position by spring force

Table 7.

8.4 Soft start valve

Soft start function is not to be used as a safety function.

Caution

8.5 EMC restrictions

8.5.1 Class and group description

- This product is group 1, class A equipment according to EN55011.
- Group 1 equipment does not intentionally generate radio-frequency energy in the range 9kHz to 400 GHz.
- Class A equipment is equipment suitable for use in all locations other than those allocated in residential environments and those directly connected to a low voltage power supply network which supplies buildings used for domestic purposes.
- This equipment is not intended for use in residential environments and may not provide adequate protection to radio reception in such environments.

8.5.2 Cable length to connect

The cable to connect the product shall be less than or equal to 30m.

8.5.3 Connecting the power supply

This product is not intended to be directly connected to any DC Distribution network.

8.6 Leakage voltage

Ensure that any leakage voltage caused by the leakage current when the switching element is OFF causes ≤ 3% (for DC coils) or ≤ 8% (for AC coils) of the rated voltage across the valve.

9 Product Disposal

This product shall not be disposed of as municipal waste. Check your local regulations and guidelines to dispose this product correctly, in order to reduce the impact on human health and the environment.

10 Contacts

Refer to www.smcworld.com or www.smc.eu for your local distributor/importer.

SMC Corporation

URL : <https://www.smcworld.com> (Global) <https://www.smc.eu> (Europe)
SMC Corporation, 4-14-1, Sotokanda, Chiyoda-ku, Tokyo 101-0021, Japan
Specifications are subject to change without prior notice from the manufacturer.
© 2023 SMC Corporation All Rights Reserved.
Template DKP50047-F-085M