



Refrigerated Air Dryer Operating Manual for Option

IDF4E-10-T~IDF11E-10-T
IDF4E-20-T~IDF11E-20-T
IDU3E-10-T~IDU6E-10-T
IDU3E-20-T~IDU6E-20-T

This operating manual is for optional specifications.
For the other parts than the options, refer to the standard operation manual.

1. Specification

(1) Run signal, Alarm signal, and terminal block

2. About the signal, the Alarm signal, and the terminal block

- (1) Please remove the Riyapanel fixation screw, and detach Riyapanel.
(IDF4E,6E : 5 pieces, IDF8E,11E : 6 pieces)
- (2) Please pass the power supply cable through the Grommet 1 with membrane with the film and connect it.
- (3) Please pass the signal cable through the Grommet 2 with membrane with the film and connect it.

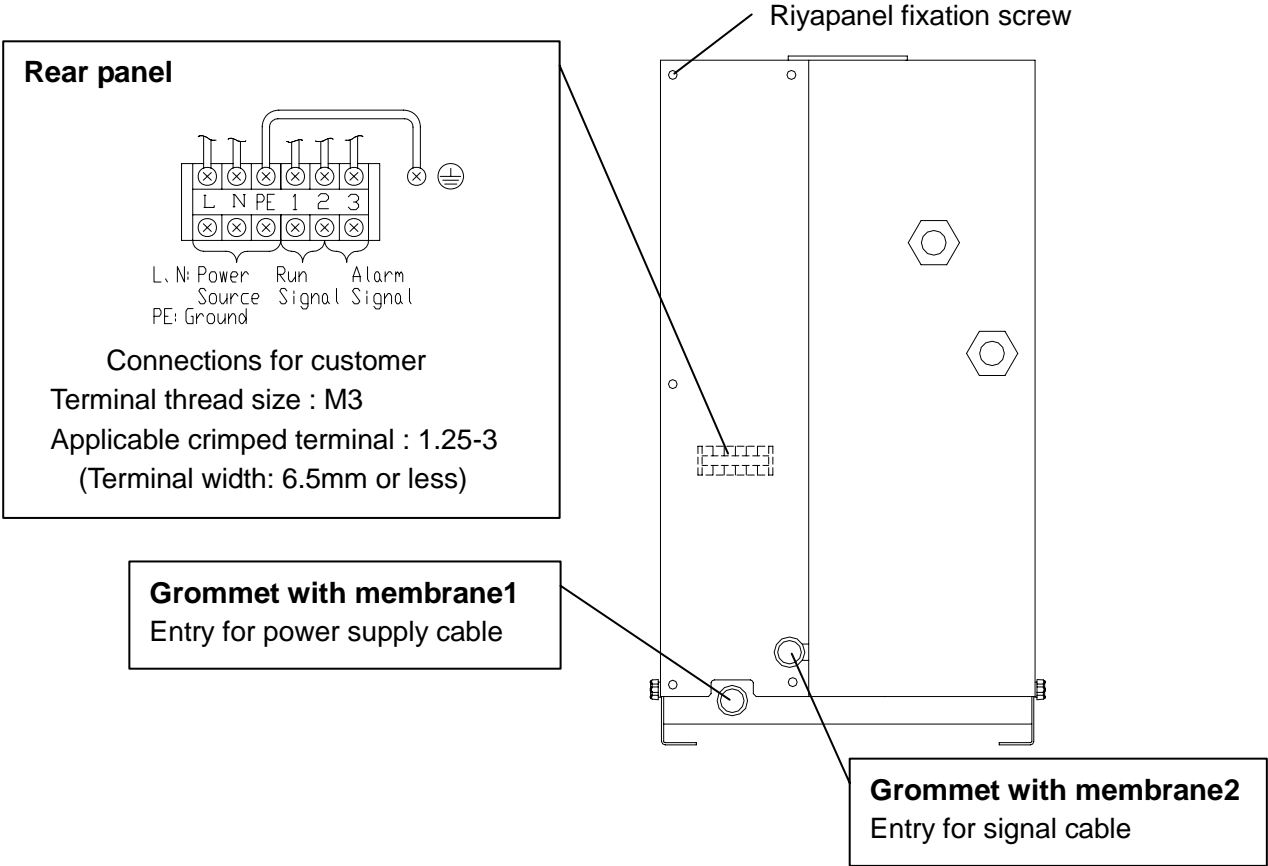

3. Signal sensing and remote control

- Signal is no-voltage contact, and contact capacity is AC200V. The minimum current value for 1A is AC10mA, and DC30mA.
 - For remote controlling, turn on/ off the power supply after turning on the switch with light at the main body.
 - For remote controlling, start the operation after stopping for 3 minutes or more.
- In addition, frequency of start/ stop shall not be more than 5 times per hour (for preventing motor trouble).

4. Electric circuit

IDF4E~8E-10-T
IDU3E,4E-10-T

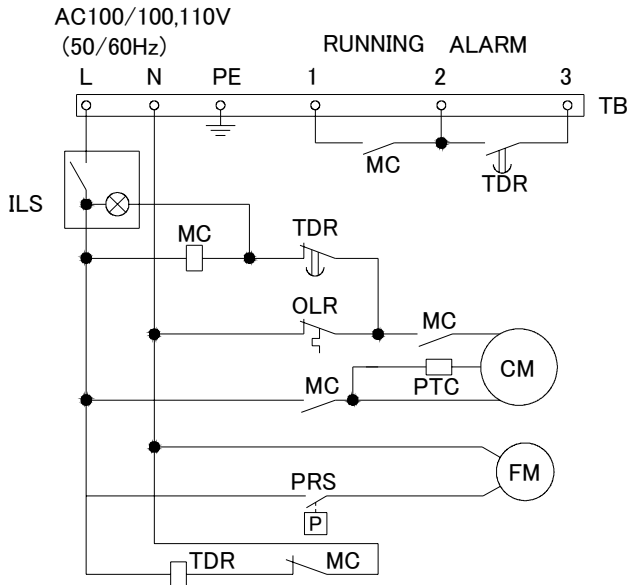

IDF4E~8E-20-T
IDU3E,4E-20-T

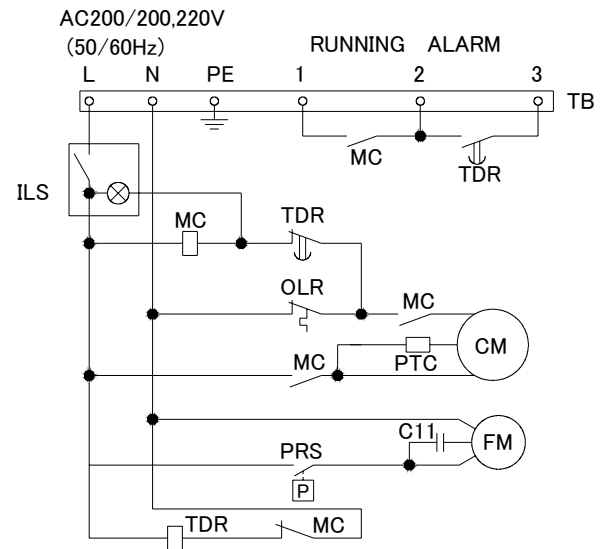

IDF11E-10-T
IDU6E-10-T

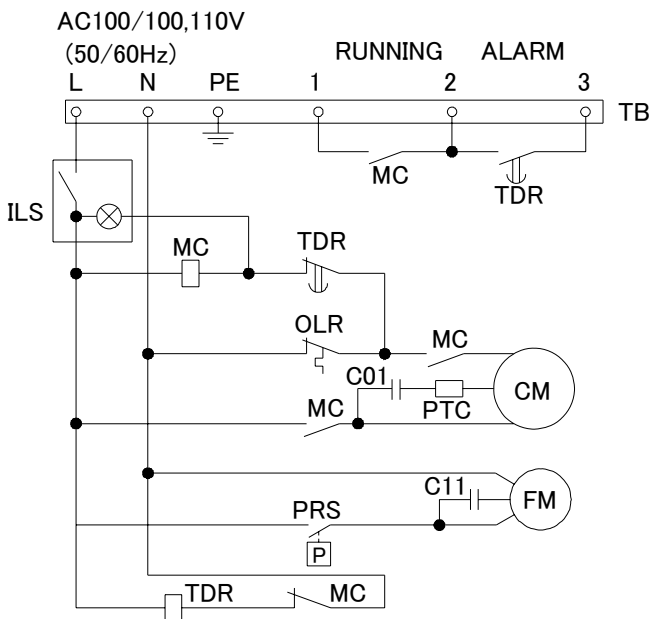

IDF11E-20-T
IDU6E-20-T

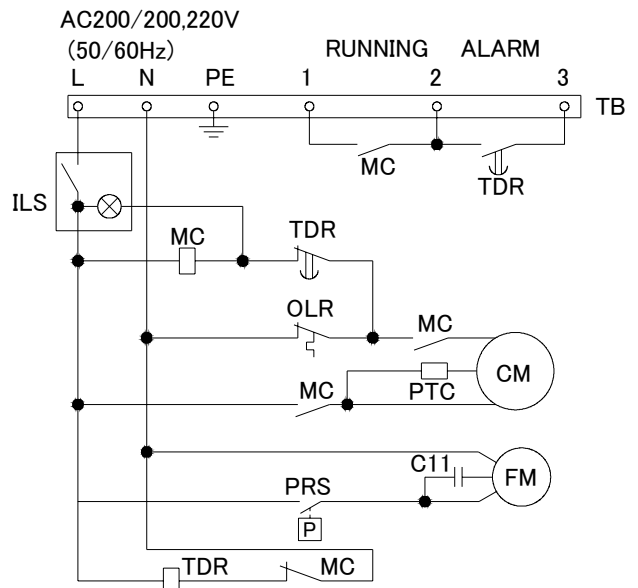

| 記号 SYMBOL | 名称 DEVICE NAME | 記号 SYMBOL | 名称 DEVICE NAME |
|--------------|----------------------------------------------|--------------|------------------------------------------|
| CM | 冷凍用圧縮機 COMPRESSOR MOTOR | MC | 電磁接触器 MAGNETIC CONTACTOR |
| FM | 凝縮機用ファンモータ FAN MOTOR FOR CONDENSER | TDR | 遅延リレー TIME DELAY RELAY |
| OLR | オーバロードリレー OVER LOAD RELAY | TB | 端子台 TERMINAL BLOCK |
| PRS | 冷媒圧カスイッチ PRESS. SWITCH (REFRIG) | C01 | 冷凍用圧縮機用キャパシタ CAPACITOR FOR COMPRESSOR |
| ILS | ランプ付スイッチ ILLUMINATED SWITCH | C11 | ファンモータ用キャパシタ CAPACITOR FOR FAN MOTOR |
| PTC | PTCスタータ (起動リレー) PTC STARTER (START RELAY) | - | - |

| 記号 SYMBOL | 線色 WIRE COLOR | 記号 SYMBOL | 線色 WIRE COLOR |
|--------------|------------------|--------------|------------------|
| (BK) | 黒 BLACK | (SY) | 空 SKY BLUE |
| (WH) | 白 WHITE | (YE) | 黄 YELLOW |
| (GY) | 灰 GRAY | (BR) | 茶 BROWN |
| (OR) | 橙 ORANGE | (G/Y) | 緑/黄 GREEN/YELLOW |
| (RE) | 赤 RED | - | - |