



# Refrigerated Air Dryer Operation Manual for Option

**IDF22E-20-T, IDF22E-30-T**  
**IDF37E-20-T, IDF37E-30-T**  
**IDF55E-30-T**  
**IDF75E-30-T**

- This operation manual should be used for option specification T.
- For the other option specifications, refer to the operation manuals corresponding to the option number.
- For the other parts than the options, refer to the standard operation manual.

## 1. Safety instructions

When handling the product, take care to the following precautions.



### Warning

**Only qualified person must perform wiring and observing the following points.**

1. Be sure to shut off the power supply before wiring. For safety, do not perform any work on the unit with the power supply on. The power supply cannot be completely shut off just by turning off the illuminated switch. Be sure to turn off all power lines connected to the product.
2. Supply the power from a stable source, free from surges.
3. Be sure to mount the Ground Fault Circuit Interrupter (GFCI) with adequate sensitivity and load capacity to prevent electrical shock and protect the refrigerating compressor motor from burning out.
4. Provide the power suitable for the product specifications.
5. Be sure to ground the product for the safety. Without grounding, the GFCI can not operate normally.
6. Do not ground to water pipe, gas tube or lightening rod line.
7. Do not connect too many wires to the same outlet, which could results in heat generation and fire.
8. Do not retrofit the wiring of the dryer and the power supply line.
9. For the use of the product in Europe, mount the breaker compatible to IEC standard to the power supply for the product.

## 2. Specification

- Mounting remote signal terminal (Running and Alarm)
- The Running (terminal 1-2) is in a short circuit state during operation.
- The Alarm (terminal 2-3) is in a short circuit state during alarm.  
 Max. Load: AC220V, 5A (Running)    DC24V, 5A (Alarm)    Min. Current: 5mA
- \* For IDF22E-20-T, IDF37E-20-T and IDF75E-30-T, even if the over load relay operates, the Alarm is not output.

## 3. Remote operation

- Turn on switch with lamp and ON/OFF power supply for remote operation.
- Start operation after stopping for 3 minutes or more.
- In addition, frequency of start/stop shall not be more than 5 times per hour.  
 (for preventing compressor motor trouble.)

4. Installation

- Remove the Front panel.
- Insert the power cord through the Rubber Grommet and connect it to terminal block.
- Insert the signal cord through the Grommet and connect it to terminal block.
- Install Front panel.

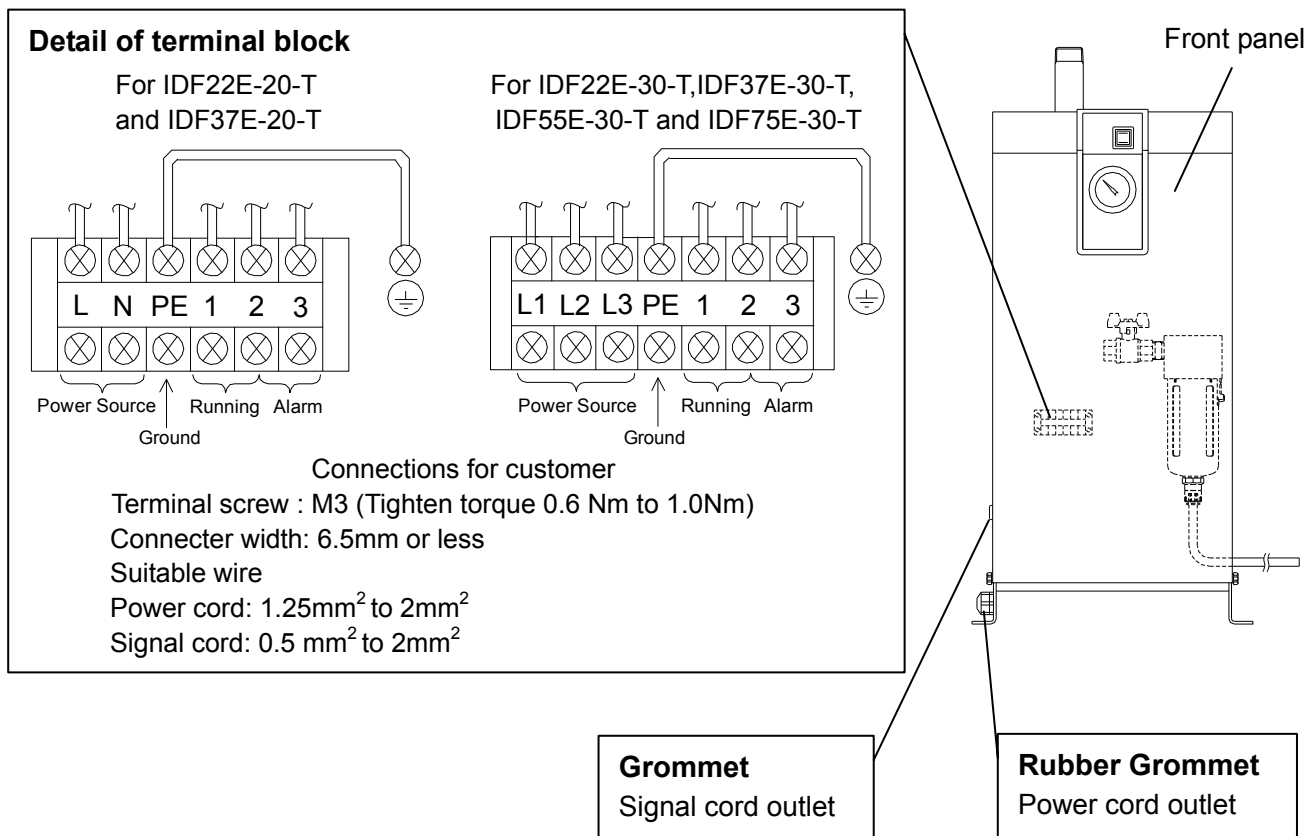

5. Electric circuit

**IDF22E-20-T, IDF37E-20-T**

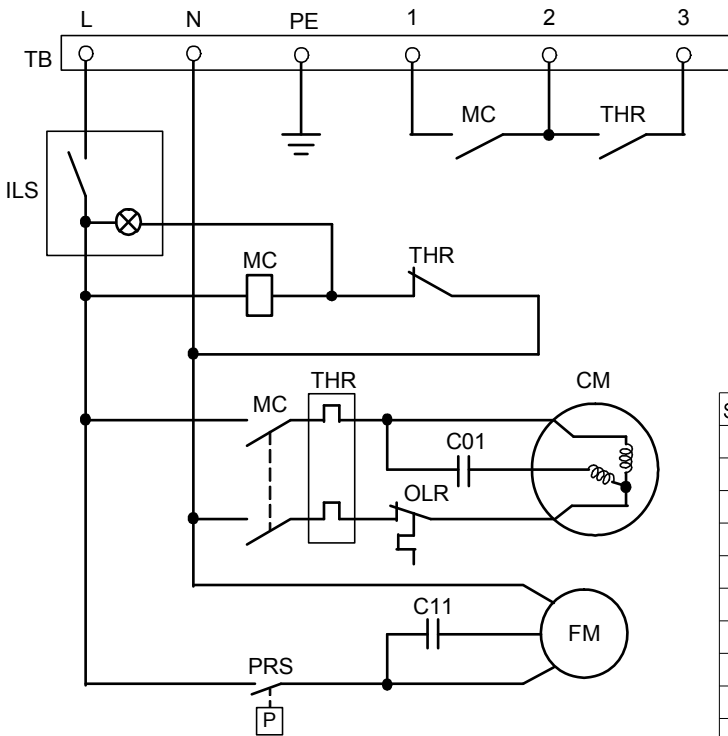

SYMBOL	DESCRIPTION
CM	Refrigerating Compressor
OLR	Overload Relay
FM	Fan Motor
PRR	Phase Reversal relay
C01	Capacitor For Starting Refrigerating Compressor
C11	Capacitor For Running Fan Motor
ILS	Switch with Lamp
MC	Magnetic Contactor
THR	Thermal Relay
THS	Thermostat
TB	Terminal Block
PRS	Pressure Switch
TDR	Time Delay Relay

**IDF22E-30-T, IDF37E-30-T**

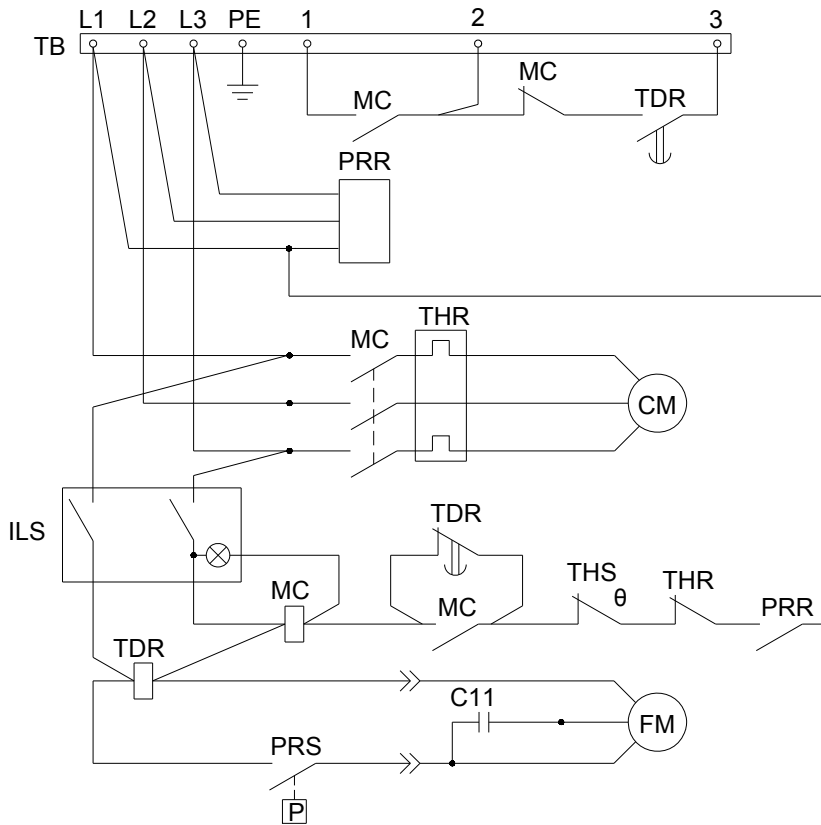

**IDF55E-30-T**

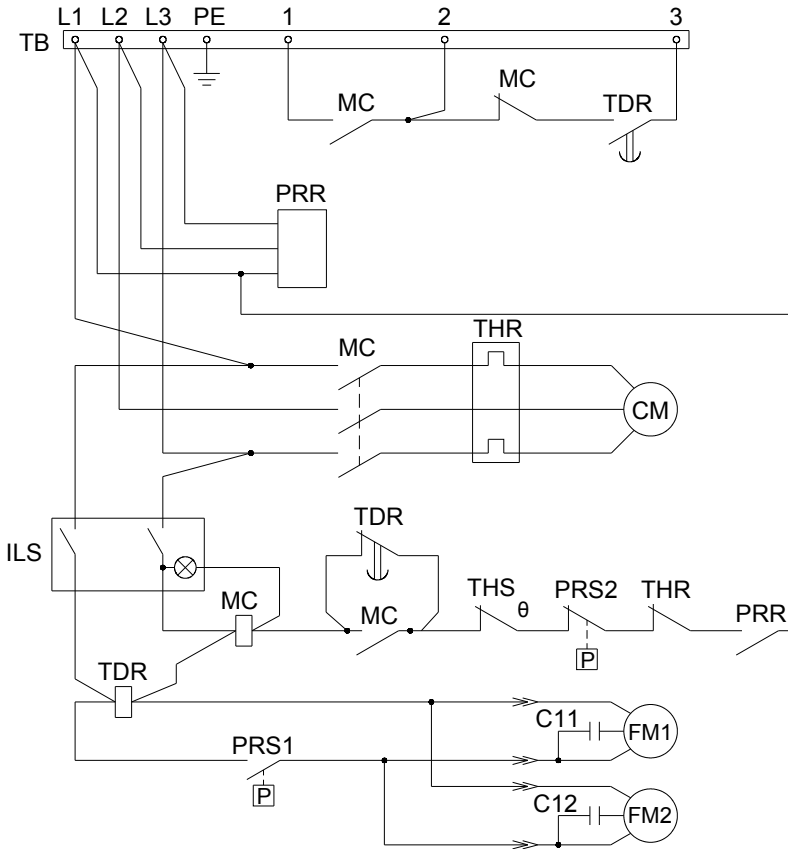

SYMBOL	DESCRIPTION
CM	Refrigerating Compressor
OLR	Overload Relay
FM	Fan Motor
FM1	Fan Motor
FM2	Fan Motor
PRR	Phase Reversal relay
C11	Capacitor For Running Fan Motor
C12	Capacitor For Running Fan Motor
ILS	Switch with Lamp
MC	Magnetic Contactor
MC1	Magnetic Contactor
MC2	Magnetic Contactor
THR	Thermal Relay
THS	Thermostat
TB	Terminal Block
PRS1	Pressure Switch
PRS2	High Pressure Switch
THP	Thermal Protector
TDR	Time Delay Relay

**IDF75E-30-T**

