

# Clean Regulator

## SRH Series

RoHS



- ARJ
- AR425 to 935
- ARX
- AMR
- ARM
- ARP
- IR□-A
- IR
- IRV
- VEX
- SRH**
- SRP
- SRF
- ITV
- IC
- ITVH
- ITVX
- PVQ
- VY1
- VBA
- VBAT
- AP100

Contamination controlled stainless steel regulator

# Clean Regulator

## SRH Series

Contamination controlled stainless steel regulator

### Outstanding corrosion resistance

All metal parts in contact with fluid use stainless steel 316

### Oil free

Parts assembled without any use of oils



### 2 types of diaphragm material available

Depending upon the application, PTFE (Grade A) or fluororubber (Grade B) can be selected for the diaphragm material

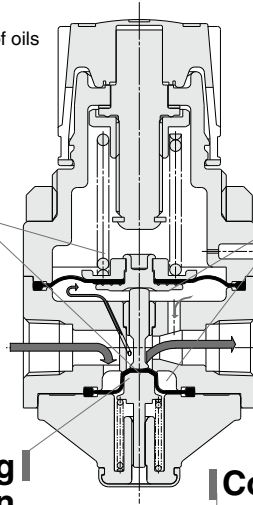

### Designed to minimize residual fluid

- Design includes an intake/exhaust port in the diaphragm compartment which facilitates flow
- Valve springs are partitioned by the diaphragm

### Pulsation suppressing design

#### Step response comparison

SRH

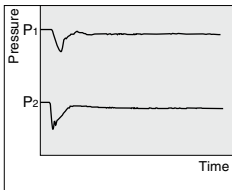

Current regulator

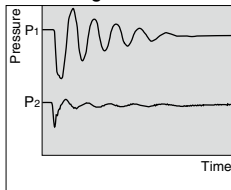

#### Circuit diagram

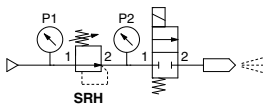

### Consistent clean room production

Washed, assembled and inspected in a Class 100 environment, and sealed in double bags

#### Manufacturing process

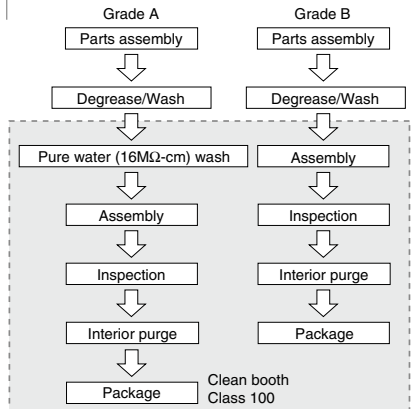

# Clean Regulator

# SRH Series

RoHS



## How to Order

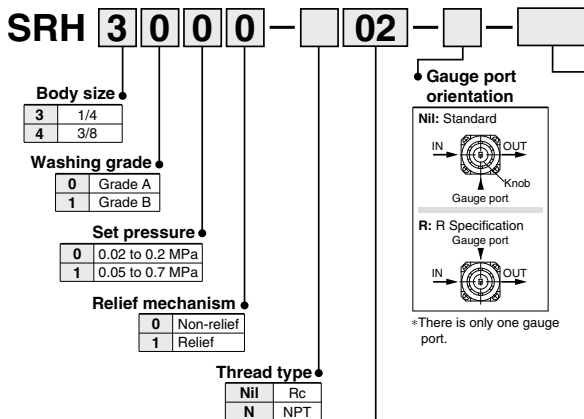

Symbol	Piping port size	Port size	
		SRH3000	SRH4000
01	1/8	●	—
02	1/4	●	●
03	3/8	—	●
04	1/2	—	●
A2	With metal gasket seal fitting	URJF 1/4	—
A3	With metal gasket seal fitting	—	URJF 3/8

Made to Order

Refer to pages 864 to 866 for details.

X210	EPDM seals
X211	With relief port fittings (Applicable tube O.D.: ø4)
X216	Machined relief port M5 thread
X233	Knob operation product with reduced torque
X234	Aluminum body

Note) The pressure gauge is optional. Refer to option specifications on page 862.  
Note that the products used for the port size A2 or A3 are not available at SMC.

## Specifications

Model		SRH3□□0	SRH4□□0	SRH3□□1	SRH4□□1
Relief mechanism		Non-relief		Relief	
Port size		1/8, 1/4 URJF 1/4	1/4, 3/8, 1/2 URJF 3/8	1/8, 1/4	1/4, 3/8, 1/2
Fluid	Grade A	Clean air, N <sub>2</sub> , Ar, CO <sub>2</sub> , Pure water		Clean air, N <sub>2</sub>	
	Grade B	Air, N <sub>2</sub> , Ar, CO <sub>2</sub> , Water		Air, N <sub>2</sub>	
Proof pressure		1.5 MPa			
Max. operating pressure		1 MPa			
Set pressure	Low pressure type	0.02 to 0.2 MPa			
	High pressure type	0.05 to 0.7 MPa			
Ambient and fluid temperatures		0 to 60°C (No freezing)			
Fluid-contact material (metal)		Stainless steel 316 (Body is stainless steel 316L)			
Diaphragm material	Grade A	PTFE			
	Grade B	Fluororubber			
Weight		360 g	730 g	360 g	730 g

ARJ  
AR425 to 935  
ARX  
AMR  
ARM  
ARP  
IR□-A  
IR  
IRV  
VEX  
SRH  
SRP  
SRF  
ITV  
IC  
ITVH  
ITVX  
PVQ  
VY1  
VBA  
VBAT  
AP100

## Flow Rate Characteristics (Representative Value)

**Fluid: Air**

Conditions/ Inlet pressure: 0.5 MPa

**SRH3000-02**

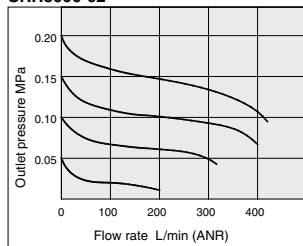

**SRH3100-02**

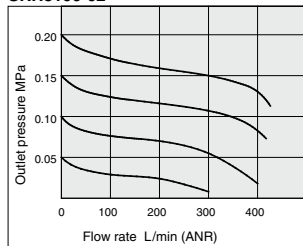

**SRH4000-03**

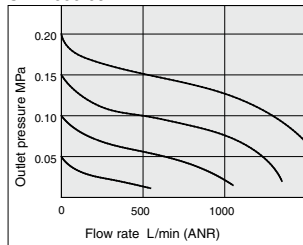

**SRH4100-03**

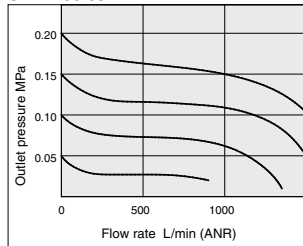

Conditions/ Inlet pressure: 0.7 MPa

**SRH3010-02**

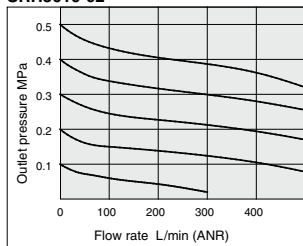

**SRH3110-02**

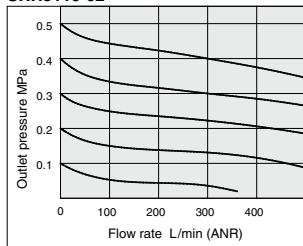

**SRH4010-03**

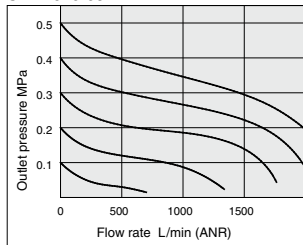

**SRH4110-03**

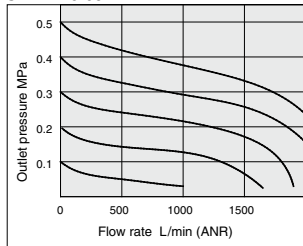

**Fluid: Water**

Conditions/ Inlet pressure: 0.5 MPa

**SRH3000-02**

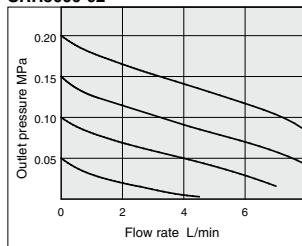

**SRH3100-02**

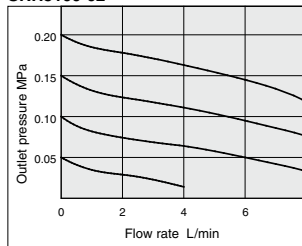

**SRH4000-03**

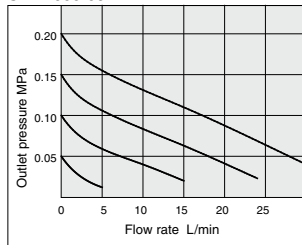

**SRH4100-03**

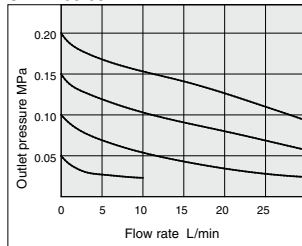

**Pressure Characteristics (Representative Value)**

**Fluid: Water/Air**

Conditions/ Inlet pressure: 0.7 MPa

**SRH3010-02**

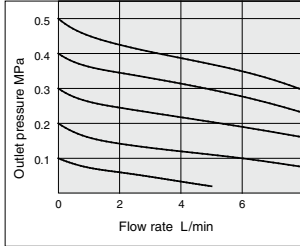

**SRH3110-02**

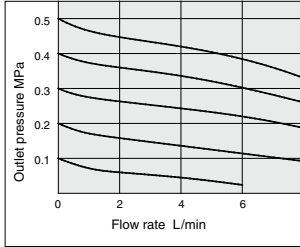

**SRH4010-03**

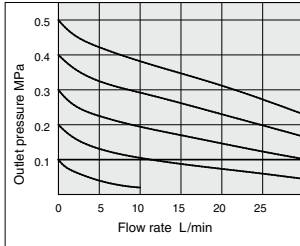

**SRH4110-03**

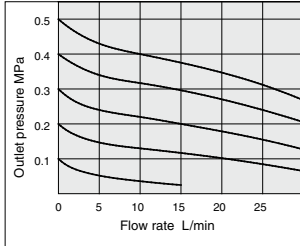

Conditions/ Inlet pressure: 0.7 MPa, Outlet pressure: 0.2 MPa, Flow rate 2 L/min

**SRH3000**

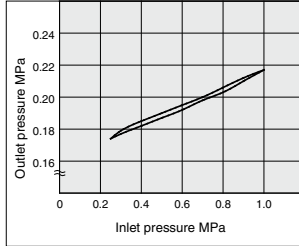

**SRH4000**

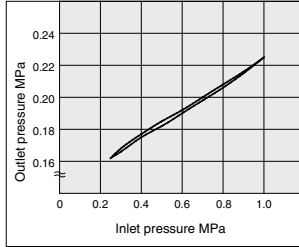

**SRH3100**

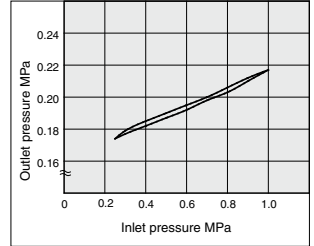

**SRH4100**

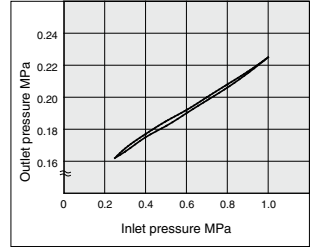

ARJ

AR425  
to 935

ARX

AMR

ARM

ARP

IR□-A

IR

IRV

VEV

**SRH**

SRP

SRF

ITV

IC

ITVH

ITVX

PVQ

VY1

VBA  
VBAT

AP100

# SRH Series

## Construction

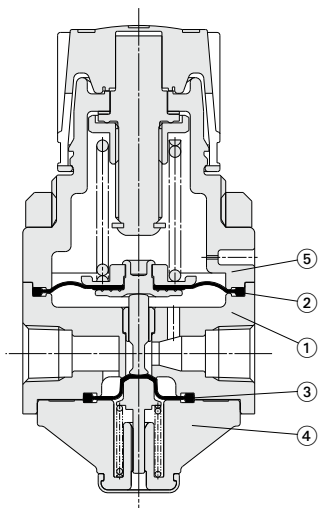

### Component parts

No.	Description	Material	
		Grade A	Grade B
1	<b>Body</b>	Stainless steel 316L	
2	<b>Diaphragm</b>	PTFE	Fluororubber
3	<b>Diaphragm</b>	PTFE	Fluororubber
4	<b>Valve guide</b>	PPS	
5	<b>Bonnet</b>	PPS	

**Dimensions**

**Rc thread type**

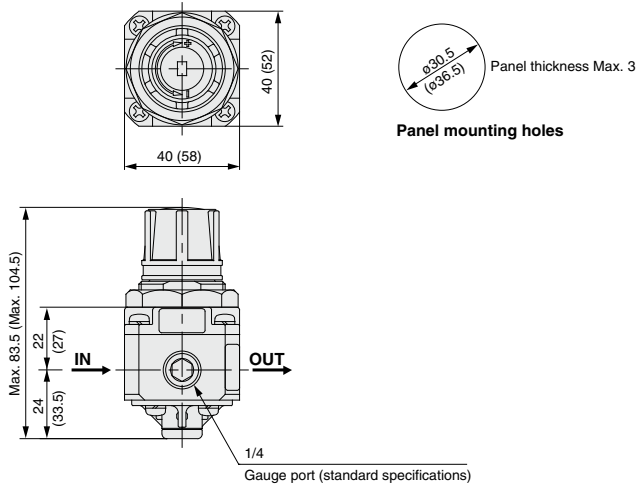

Dimensions inside ( ) are for SRH4000.

**Metal gasket seal fitting type**

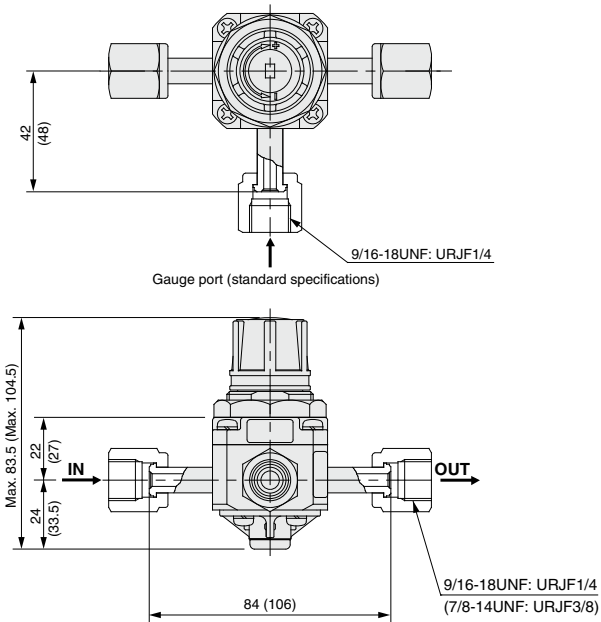

Dimensions inside ( ) are for SRH4000.

ARJ
AR425 to 935
ARX
AMR
ARM
ARP
IR□-A
IR
IRV
VEX
<b>SRH</b>
SRP
SRF
ITV
IC
ITVH
ITVX
PVQ
VY1
VBA
VBAT
AP100

## Options

### Pressure Gauge

#### Dimensions

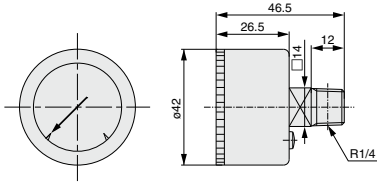

#### Specifications

Item	Model	G46-□-02-SRA	G46-□-02-SRB
Port size		R 1/4	
Operating temperature range		0 to 60°C (No freezing)	
Accuracy		± 3%F.S.	
Scale range		270°	
Parts washing (fluid-contact parts)		Precision wash	General degrease
Assembly and adjustment environment		Clean room	General production line
Oil free / Water free		Non-lube / Non-wet	
Materials	Fluid-contact parts	Stainless steel 316	
	Case	Stainless steel 304 (Black melamine coating)	
	Clear cover	Polycarbonate (Hard coated) Part No. G46-00-00-2	
	Internal parts	Brass	
Weight		80 g	

#### Models

Model	Pressure range	Indicator units
	MPa	
G46-2-02-SRA	0 to 0.2	MPa
G46-2-02-SRB		
G46-4-02-SRA	0 to 0.4	
G46-4-02-SRB		
G46-7-02-SRA	0 to 0.7	
G46-7-02-SRB		
G46-10-02-SRA	0 to 1.0	
G46-10-02-SRB		

#### Procedure for setting the limit gauge indicator

- 1) Before setting the limit indicator, turn the cover counterclockwise (approximately 6 to 7 mm) until it stops. Then, remove by pulling it towards you.

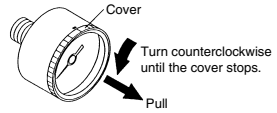

- 2) Use a flat head screwdriver (with a 2.9 mm blade width) to set the limit indicator. Be careful not to bend other needle or damage the dial plate.

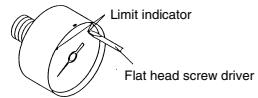

- 3) After completing the setting, replace the cover. Fit the cover by aligning the cutout in the cover to the groove on the top of the black case. Turn the cover clockwise (approximately 6 to 7 mm) and make sure that the matching mark on the cover is aligned with the groove on the top of the case.

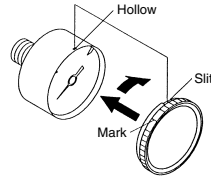

#### ⚠ Specific Product Precautions

Be sure to read this before handling the products. Refer to back page 50 for Safety Instructions and pages 387 to 391 for Precautions on every series.

#### Selection

#### ⚠ Caution

- 1) Avoid use in locations with strong pressure pulsation or vibration.
- 2) Contact SMC if the product is to be used in an application with a high frequency of operation.

#### Mounting

#### ⚠ Caution

- 1) Do not subject the gauge to shocks, such as dropping during transportation and mounting, as this can cause loss of indication accuracy.
- 2) Do not use this gauge in a location with high temperature and humidity, as this may cause faulty operation.
- 3) When mounting the pressure gauge, be certain to use a wrench on the square wrench flats to screw it into place. If the wrench is applied on any other part, air leakage or other damage may occur.



**Brackets**

	For SRH3000	For SRH4000
Model	B21-1-T1	1350112-T1
Material	Rolled sheet steel (Electroless nickel plated)	
Dimensions		

ARJ

AR425  
to 935

ARX

AMR

ARM

ARP

IR□-A

IR

IRV

VEX

**SRH**

SRP

SRF

ITV

IC

ITVH

ITVX

PVQ

VY1

VBA  
VBAT

AP100

# SRH Series Made to Order Specifications 1

Please contact SMC for detailed dimensions, specifications and lead times.



## 1 EPDM Seals Symbol **X210**

Regulator with seals made of a different material.

SRH Standard model no. — **X210**

↓ EPDM seals

### Specifications

Model		SRH3□□□-X210	SRH4□□□-X210	SRH3□□□-X210	SRH4□□□-X210
Relief mechanism		Non-relief		Relief	
Port size		1/8, 1/4 URJF 1/4	1/4, 3/8, 1/2 URJF 3/8	1/8, 1/4	1/4, 3/8, 1/2
Fluid	Grade A	Clean air, N <sub>2</sub> , Ar, CO <sub>2</sub> , Pure water		Clean air, N <sub>2</sub>	
	Grade B	Air, N <sub>2</sub> , Ar, CO <sub>2</sub> , Water		Air, N <sub>2</sub>	
Proof pressure		1.5 MPa			
Max. operating pressure		1.0 MPa			
Set pressure	Low pressure type	0.02 to 0.2 MPa			
	High pressure type	0.05 to 0.7 MPa			
Ambient and fluid temperatures		0 to 60°C (No freezing)			
Fluid-contact material (metal)		Stainless steel 316 (Body is stainless steel 316L)			
Diaphragm material	Grade A	PTFE			
	Grade B	EPDM			
Weight		360 g	730 g	360 g	730 g

## 2 With Relief Port Fittings (Applicable tube O.D.: ø4) Symbol **X211**

Regulator with a fitting in order to connect it to the relief port.

SRH Standard model no. — **X211**

↓ Made to Order ↓

Nil	Standard
<b>X211</b>	With relief port fittings (Applicable tube O.D.: ø4)

### Specifications

Model		SRH3□□□-X211	SRH4□□□-X211	SRH3□□□-X211	SRH4□□□-X211
Relief mechanism		Non-relief		Relief	
Port size		1/8, 1/4 URJF 1/4	1/4, 3/8, 1/2 URJF 3/8	1/8, 1/4	1/4, 3/8, 1/2
Fluid	Grade A	Clean air, N <sub>2</sub> , Ar, CO <sub>2</sub> , Pure water		Clean air, N <sub>2</sub>	
	Grade B	Air, N <sub>2</sub> , Ar, CO <sub>2</sub> , Water		Air, N <sub>2</sub>	
Proof pressure		1.5 MPa			
Max. operating pressure		1.0 MPa			
Set pressure	Low pressure type	0.02 to 0.2 MPa			
	High pressure type	0.05 to 0.7 MPa			
Ambient and fluid temperatures		0 to 60°C (No freezing)			
Fluid-contact material (metal)		Stainless steel 316 (Body is stainless steel 316L)			
Diaphragm material	Grade A	PTFE			
	Grade B	Fluororubber			
Weight		360 g	730 g	360 g	730 g

## Dimensions

Dimensions other than below are the same as the standard type.

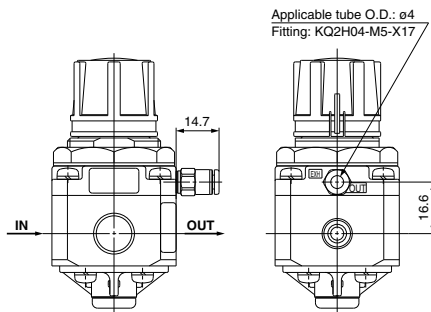

# SRH Series Made to Order Specifications 2

Please contact SMC for detailed dimensions, specifications and lead times.



## 3 Machined Relief Port M5 Thread **X216**

Regulator with an M5 thread machined on the relief port in order to connect it to the relief port.

SRH  Standard model no. — **X216**

↓ Made to Order

Nil	Standard
<b>X216</b>	Machined relief port M5 thread

### Specifications

Model	SRH3□□□-X216	SRH4□□□-X216	SRH3□□□-X216	SRH4□□□-X216
Relief mechanism	Non-relief		Relief	
Port size	1/8, 1/4 URJF 1/4	1/4, 3/8, 1/2 URJF 3/8	1/8, 1/4	1/4, 3/8, 1/2
Fluid	Grade A	Clean air, N <sub>2</sub> , Ar, CO <sub>2</sub> , Pure water	Clean air, N <sub>2</sub>	
	Grade B	Air, N <sub>2</sub> , Ar, CO <sub>2</sub> , Water	Air, N <sub>2</sub>	
Proof pressure	1.5 MPa			
Max. operating pressure	1.0 MPa			
Set pressure	Low pressure type	0.02 to 0.2 MPa		
	High pressure type	0.05 to 0.7 MPa		
Ambient and fluid temperatures	0 to 60°C (No freezing)			
Fluid-contact material (metal)	Stainless steel 316 (Body is stainless steel 316L)			
Diaphragm material	Grade A	PTFE		
	Grade B	Fluororubber		
Weight	360 g	730 g	360 g	730 g

### Dimensions

Dimensions other than below are the same as the standard type.

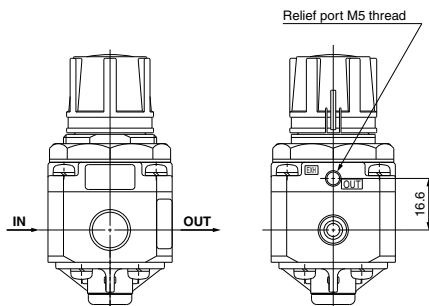

## 4 Knob Operation Product with Reduced Torque **X233**

Fluoro grease is applied to an adjusting screw in order to make the knob operation easy.

\* Oil is not used for the wetted parts.

SRH  Standard model no. — **X233**

↓ Knob Operation Product with Reduced Torque

### Specifications

Model	SRH3□□□-X233	SRH4□□□-X233	SRH3□□□-X233	SRH4□□□-X233
Relief mechanism	Non-relief		Relief	
Port size	1/8, 1/4 URJF 1/4	1/4, 3/8, 1/2 URJF 3/8	1/8, 1/4	1/4, 3/8, 1/2
Fluid	Grade A	Clean air, N <sub>2</sub> , Ar, CO <sub>2</sub> , Pure water	Clean air, N <sub>2</sub>	
	Grade B	Air, N <sub>2</sub> , Ar, CO <sub>2</sub> , Water	Air, N <sub>2</sub>	
Proof pressure	1.5 MPa			
Max. operating pressure	1.0 MPa			
Set pressure	Low pressure type	0.02 to 0.2 MPa		
	High pressure type	0.05 to 0.7 MPa		
Ambient and fluid temperatures	0 to 60°C (No freezing)			
Fluid-contact material (metal)	Stainless steel 316 (Body is stainless steel 316L)			
Diaphragm material	Grade A	PTFE		
	Grade B	Fluororubber		
Weight	360 g	730 g	360 g	730 g

## 5 Aluminum Body **X234**

The body material has been changed to aluminum.

SRH  Standard model no. — **X234**

↓ Aluminum Body

### Specifications

Model	SRH3□□□-X234	SRH4□□□-X234	SRH3□□□-X234	SRH4□□□-X234
Relief mechanism	Non-relief		Relief	
Port size	1/8, 1/4	1/4, 3/8, 1/2	1/8, 1/4	1/4, 3/8, 1/2
Fluid	Grade B	Air, N <sub>2</sub> , Ar, CO <sub>2</sub>	Air, N <sub>2</sub>	
Proof pressure	1.5 MPa			
Max. operating pressure	1.0 MPa			
Set pressure	Low pressure type	0.02 to 0.2 MPa		
	High pressure type	0.05 to 0.7 MPa		
Ambient and fluid temperatures	0 to 60°C (No freezing)			
Fluid-contact material (metal)	A2017 (Surface treatment: Anodized)			
Diaphragm material	Grade B	Fluororubber		
Weight	230 g	360 g	230 g	360 g

# SRH Series Made to Order Specifications 3



Please contact SMC for detailed dimensions, specifications and lead times.

## 6 Regulator (Stainless Steel 316) with Port Sizes Rc 3/4, Rc 1

- Regulator made of stainless steel 316 with port sizes Rc 3/4 and Rc 1.
  - EPDM or FPM is used for valves (seals), O-rings and diaphragms.
  - Oil-free
- Oil is not used for any of the parts and all wetted parts are degreased.
- Note) Products must be assembled under normal conditions.

### Specifications

Model	XT13-394-06	XT13-394-10	INA-48-1-06	INA-48-1-10	INA-48-58-06-H	INA-48-58-10-H	INA-48-16-06	INA-48-16-10
Port size	Rc3/4	Rc1	Rc3/4	Rc1	Rc3/4	Rc1	Rc3/4	Rc1
Relief mechanism	Non-relief				Relief		Non-relief	
Fluid	Deionized water (Pure water)				Air, N <sub>2</sub>			
Proof pressure					1.5 MPa		1.9 MPa	
Max. operating pressure					1.0 MPa		1.3 MPa	
Set pressure					0.05 to 0.5 MPa		0.1 to 1.0 MPa	
Ambient and fluid temperatures	5 to 60°C							
Fluid-contact material (metal)	Stainless steel 316							
Diaphragm material	EPDM				Fluororubber			
Weight	2100 g							

Note) The pressure gauge is optional. For details, refer to the Options on page 862.

### Flow Rate Characteristics

#### XT13-394-06, 10

--- Max. operating flow rate  
(It is recommended to be used within the max. operating flow rate (negative) range.)

Conditions/ Inlet pressure: 0.5 MPa, Fluid: Water

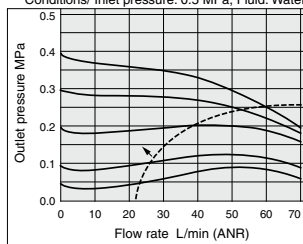

#### INA-48-1-06, 10

Conditions/ Inlet pressure: 0.55 MPa, Fluid: Air

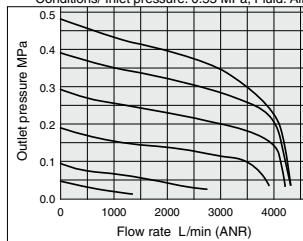

### Construction

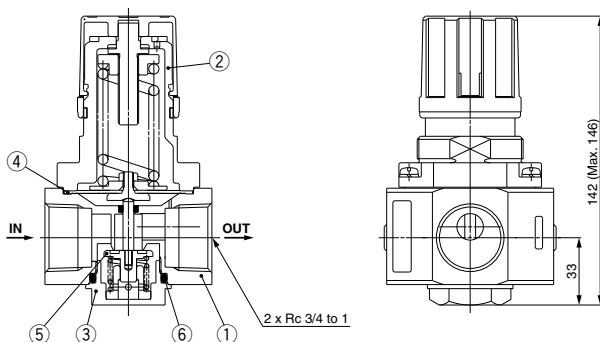
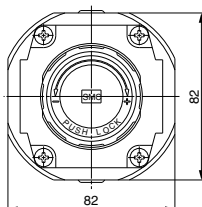

### Component parts

No.	Description	Material	
		XT13-394-06, 10	INA-48-1-06, 10
1	Body	Stainless steel 316	
2	Bonnet	ADC12	
3	Valve guide	Stainless steel 316	
4	Diaphragm Assembly	EPDM Stainless steel 316 (Wetted part metal)	Fluororubber Stainless steel 316 (Wetted part metal)
5	Valve	EPDM (Seals) Stainless steel 316 (Wetted part metal)	FPM (Seals) Stainless steel 316 (Wetted part metal)
6	O-ring	EPDM Fluororubber	



# SRH Series

## Specific Product Precautions

Be sure to read this before handling the products.

Refer to back page 50 for Safety Instructions and pages 387 to 391 for Precautions on every series.

### Design and Selection

#### Warning

##### 1. Confirm the fluid.

Because the fluid to be used differs depending on the product, be certain to confirm the specifications. If an incompatible fluid is used, special characteristics will change and this may cause improper operation.

##### 2. Residual pressure relief is not possible without inlet pressure.

In the SRH series, if the inlet pressure is cut off while pressure still remains on the outlet side, it is not possible to eliminate the outlet pressure (residual pressure relief). If it will be necessary to eliminate pressure from the outlet side, a circuit should be provided for residual pressure relief.

#### Caution

##### 1. Oscillation (beat) may occur with some operating conditions even if the operation is within specification. Contact SMC for that case.

##### 2. When operating at an inlet pressure lower than the inlet pressure used in the flow rate characteristics graph, the pressure drop on the outlet side may be greater. Therefore, be sure to conduct testing using the actual equipment.

For pressure control equipment selection, refer to page 123 in the "Product Selection Guide."

### Mounting

#### Caution

##### 1. Open the sealed package inside a clean room.

These products are packaged in sealed double packaging in a clean room. It is recommended that the inside packaging be opened in a clean room or other clean environment.

##### 2. Flush out the piping.

Connect these products to piping only after it has been flushed and cleaned properly. If debris or scale etc. remains in the piping, this can cause faulty operation or failure.

##### 3. Be certain that sealing material does not get inside the piping.

When screwing in pipes and joints etc., take care that cutting dust from the pipe threads, sealing material, and the like do not get inside the piping. If debris or scale etc. remain inside the piping, this may cause faulty operation or failure. Also, when thread tape is used, leave 1.5 to 2 threads exposed at the end of the pipe.

##### 4. Confirm the mounted orientation of the product.

The side marked IN is the fluid inlet port, and the side marked OUT is the fluid exhaust port. If mounted backwards, the device will not operate properly.

### Pressure Adjustment

#### Warning

##### 1. Do not use tools when operating the pressure regulator knob.

If tools etc. are used to operate the pressure regulator knob, damage may occur. Operate this knob only by hand.

#### Caution

##### 1. Perform pressure adjustments only after releasing the lock.

When the pressure regulator knob will not turn, it is locked. Release the lock by pulling the pressure regulator knob out. If the knob is turned by force damage will occur.

Lock again after adjusting the pressure by pressing the knob back down.

##### 2. Adjust pressure in an upward direction.

A correct pressure setting cannot be achieved by adjusting the pressure downward. The outlet pressure is increased by turning the pressure regulator knob to the right, and decreased by turning the knob to the left.

##### 3. In the case of the non-relief type, the pressure cannot be reduced by turning the pressure regulator knob to the left.

In the case of the non-relief type regulator, the outlet pressure will not decrease even if the knob is turned to the left, when there is no outlet fluid consumption. The knob will be damaged if it is turned by force.

In case the pressure setting is too high, reduce the pressure on the outlet side to less than the desired setting pressure by consuming fluid on the outlet side, and then reset to the desired pressure.

##### 4. Confirm the inlet pressure.

Set the outlet pressure to no more than 85% of the inlet pressure. If the inlet pressure is too low, a correct setting pressure cannot be attained.

##### 5. Do not use fluid containing solid matter.

This will cause faulty operation.

ARJ

AR425  
to 935

ARX

AMR

ARM

ARP

IR□-A

IR

IRV

VEX

SRH

SRP

SRF

ITV

IC

ITVH

ITVX

PVQ

VY1

VBA  
VBAT

AP100