

Soft Start-up Valve

AV2000/3000/4000/5000 Series

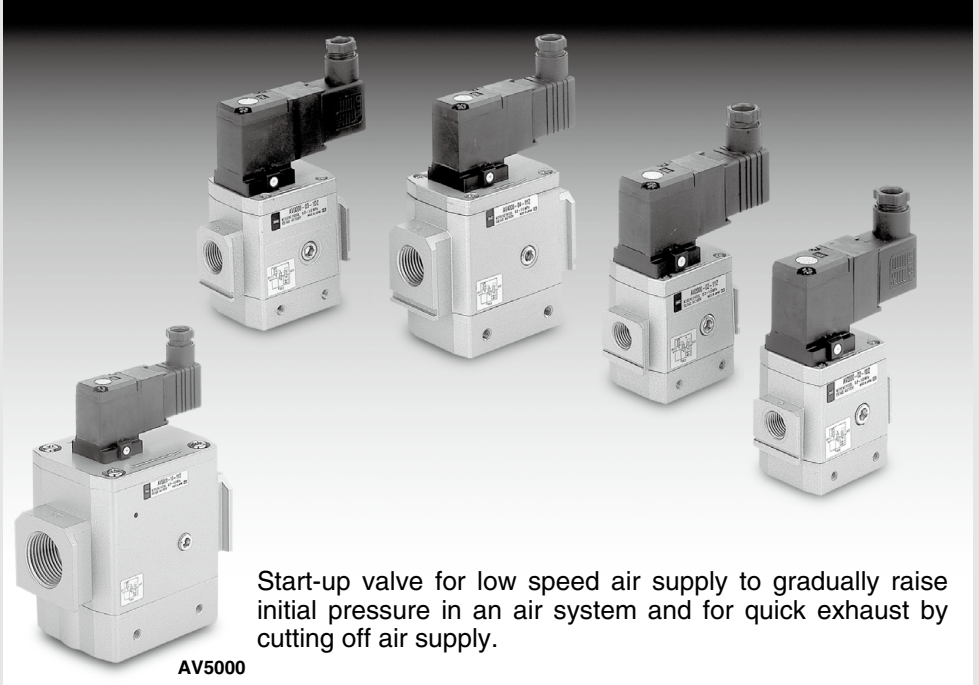

AV5000

Start-up valve for low speed air supply to gradually raise initial pressure in an air system and for quick exhaust by cutting off air supply.

| |
|-----------|
| AC-A |
| AF-A |
| AF□-A |
| AR-A |
| AL-A |
| AW-A |
| AC-B |
| AF-A |
| AF□-A |
| AR-B |
| AL-A |
| AW-B |
| AW□ |
| AW□G |
| E□ |
| AV |
| AF |

Large effective area (mm²)

| | |
|---------|----------------------|
| AV2000/ | 20 (Body size: 1/4) |
| AV3000/ | 37 (Body size: 3/8) |
| AV4000/ | 61 (Body size: 1/2) |
| AV5000/ | 113 (Body size: 3/4) |
| AV5000/ | 122 (Body size: 1) |

With supply/exhaust function by manual operation

Low power consumption

Connectable with modular type F.R.L. combination unit

Combination with F.R.L. unit

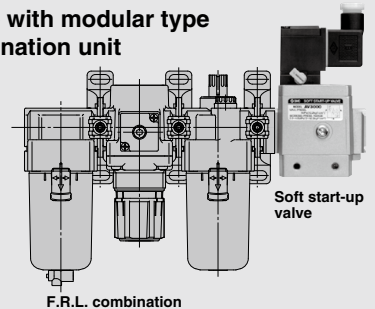
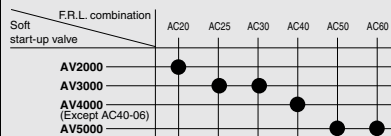

F.R.L. combination

Soft Start-up Valve

AV2000/3000/4000/5000

How to Order

AV 20 00 - 02 - 1 G - - -

Soft start-up valve

Body size

| | |
|----|--------|
| 20 | 1/4 |
| 30 | 3/8 |
| 40 | 1/2 |
| 50 | 3/4, 1 |

Thread type

| | |
|-----|-----|
| Nil | Rc |
| F | G |
| N | NPT |

Port size

| | |
|----|-------------------|
| 02 | 1/4 (AV2000 only) |
| 03 | 3/8 (AV3000 only) |
| 04 | 1/2 (AV4000 only) |
| 06 | 3/4 (AV5000 only) |
| 10 | 1 (AV5000 only) |

Option

| | |
|-----|---------------------|
| Nil | None |
| G | With pressure gauge |

CE/UKCA-compliant

| | |
|-----|---------------------------|
| Nil | |
| Q | CE/UKCA-Compliant Note 2) |

Note 2) "G", grommet is not available.

Flow direction

| | |
|-----|---------------|
| Nil | Left to right |
| R | Right to left |

Manual override

| | |
|------|-------------------------------|
| Nil: | Non-locking push type (Flush) |
| B: | Locking type (Tool required) |
| C: | Locking type (Lever) |

Light/Surge voltage suppressor

| | |
|-----|--|
| Nil | None |
| S | With surge voltage suppressor (Grommet type only) |
| Z | With light/surge voltage suppressor (Not possible with grommet type) |

Coil rated voltat

| | |
|---|---------------------------|
| 1 | 100 VAC (50/60 Hz) |
| 2 | 200 VAC (50/60 Hz) |
| 3 | 110 to 120 VAC (50/60 Hz) |
| 4 | 220 VAC (50/60 Hz) |
| 5 | 24 VDC |
| 6 | 12 VDC |
| 7 | 240VAC (50/60 Hz) |

For other rated voltages, please consult with SMC.

Electrical entry

| | | |
|-----|---|-------------------|
| G: | Grommet (Note 1) | CE/UKCA-compliant |
| D: | Type D DIN terminal (With connector) | |
| DO: | Type D DIN terminal (Without connector) | |
| Y: | Type Y DIN terminal (With connector) | |
| YO: | Type Y DIN terminal (Without connector) | |

How to Order Pilot Valve Assembly

SF4 - 1 G - - - 80 - - -

Rated coil voltage

| | |
|---|---------------------------|
| 1 | 100 VAC (50/60 Hz) |
| 2 | 200 VAC (50/60 Hz) |
| 3 | 110 to 120 VAC (50/60 Hz) |
| 4 | 220 VAC (50/60 Hz) |
| 5 | 24 VDC |
| 6 | 12 VDC |
| 7 | 240 VAC (50/60 Hz) |

For other rated voltages, please consult with SMC.

Soft start-up valve

CE/UKCA-compliant

| | |
|-----|---------------------------|
| Nil | - |
| Q | CE/UKCA-Compliant Note 2) |

Note 2) "G", grommet is not available.

Flow direction

| | |
|-----|---------------|
| Nil | Left to right |
| R | Right to left |

Manual override

| | |
|-----|------------------------------------|
| Nil | Non-locking push type (Flush type) |
| B | Locking type (Tool required) |
| C | Locking type (Lever type) |

Light/Surge voltage suppressor

| | |
|-----|--|
| Nil | None |
| S | With surge voltage suppressor (Grommet type only) |
| Z | With light/surge voltage suppressor (Not possible with grommet type) |

Electrical entry

| | | |
|----|---|-------------------|
| G | Grommet (Note 1) | CE/UKCA-compliant |
| D | Type D DIN terminal (With connector) | |
| Y | Type Y DIN terminal (With connector) | |
| DO | Type D DIN terminal (Without connector) | |
| YO | Type Y DIN terminal (Without connector) | |

Note 1) The grommet type can have a surge voltage suppressor (direct coupling type lead wire), but without indicator light.

Specifications



Type D DIN terminal



Type Y DIN terminal

| Model | AV2000 | AV3000 | AV4000 | AV5000 | | |
|-----------------------------------|---|---|--|--------|------|--|
| Port size | 1/4 | 3/8 | 1/2 | 3/4 | 1 | |
| Proof pressure | 1.5 MPa | | | | | |
| Operating pressure range | 0.2 to 1 MPa | | | | | |
| Pressure gauge port size | 1/8 | | | | | |
| Ambient and fluid temperature | 0 to 60°C ⁽¹⁾ | | | | | |
| Effective area (mm ²) | 1(P) → 2(A) | 20 | 37 | 61 | 113 | |
| | 2(A) → 3(R) | 24 | 49 | 76 | 132 | |
| Weight (kg) | 0.27 | 0.48 | 0.74 | 1.60 | 1.54 | |
| Electrical specifications | Rated coil voltage | 100, 200, 110 to 120, 220 VAC (50/60 Hz), 240 VAC (50/60 Hz) 12, 24 VDC | | | | |
| | Allowable voltage fluctuation | -15 to +10% of rated voltage | | | | |
| | Coil insulation type | Equivalent to B type (130°C) | | | | |
| | Apparent power (Current consumption) AC | Inrush | 5.6 VA (50 Hz), 5.0 VA (60 Hz) | | | |
| | | Energized | 3.4 VA (2.1 W)/50 Hz, 2.3 VA (1.5 W)/60 Hz | | | |
| | Current consumption DC | 1.8 W | | | | |
| Electrical entry | Grommet, Type D DIN terminal, Type Y DIN terminal | | | | | |
| Option specifications | Indicator light/Surge voltage suppressor ⁽²⁾ | | | | | |
| Pilot valve manual override | Non-locking push type (Flush), Locking type (Tool required), Locking type (Lever) | | | | | |

Note 1) Use dry air when operating at a low temperature.

Note 2) The grommet type is equipped with a surge voltage suppressor (direct coupling type lead wire), but not an indicator light.

Piston B Switching Pressure (Close → Open)

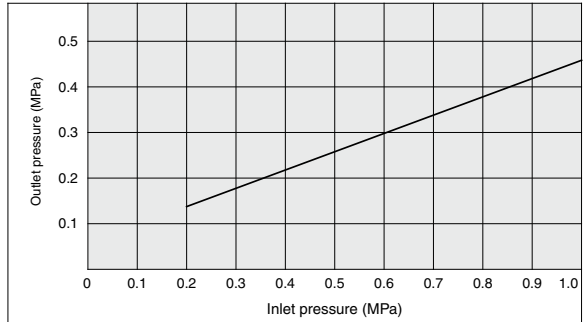

Symbol

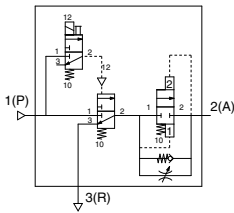

Accessory/Pressure Gauge

| | |
|----------------|----------------|
| Description | Pressure gauge |
| Part no. | G36-10-01 |
| Pressure range | 1 MPa |

Needle Valve Flow Rate Characteristics

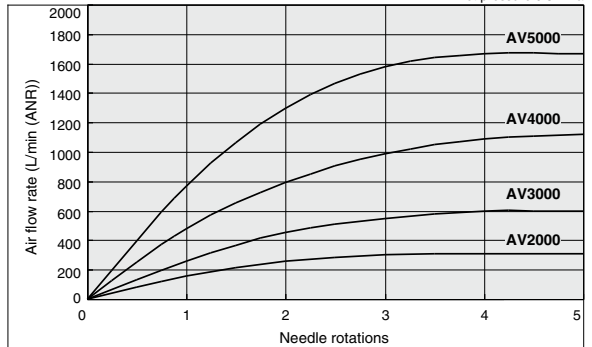

AV2000/3000/4000/5000 Series

Working Principle

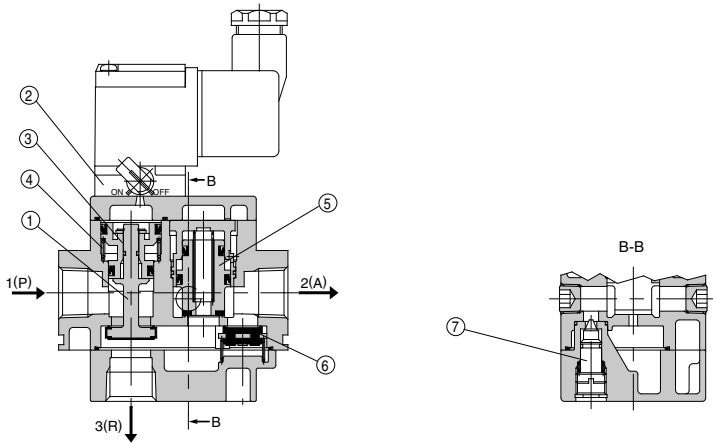

| Working condition | Pilot valve | Pressure conditions | Working description | Pressure time chart (Meter-out control) example | Cylinder drive circuit (Meter-out control) example | |
|-------------------|-------------|---------------------|--|---|--|--|
| Low speed supply | ON | $1/2 P_p > P_A$ | When pilot valve ② is turned ON by energization or manual override, the pilot air pushes piston A ③ and main valve ① downward and opens main valve ⑦ while R port closes simultaneously. The air from P port moves to needle valve ⑦, where its flow is adjusted, and flows to A port. The meter-in control of needle valve ⑦ slowly moves the cylinder from ① to ②. | <p>Initial Operation Return Stroke</p> | | |
| High speed supply | | $1/2 P_p \leq P_A$ | When $1/2 P_p \leq P_A$ after the cylinder reaches ②, piston B ⑤ fully opens and P_A increases rapidly as shown from ③ to ④ and becomes the same pressure as P_p . | | | |
| Normal operation | | $P_p \approx P_A$ | Since piston B ⑤ holds the fully open condition, during normal operation the cylinder's speed will be controlled by the usual meter-out control. | | | |
| Quick exhaust | OFF | — | When pilot valve ② is turned OFF, spring ④ pushes piston A ③ and main valve ① upward and opens R port while shutting off the air supply from P port. The pressure difference generated at this time lets the check valve ⑥ open and the residual pressure on the A port side is quickly exhausted from R port. | | | |

Construction

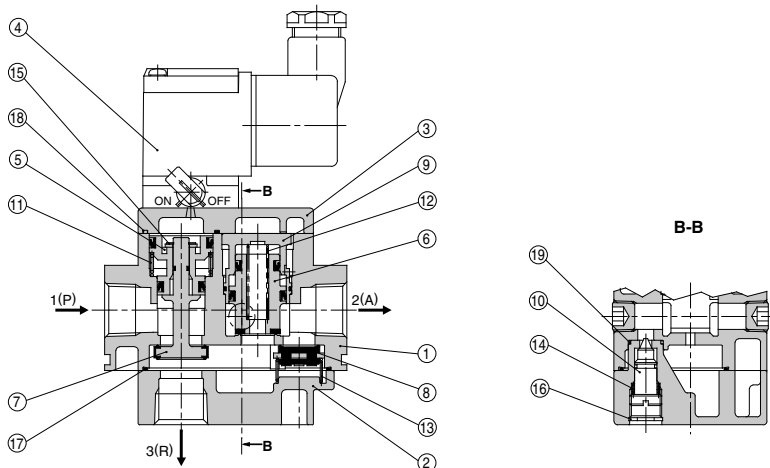

Component Parts

| No. | Description | Material |
|-----|-------------|---------------------|
| 1 | Body | Aluminum die-casted |
| 2 | Cap | Aluminum die-casted |
| 3 | Cover | Aluminum die-casted |

Replacement Parts

| No. | Description | Material | Part no. | | | |
|-----|---------------------------------|-------------------|-----------------------------|------------|------------------|-----------------|
| | | | AV2000 | AV3000 | AV4000 | AV5000 |
| 4 | Pilot valve assembly | — | SF4-□-80 ^{*1} (-Q) | | | |
| 5 | Piston A assembly | POM, NBR | P424204A | P424304A | P424404A | P424504A |
| 6 | Piston B assembly | Brass, NBR (HNBR) | P424205A | P424305A | P424405A | P424505A |
| 7 | Main valve assembly | Brass, NBR (HNBR) | P424206A | P424306A | P424406A | P424506A |
| 8 | Check valve | Brass, NBR (HNBR) | P424207 | P424307 | P424407 | P424507 |
| 9 | Piston guide assembly | POM, NBR | P424208A | P424308A | P424408A | P424508A |
| 10 | Needle assembly | Brass, NBR | P424209A | P424309A | P424409A | P424509A |
| 11 | Valve spring | Steel wire | P424211 | P424311 | P424411 | P424511 |
| 12 | Piston spring | Stainless steel | P424212 | P424312 | P424412 | P424512 |
| 13 | Check spring | Stainless steel | P424213 | P424313 | P424413 | P424513 |
| 14 | Needle spring | Steel wire | P424214 | P424314 | P424414 | — |
| 15 | Type C retaining ring for shaft | Tool steel | G-5 | STW-5 | STW-8 | STW-10 |
| 16 | Type C retaining ring for hole | Tool steel | 0-9 | 0-10 | RTW-12 | RTW-15 |
| 17 | Seal | NBR | P424210 | P424310 | P424410 | P424510 |
| 18 | Seal | NBR | P424218 | P424315 | P424415 | P424514 |
| 19 | O-ring | NBR | 10 x 8 x 1 | 11 x 9 x 1 | 12.5 x 9.5 x 1.5 | 16.5 x 12.5 x 2 |

*1 For "How to Order" pilot valve assembly, refer to page 652.

- AC-A
- AF-A
- AF□-A
- AR-A
- AL-A
- AW-A
- AC-B
- AF-A
- AF□-A
- AR-B
- AL-A
- AW-B
- AW□
- A□G
- E□
- AV
- AF

AV2000/3000/4000/5000 Series

Dimensions

Grommet: AV□00-□-□G, GS

DIN terminal: AV□00-□-□DZ

DIN terminal for European use: AV□00-□-□Y, YZ

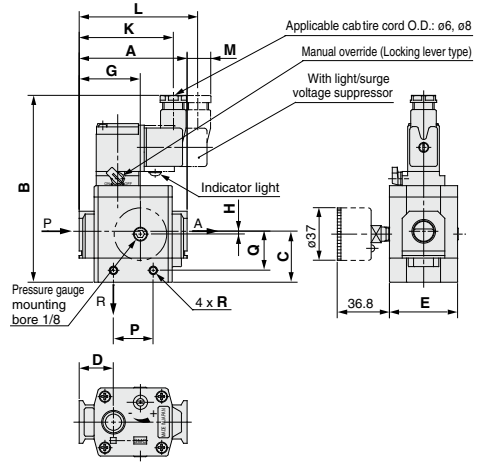
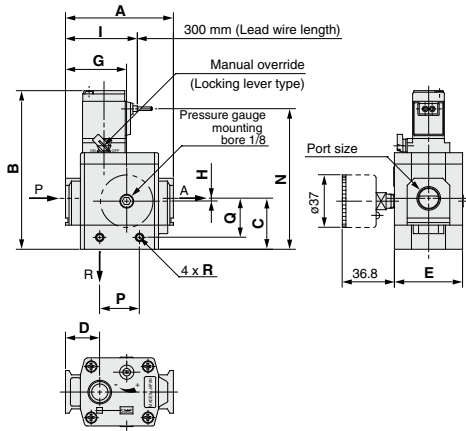

| Model | Port size | A | B | C | D | E | G | H | I | K | L | M | N | P | Q | R |
|---|-----------|-----|-----|----|----|----|----|---|------|------|------|------|-----|----|------|-----------------------|
| AV2000-□02-□G□ | 1/4 | 66 | 105 | 31 | 22 | 40 | 38 | 0 | 47.5 | — | — | — | 93 | 29 | 23.5 | M4 x 0.7 Depth 4.5 |
| AV2000-□02-□GS□ | | | | | | | | | | 65.5 | — | 6 | — | 29 | 23.5 | |
| AV2000-□02-□D□ | 1/4 | 66 | 125 | 31 | 22 | 40 | 38 | 0 | — | — | 80.5 | 23 | — | 29 | 23.5 | M4 x 0.7 Depth 4.5 |
| AV2000-□02-□DZ□ | | | | | | | | | | 67.5 | — | 10.5 | — | 29 | 23.5 | |
| AV2000-□02-□Y□ | 1/4 | 66 | 125 | 31 | 22 | 40 | 38 | 0 | — | — | 84.5 | 27.5 | — | 29 | 23.5 | M4 x 0.7 Depth 4.5 |
| AV2000-□02-□YZ□ | | | | | | | | | | — | — | — | — | — | — | |
| AV3000-□03-□G□ | 3/8 | 76 | 112 | 36 | 24 | 48 | 43 | 2 | 50.5 | — | — | — | 100 | 28 | 27.5 | M5 x 0.8 Depth 5 |
| AV3000-□03-□GS□ | | | | | | | | | | 66.5 | — | — | — | 28 | 27.5 | |
| AV3000-□03-□D□ | 3/8 | 76 | 132 | 36 | 24 | 48 | 43 | 2 | — | — | 83.5 | 16 | — | 28 | 27.5 | M5 x 0.8 Depth 5 |
| AV3000-□03-□DZ□ | | | | | | | | | | 70.5 | — | 3.5 | — | 28 | 27.5 | |
| AV3000-□03-□Y□ | 3/8 | 76 | 132 | 36 | 24 | 48 | 43 | 2 | — | — | 87.5 | 20.5 | — | 28 | 27.5 | M5 x 0.8 Depth 5 |
| AV3000-□03-□YZ□ | | | | | | | | | | — | — | — | — | — | — | |
| AV4000-□04-□G□ | 1/2 | 98 | 127 | 47 | 32 | 52 | 57 | 3 | 62.5 | — | — | — | 115 | 42 | 37 | M6 x 1 Depth 6 |
| AV4000-□04-□GS□ | | | | | | | | | | 78.5 | — | — | — | 42 | 37 | |
| AV4000-□04-□D□ | 1/2 | 98 | 147 | 47 | 32 | 52 | 57 | 3 | — | — | 95.5 | 6 | — | 42 | 37 | M6 x 1 Depth 6 |
| AV4000-□04-□DZ□ | | | | | | | | | | 82.5 | — | — | — | 42 | 37 | |
| AV4000-□04-□Y□ | 1/2 | 98 | 147 | 47 | 32 | 52 | 57 | 3 | — | — | 99.5 | 10.5 | — | 42 | 37 | M6 x 1 Depth 6 |
| AV4000-□04-□YZ□ | | | | | | | | | | — | — | — | — | — | — | |
| AV5000-□ ⁶ / ₁₀ -□G□ | 3/4, 1 | 128 | 155 | 59 | 39 | 74 | 77 | 0 | 74 | — | — | — | 143 | 50 | 46 | M6 x 1 Depth 7.5 |
| AV5000-□ ⁶ / ₁₀ -□GS□ | | | | | | | | | | 90 | — | — | — | 50 | 46 | |
| AV5000-□ ⁶ / ₁₀ -□D□ | 3/4, 1 | 128 | 175 | 59 | 39 | 74 | 77 | 0 | — | — | 107 | — | — | 50 | 46 | M6 x 1 Depth 7.5 |
| AV5000-□ ⁶ / ₁₀ -□DZ□ | | | | | | | | | | 94 | — | — | — | 50 | 46 | |
| AV5000-□ ⁶ / ₁₀ -□Y□ | 3/4, 1 | 128 | 175 | 59 | 39 | 74 | 77 | 0 | — | — | 111 | — | — | 50 | 46 | M6 x 1 Depth 7.5 |
| AV5000-□ ⁶ / ₁₀ -□YZ□ | | | | | | | | | | — | — | — | — | — | — | |

Connecting Spacer for Modular Type F.R.L. Unit

Select one of the spacers below when connecting to an F.R.L. combination unit (AC20 to AC60).
(Spacers must be ordered separately.)

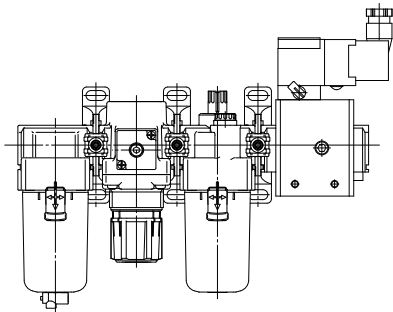

Spacer



Y200-A



Y400-A

| Model | Applicable model |
|---------------|------------------|
| Y200-A | AV2000 |
| Y300-A | AV3000 |
| Y400-A | AV4000 |
| Y600-A | AV5000 |

Spacer with bracket



Y200T-A



Y400T-A

| Model | Applicable model |
|----------------|------------------|
| Y200T-A | AV2000 |
| Y300T-A | AV3000 |
| Y400T-A | AV4000 |
| Y600T-A | AV5000 |

AC-A

AF-A

AF□-A

AR-A

AL-A

AW-A

AC-B

AF-A

AF□-A

AR-**B**

AL-A

AW-**B**

AW□

A□G

E□

AV

AF



AV2000/3000/4000/5000 Series Specific Product Precautions 1

Be sure to read this before handling the products.

Refer to back page 50 for Safety Instructions and pages 387 to 391 for F.R.L. Precautions.

Caution on Design

Warning

1. Actuator drive

When using solenoid valve or actuator in the outlet side of this product, implement appropriate measures to prevent potential danger caused by actuator operation.

2. Holding pressure

Since the valve might have slight internal leakage, it is not suitable for holding pressure in a tank or another vessel for a long period of time.

3. Maintenance space

Allow the sufficient space for maintenance and inspection.

Selection

Warning

1. Confirm the specifications.

The products presented in this catalog are designed only for use in compressed air systems. Do not operate at pressures or temperatures, etc., beyond the range of specifications, as this can causedamage or malfunction. (Refer to specifications.) Please contact SMC if using for other fluids than compressed air.

2. Extended periods of continuous energization

Please contact SMC if valves will be continuously energized for extended periods of time.

3. Operation of closed center solenoid valves

Even if this product is used for closed center solenoid valves or actuator with a load factor of more than 50%, jumping (stick-slip phenomenon) cannot be prevented.

4. Using a regulator in the outlet side

When mounting a regulator in the outlet side (A port side), use a residual pressure relief regulator (AR25K to 40K) or a check type regulator. With a standard regulator (AR10 to 60), the outlet side pressure may not be released when this valve is exhausted.

5. Operation of solenoid valves in the outlet side

To operate solenoid valves mounted on this product's outlet side (A port side), first confirm that the outlet side's pressure (P_A) has increased to become equal to the inlet side's pressure (P_P).

6. Operation

The residual pressure release function of this product is for emergency use only; therefore, avoid the operation in the same manner as ordinary 3 port valves.

7. Using a lubricator

If mounting a lubricator, mount it on the inlet side (P port side), of this product. If mounted on the outlet side (A port side), back flow of oil will occur and may spurt out of the valve's R port.

8. Operation for air blowing

This product cannot be operated for air blowing due to the mechanism that switches the main valve to be fully open after the outlet side's pressure increases to approximately 1/2 of the inlet side.

Selection

Caution

1. Voltage leakage

Particularly when using a C-R element (surge voltage suppressor) for protection of the switching element, use caution that leakage voltage will increase due to leakage current flowing through the C-R element, etc.

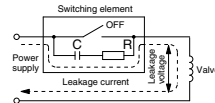

AC coil is 20% or less of rated voltage.

DC coil is 3% or less of rated voltage.

2. Low temperature operation

Although the valve can be operated at temperature as low as 0°C, measures should be taken to avoid solidifying or freezing drainage and moisture, etc.

Mounting

Warning

1. If air leakage increases or equipment does not operate properly, stop operation.

After mounting or maintenance, etc., connect the compressed air and power supplies, and perform appropriate function and leakage tests to confirm that the unit is mounted properly.

2. Operation manual

Mount and operate the product after reading the manual carefully and understanding its contents. Also keep the manual in a place where it can be referred to as necessary.

3. Painting and coating

Warnings or specifications printed or labeled on a product should not be erased, removed or covered up.

Furthermore, please contact SMC before painting the resin parts, as this may cause adverse effects depending on the solvent.

Adjustment

Caution

1. To perform the initial speed adjustment of a outlet side actuator, supply air from this valve's inlet side and turn ON the pilot valve. Then, rotate the needle counterclockwise from the fully closed position.



AV2000/3000/4000/5000 Series Specific Product Precautions 2

Be sure to read this before handling the products.

Refer to back page 50 for Safety Instructions and pages 387 to 391 for F.R.L. Precautions.

Piping

⚠ Caution

1. Preparation before piping

Before piping is connected, it should be thoroughly blown out by air (flushed) or washed to eliminate cutting chips, cutting oil, and other debris from the pipe inside.

2. Winding of sealant tape

When screwing piping or fittings into ports, ensure that chips from the pipe threads or sealing material do not enter the piping. Also, if sealant tape is used, leave 1.5 to 2 thread ridges exposed at the end of the threads.

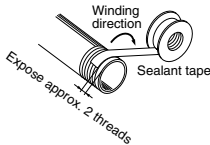

3. Tighten threads with the proper tightening torque.

When screwing fittings into valves, tighten with the torques given below.

Tightening Torque when Piping

| Connection threads | Proper tightening torque (N·m) |
|--------------------|--------------------------------|
| Rc 1/4 | 12 to 14 |
| Rc 3/8 | 22 to 24 |
| Rc 1/2 | 28 to 30 |
| Rc 3/4 | 28 to 30 |
| Rc 1 | 36 to 38 |

4. Piping to products

When piping to products, avoid making an error of supply port, etc., by referring to the operation manuals.

5. F.R.L. module combination

When connecting to a modular F.R.L. combinations (AC20 to 60), select one of the spacers, which are included. (Refer to page 657 for details.) However, modular combinations with AC40-06 are not possible.

Furthermore, connect soft start-up valves to the outlet side of the F.R.L. combination.

6. Inlet side piping conditions

The nominal size of the piping material's or equipment's bore should be equal to or larger than the soft start-up valve's port size. The composite effective area of the inlet side's (P port side's) piping or equipment should be equal to or larger than the values below.

| Model | Composite effective area (mm ²) |
|--------|---|
| AV2000 | 5 |
| AV3000 | 22 |
| AV4000 | 35 |
| AV5000 | 50 |

When the piping is restricted or the supply pressure is insufficient, the main valve will not switch and air leakage may occur from the R port.

Light/Surge Voltage Suppressor

⚠ Caution

| Voltage | AC and 100 VDC | 24 VDC or less |
|--------------------|----------------|----------------|
| Electrical circuit | | |

●Type G: Lead wire comes directly from the solenoid part. Connect it with the power source. Grommet with DC voltage surge suppressor has polarity. Connect red lead wire to + (positive) side and black to - (negative) side.

| Surge voltage suppressor | |
|--------------------------|----|
| DC | AC |
| | |

Electrical Connection

⚠ Caution

The DIN terminal is no polarity (+, -).

DIN terminal

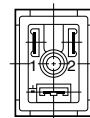

DIN (EN175301-803) Terminal

Y type DIN terminal corresponds to the DIN connector with terminal pitch 10 mm, which complies with EN175301-803B. Since the terminal pitch is different from the D type DIN connector, these two types are not interchangeable.

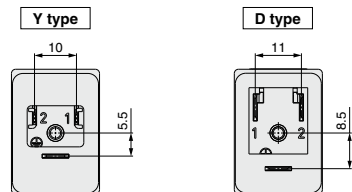



AV2000/3000/4000/5000 Series Specific Product Precautions 3

Be sure to read this before handling the products.

Refer to back page 50 for Safety Instructions and pages 387 to 391 for F.R.L. Precautions.

Air Supply

Warning

1. Use clean air.

Do not use compressed air which contains chemicals, synthetic oils containing organic solvents, salts or corrosive gases, etc., as this can cause damage or malfunction.

Caution

1. Install air filters.

Install air filters close to valves at their upstream side. A filtration degree of 5 μm or less should be selected.

2. Implement countermeasures by installing after-cooler or air dryer, or water separator, etc.

The air including excess drain may result in a malfunction of valves and other pneumatic equipment. Implement countermeasures by installing after-cooler or air dryer, or water separator, etc.

Operating Environment

Warning

1. Do not use valves in such environments where corrosive gases, chemicals, or brine or water or steam is airborne, or where valves can be directly exposed to any of those.

2. Do not use in an explosive environment.

3. Do not use in locations influenced by vibrations or impacts.

4. A protective cover, etc., should be used to shield valves from direct sunlight.

5. Shield valves from radiated heat generated by nearby heat sources.

6. Take suitable protective measures in locations where there are contacts with water droplets, oil, or welding spatter, etc.

7. In a dusty environment or when valve switching noise is intrusive, install a silencer in the R port to prevent dust from entering, and to reduce noise.

Lubrication

Caution

1. The valve has been lubricated for life at the factory, and does not require any further lubrication.

2. Use turbine oil Class 1, ISO VG32 (with no additives), if lubricated. Besides, if the lubrication is suspended halfway, the original lubricant will be lost and may result in a malfunction. Be sure to keep lubricating continuously.

Note) Refer to SMC's website for details about each manufacturer's brand name of class 1 turbine oil (no additive) ISO VG32. Additionally, please contact SMC for details about class 2 turbine oil (with additives) ISO VG32.

Maintenance

Warning

1. Perform maintenance and inspection as shown in the operation manual.

If handled improperly, damage may occur in machine or equipment or an operational error may result in.

2. Equipment removal and supply/exhaust of compressed air

When equipment is removed, first confirm that measures are implemented to prevent dropping of workpiece and runaway of equipment, etc. Then cut the supply pressure and power, and exhaust all compressed air from the system using its residual pressure release function.

3. Low frequency operation

Valves should be switched at least once every 30 days to prevent malfunction. (Use caution regarding the air supply.)

4. Manual override operation

When the manual override is operated, connected equipment will be actuated.

Confirm the safety before operating.

Caution

1. Drain removal

Remove drain from air filters periodically.

How to Find the Flow Rate

(At air temperature of 20°C)

Choke flow: $(P_2 + 0.1)/(P_1 + 0.1) \leq 0.5$

$$Q = 120 \times S \times (P_1 + 0.1) \times \sqrt{\frac{293}{273 + t}}$$

Subsonic flow: when $(P_2 + 0.1)/(P_1 + 0.1) > 0.5$

$$Q = 240 \times S \times \sqrt{(P_1 - P_2)(P_2 + 0.1)} \times \sqrt{\frac{293}{273 + t}}$$

Q: Air flow rate [L/min (ANR)]

S: Effective area (mm²)

P1: Inlet pressure [MPa]

P2: Outlet pressure [MPa]

t: Air temperature [°C]

Note 1) Formulas above are applied to pneumatics only.