

# 5 Port Pilot Operated Solenoid Valve

## VFS1000/2000/3000/4000/5000/6000 Series

### Metal Seal



### Series Variations

Series	Sonic conductance C [dm <sup>3</sup> /s-bar] 4/2 → 5/3(A/B) → R1/R2		Type of actuation	Voltage	Electrical entry	With light/surge voltage suppressor (Option)	Manual override				
	Single Double	3 position									
<b>Body Ported</b>	<b>VFS1000</b> (P.886)	1.8	1.8	2 position single 	(Standard) 100 VAC, 50/60 Hz 200 VAC, 50/60 Hz 24 VDC	Grommet (G) 	Grommet terminal (E) 	<input type="checkbox"/> With light/surge voltage suppressor <ul style="list-style-type: none"> <li>Grommet terminal (EZ)</li> <li>Conduit terminal (TZ)</li> <li>DIN terminal (DZ)</li> </ul> <input type="checkbox"/> With surge voltage suppressor <ul style="list-style-type: none"> <li>Grommet (GS)</li> </ul> Note: • Indicator light is not available for grommet type. Only surge voltage suppressor can be equipped on the middle of lead wire. • DC: There is polarity. (Lead wire Red: +, Black: -)	Non-locking push type (Flush)		
	<b>VFS2000</b> (P.894)	3.4	3.4	3 position closed center 	(Semi-standard) 110 to 120 VAC, 50/60 Hz 220 VAC, 50/60 Hz 240 VAC, 50/60 Hz 12 VDC 100 VDC	Conduit terminal (T) 	DIN terminal (D) 		Non-locking push type (Extended)		
	<b>VFS3000</b> (P.902)	6.8	6.5	3 position exhaust center 					Locking type (Tool required)		
* Locking type (lever) is not available for body ported VFS2000/3000 series.											
<b>Base Mounted</b>	<b>VFS2000</b> Plug-in type Non plug-in type (P.914)	2.8	2.7	2 position single 	(Standard) 100 VAC, 50/60 Hz 200 VAC, 50/60 Hz 24 VDC  (Semi-standard) 110 to 120 VAC, 50/60 Hz 220 VAC, 50/60 Hz 240 VAC, 50/60 Hz 12 VDC 100 VDC	Grommet (G) 	Grommet terminal (E) 	<input type="checkbox"/> With light/surge voltage suppressor <ul style="list-style-type: none"> <li>Plug-in type Conduit terminal (FZ)</li> <li>Non plug-in type Grommet terminal (EZ)</li> <li>Conduit terminal (TZ)</li> <li>DIN terminal (DZ)</li> </ul> <input type="checkbox"/> With surge voltage suppressor <ul style="list-style-type: none"> <li>Non plug-in type Grommet (GS)</li> </ul> Note: • Indicator light is not available for grommet type. Only surge voltage suppressor can be equipped on the middle of lead wire. • DC: There is polarity. (Lead wire Red: +, Black: -)	Non-locking push type (Flush)		
	<b>VFS3000</b> Plug-in type Non plug-in type (P.940)	5.8	5.4	2 position double 					Conduit terminal (F) 	Conduit terminal (FZ) 	Locking type (Tool required)
		<b>VFS4000</b> Plug-in type Non plug-in type (P.962)	12	11					3 position closed center 	Grommet terminal (E) 	DIN terminal (D) 
	<b>VFS5000</b> Plug-in type Non plug-in type (P.982)		20	17					3 position pressure center 		
	<b>VFS6000</b> Plug-in type Non plug-in type (P.998)	38	—	2 position double check 					Plug-in Conduit terminal (F) 	Non plug-in Grommet terminal (E) 	Non-locking push type (Flush)

## Manifold Variations

		Manifold						
		Bar base	Stacking base	With attachment plug lead wire	With terminal block	With multi-connector	With D-sub connector	Non plug-in (Connection to each valve)
<b>Body Ported</b>	VFS1000	● (P.891)						
	VFS2000	● (P.899)						
	VFS3000		● (P.908)					
<b>Base Mounted Plug-in Type</b>	VFS2000			● (P.922)	● (P.922)	● (P.922)	● (P.923)	
	VFS3000				● (P.946)	● (P.946)	● (P.946)	
	VFS4000				● (P.968)	● (P.968)	● (P.968)	
	VFS5000				● (P.988)	● (P.988)	● (P.988)	
<b>Base Mounted Non Plug-in Type</b>	VFS2000							● (P.923)
	VFS3000							● (P.946)
	VFS4000							● (P.968)
	VFS5000							● (P.988)

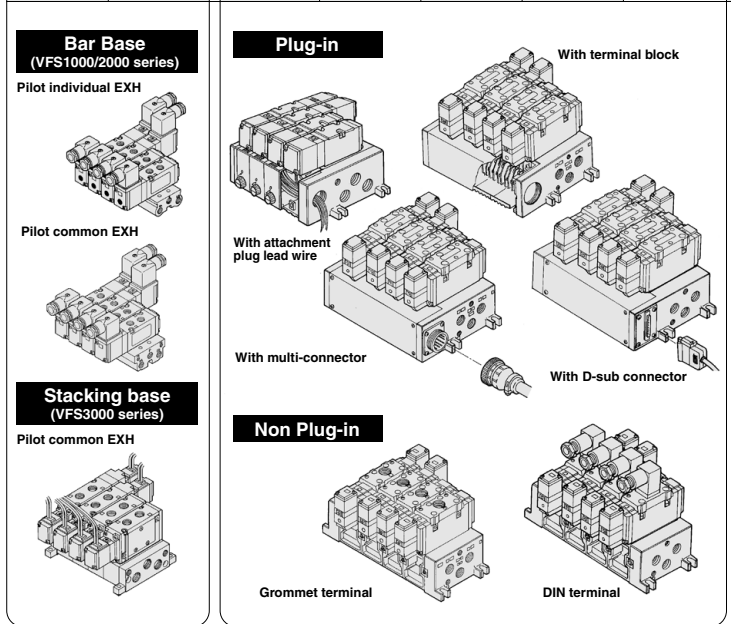

\* Bottom piping is available as an option.



# 5 Port Pilot Operated Solenoid Valve Metal Seal, Body Ported

# VFS1000 Series



● VFS1000 series is compatible with the old models, VF2□20 and VF2□30 series.

## Model

Type of actuation		Model		Port size	Flow rate characteristics						Max. operating cycle (cpm) <sup>(1)</sup>	Response time (ms) <sup>(2)</sup>	Weight (kg) <sup>(3)</sup>
					1 → 4/2 (P → A/B)			4/2 → 5/3 (A/B → R1/R2)					
					C [dm <sup>3</sup> /(s·bar)]	b	Cv	C [dm <sup>3</sup> /(s·bar)]	b	Cv			
2 position	Single	VFS1120	VFS1130	1/8	1.7	0.22	0.38	1.8	0.19	0.40	1200	15 or less	0.18
	Double	VFS1220	VFS1230	1/8	1.7	0.22	0.39	1.8	0.19	0.40	1200	13 or less	0.26
3 position	Closed center	VFS1320	VFS1330	1/8	1.6	0.20	0.37	1.8	0.20	0.41	600	20 or less	0.27
	Exhaust center	VFS1420	VFS1430	1/8	1.7	0.18	0.38	1.9	0.19	0.44	600	20 or less	0.27
	Pressure center	VFS1520	VFS1530	1/8	1.7	0.24	0.40	1.6	0.18	0.37	600	20 or less	0.27

Note 1) Based on JIS B 8419: 2010 (once per 30 days) for the minimum operating frequency.

Note 2) Based on JIS B 8419: 2010. (The value at supply pressure 0.5 MPa, ambient/fluid temperature (= 20°C))

However, this excludes when in an adhered state. (Be aware that after long periods of holding time, there may be delays in the initial response time.)

Note 3) In the case of grommet type

Note 4) "Note 1)" and "Note 2)" are with controlled clean air.

**Compact yet provides a large flow capacity**  
C: 1.8 dm<sup>3</sup>/(s·bar)

**Low power consumption:**  
1.8 W DC



## Symbol

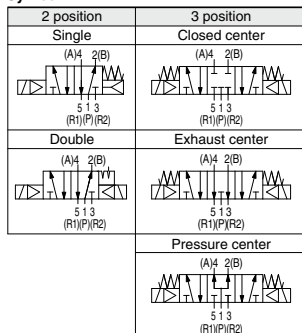

## Standard Specifications

Valve specifications		Fluid	Air	
Valve specifications	Maximum operating pressure	1.0 MPa		
	Min. operating pressure	2 position	0.1 MPa	
		3 position	0.15 MPa	
	Proof pressure	1.5 MPa		
	Ambient and fluid temperature	-10 to 60°C <sup>(1)</sup>		
	Lubrication	Non-lube <sup>(2)</sup>		
	Pilot valve manual override	Non-locking push type (Flush)		
	Impact/Vibration resistance	150/50 m/s <sup>2</sup> <sup>(3)</sup>		
	Enclosure	Dustproof (Equivalent to IP50) <sup>(4)</sup>		
	Electricity specifications	Coil rated voltage	100, 200 VAC, 50/60 Hz; 24 VDC	
Allowable voltage fluctuation		-15 to +10% of rated voltage		
Coil insulation type		Class B or equivalent (130°C) <sup>(5)</sup>		
Apparent power (Power consumption) AC		Inrush	5.6 VA (50 Hz), 5.0 VA (60 Hz)	
		Holding	3.4 VA (2.1 W)/50 Hz, 2.3 VA (1.5 W)/60 Hz	
Power consumption (DC)		1.8 W (2.04 W: With light/surge voltage suppressor)		
Electrical entry		Grommet, Grommet terminal, Conduit terminal, DIN terminal		

Note 1) Use dry air at low temperatures.

Note 2) Use turbine oil Class 1 (ISO VG32), if lubricated.

Note 3) Impact resistance: No malfunction occurred when it is tested with a drop tester in the axial direction and at the right angles to the main valve and armature in both energized and de-energized states every once for each condition. (Values at the initial period)

Vibration resistance: No malfunction occurred in a one-sweep test between 45 and 2000 Hz. Test was performed at both energized and de-energized states in the axial direction and at the right angles to the main valve and armature. (Values at the initial period)

Note 4) Based on JIS C 0920.

Note 5) Based on JIS C 4003.

## Option Specifications

Pilot valve manual override	Non-locking push type (Extended), Locking type (Tool required), Locking type (Lever)
Coil rated voltage	110 to 120, 220, 240 VAC (50/60 Hz)
Option	12, 100 VDC
Option	With light/surge voltage suppressor <sup>(Note)</sup>
Foot bracket (With screw)	Part No.: AXT626-10A, VFS1120 (single) only

Note) Grommet type is available only w/ surge voltage suppressor (which is directly connected with lead wire).

## Manifold

Body type	Applicable manifold base (Pilot EXH)
VFS1□20	Bar manifold (Individual EXH)
VFS1□30	Bar manifold (Common EXH base side)

Note) VFS1□30: Manifold only. Cannot be used as a single unit.

# 5 Port Pilot Operated Solenoid Valve Metal Seal, Body Ported **VFS1000 Series**

## How to Order

**VFS1** 1 20 - 1 G     - 01      

**Symbol**

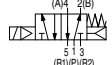
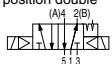
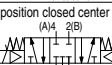
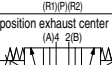
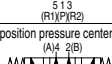
1	2 position single (A/4 2/B) 
2	2 position double (A/4 2/B) 
3	3 position closed center (A/4 2/B) 
4	3 position exhaust center (A/4 2/B) 
5	3 position pressure center (A/4 2/B) 

**Body (Pilot exhaust)**

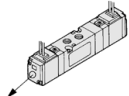
**20:** Individual EXH  

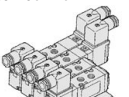
**30\*:** Common EXH  

\* Manifold only

**Option**

**CE/UKCA-compliant**

Nil	—
Q	CE/UKCA-compliant

**Thread type**





Nil	Rc
N*	NPT
T*	NPTF
F*	G

\* Semi-standard

**Port size**

01	1/8"
----	------

**Manual override**

<b>Nil:</b> Non-locking push type (Flush) 	<b>A*:</b> Non-locking push type (Extended) 	<b>B*:</b> Locking type 	<b>C*:</b> Locking type (Lever) 
--	--	--	---

\* Semi-standard

**Light/Surge voltage suppressor**

Nil	None
Z	With light/surge voltage suppressor
S*	With surge voltage suppressor

\* Grommet type is available only w/ surge voltage suppressor, not w/ indicator light.

**Electrical entry**

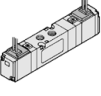
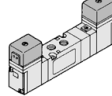
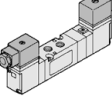
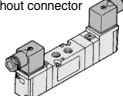
<b>G:</b> Grommet 	<b>E:</b> Grommet terminal 	<b>T:</b> Conduit terminal 	<b>D, Y:</b> DIN terminal <b>DO, YO:</b> DIN terminal without connector 
--	---	---	---

**Coil rated voltage**

1	100 VAC (50/60 Hz)
2	200 VAC (50/60 Hz)
3*	110 to 120 VAC (50/60 Hz)
4*	220 VAC (50/60 Hz)
5	24 VDC
6*	12 VDC
7*	240 VAC (50/60 Hz)

\* Semi-standard  
For other rated voltages, please consult with SMC.

Note) No mounting bolts and gaskets are supplied with the valve single unit.

SV
SYJ
SZ
VF
VP4
VQ 1/2
VQ 4/5
VQC 1/2
VQC 4/5
VQZ
SQ
VFS
VFR
VQ7

## How to Order Pilot Valve Assembly

**SF4** - 1 DZ   - 21

**Coil rated voltage**

1	100 VAC, 50/60 Hz
2	200 VAC, 50/60 Hz
3*	110 to 120 VAC (50/60 Hz)
4*	220 VAC, 50/60 Hz
5	24 VDC
6*	12 VDC
7*	240 VAC, 50/60 Hz

\* Semi-standard  
For other rated voltages, please consult with SMC.

**Electrical entry, Light/Surge voltage suppressor**

G	Grommet
GS	Grommet with surge voltage suppressor
D	DIN terminal
DZ	DIN terminal with light/surge voltage suppressor
DO	DIN terminal **
DOZ	DIN terminal with light/surge voltage suppressor **
Y*	DIN terminal
YZ*	DIN terminal with light/surge voltage suppressor
YO*	DIN terminal **
YOZ*	DIN terminal with light/surge voltage suppressor **
T	Conduit terminal
TZ	Conduit terminal with light/surge voltage suppressor
E	Grommet terminal
EZ	Grommet terminal with light/surge voltage suppressor

\* Y: Conforming to DIN43650B standard  
\*\* DIN connector is not attached.

**Manual override**

<b>Nil</b> Non-locking push type (Flush)	<b>A*</b> Non-locking push type (Extended)
<b>B*</b> Locking type (Tool required)	<b>C*</b> Locking type (Lever)

\* Semi-standard

**Applicable model**

21	For VFS1□20	Individual pilot exhaust
22	For VFS1□30	Common pilot exhaust

# VFS1000 Series

## Cylinder Speed Chart

Use as a guide for selection.  
Please confirm the actual conditions with SMC Sizing Program.

### Body Ported

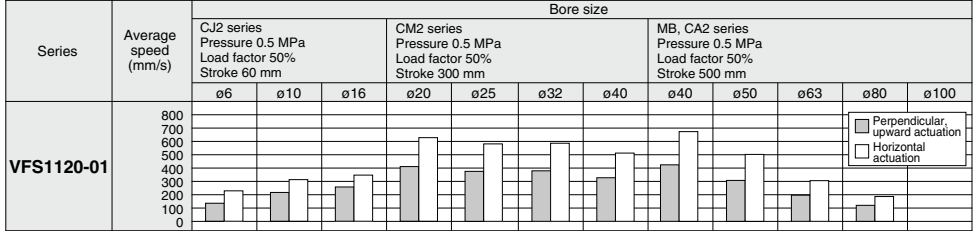

### Conditions

	Body ported	CJ2 series	CM2 series	MB, CA2 series
VFS1120-01	Tube bore x Length	T0604 x 1 m	T0806 x 1 m	
	Speed controller	AS3002F-06	AS3002F-08	
	Silencer	AN101-01		

- \* It is when the cylinder is extending that is meter-out controlled by speed controller which is directly connected with cylinder, and its needle valve with being fully open.
- \* The average velocity of the cylinder is the value that the stroke is divided by the total stroke time.
- \* Load factor: ((Load mass x 9.8)/Theoretical force) x 100%

### Construction

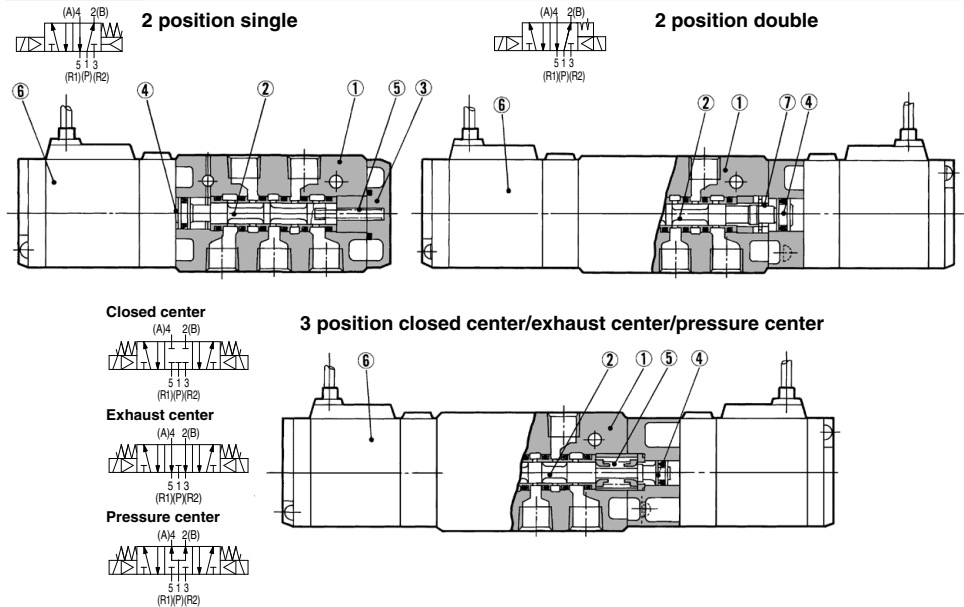

### Component Parts

No.	Description	Material	Note
1	Body	Aluminum die-casted	—
2	Spool/Sleeve	Stainless steel	—
3	End plate	Resin	—
4	Piston	Resin	—
5	Return spring	Stainless steel	—
6	Pilot valve assembly	—	—
7	Detent assembly	—	—

\* Refer to "How to Order Pilot Valve Assembly" on page 887.

**2 Position Single — Grommet, Grommet terminal, Conduit terminal, DIN terminal**

**Grommet : VFS1120-□G**

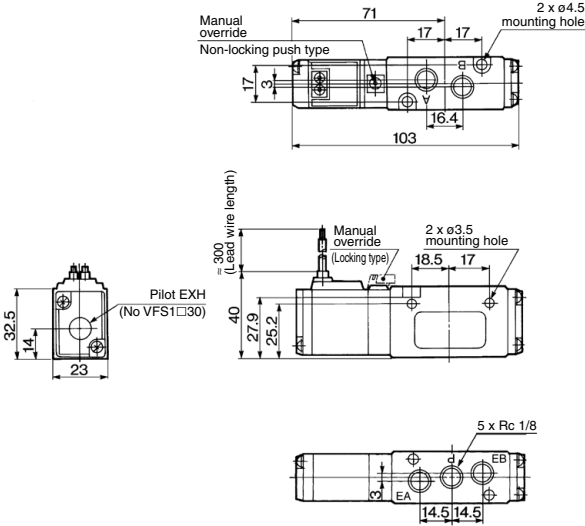

**Foot bracket (F)  
Part no. : AXT626-10A**

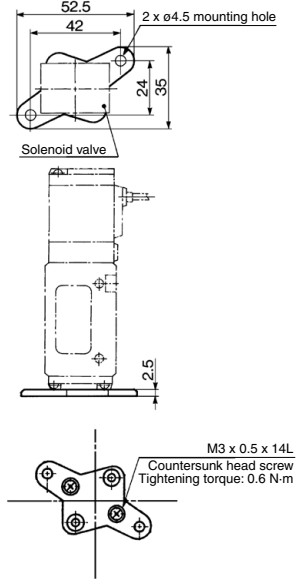

- SV
- SYJ
- SZ
- VF
- VP4
- VQ 1/2
- VQ 4/5
- VQC 1/2
- VQC 4/5
- VQZ
- SQ
- VFS
- VFR
- VQ7

**Grommet terminal: VFS1120-□E/EZ**

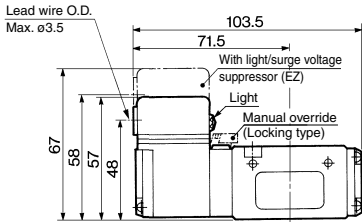

**DIN terminal: VFS1120-□D/DZ/Y/YZ**

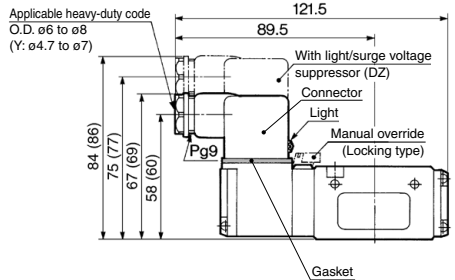

**Conduit terminal: VFS1120-□T/TZ**

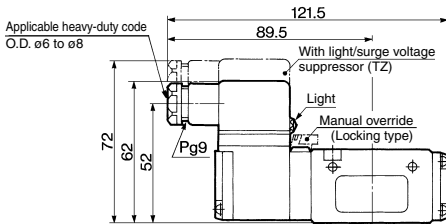

**DIN Connector/Gasket Part No.**

Description	D(Z) type	Y(Z) type
Connector	B1B09-2A6	GMN209
Gasket	CAXT623-6-7-12	CAXT623-6-7-13

# VFS1000 Series

## 2 Position Double, 3 Position — Grommet, Grommet terminal, Conduit terminal, DIN terminal

Grommet: VFS1220-□G, VFS1320-□G, VFS1420-□G, VFS1520-□G

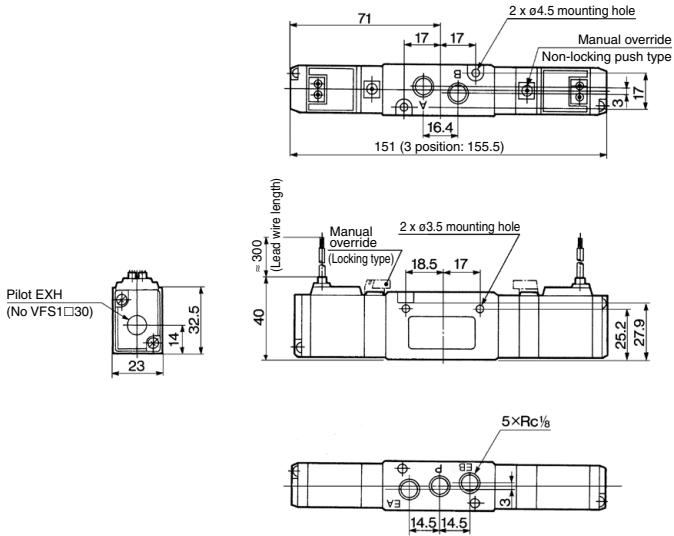

Grommet terminal: VFS1220-□E/EZ VFS1320-□E/EZ  
VFS1420-□E/EZ VFS1520-□E/EZ

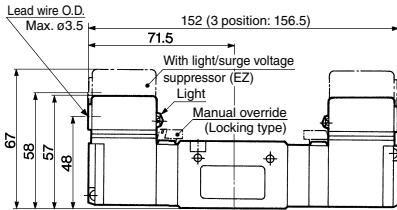

Conduit terminal: VFS1220-□T/TZ VFS1320-□T/TZ  
VFS1420-□T/TZ VFS1520-□T/TZ

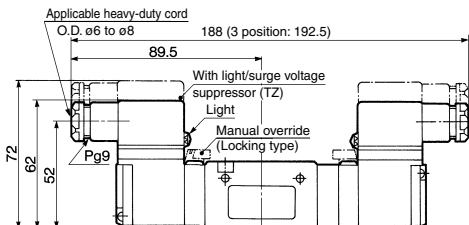

DIN terminal : VFS1220-□D/DZ/Y/YZ  
VFS1320-□D/DZ/Y/YZ  
VFS1420-□D/DZ/Y/YZ  
VFS1520-□D/DZ/Y/YZ

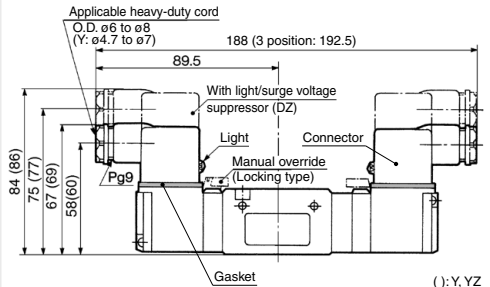

DIN Connector/Gasket Part No.

Description	D(Z) type	Y(Z) type
Connector	B1B09-2A6	GMN209
Gasket	CAXT623-6-7-12	CAXT623-6-7-13



# VFS1000 Series Manifold Specifications Single Base Type

## Compact and lightweight

Compact due to manifolding on a single base for mounting in small spaces.

## Keeps environmental air clean from pilot exhaust

Use of the VV5FS1-30 manifold can exhaust intensively the pilot exhaust gas to the base side, and can prevent environmental aggravation due to noise and oil mist.

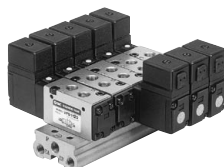

VV5FS1-20

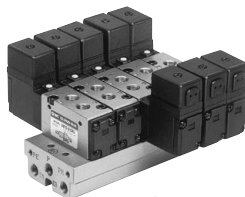

VV5FS1-30

Part no. for mounting bolt and gasket

BG-VFS1030

## Specifications

Manifold base type	Bar manifold, Body ported
Stations	Max. 15 stations

## Port Specifications

Symbol	Passage		Porting specifications: Rc (Connecting port size)		
	1(P)	5(R1), 3(R2)	Base	Valve	Base
1	Common	Common	1(P) Side/(1/8)	4(A), 2(B) Top/(1/8)	5(R1), 3(R2) Side/(1/8)

## Option

Blanking plate	VVFS1000-10A-1	With gasket, screw
----------------	----------------	--------------------



## How to Order Manifold Base

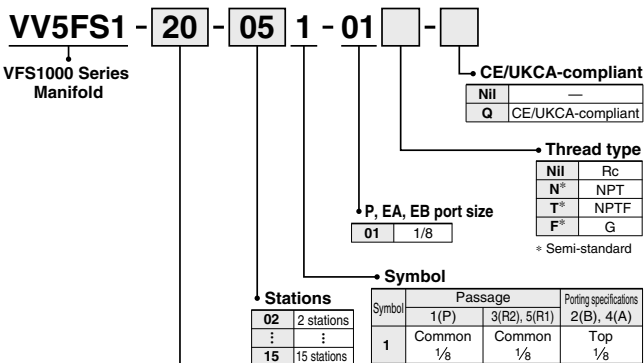

SV

SYJ

SZ

VF

VP4

VQ

1/2

VQ

4/5

VQC

1/2

VQC

4/5

VQZ

SQ

VFS

VFR

VQ7

## How to Order Manifold Assembly [Example]

Add the valve and option part numbers in order starting from the first station on the D side.

<Example>

(Manifold base)  
(2 position single)  
(2 position double)  
(Blanking plate)

VV5FS1-20-061-01 ..... 1  
\* VFS1120-1D-01 ..... 3  
\* VFS1220-1D-01 ..... 2  
\* VVFS1000-10A-1 ..... 1

The asterisk denotes the symbol for assembly. Prefix it to the part numbers of the solenoid valve.

# VFS1000 Series

## Type 20 Manifold — Pilot individual exhaust: VVFS1-20-Station 1-01

Grommet: G

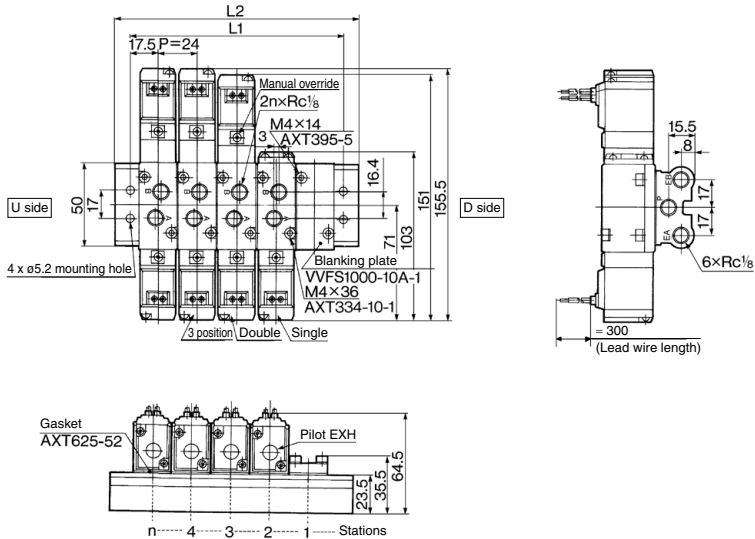

Formula for manifold weight  $M = 0.049n + 0.059$  (kg) n: Station

### Grommet terminal: E/EZ

### Conduit terminal: T/TZ

### DIN terminal: D/DZ/Y/YZ

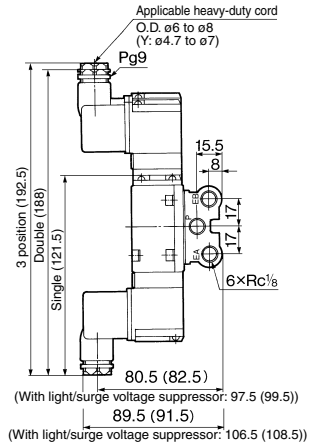
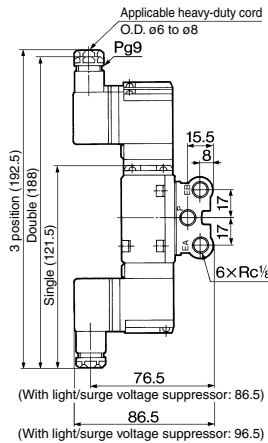
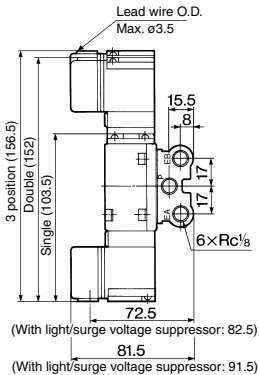

( ): Y, YZ

n: Station

Symbol	Stations	2	3	4	5	6	7	8	9	10	Formula
L1		59	83	107	131	155	179	203	227	251	$L1 = 24 \times n + 11$
L2		77	101	125	149	173	197	221	245	269	$L2 = 24 \times n + 29$

# 5 Port Pilot Operated Solenoid Valve Metal Seal, Body Ported **VFS1000 Series**

## Type 30 Manifold — Pilot common exhaust: VV5FS1-30-Station 1-01

Grommet: G

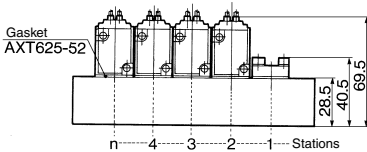
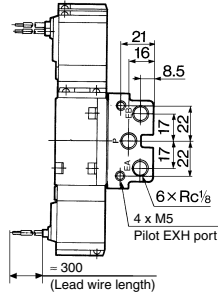
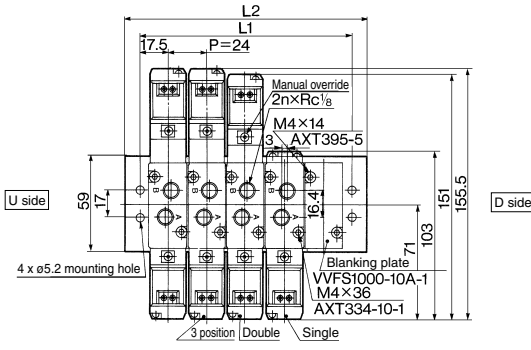

Formula for manifold weight  $M = 0.079n + 0.093$  (kg) n: Station

### Grommet terminal: E/EZ

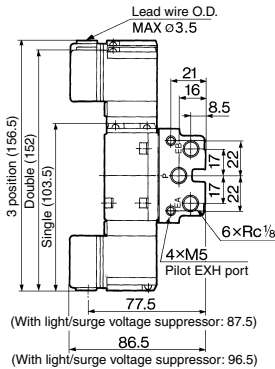

### Conduit terminal: T/TZ

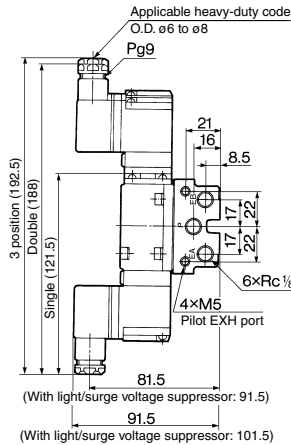

### DIN terminal: D/DZ/Y/YZ

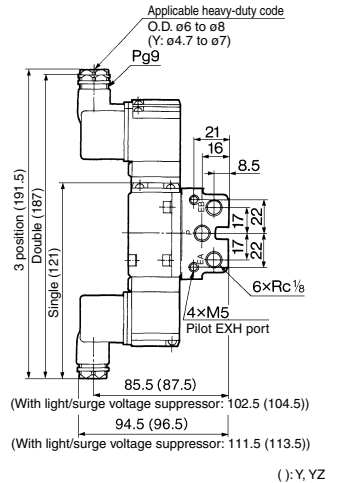

Symbol	Stations	2	3	4	5	6	7	8	9	10	Formula
L1		59	83	107	131	155	179	203	227	251	$L1 = 24 \times n + 11$
L2		77	101	125	149	173	197	221	245	269	$L2 = 24 \times n + 29$

n: Station

(:): Y, YZ

- SV
- SYJ
- SZ
- VF
- VP4
- VQ 1/2
- VQ 4/5
- VQC 1/2
- VQC 4/5
- VQZ
- SQ
- VFS
- VFR
- VQ7

# 5 Port Pilot Operated Solenoid Valve Metal Seal, Body Ported

## VFS2000 Series



### Model

Type of actuation	Model		Port size Rc	Flow rate characteristics						Max. operating cycle (cpm) <sup>(1)</sup>	Response time (ms) <sup>(2)</sup>	Weight (kg) <sup>(3)</sup>	
				1 → 4/2 (P → A/B)			4/2 → 5/3 (A/B → R1/R2)						
				C [dm <sup>3</sup> /(s·bar)]	b	Cv	C [dm <sup>3</sup> /(s·bar)]	b	Cv				
2 position	Single	VFS2120	VFS2130	1/8	3.2	0.24	0.78	3.4	0.28	0.82	1200	22 or less	0.26
				1/4	4.0	0.20	0.90	3.5	0.32	0.85			
	Double	VFS2220	VFS2230	1/8	3.2	0.24	0.78	3.4	0.28	0.82	1200	13 or less	0.35
				1/4	4.0	0.20	0.90	3.5	0.32	0.85			
3 position	Closed center	VFS2320	VFS2330	1/8	3.2	0.24	0.78	3.2	0.27	0.80	600	40 or less	0.42
				1/4	4.0	0.20	0.90	3.4	0.29	0.83			
	Exhaust center	VFS2420	VFS2430	1/8	3.2	0.25	0.79	3.4	0.26	0.82	600	40 or less	0.42
				1/4	4.0	0.20	0.90	3.4	0.32	0.84			
	Pressure center	VFS2520	VFS2530	1/8	3.1	0.23	0.75	3.3	0.27	0.80	600	40 or less	0.42
				1/4	4.0	0.24	0.92	3.3	0.30	0.82			

Note 1) Based on JIS B 8419: 2010 (once per 30 days) for the minimum operating frequency.

Note 2) Based on JIS B 8419-2010. (The value at supply pressure 0.5 MPa, ambient/fluid temperature (= 20°C))

However, this excludes when in an adhered state. (Be aware that after long periods of holding time, there may be delays in the initial response time.)

Note 3) In the case of grommet type Note 4) Factors of "Note 1)" and "Note 2)" are achieved in controlled clean air.

Compact yet provides a high flow capacity  
1/4: C: 3.4 dm<sup>3</sup>/(s·bar)

Low power consumption:  
1.8 W DC



### Symbol

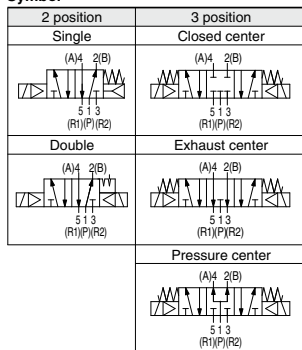

### Standard Specifications

Valve specifications	Fluid	Air
Maximum operating pressure		1.0 MPa
Minimum operating pressure		0.1 MPa
Proof pressure		1.5 MPa
Ambient and fluid temperature		-10 to 60°C <sup>(1)</sup>
Lubrication		Non-lube <sup>(2)</sup>
Pilot valve manual override		Non-locking push type (Flush)
Impact/Vibration resistance		150/50 m/s <sup>2</sup> <sup>(3)</sup>
Enclosure		Dustproof (Equivalent to IP50) <sup>(4)</sup>
Coil rated voltage		100, 200 VAC, 50/60 Hz; 24 VDC
Allowable voltage fluctuation		-15 to +10% of rated voltage
Coil insulation type		Class B or equivalent (130°C) <sup>(5)</sup>
Apparent power (Power consumption) AC	Inrush Holding	5.6 VA (50 Hz), 5.0 VA (60 Hz)
		3.4 VA (2.1 W)/50 Hz, 2.3 VA (1.5 W)/60 Hz
Power consumption		1.8 W (2.04 W: With light/surge voltage suppressor)
Electrical entry		Grommet terminal, Conduit terminal, DIN terminal

Note 1) Use dry air at low temperatures.

Note 2) Use turbine oil Class 1 (ISO VG32), if lubricated.

Note 3) Impact resistance: No malfunction occurred when it is tested with a drop tester in the axial direction and at the right angles to the main valve and armature in both energized and de-energized states every once for each condition. (Values at the initial period)

Vibration resistance: No malfunction occurred in a one-sweep test between 45 and 2000 Hz. Test was performed at both energized and de-energized states in the axial direction and at the right angles to the main valve and armature. (Values at the initial period)

Note 4) Based on JIS C 0920.

Note 5) Based on JIS C 4003.

### Option Specifications

Pilot type	External pilot <sup>(1)</sup>
Pilot valve manual override	Non-locking push type (Extended), Locking type (Tool required)
Coil rated voltage	110 to 120, 220, 240 VAC (50/60 Hz) 12, 100 VDC
Option	With light/surge voltage suppressor <sup>(2)</sup>
Foot bracket (With screw)	Part no.: VFN200-17A, VFS2120 (single) only

Note 1) Operating pressure: 0 to 1.0 MPa. Pilot pressure: 0.1 to 1.0 MPa.

Note 2) Grommet type is available only w/ surge voltage suppressor (which is directly connected with lead wire), not w/ indicator light.

### Manifold

Body type	Applicable manifold base (Pilot EXH)
VFS2□20	Bar manifold (Individual EXH)
VFS2□30	Bar manifold (Common EXH base side)

Note) VFS2□30: Manifold only. Cannot be used as a single unit.

# 5 Port Pilot Operated Solenoid Valve Metal Seal, Body Ported **VFS2000 Series**



## How to Order

VFS2 **1** **20** - **1** **G** - **01** - - -

**Symbol**

1: 2 position single  
(A4, 2B)

2: 2 position double  
(A4, 2B)

3: 3 position closed center  
(A4, 2B)

4: 3 position exhaust center  
(A4, 2B)

5: 3 position pressure center  
(A4, 2B)

\* Reverse pressure: Can be used by external pilot specifications.

### Body (Pilot exhaust)

20: Individual EXH

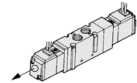

30: Common EXH\*

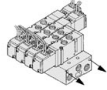

\* Manifold only

### Pilot type

Nil	Internal pilot
R*	External pilot

\* Semi-standard: Individual external pilot (External pilot port: Body side)

### Option

F: With foot bracket

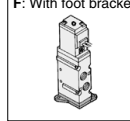

\* Mountable only for VFS2120.

Nil	—
Q	CE/UKCA-compliant

### Port size

01	1/8
02	1/4

\* Semi-standard

### Thread type

Nil	Rc
N*	NPT
T*	NPTF
F*	G

\* Semi-standard

### Manual override

Nil: Non-locking push type (Flush)	A*: Non-locking push type (Extended)	B*: Locking type (Tool required)
------------------------------------	--------------------------------------	----------------------------------

\* Semi-standard

### Light/Surge voltage suppressor

Nil	None
Z	With light/surge voltage suppressor
S*	With surge voltage suppressor

\* Grommet type is available only w/ surge voltage suppressor, not w/ indicator light.

### Electrical entry

G: Grommet

E: Grommet terminal

T: Conduit terminal

D, Y: DIN terminal  
DO, YO: DIN terminal without connector

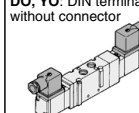
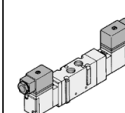
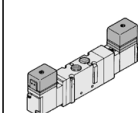
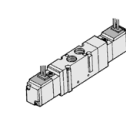

### Coil rated voltage

1	100 VAC (50/60 Hz)
2	200 VAC (50/60 Hz)
3*	110 to 120 VAC (50/60 Hz)
4*	220 VAC (50/60 Hz)
5	24 VDC
6*	12 VDC
7*	240 VAC (50/60 Hz)

\* Semi-standard  
For other rated voltages, please consult with SMC.

Note) No mounting bolts and gaskets are supplied with the valve single unit.

## How to Order Pilot Valve Assembly

SF4 - **1** **DZ** - **12**

### Coil rated voltage

1	100 VAC, 50/60 Hz
2	200 VAC, 50/60 Hz
3*	110 to 120 VAC (50/60 Hz)
4*	220 VAC, 50/60 Hz
5	24 VDC
6*	12 VDC
7*	240 VAC, 50/60 Hz

\* Semi-standard  
For other rated voltages, please consult with SMC.

### Electrical entry, Light/Surge voltage suppressor

G	Grommet
GS	Grommet with surge voltage suppressor
D	DIN terminal
DZ*	DIN terminal with light/surge voltage suppressor
DO*	DIN terminal**
DOZ*	DIN terminal with light/surge voltage suppressor**
Y*	DIN terminal
YZ*	DIN terminal with light/surge voltage suppressor
YO*	DIN terminal**
YOZ*	DIN terminal with light/surge voltage suppressor**
T	Conduit terminal
TZ	Conduit terminal with light/surge voltage suppressor
E	Grommet terminal
EZ	Grommet terminal with light/surge voltage suppressor

\* Y: Conforming to DIN43650B standard  
\*\* DIN connector is not attached.

### Applicable model

12	For VFS2□20	Individual pilot exhaust
13	For VFS2□30	Common pilot exhaust

### Manual override

Nil	Non-locking push type (Flush)
A*	Non-locking push type (Extended)
B*	Locking type (Tool required)

\* Semi-standard

# VFS2000 Series

## Cylinder Speed Chart

Use as a guide for selection.  
Please confirm the actual conditions with SMC Sizing Program.

### Body Ported

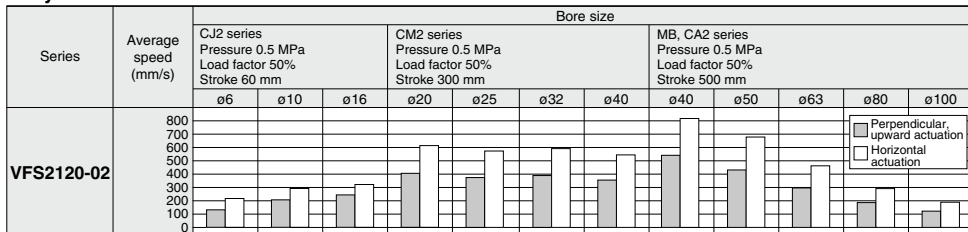

### Conditions

	Body ported	CJ2 series	CM2 series	MB, CA2 series
VFS2120-02	Tube bore x Length	T0604 x 1 m	T1075 x 1 m	
	Speed controller	AS3001F-06	AS4001F-10	
	Silencer		AN110-01	

- \* It is when the cylinder is extending that is meter-out controlled by speed controller which is directly connected with cylinder, and its needle valve with being fully open.
- \* The average velocity of the cylinder is the value that the stroke is divided by the total stroke time.
- \* Load factor: ((Load mass x 9.8)/Theoretical force) x 100%

## Construction

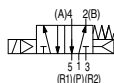

2 position single

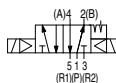

2 position double

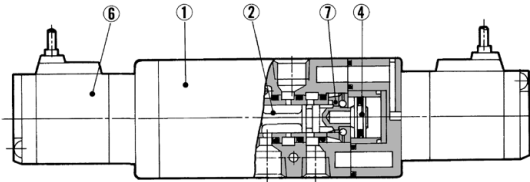
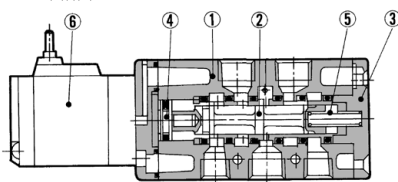

### Closed center

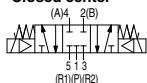

### 3 position closed center/exhaust center/pressure center

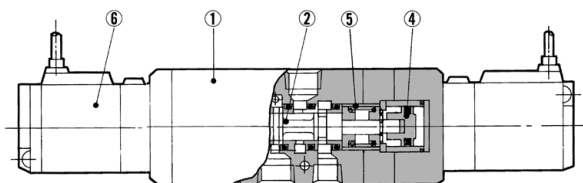
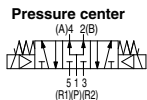
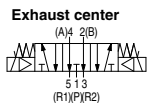

## Component Parts

No.	Description	Material	Note
1	Body	Aluminum die-casted	—
2	Spool/Sleeve	Stainless steel	—
3	End plate	Resin	—
4	Piston	Resin	—
5	Return spring	Stainless steel	—
6	Pilot valve assembly	—	—
7	Detent assembly	—	—

\* Refer to "How to Order Pilot Valve Assembly" on page 895.

**2 Position Single — Grommet, Grommet terminal, Conduit terminal, DIN terminal**

**Grommet: VFS2120-□G**

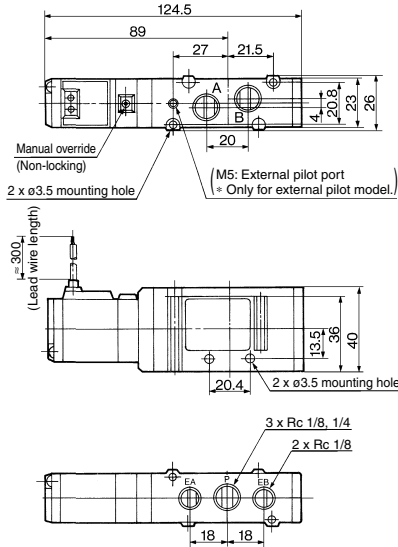

**Foot bracket (F)  
Part no.: VFN200-17A**

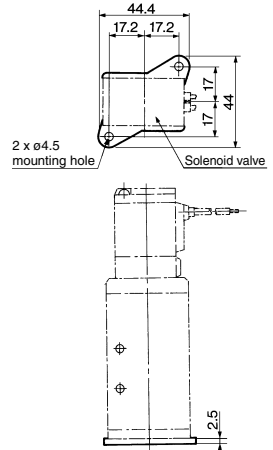

**Grommet terminal: VFS2120-□E/EZ**

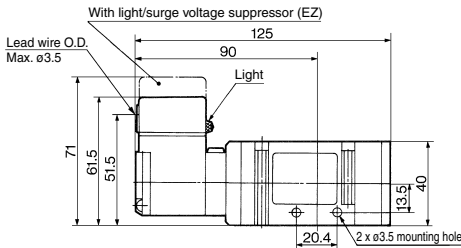

**DIN terminal: VFS2120-□D/DZ/Y/YZ**

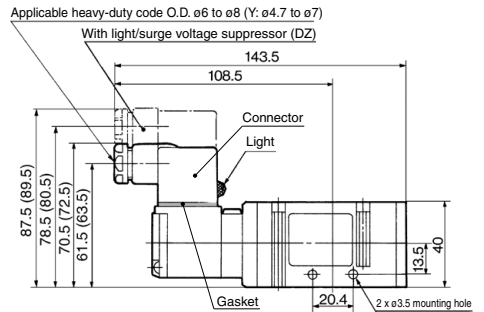

**Conduit terminal: VFS2120-□T/TZ**

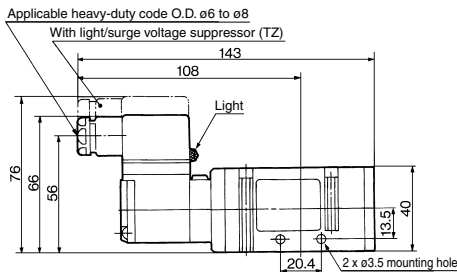

( ): Y, YZ

**DIN Connector/Gasket Part No.**

Description	D(Z) type	Y(Z) type
Connector	B1B09-2A6	GMN209
Gasket	CAXT623-6-7-12	CAXT623-6-7-13

# VFS2000 Series

## 2 Position Double, 3 Position — Grommet, Grommet terminal, Conduit terminal, DIN terminal

Grommet: VFS2220-□G, VFS2320-□G, VFS2420-□G, VFS2520-□G

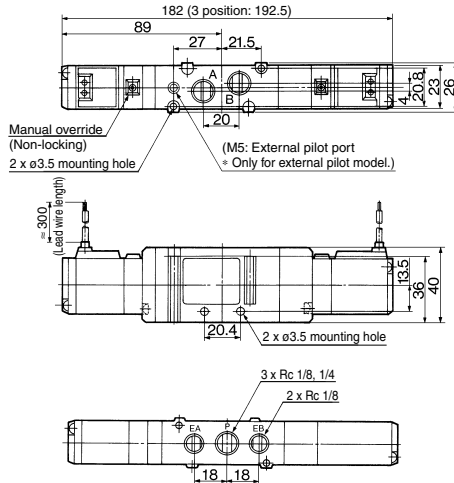

Grommet terminal: VFS2220-□E/EZ VFS2320-□E/EZ  
VFS2420-□E/EZ VFS2520-□E/EZ

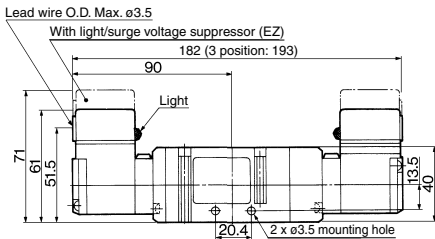

Conduit terminal: VFS2220-□T/TZ VFS2320-□T/TZ  
VFS2420-□T/TZ VFS2520-□T/TZ

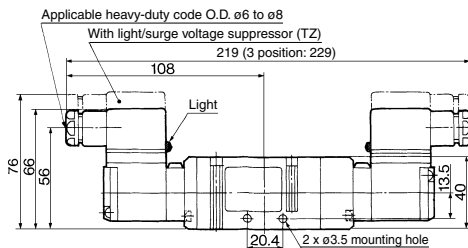

DIN terminal: VFS2220-□D/DZ/Y/YZ  
VFS2320-□D/DZ/Y/YZ  
VFS2420-□D/DZ/Y/YZ  
VFS2520-□D/DZ/Y/YZ

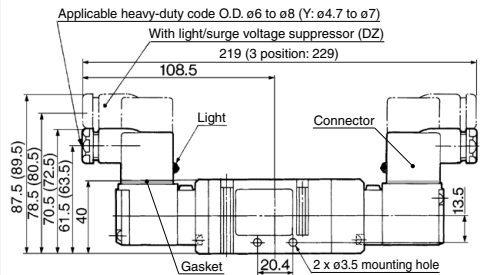

(): Y, YZ

DIN Connector/Gasket Part No.

Description	D(Z) type	Y(Z) type
Connector	B1B09-2A6	GMN209
Gasket	CAXT623-6-7-12	CAXT623-6-7-13



# VFS2000 Series Manifold Specifications Single Base Type

## Keeps environmental air clean from pilot exhaust

Use of the VV5FS2-30 manifold can exhaust intensively the pilot exhaust gas to the base side, and can prevent environmental aggravation due to noise and oil mist.



VV5FS2-20

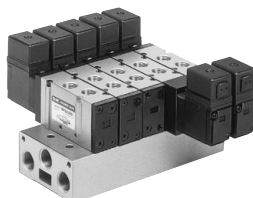

VV5FS2-30

Part no. for mounting bolt and gasket  
BG-VFS2030

## Specifications

Manifold base type	Bar manifold, Body ported
Stations	Max. 15 stations

## Port Specifications

Symbol	Passage		Porting specifications		
	1(P)	5(R1), 3(R2)	Base 1(P)	Valve 2(B), 4(A)	Base 3(R2), 5(R1)
1	Common	Common	Side: 3/8	Top: 1/8, 1/4	Side: 3/8

## Option

Blanking plate	VVFS2000-10A-1	With gasket, screw
----------------	----------------	--------------------



## How to Order Manifold Base

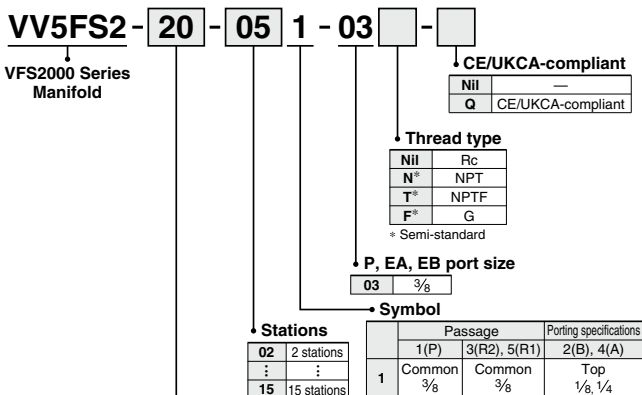

## Base model

Model	Pilot exhaust	Applicable valve model
20	Pilot individual EXH 	VFS2□20-□□ <sup>01</sup> <sub>02</sub>
30	Pilot common EXH 	VFS2□30-□□ <sup>01</sup> <sub>02</sub> *VFS2□20-□□ <sup>01</sup> <sub>02</sub> mountable

## How to Order Manifold Assembly [Example]

Add the valve and option part numbers in order starting from the first station on the D side.

### <Example>

(Manifold base) VV5FS2-20-061-03 ..... 1  
 (2 position single) \* VFS2120-1D-02 ..... 3  
 (2 position double) \* VFS2220-1D-02 ..... 2  
 (Blanking plate) \* VVFS2000-10A-1 ..... 1

The asterisk denotes the symbol for assembly. Prefix it to the part numbers of the solenoid valve.

# VFS2000 Series

## Type 20 Manifold — Pilot individual exhaust: VV5FS2-20-Station 1-03

### Grommet: G

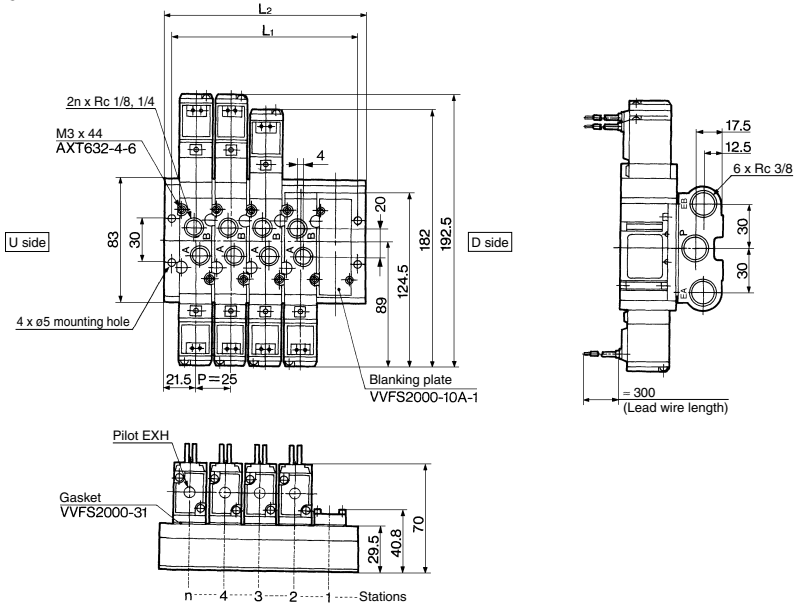

Formula for manifold weight  $M = 0.108n + 0.068$  (kg) n: Station

### Grommet terminal: E/EZ

### Conduit terminal: T/TZ

### DIN terminal: D/DZ/Y/YZ

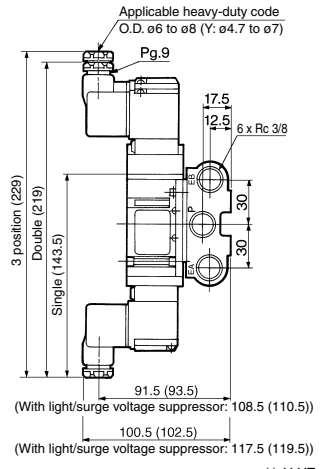
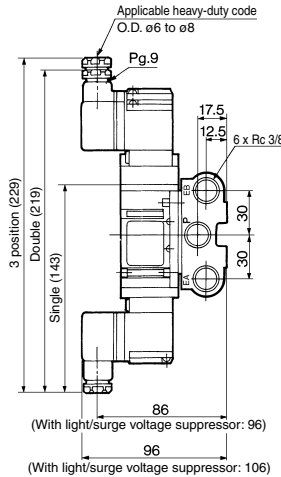
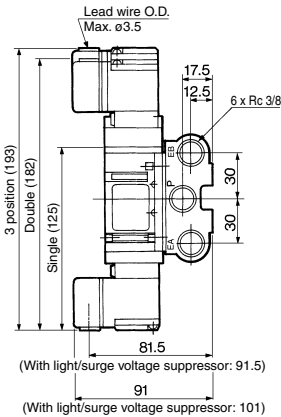

( ): Y, YZ

n: Station

Stations	2	3	4	5	6	7	8	9	10	Formula
$L_1$	58	83	108	133	158	183	208	233	258	$L_1 = 25 \times n + 8$
$L_2$	68	93	118	143	168	193	218	243	268	$L_2 = 25 \times n + 18$

# 5 Port Pilot Operated Solenoid Valve Metal Seal, Body Ported **VFS2000 Series**

## Type 30 Manifold — Pilot common exhaust: VV5FS2-30-Station 1-03

### Grommet: G

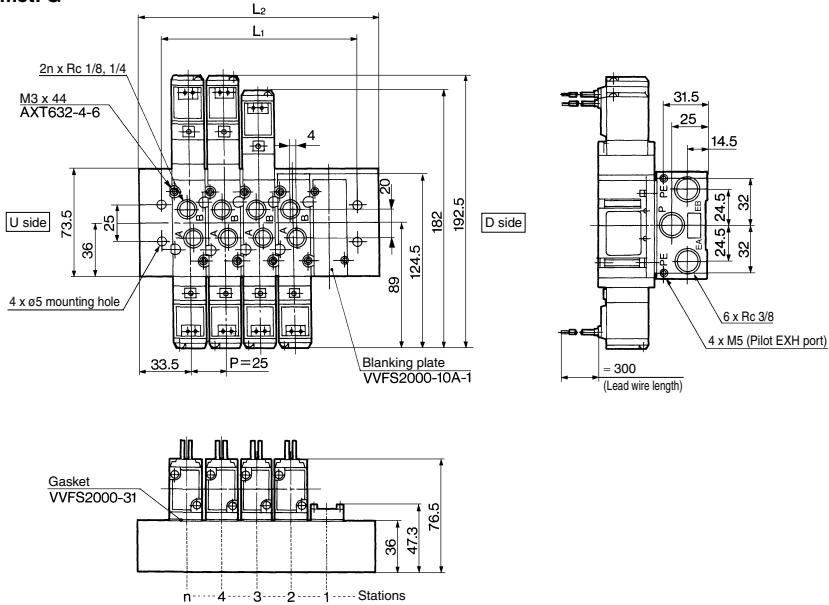

Formula for manifold weight  $M = 0.12n + 0.21$  (kg) n: Station

### Grommet terminal: E/EZ

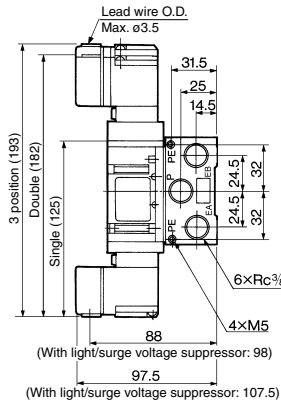

### Conduit terminal: T/TZ

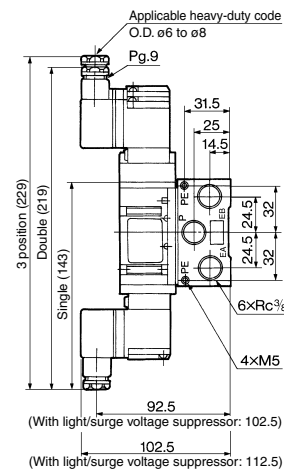

### DIN terminal: D/DZ/Y/YZ

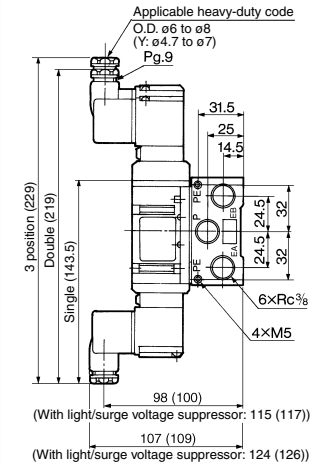

( ): Y, YZ  
n: Station

L	Stations	2	3	4	5	6	7	8	9	10	Formula
$L_1$		62	87	112	137	162	187	212	237	262	$L_1 = 25 \times n + 12$
$L_2$		92	117	142	167	192	217	242	267	292	$L_2 = 25 \times n + 42$

# 5 Port Pilot Operated Solenoid Valve Metal Seal, Body Ported

## VFS3000 Series



### Model

Type of actuation		Model		Port size Rc		Flow rate characteristics						Max. operating cycle (cpm) <sup>(1)</sup>	Response time (ms) <sup>(2)</sup>	Weight (kg) <sup>(3)</sup>
						1 → 4/2(P → A/B)			4/2 → 5/3(A/B → R1/R2)					
						C [dm <sup>3</sup> /(s·bar)]	b	Cv	C [dm <sup>3</sup> /(s·bar)]	b	Cv			
2 position	Single	VFS3120	VFS3130	1/4	5.0	0.20	1.1	6.8	0.30	1.7	1200	20 or less	0.33	
		3/8	6.1	0.14	1.4	7.3	0.23	1.8						
	Double	VFS3220	VFS3230	1/4	5.0	0.20	1.1	6.8	0.3	1.7	1500	15 or less	0.43	
		3/8	6.1	0.14	1.4	7.3	0.23	1.8						
3 position	Closed center	VFS3320	VFS3330	1/4	5.0	0.20	1.1	6.3	0.27	1.6	600	40 or less	0.45	
	3/8	5.7	0.20	1.4	6.8	0.21	1.7							
	Exhaust center	VFS3420	VFS3430	1/4	4.9	0.24	1.1	6.5	0.28	1.6	600	40 or less	0.45	
		3/8	5.8	0.15	1.4	7.0	0.22	1.7						
	Pressure center	VFS3520	VFS3530	1/4	4.9	0.23	1.1	6.6	0.28	1.6	600	40 or less	0.45	
		3/8	6.5	0.15	1.6	7.0	0.23	1.7						

Note 1) Based on JIS B 8419: 2010 (once per 30 days) for the minimum operating frequency.

Note 2) Based on JIS B 8419-2010. (The value at supply pressure 0.5 MPa, ambient/fluid temperature (= 20°C))

However, this excludes when in an adhered state. (Be aware that after long periods of holding time, there may be delays in the initial response time.)

Note 3) In the case of grommet type.

Note 4) Factors of "Note1)" and "Note 2)" are achieved in controlled clean air.

Compact yet provides a large flow capacity  
3/8: C: 6.8 dm<sup>3</sup>/(s·bar)

Low power consumption:  
1.8 W DC



### Symbol

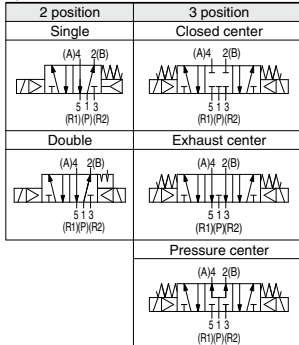

### Standard Specifications

Valve specifications	Fluid	Air	
	Maximum operating pressure	1.0 MPa	
	Minimum operating pressure	0.1 MPa	
	Proof pressure	1.5 MPa	
	Ambient and fluid temperature	-10 to 60°C <sup>(1)</sup>	
	Lubrication	Non-lube <sup>(2)</sup>	
	Pilot valve manual override	Non-locking push type (Flush)	
	Impact/Vibration resistance	150/50 m/s <sup>2</sup> <sup>(3)</sup>	
	Enclosure	Dustproof (Equivalent to IP50) <sup>(4)</sup>	
	Electricity specifications	Coil rated voltage	100, 200 VAC, 50/60 Hz; 24 VDC
Allowable voltage fluctuation		-15 to +10% of rated voltage	
Coil insulation type		Class B or equivalent (130°C) <sup>(5)</sup>	
Apparent power (Power consumption) AC		Inrush	5.6 VA/50 Hz, 5.0 VA/60 Hz
		Holding	3.4 VA (2.1 W)/50 Hz, 2.3 VA (1.5 W)/60 Hz
Power consumption		1.8 W (2.04 W: With light/surge voltage suppressor)	
Electrical entry		Grommet, Grommet terminal, Conduit terminal, DIN terminal	

Note 1) Use dry air at low temperatures.

Note 2) Use turbine oil Class 1 (ISO VG32), if lubricated.

Note 3) Impact resistance: No malfunction occurred when it is tested with a drop tester in the axial direction and at the right angles to the main valve and armature in both energized and de-energized states every once for each condition. (Values at the initial period)

Vibration resistance: No malfunction occurred in a one-sweep test between 45 and 2000 Hz. Test was performed at both energized and de-energized states in the axial direction and at the right angles to the main valve and armature. (Values at the initial period)

Note 4) Based on JIS C 0920.

Note 5) Based on JIS C 4003.

### Option Specifications

Pilot type	External pilot <sup>(1)</sup>
Pilot valve manual override	Non-locking push type (Extended), Locking type (Tool required)
Coil rated voltage	110 to 120, 220, 240 VAC (50/60 Hz)
	12, 100 VDC
Option	With light/surge voltage suppressor <sup>(2)</sup>
Foot bracket (With screw)	Part no.: VFS3000-S2A, VFS3120 (single) only

Note 1) Operating pressure: 0 to 1.0 MPa  
Pilot pressure: 0.1 to 1.0 MPa

Note 2) Grommet type is available only w/ surge voltage suppressor (which is directly connected with lead wire), not w/ indicator light.

### Manifold

Body type	Applicable manifold base	Pilot EXH
VFS3□20	Stacking manifold	Individual EXH (Valve side)
VFS3□30		Common EXH (Manifold base side)

How to Order

**VFS3 1 20 - 1 G - 02**

**Symbol**

1: 2 position single (A/B, 2B)  
2: position double (A/B, 2B)  
3: position closed center (A/B, 2B)  
4: position exhaust center (A/B, 2B)  
5: position pressure center (A/B, 2B)

**Option**

CE/UKCA-compliant  
NII —  
Q CE/UKCA-compliant

**Thread type**

NII	Rc
N*	NPT
T*	NPTF
F*	G

\* Semi-standard \* Mountable only for VFS3120.

**Port size**

02	1/4
03	3/8

**Manual override**

NII: Non-locking push type (Flush)	A*: Non-locking push type (Extended)	B*: Locking type (Tool required)
------------------------------------	--------------------------------------	----------------------------------

\* Semi-standard

**Light/Surge voltage suppressor**

NII	None
Z	With light/surge voltage suppressor
S*	With surge voltage suppressor

\* Grommet type is available only w/ surge voltage suppressor, not w/ indicator light.

**Electrical entry**

G: Grommet	E: Grommet terminal	T: Conduit terminal	D, Y: DIN terminal DO, YO: DIN terminal without connector
------------	---------------------	---------------------	--

**Body (Pilot exhaust)**

20: Individual EXH  
30\*: Common EXH

\* Manifold only

**Pilot type**

NII	Internal pilot
R*	External pilot

\* Semi-standard: it will be an individual external pilot.  
(External pilot port: Body side. For 30 type, common external pilot (on manifold side).)

**Coil rated voltage**

1	100 VAC (50/60 Hz)
2	200 VAC (50/60 Hz)
3*	110 to 120 VAC (50/60 Hz)
4*	220 VAC (50/60 Hz)
5	24 VDC
6*	12 VDC
7*	240 VAC (50/60 Hz)

\* Semi-standard (Note) No mounting bolts and gaskets are supplied with the valve single unit.  
For other rated voltages, please consult with SMC.

- SV
- SYJ
- SZ
- VF
- VP4
- VQ 1/2
- VQ 4/5
- VQC 1/2
- VQC 4/5
- VQZ
- SQ
- VFS
- VFR
- VQ7

How to Order Pilot Valve Assembly

**SF4 - 1 DZ - 21**

**Coil rated voltage**

1	100 VAC, 50/60 Hz
2	200 VAC, 50/60 Hz
3*	110 to 120 VAC (50/60 Hz)
4*	220 VAC, 50/60 Hz
5	24 VDC
6*	12 VDC
7*	240 VAC, 50/60 Hz

\* Semi-standard  
For other rated voltages, please consult with SMC.

**Electrical entry, Light/Surge voltage suppressor**

G	Grommet
GS	Grommet with surge voltage suppressor
D	DIN terminal
DZ*	DIN terminal with light/surge voltage suppressor
DO*	DIN terminal **
DOZ*	DIN terminal with light/surge voltage suppressor **
Y*	DIN terminal
YZ*	DIN terminal with light/surge voltage suppressor
YO*	DIN terminal **
YOZ*	DIN terminal with light/surge voltage suppressor **
T	Conduit terminal
TZ	Conduit terminal with light/surge voltage suppressor
E	Grommet terminal
EZ	Grommet terminal with light/surge voltage suppressor

**Manual override**

NII	Non-locking push type (Flush)
A*	Non-locking push type (Extended)
B*	Locking type (Tool required)

\* Semi-standard

**Applicable model**

14	A side pilot operator for VFS3:20	Individual pilot exhaust
15	B side pilot operator for VFS3220	
16	B side pilot operator for VFS3:20	Common pilot exhaust
17	A side pilot operator for VFS3:30	
18	B side pilot operator for VFS3230	
19	B side pilot operator for VFS3:30	

\* Y: Conforming to DIN43650B standard  
\*\* DIN connector is not attached.

# VFS3000 Series

## Cylinder Speed Chart

Use as a guide for selection.  
Please confirm the actual conditions with SMC Sizing Program.

### Body Ported

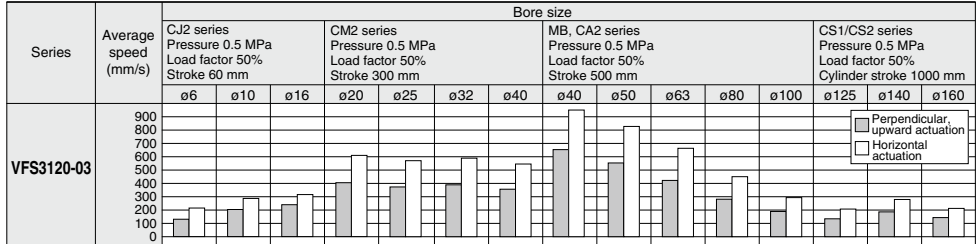

- \* It is when the cylinder is extending that is meter-out controlled by speed controller which is directly connected with cylinder, and its needle valve with being fully open.
- \* The average velocity of the cylinder is the value that the stroke is divided by the total stroke time.
- \* Load factor: ((Load mass x 9.8)/Theoretical force) x 100%

### Conditions

Body ported		CJ2 series	CM2 series	MB, CA2 series	CS1/CS2 series
VFS3120-03	Tube bore x Length	T0604 x 1 m	T1075 x 1 m	T1209 x 1 m	
	Speed controller	AS3001F-06	AS4001F-10	AS4001F-12	
	Silencer	AN20-02			AN202-02

## Construction

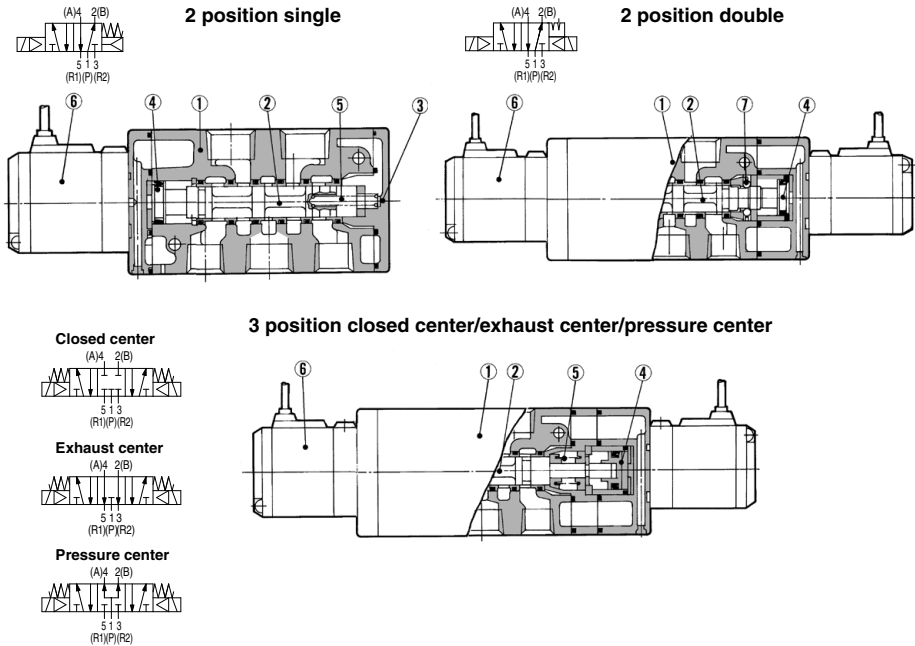

SV
SYJ
SZ
VF
VP4
VQ 1/2
VQ 4/5
VQC 1/2
VQC 4/5
VQZ
SQ
<b>VFS</b>
VFR
VQ7

## Component Parts

No.	Description	Material	Note
1	Body	Aluminum die-casted	—
2	Spool/Sleeve	Stainless steel	—
3	End plate	Resin	—
4	Piston	Resin	—
5	Return spring	Stainless steel	—
6	Pilot valve assembly	—	—
7	Detent assembly	—	—

\* Refer to "How to Order Pilot Valve Assembly" on page 903.

# VFS3000 Series

## 2 Position Single — Grommet, Grommet terminal, Conduit terminal, DIN terminal

Grommet: VFS3120-□G

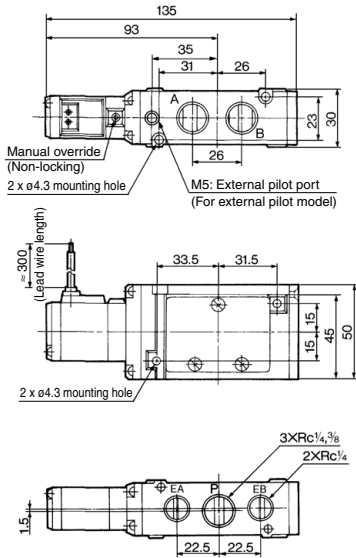

Foot bracket (F)  
Part no.: VFS3000-52A

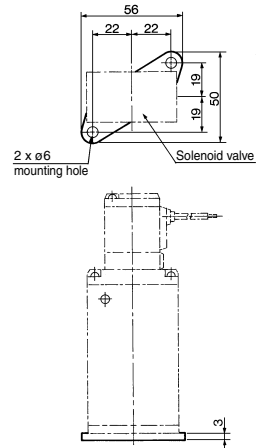

Grommet terminal: VFS3120-□E/EZ

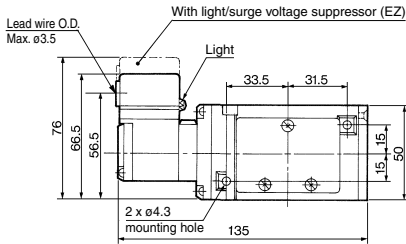

DIN terminal: VFS3120-□D/DZ/Y/YZ

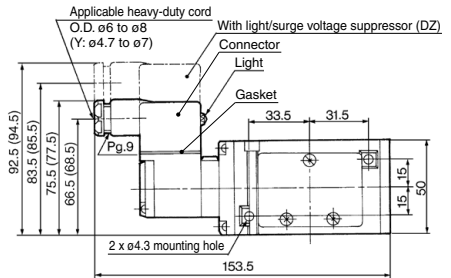

Conduit terminal: VFS3120-□T/TZ

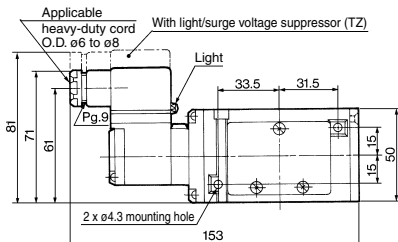

DIN Connector/Gasket Part No.

(): Y, YZ

Description	D(Z) type	Y(Z) type
Connector	B1B09-2A6	GMN209
Gasket	CAXT623-6-7-12	CAXT623-6-7-13



**2 Position Double, 3 Position — Grommet, Grommet terminal, Conduit terminal, DIN terminal**

**Grommet: VFS3220-□G, VFS3320-□G, VFS3420-□G, VFS3520-□G**

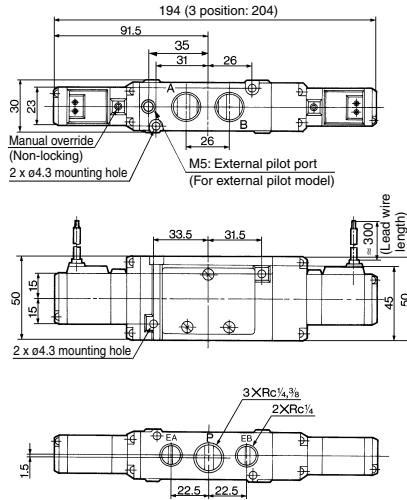

**Grommet terminal: VFS3220-□E/EZ VFS3320-□E/EZ  
VFS3420-□E/EZ VFS3520-□E/EZ**

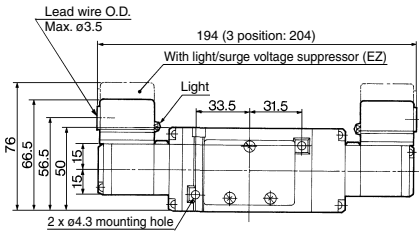

**Conduit terminal: VFS3220-□T/TZ VFS3320-□T/TZ  
VFS3420-□T/TZ VFS3520-□T/TZ**

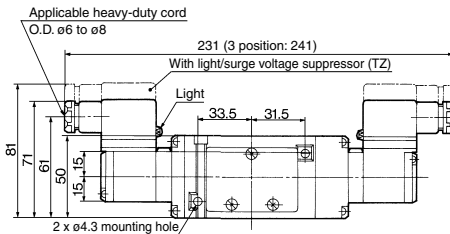

**DIN terminal: VFS3220-□D/DZ/Y/YZ  
VFS3320-□D/DZ/Y/YZ  
VFS3420-□D/DZ/Y/YZ  
VFS3520-□D/DZ/Y/YZ**

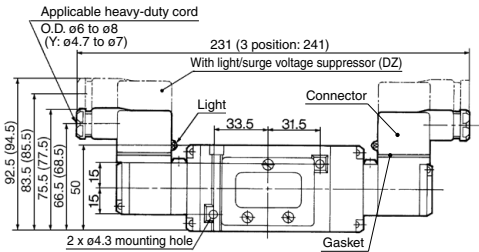

( ): Y, YZ

**DIN Connector/Gasket Part No.**

Description	D(Z) type	Y(Z) type
Connector	B1B09-2A6	GMN209
Gasket	CAXT623-6-7-12	CAXT623-6-7-13

# VFS3000 Series Manifold Specifications Stacking Type

## Keeps environmental air clean from pilot exhaust

Use of the VV5FS3-31 manifold can exhaust intensively the pilot exhaust gas to the base side, and can prevent environmental aggravation due to noise and oil mist.

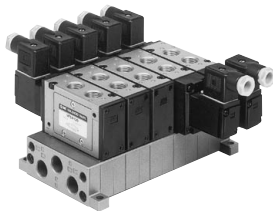

VV5FS3-31

Part no. for mounting bolt and gasket
BG-VFS3030

## Specifications

Manifold base type	Stacking type
Stations	Max. 15 stations

## Port Specifications

Symbol	Passage		Porting specifications		
	1(P)	3(R2), 5(R1)	Base 1(P)	Valve 2(B), 4(A)	Base 3(R2), 5(R1)
1	Common	Common	Side: (3/8)	Top: (1/4, 3/8)	Side: (3/8)

## Option

Blanking plate	VVFS3000-10A-1	With gasket, screw
SUP block plate	AXT636-10A	—
EXH block plate	AXT636-11A	—

Note) Individual SUP or EXH is possible with bottom porting of SUP or EXH. For your order, please indicate it in the manifold specification sheet.



## How to Order Manifold Base

**VV5FS3 - 31 - 05 1 - 03** - [ ] - [ ]

VFS3000 Series Manifold

- CE/UKCA-compliant**

Nil	—
Q	CE/UKCA-compliant
- Thread type**

Nil	Rc
N <sup>ø</sup>	NPT
T <sup>ø</sup>	NPTF
F <sup>ø</sup>	G

\* Semi-standard
- P, EA, EB port size**

03	3/8
----	-----
- Symbol**

	Passage		Porting specifications
	1(P)	3(R2), 5(R1)	2(B), 4(A)
1	Common 3/8	Common 3/8	Top 1/4, 3/8
- Stations**

02	2 stations
:	:
15	15 stations
- Base model**

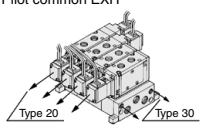
Model	Pilot exhaust	Applicable valve model
31	Pilot common EXH 	VFS3□20-□□-02-03 VFS3□30-□□-02-03

Note) Also VFS3□20 is possible to manifold. In this case, it uses an individual pilot exhaust.

## How to Order Manifold Assembly [Example]

Add the valve and option part numbers in order starting from the first station on the D side.

<Example>  
(Manifold base) VV5FS3-31-061-03 ..... 1  
(2 position single) \* VFS3130-1D-02 ..... 3  
(2 position double) \* VFS3230-1D-02 ..... 2  
(Blanking plate) \* VVFS3000-10A-1 ..... 1

The asterisk denotes the symbol for assembly. Prefix it to the part numbers of the solenoid valve.

**Manifold Base Construction — Body ported type**

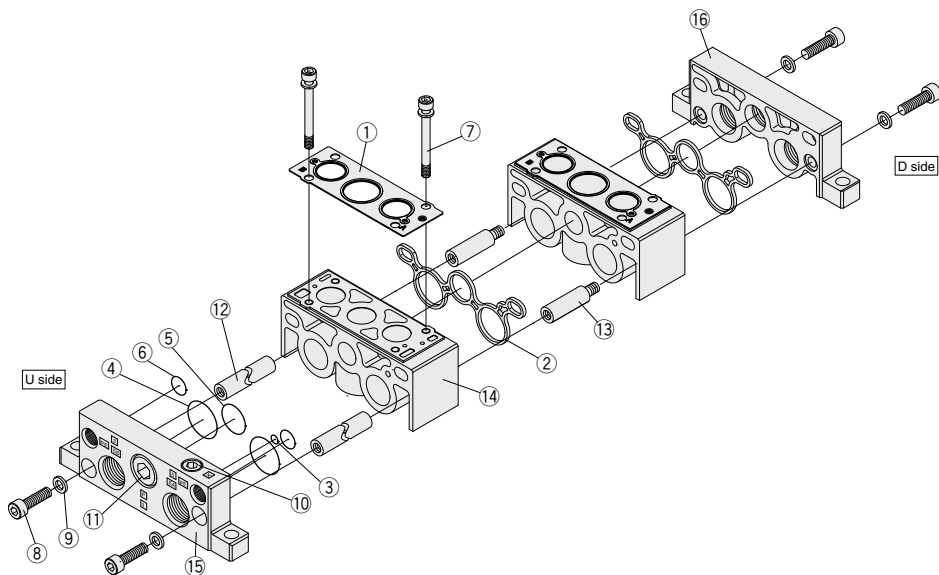

SV
SYJ
SZ
VF
VP4
VQ 1/2
VQ 4/5
VQC 1/2
VQC 4/5
VQZ
SQ
<b>VFS</b>
VFR
VQ7

**Replacement Parts**

No.	Description	Material	Part no.
1	Gasket	NBR	VVFS3000-31
2	Gasket	HNBR	VVFS3000-9-1H
3	O-ring	NBR	KA00175
4	O-ring	NBR	KA00358
5	O-ring	NBR	KA00291
6	O-ring	NBR	KA00336
7	Hexagon socket head cap screw	Carbon steel	AXT335-37-1#1
8	Hexagon socket head cap screw	Carbon steel	CA00746
9	Spring washer	Carbon steel	EC00022
10	Hexagon socket head taper plug	Carbon steel	TB00094
11	Hexagon socket head taper plug	Carbon steel	TB00155
12	Tie-rod	Carbon steel	VVFS3000-53- <small>(Stations)</small>
13	Tension bolt A	Carbon steel	VVFS3000-50-1 <sup>Note</sup>

Note) For increasing the manifold bases (included in the manifold block assembly)

- For increasing the manifold bases, please order the manifold block assembly number of the replacement parts assembly 14. (As the manifold block assembly includes the tension bolt A 13, it is not necessary to additionally order the tie-rod 12.)

**Replacement Parts: Sub Assembly**

No.	Description	Assembly part no.	Component parts
14	Manifold block assembly	VVFS3000-1A-30	Manifold block 14, Gasket 1, 2, Hexagon socket head cap screw 7, Tension bolt A 13.
15	End plate assembly (U side)	VVFS3000-2A-30	End plate (U) 15, O-ring 3, 4, 5, 6, Hexagon socket head cap screw 8, Spring washer 9, Hexagon socket head taper plug 10, 11
16	End plate assembly (D side)	VVFS3000-3A-30	End plate (U) 16, Hexagon socket head cap screw 7, Spring washer 9

# VFS3000 Series

## Type 31 Manifold — Pilot common exhaust: VV5FS3-31- Station 1-03

Grommet: G

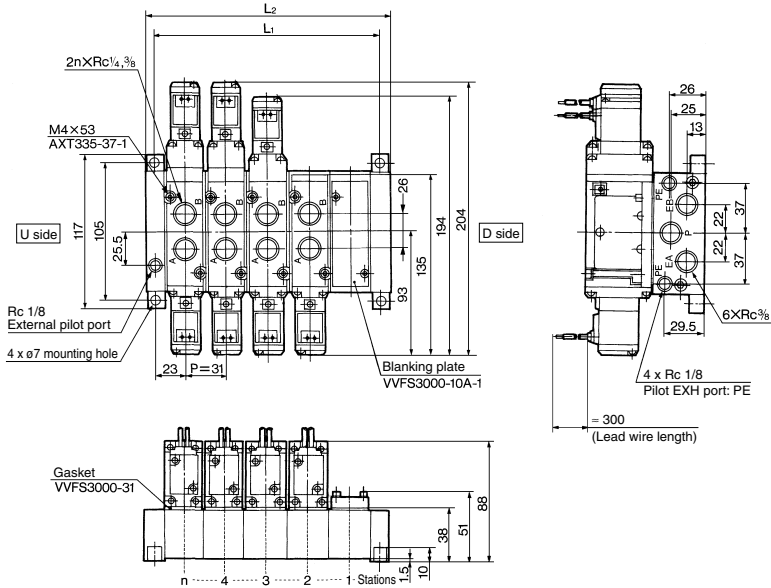

Formula for manifold weight  $M = 0.184n + 0.16$  (kg) n: Station

### Grommet terminal: E/EZ

### Conduit terminal: T/TZ

### DIN terminal: D/DZ/Y/YZ

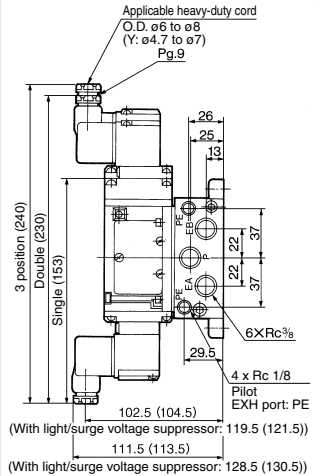
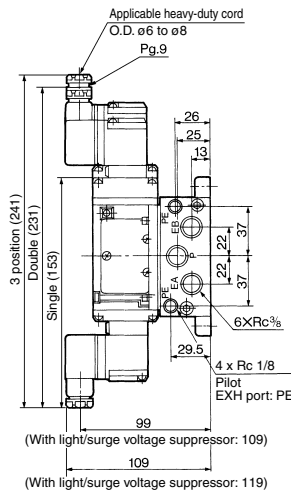
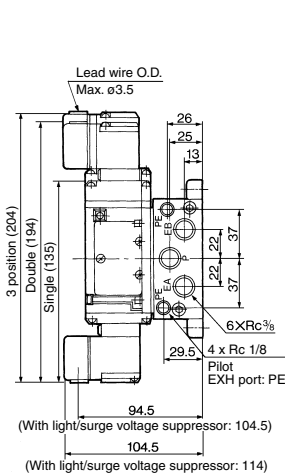

( ): Y, YZ

n: Station

Stations	2	3	4	5	6	7	8	9	10	Formula
L <sub>1</sub>	77	108	139	170	201	232	263	294	325	L <sub>1</sub> = 31 x n + 15
L <sub>2</sub>	92	123	154	185	216	247	278	309	340	L <sub>2</sub> = 31 x n + 30

<b>SV</b>
<b>SYJ</b>
<b>SZ</b>
<b>VF</b>
<b>VP4</b>
VQ 1/2
VQ 4/5
VQC 1/2
VQC 4/5
<b>VQZ</b>
<b>SQ</b>
<b>VFS</b>
<b>VFR</b>
<b>VQ7</b>

# 5 Port Pilot Operated Solenoid Valve Metal Seal, Body Ported

## VFS2000 Series



### How to Order

30 - VFS2 1 20 - 1 D - 01 -

Conforming to  
CSA standard

#### Symbol

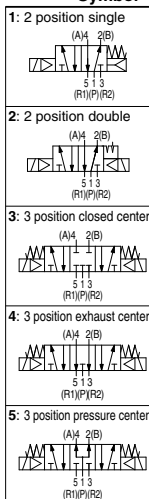

\* Reverse pressure: Can be used by external pilot specifications.

#### Body (Pilot exhaust)

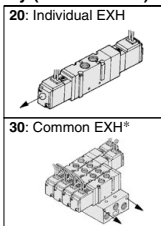

\* Manifold only

#### Pilot type

Nil	Internal pilot
R*	External pilot

\* Semi-standard: Individual external pilot (External pilot port: Body side)

#### Option

F: With foot bracket

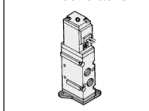

\* Mountable only for VFS2120.

#### Thread type

Nil	Rc
N*	NPT
T*	NPTF
F*	G

\* Semi-standard

#### Port size

01	1/8
02	1/4

#### Manual override

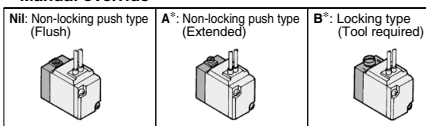

\* Semi-standard

#### Light/Surge voltage suppressor

Nil	None
Z	With light/surge voltage suppressor

#### Electrical entry

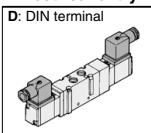

#### Coil rated voltage

1	100 VAC (50/60 Hz)
2	200 VAC (50/60 Hz)
3*	110 to 120 VAC (50/60 Hz)
4*	220 VAC (50/60 Hz)
5	24 VDC
6*	12 VDC
7*	240 VAC (50/60 Hz)

\* Semi-standard

Refer to standard products for specifications and dimensions.

# 5 Port Pilot Operated Solenoid Valve Metal Seal, Body Ported

## VFS3000 Series



### How to Order

30 - VFS3 1 20 - 1 D - 02 -

Conforming to CSA standard

#### Symbol

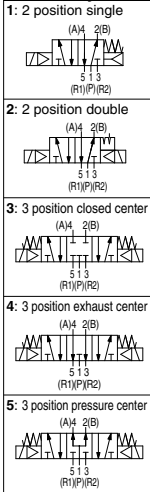

\* Reverse pressure: Can be used by external pilot specifications.

#### Body (Pilot exhaust)

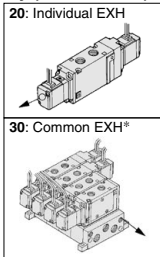

\* Manifold only

#### Pilot type

Nil	Internal pilot
R*	External pilot

\* Semi-standard: Individual external pilot (External pilot port: Body side. For 30 type, common external pilot (on manifold side).)

#### Thread type

Nil	Rc
N*	NPT
T*	NPTF
F*	G

\* Semi-standard

#### Option

F: With foot bracket

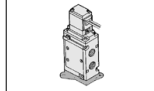

\* Mountable only for VFS3120.

#### Port size

02	1/4
03	3/8

#### Manual override

Nil: Non-locking push type (Flush)



\* Semi-standard

A\*: Non-locking push type (Extended)



B\*: Locking type (Tool required)



#### Light/Surge voltage suppressor

Nil	None
Z	With light/surge voltage suppressor

#### Electrical entry

D: DIN terminal

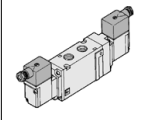

#### Coil rated voltage

1	100 VAC (50/60 Hz)
2	200 VAC (50/60 Hz)
3*	110 to 120 VAC (50/60 Hz)
4*	220 VAC (50/60 Hz)
5	24 VDC
6*	12 VDC
7*	240 VAC (50/60 Hz)

\* Semi-standard

SV  
SYJ  
SZ  
VF  
VP4  
VQ  
1/2  
VQ  
4/5  
VQC  
1/2  
VQC  
4/5  
VQZ  
SQ  
VFS  
VFR  
VQ7

Refer to Standard products for specifications and dimensions.

# 5 Port Pilot Operated Solenoid Valve Metal Seal, Plug-in/Non Plug-in

## VFS2000 Series



● VFS2000 series is compatible with the old models, VF2□00 and VF2□10 series.

(Details → P. 1004)

### Model

Type of actuation		Model		Port size Rc	Flow rate characteristics						Max. <sup>(1)</sup> operating cycle (cpm)	Response <sup>(2)</sup> time (ms)	Weight <sup>(3)</sup> (kg)
		Plug-in	Non plug-in		1 → 4/2(P → A/B)			4/2 → 5/3(A/B → R1/R2)					
					C [dm <sup>3</sup> /(s·bar)]	b	Cv	C [dm <sup>3</sup> /(s·bar)]	b	Cv			
2 position	Single	VFS2100	VFS2110	1/8	2.4	0.16	0.55	2.8	0.20	0.65	1200	15 or less	0.34
				1/4	2.5	0.18	0.58	2.8	0.21	0.65			
	Double	VFS2200	VFS2210	1/8	2.4	0.16	0.55	2.8	0.20	0.65	1200	13 or less	
				1/4	2.5	0.18	0.58	2.8	0.21	0.65			
3 position	Closed center	VFS2300	VFS2310	1/8	2.3	0.14	0.53	2.6	0.20	0.61	600	20 or less	0.43
				1/4	2.5	0.18	0.58	2.6	0.23	0.62			
	Exhaust center	VFS2400	VFS2410	1/8	2.4	0.15	0.54	2.7	0.25	0.63	600	20 or less	
				1/4	2.5	0.20	0.60	2.7	0.24	0.63			
	Pressure center	VFS2500	VFS2510	1/8	2.5	0.11	0.55	2.7	0.20	0.62	600	20 or less	
				1/4	2.8	0.17	0.63	2.7	0.22	0.63			
	Double check	VFS2600	VFS2610	1/8	1.2	—	—	1.3	—	—	600	25 or less	
				1/4	1.2	—	—	1.3	—	—			

Note 1) Based on JIS B 8419: 2010 (Once per 30 days) for the minimum operating frequency.

Note 2) Based on JIS B 8419-2010. (The value at supply pressure 0.5 MPa, ambient/fluid temperature (-20°C))  
However, this excludes when in an adhered state. (Be aware that after long periods of holding time, there may be delays in the initial response time.)

Note 3) Values for VFS2□00-□FZ-01.

Note 4) Factors of "Note 1)" and "Note 2)" are ones achieved in controlled clean air.

**Compact yet provides a large flow capacity**

1/4: C: 2.8 dm<sup>3</sup>/(s·bar)

**Low power consumption: 1.8 W DC**

**Easy maintenance**

2 types of sub-plates:

Plug-in and non plug-in

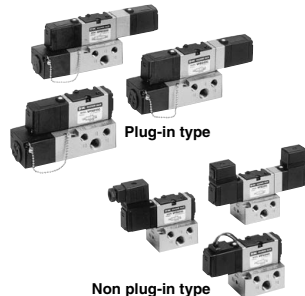

### Symbol

2 position	3 position
Single (AH 3B) 	Closed center (AH 3B) 
Double (AH 2B) 	Exhaust center (AH 2B) 
	Pressure center (AH 2B) 
	Double check (AH 2B) 

### Standard Specifications

	Fluid	Air	
Valve specifications	<b>Maximum operating pressure</b>		
	1.0 MPa		
	<b>Min. operating pressure</b>	2 position	0.1 MPa
		3 position	0.15 MPa
	<b>Proof pressure</b>		
	1.5 MPa		
	<b>Ambient and fluid temperature</b>		
	-10 to 60°C <sup>(1)</sup>		
	<b>Lubrication</b>		
	Non-lube <sup>(2)</sup>		
<b>Pilot valve manual override</b>			
Non-locking push type (Flush)			
<b>Impact/Vibration resistance</b>			
150/50 m/s <sup>2</sup> <sup>(3)</sup>			
<b>Enclosure</b>			
Type G, E: Dustproof (Equivalent to IP50), Type F, T, D: Splashproof (Equivalent to IP54) <sup>(4)(6)</sup>			
Electricity specifications	<b>Coil rated voltage</b>		
	100, 200 VAC, 50/60 Hz; 24 VDC		
	<b>Allowable voltage fluctuation</b>		
	-15 to +10% of rated voltage		
	<b>Coil insulation type</b>		
	Class B or equivalent (130°C) <sup>(6)</sup>		
	<b>Apparent power (Power consumption) AC</b>	Inrush	5.6 VA/50 Hz, 5.0 VA /60 Hz
Holding		3.4 VA (2.1 W)/50 Hz, 2.3 VA (1.5 W)/60 Hz	
<b>Power consumption DC</b>			
1.8 W (2.04 W: With light/surge voltage suppressor)			
<b>Electrical entry</b>	Plug-in type	Conduit terminal	
	Non plug-in type	Grommet terminal, DIN terminal	

Note 1) Use dry air at low temperatures. Note 2) Use turbine oil Class 1 (ISO VG32), if lubricated.

Note 3) Impact resistance: No malfunction occurred when it is tested with a drop tester in the axial direction and at the right angles to the main valve and armature in both energized and de-energized states every once for each condition. (Values at the initial period)

Vibration resistance: No malfunction occurred in a one-sweep test between 45 and 2000 Hz. Test was performed at both energized and de-energized states in the axial direction and at the right angles to the main valve and armature. (Values at the initial period)

Note 4) Based on JIS C 0920. Note 5) Based on JIS C 4003.

Note 6) The F type enclosure described above shows that without the light/surge voltage suppressor. The F type enclosure with the light/surge voltage suppressor is equivalent to IP50.

### Option Specifications

Pilot type	External pilot <sup>(Note)</sup>
<b>Manual override</b>	Non-locking push type (Extended), Locking type (Tool required), Locking type (Lever)
<b>Coil rated voltage</b>	110 to 120, 220, 240 VAC, 50/60 Hz
	12, 100 VDC
<b>Porting specifications</b>	Bottom ported
<b>Option</b>	With light/surge voltage suppressor

Note) Operating pressure: 0 to 1.0 MPa

Pilot pressure 2 position: 0.1 to 1.0 MPa 3 position: 0.15 to 1.0 MPa

### Compact, lightweight type sub-plate

Compared with the standard type, this is the sub-plate having the reduced external dimensions and lighter weight. But, use caution that Cv factor or piping port position is different from the standards. For details, refer to page 938.

Sub-plate	L (mm)	Weight (kg)	Sonic conduction <sup>(1)</sup> C [dm <sup>3</sup> /(s·bar)]
Standard type	31.0	0.2	2.2
Compact type	25.5	0.13	2.8

\* 2 position single Rc 1/4



# 5 Port Pilot Operated Solenoid Valve Metal Seal, Plug-in/Non Plug-in **VFS2000 Series**



## How to Order



With attachment plug lead wire



With terminal block

**Plug-in**

**Non plug-in**



**Symbol**

1	2 position single (A4, 2B)	
2	2 position double (A4, 2B)	
3	3 position closed center (A4, 2B)	
3	3 position exhaust center (A4, 2B)	
4	3 position pressure center (A4, 2B)	
5	3 position pressure center (A4, 2B)	
6	3 position double check (A4, 2B)	

**Porting specifications**

NII	Side ported
B*	Bottom ported

\* Semi-standard

**Option**

NII	None
Z	With light/surge voltage suppressor

**Body type**

O:	Plug-in type sub-plate
----	------------------------

**Electrical entry**

F:	Plug-in type
----	--------------

**Port size**

NII	Without sub-plate
01	1/8" Plug-in type conduit terminal (With terminal block) Standard type
02	1/4" Plug-in type conduit terminal (With attachment plug lead wire) Compact type

**Thread type**

NII	Rc
N*	NPT
T*	NPTF
F*	G

\* Semi-standard

Note) Please note Cv factor and piping port location of compact sub-plate is different from standard. Refer to page 938 for details.

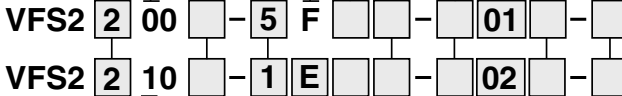

**Body type**

1:	Non plug-in type sub-plate
----	----------------------------

**Pilot type**

NII	Internal pilot
R*	External pilot

\* Semi-standard: External pilot can be mounted on only the sub-plate or manifold for the external pilot.

**Coil rated voltage**

1	100 VAC, 50/60 Hz
2	200 VAC, 50/60 Hz
3*	110 to 120 VAC, 50/60 Hz
4*	220 VAC, 50/60 Hz
5	24 VDC
6*	12 VDC
7*	240 VAC, 50/60 Hz

\* Semi-standard  
For other rated voltages, please consult with SMC.

**Pilot valve manual override**

NII:	Non-locking push type (Flush)
B*:	Locking type (Tool required)
A*:	Non-locking push type (Extended)
C*:	Locking type (Lever)

\* Semi-standard

**Option**

NII	None
Z	With light/surge voltage suppressor
S*	With surge voltage suppressor

\* Grommet type is available only w/ surge voltage suppressor, not w/ indicator light.

**Port size**

NII	Without sub-plate
01	1/8" Non plug-in type, Standard type
02	1/4" Non plug-in type, Compact type

Note) Please note Cv factor and piping port location of compact sub-plate is different from standard. Refer to page 938 for details.

**Electrical entry**

G:	Grommet
E:	Grommet terminal
T:	Conduit terminal
D, Y:	DIN terminal DO, YO: DIN terminal without connector

## How to Order Pilot Valve Assembly

SF4 - 1 [ ] - 20

**Coil rated voltage**

1	100 VAC, 50/60 Hz
2	200 VAC, 50/60 Hz
3*	110 to 120 VAC (50/60 Hz)
4*	220 VAC, 50/60 Hz
5	24 VDC
6*	12 VDC
7*	240 VAC, 50/60 Hz

\* Semi-standard  
For other rated voltages, please consult with SMC.

**Electrical entry, Light/Surge voltage suppressor**

F	Plug-in	Plug-in
G	Grommet	Non plug-in
GS	Grommet with surge voltage suppressor	
DZ	DIN terminal	
DZ	DIN terminal with light/surge voltage suppressor	
DO	DIN terminal*	
DOZ	DIN terminal with light/surge voltage suppressor*	
Y	DIN terminal	
YZ	DIN terminal with light/surge voltage suppressor	

**Manual override**

YO	DIN terminal*	Non plug-in
YOZ	DIN terminal with light/surge voltage suppressor*	
T	Conduit terminal	Non plug-in
ZZ	Conduit terminal with light/surge voltage suppressor	
E	Grommet terminal	
EZ	Grommet terminal with light/surge voltage suppressor	

\* DIN connector is not attached.  
\*\* Refer to page 1009 for voltage conversion.  
\*\*\* Y: Conforming to DIN43650B standard

**Option**

NII	Non-locking push type (Flush)
A*	Non-locking push type (Extended)
B*	Locking type (Tool required)
C*	Locking type (Lever)

\* Semi-standard

SV

SYJ

SZ

VF

VP4

VQ 1/2

VQ 4/5

VQC 1/2

VQC 4/5

VQZ

SQ

VFS

VFR

VQ7



# VFS2000 Series

## Cylinder Speed Chart

Use as a guide for selection.  
Please confirm the actual conditions with SMC Sizing Program.

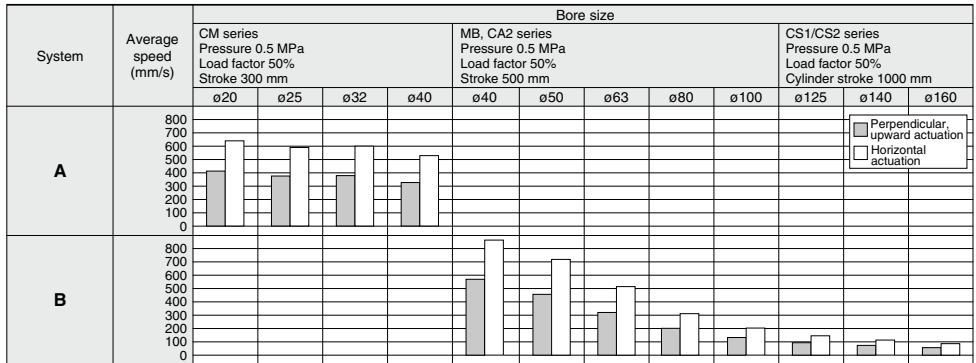

## System Components

System	Solenoid valve	Speed controller	Silencer	Tube bore x Length
A	VFS2000 Series Rc 1/8	AS3000-02 (S = 12 mm <sup>2</sup> )	AN110-01 (S = 35 mm <sup>2</sup> )	T0604 x 1 m
B	VFS2000 Series Rc 1/4	AS4000-02 (S = 21 mm <sup>2</sup> )	AN110-01 (S = 35 mm <sup>2</sup> )	T1075 x 1 m

- \* It is when the cylinder is extending that is meter-out controlled by speed controller which is directly connected with cylinder, and its needle valve will be fully open.
- \* The average velocity of the cylinder is the value that the stroke is divided by the total stroke time.
- \* Load factor: ((Load mass x 9.8)/Theoretical force) x 100%

## Double Check Spacer/Specifications

### Can hold an intermediate cylinder position for an extended time

If the double check spacer with a built-in double check valve is combined, it will enable the cylinder to stop in the intermediate stroke and maintain its position for a long time without being affected by the leakage between the spools.

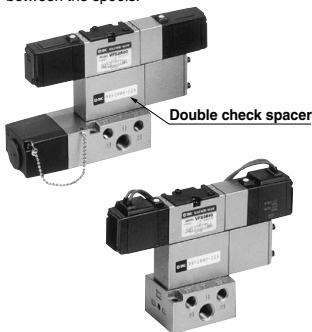

### Specifications

Double check spacer part no.	Plug-in type	Non plug-in type
	VVFS2000-22A-1	VVFS2000-22A-2
Applicable valve model	VFS2400-□F	VFS2410-□G □E □D

### ⚠ Caution

- In the case of 3 position double check valve (VFS26□0), check the leakage from piping and fittings in between valve and cylinder by means of synthetic detergent solutions, and ensure that there is no such leakage found there. Also check the leakage from cylinder seal and piston seal. If there is any leakage, sometimes the cylinder, when valve is de-energized, can move without stopping at intermediate position.
- Be aware that if the exhaust side is restricted excessively, the intermediate stopping accuracy will decrease and will lead to improper intermediate stops.
- Combining double check spacer with external pilot will not work.

### Check Valve Operating

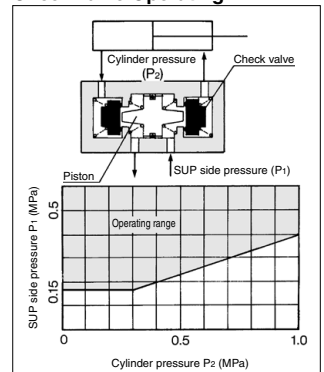

- The combination of VFS21<sup>0</sup>0, VFS22<sup>0</sup>0 and a double check spacer can be used as prevention of falling at the stroke end but cannot hold the intermediate position of the cylinder.

**Construction**

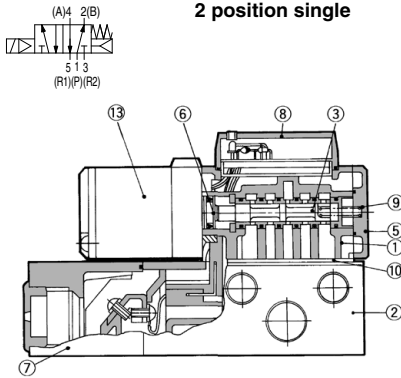

**2 position single**

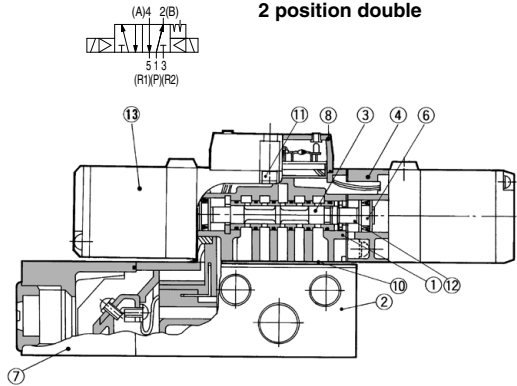

**2 position double**

**Closed center**

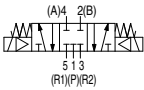

**Exhaust center**



**Pressure center**



**3 position closed center/exhaust center/pressure center**

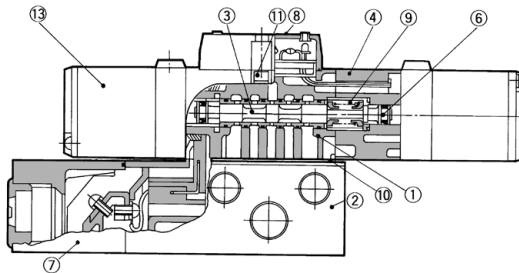

**Component Parts**

No.	Description	Material	Note
1	Body	Aluminum die-casted	—
2	Sub-plate	Aluminum die-casted	—
3	Spool/Sleeve	Stainless steel	—
4	Adapter plate	Resin	—
5	End plate	Resin	—
6	Piston	Resin	—
7	Junction cover	Resin	—
8	Cover	Resin	—
9	Return spring	Stainless steel	—
10	Gasket	HNBR	—
11	Hexagon socket head cap screw	Steel	—
12	Detent assembly	—	—
13	Pilot valve assembly	—	—

\* Refer to "How to Order Pilot Valve Assembly" on page 915.

**Sub-plate Assembly (Standard) Part No.**

Plug-in	VFS2000-LP- $\frac{01}{02}$ (N, T, F)
Non plug-in	VFS2000-LS- $\frac{01}{02}$ (N, T, F)

\* Mounting bolt and gasket are not included.

**Sub-plate Assembly (For External Pilot) Part No.**

Plug-in	VFS2000-LP-R- $\frac{01}{02}$ (N, T, F)
Non plug-in	VFS2000-LS-R- $\frac{01}{02}$ (N, T, F)

Part no. for mounting bolt and gasket	Note
BG-VFS2000	Plate gasket type (Earlier than September, 2012) <sup>Note</sup> 
BG-VFS2000-1	Groove gasket type (After October 2012) <sup>Note</sup> 

Note) When ordering the parts shown above for the replacement, note that the described date may slightly vary depending on the product being used.

SV
SYJ
SZ
VF
VP4
VQ 1/2
VQ 4/5
VQC 1/2
VQC 4/5
VQZ
SQ
VFS
VFR
VQ7

# VFS2000 Series

## Plug-in — 2 Position single/Double/3 Position closed center/Exhaust center/Pressure center/Double check

### 2 position single: VFS2100-□F(Z)-<sup>01</sup>/<sub>02</sub>

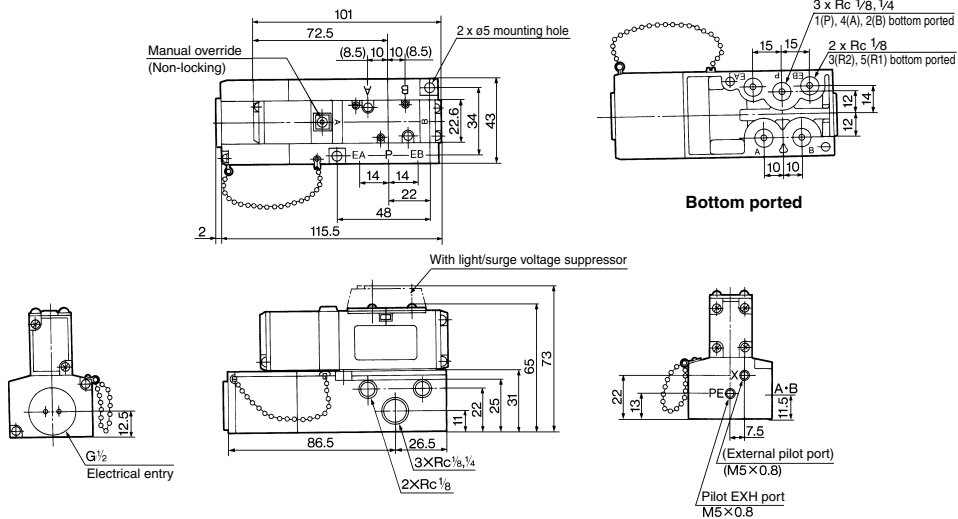

( ): Rc 1/8

### 2 position double: VFS2200-□F(Z)-<sup>01</sup>/<sub>02</sub>

### 3 position closed center: VFS2300-□F(Z)-<sup>01</sup>/<sub>02</sub>

### 3 position exhaust center: VFS2400-□F(Z)-<sup>01</sup>/<sub>02</sub>

### 3 position pressure center: VFS2500-□F(Z)-<sup>01</sup>/<sub>02</sub>

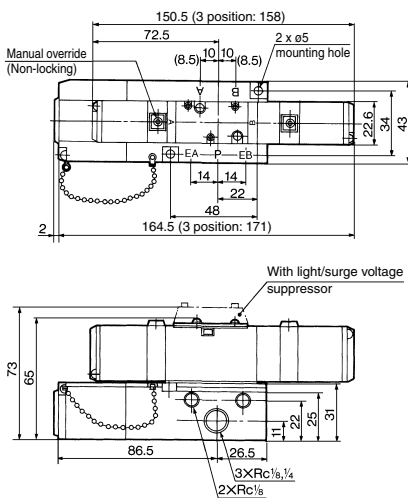

( ): Rc 1/8

### 3 position double check: VFS2600-□F(Z)-<sup>01</sup>/<sub>02</sub>

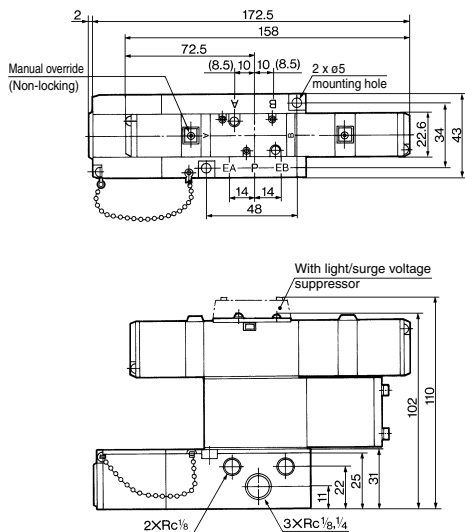

( ): Rc 1/8

**Non Plug-in — 2 Position single**

Grommet: VFS2110-□G(S)-01  
02

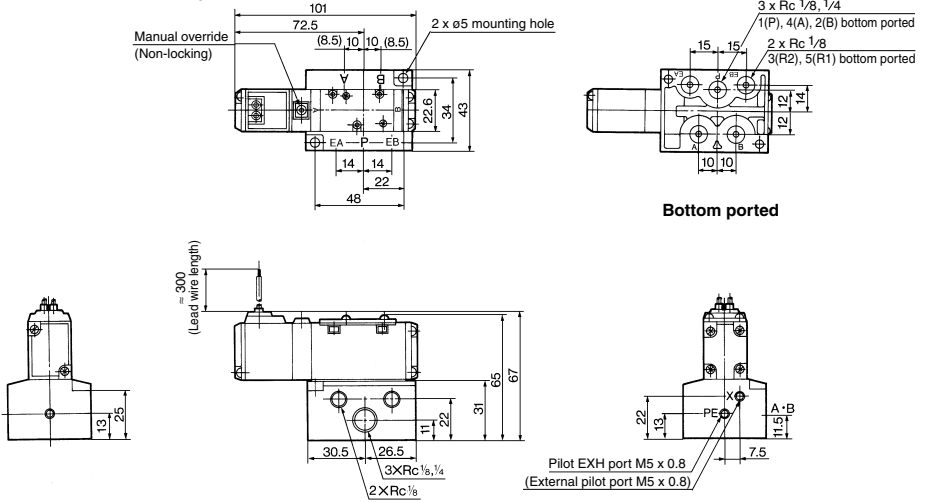

( ): Rc 1/8

Grommet terminal: VFS2110-□E(Z)-01  
02

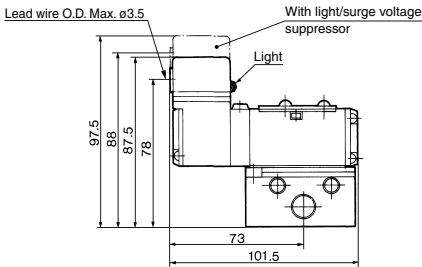

DIN terminal: VFS2110-□Y(Z)-01  
02

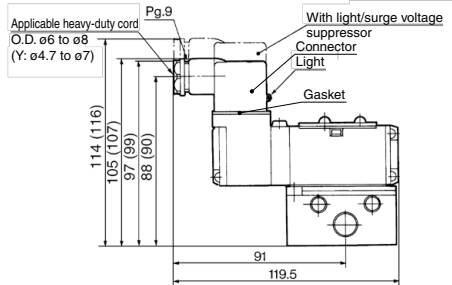

( ): Y, YZ

Conduit terminal: VFS2110-□T(Z)-01  
02

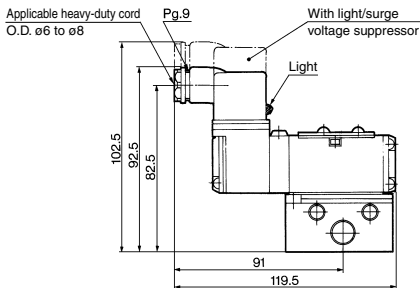

**DIN Connector/Gasket Part No.**

Description	D(Z) type	Y(Z) type
Connector	B1B09-2A6	GMN209
Gasket	CAXT623-6-7-12	CAXT623-6-7-13

# VFS2000 Series

## Non Plug-in — 2 Position double/3 Position closed center/Exhaust center/Pressure center

Grommet: Double VFS2210-□G(S)-<sup>01</sup>/<sub>02</sub>  
 Closed center VFS2310-□G(S)-<sup>01</sup>/<sub>02</sub>, Exhaust center VFS2410-□G(S)-<sup>01</sup>/<sub>02</sub>, Pressure center VFS2510-□G(S)-<sup>01</sup>/<sub>02</sub>

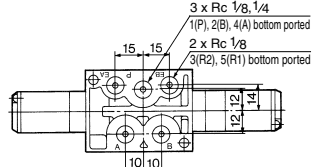
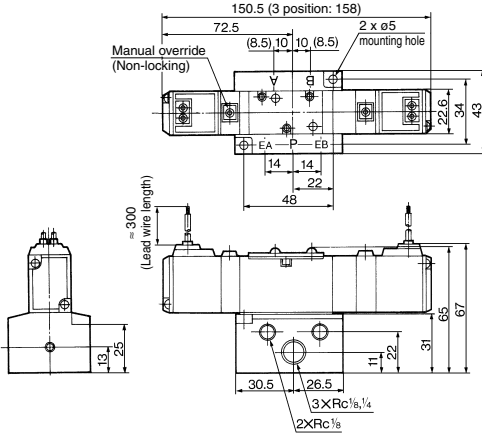

Bottom ported

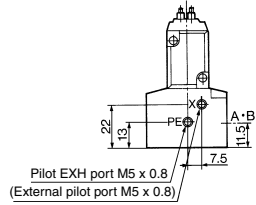

( ) : Rc 1/8

Grommet terminal: Double VFS2210-□E(Z)-<sup>01</sup>/<sub>02</sub>  
 Closed center VFS2310-□E(Z)-<sup>01</sup>/<sub>02</sub>  
 Exhaust center VFS2410-□E(Z)-<sup>01</sup>/<sub>02</sub>  
 Pressure center VFS2510-□E(Z)-<sup>01</sup>/<sub>02</sub>

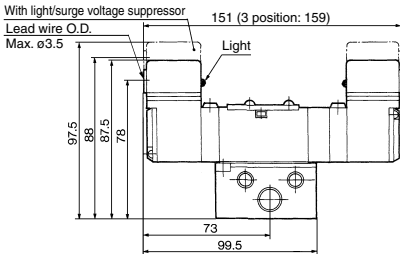

Conduit terminal: Double VFS2210-□T(Z)-<sup>01</sup>/<sub>02</sub>  
 Closed center VFS2310-□T(Z)-<sup>01</sup>/<sub>02</sub>  
 Exhaust center VFS2410-□T(Z)-<sup>01</sup>/<sub>02</sub>  
 Pressure center VFS2510-□T(Z)-<sup>01</sup>/<sub>02</sub>

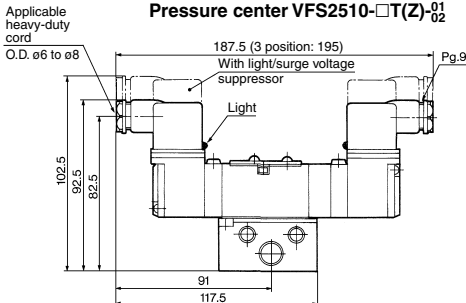

DIN terminal: Double VFS2210-□D(Y,Z)-<sup>01</sup>/<sub>02</sub>  
 Closed center VFS2310-□D(Y,Z)-<sup>01</sup>/<sub>02</sub>  
 Exhaust center VFS2410-□D(Y,Z)-<sup>01</sup>/<sub>02</sub>  
 Pressure center VFS2510-□D(Y,Z)-<sup>01</sup>/<sub>02</sub>

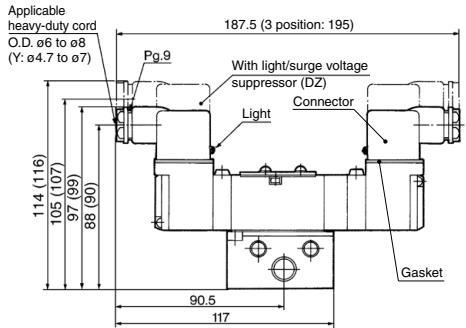

( ) : Y, YZ

### DIN Connector/Gasket Part No.

Description	D(Z) type	Y(Z) type
Connector	B1B09-2A6	GMN209
Gasket	CAXT623-6-7-12	CAXT623-6-7-13

**Non Plug-in — 3 Position double check**

**Grommet: VFS2610-□G(S)<sup>01</sup><sub>02</sub>**

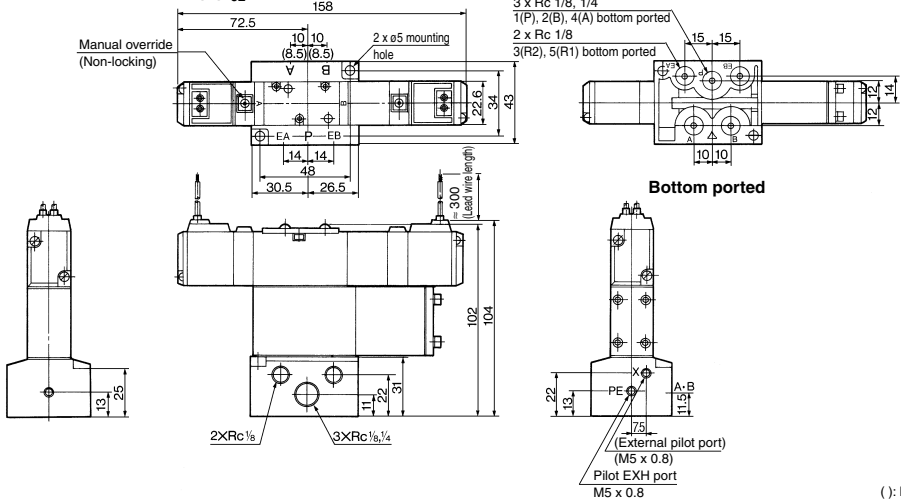

**Grommet terminal: VFS2610-□E(Z)<sup>01</sup><sub>02</sub>**

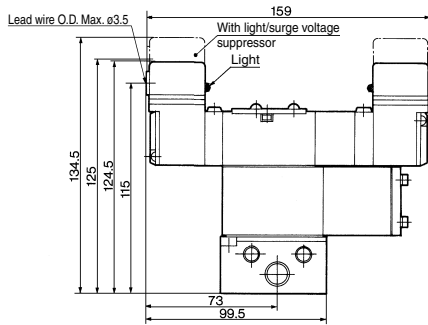

**DIN terminal: VFS2610-□P(Z)<sup>01</sup><sub>02</sub>**

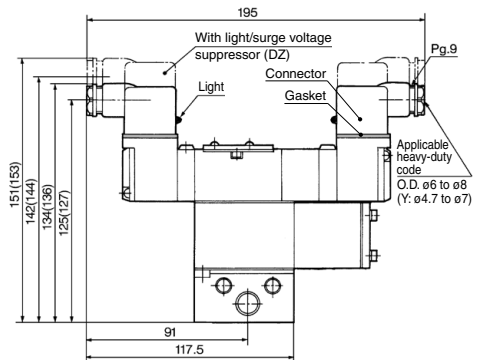

**Conduit terminal: VFS2610-□T(Z)<sup>01</sup><sub>02</sub>**

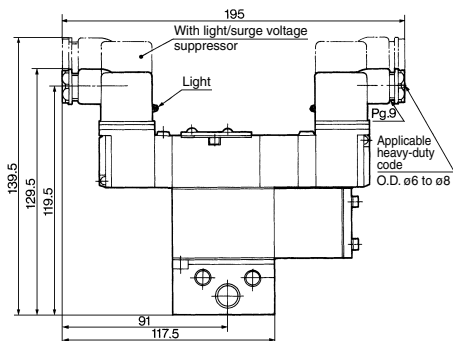

**DIN Connector/Gasket Part No.**

Description	D(Z) type	Y(Z) type
Connector	B1B09-2A6	GMN209
Gasket	CAXT623-6-7-12	CAXT623-6-7-13

## Manifold Specifications



### Plug-in Type: With Attachment Plug Lead Wire

The insert plug is attached to the manifold block and lead wire is plugged into the valve side. Please connect with corresponding power side.

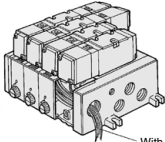

With attachment plug lead wire

VV5FS2-01-06 1-01

VFS2000 Series Manifold

Plug-in type  
With attachment plug lead wire

Stations  
01 1 station  
:  
:  
16 16 stations

CE/UKCA-compliant

Nil —  
Q CE/UKCA-compliant

Thread type

Nil Rc  
N\* NPT  
T\* NPTF  
F\* G  
\* Semi-standard

Symbol (Passage)

Symbol	Passage		Porting specifications A, B
	P	EA, EB	
1	Common	Common	Side
2 <sup>#</sup>			Bottom
3 <sup>#</sup>	Common	Individual	Side
4 <sup>#</sup>			Bottom
5 <sup>#</sup>	Individual	Common	Side
6 <sup>#</sup>			Bottom
7 <sup>#</sup>	Individual	Individual	Side
8 <sup>#</sup>			Bottom

Port size

Symbol	P, EA, EB	A, B
01	1/4	1/2
02	1/4	1/4
M	Mixed	

\* For bottom ported, 1/8 is only available.

\* Semi-standard

\* The external pilot type is not available.

### Plug-in Type: With Terminal Block

Since lead wires of solenoid valve are connected with the terminals on upper surface of terminal block, corresponding lead wires from power source can be wired at the bottom of terminal block.

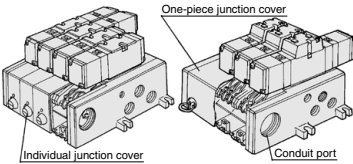

VV5FS2-01T -08 1-02

VFS2000 Series Manifold

Plug-in type  
With terminal block

Pilot type  
Nil Internal pilot  
R External pilot

Stations  
01 1 station  
:  
:  
16 16 stations

CE/UKCA-compliant

Nil —  
Q CE/UKCA-compliant

Thread type

Nil Rc  
N\* NPT  
T\* NPTF  
F\* G  
\* Semi-standard

Symbol (Passage)

Symbol	Passage		Porting specifications A, B	External pilot
	P	EA, EB		
1	Common	Common	Side	Yes
2 <sup>#</sup>			Bottom	
3 <sup>#</sup>	Common	Individual	Side	No
4 <sup>#</sup>			Bottom	
5 <sup>#</sup>	Individual	Common	Side	Yes
6 <sup>#</sup>			Bottom	
7 <sup>#</sup>	Individual	Individual	Side	No
8 <sup>#</sup>			Bottom	

Port size

Symbol	P, EA, EB	A, B
01	1/4	1/2
02	1/4	1/4
M	Mixed	

\* For bottom ported, 1/8 is only available.

\* Semi-standard

### Plug-in Type: With Multi-connector (Wiring specifications: Refer to page 1013.)

• Quick wiring permits ease of installation.

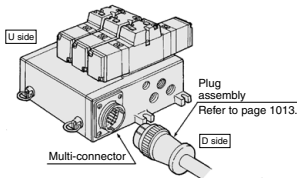

VV5FS2-01C D 1-05 2-01

VFS2000 Series Manifold

Plug-in type  
With multi-connector

Connector mounting direction  
D D side mounting  
U U side mounting

Stations  
01 1 station  
:  
:  
08 8 stations

CE/UKCA-compliant

Nil —  
Q CE/UKCA-compliant

Thread type

Nil Rc  
N\* NPT  
T\* NPTF  
F\* G  
\* Semi-standard

Symbol (Passage)

Symbol	Passage		Porting specifications A, B	External pilot
	P	EA, EB		
1	Common	Common	Side	Yes
2 <sup>#</sup>			Bottom	
3 <sup>#</sup>	Common	Individual	Side	No
4 <sup>#</sup>			Bottom	
5 <sup>#</sup>	Individual	Common	Side	Yes
6 <sup>#</sup>			Bottom	
7 <sup>#</sup>	Individual	Individual	Side	No
8 <sup>#</sup>			Bottom	

Port size

Symbol	P, EA, EB	A, B
01	1/4	1/2
02	1/4	1/4
M	Mixed	

\* For bottom ported, 1/8 is only available.

\* Semi-standard





[Option]

**Plug-in Type: With D-sub Connector** (Wiring specifications: Refer to page 1013.)

- Wide range of interchangeability (D-sub connector (25P) conforming to MIL standard)
- Quick wiring permits easier installation.

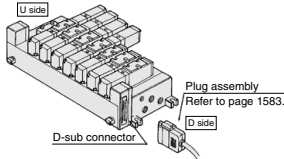

VV5FS2-01F D 1-06 1-01

VFS2000 Series Manifold  
Plug-in type  
With D-sub connector

Connector mounting direction  
D D side mounting  
U U side mounting

Stations  
01 1 station  
: :  
08 8 stations  
\* Max. 8 stations

CE/UKCA-compliant  
Nil -  
Q CE/UKCA-compliant

Thread type  
Nil Rc  
N<sup>s</sup> NPT  
T<sup>s</sup> NPTF  
F<sup>s</sup> G  
\* Semi-standard

Symbol	Passage		Porting specifications A, B	
	P	EA, EB	Side	Bottom
1			Side	
2 <sup>s</sup>	Common	Common	Side	Bottom
3 <sup>s</sup>			Side	
4 <sup>s</sup>	Common	Individual	Side	Bottom
5 <sup>s</sup>			Side	
6 <sup>s</sup>	Individual	Common	Side	Bottom
7 <sup>s</sup>			Side	
8 <sup>s</sup>	Individual	Individual	Side	Bottom

Port size  
Symbol P, EA, EB, A, B  
01 1/4 1/8  
M 1/4 Mixed

\* For bottom ported, 1/8 is only available.

\* Semi-standard  
\* The external pilot type is not available.

- SV
- SYJ
- SZ
- VF
- VP4
- VQ 1/2
- VQ 4/5
- VQC 1/2
- VQC 4/5
- VQZ
- SQ
- VFS
- VFR
- VQ7

**Non Plug-in Type: Grommet, Grommet Terminal, Conduit Terminal, DIN Terminal**

- Wiring for every valve

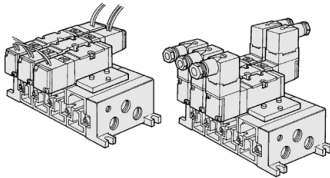

VV5FS2-10 10 2-02

VFS2000 Series Manifold  
Non plug-in type

Pilot type  
Nil Internal pilot  
R External pilot

Stations  
01 1 station  
: :  
16 16 stations

CE/UKCA-compliant  
Nil -  
Q CE/UKCA-compliant

Thread type  
Nil Rc  
N<sup>s</sup> NPT  
T<sup>s</sup> NPTF  
F<sup>s</sup> G  
\* Semi-standard

Symbol	Passage		Porting specifications A, B		External pilot
	P	EA, EB	Side	Bottom	
1			Side		Yes
2 <sup>s</sup>	Common	Common	Side	Bottom	
3 <sup>s</sup>	Common	Individual	Side	Bottom	No
4 <sup>s</sup>			Side		
5 <sup>s</sup>	Individual	Common	Side	Bottom	Yes
6 <sup>s</sup>			Side		
7 <sup>s</sup>	Individual	Individual	Side	Bottom	No
8 <sup>s</sup>			Side		

Port size  
Symbol P, EA, EB, A, B  
01 1/4 1/8  
02 1/4 1/8  
M 1/4 Mixed

\* For bottom ported, 1/8 is only available.

\* Semi-standard

Note) The individual specification of the P port at the composition symbol 3 to 8 or the EA, EB, ports should be taken as individual port using a block plate. Therefore, if an individual port is using a single SUP spacer of option or a single EXH spacer, the composition symbol mark is "1".

**How to Order Manifold Assembly**

Please indicate manifold base type, corresponding valve, and option parts.

<Example>

- Plug-in type with terminal block (6 stations, one-piece type junction cover) (Manifold base) VV5FS2-01T1-061-02-... 1 (2 position single) VFS2100-5FZ-... 3 (2 position double) VFS2200-5FZ-... 2 (Blanking plate) VVFS2000-10A-... 1
- Non plug-in type (6 stations) (Manifold base) VV5FS2-10-061-01-... 1 (2 position single) VFS2110-5D-... 3 (3 position exhaust center) VFS2410-5D-... 3 (Individual EXH spacer) VVFS2000-R-01-2-... 1

**Manifold Specifications**

Base model	Wiring	Porting specifications		Port size Rc	Stations	Applicable valve model
		A, B port	P, EA, EB, A, B			
Plug-in type VV5FS2-01□	<ul style="list-style-type: none"> <li>• With attachment plug lead wire</li> <li>• With terminal block</li> <li>• With multi-connector</li> <li>• With D-sub connector</li> </ul>	Side/Bottom	1/4	1/8, 1/4	2 to 15 <sup>s</sup> stations	VFS2□□00-□F
Non plug-in type VV5FS2-10	<ul style="list-style-type: none"> <li>• Grommet</li> <li>• Grommet terminal</li> <li>• Conduit terminal</li> <li>• DIN terminal</li> </ul>					VFS2□□10-□G VFS2□□10-□E VFS2□□10-□T VFS2□□10-□D

\* With multi-connector, with D-sub connector: 8 stations at the maximum.

**Flow Rate Characteristics at the Number of Manifold Stations (Operated individually)**

Model	Passage/Stations	Station 1	Station 5	Station 10	
VV5FS2	1 → 4/2 (P → A/B)	C [dm <sup>3</sup> ]/(s-bar)	2.4	2.4	2.4
		b	0.14	0.14	0.14
		Cv	0.50	0.50	0.50
	4/2 → 5/3 (A/B → R1/R2)	C [dm <sup>3</sup> ]/(s-bar)	2.5	2.5	2.5
		b	0.18	0.18	0.18
		Cv	0.60	0.60	0.60

\* Port size Rc 1/4



# VFS2000 Series

## Manifold Option Parts Assembly

### Individual SUP spacer

An individual SUP spacer set on manifold block can form SUP port for every valve.

Body type	Plug-in type	Non plug-in type
Standard type	Rc 1/8 VVFS2000-P-01-1	VVFS2000-P-01-2
	Rc 1/4 VVFS2000-P-02-1	VVFS2000-P-02-2
External pilot	Rc 1/8 VVFS2000R-P-01-1	VVFS2000R-P-01-2
	Rc 1/4 VVFS2000R-P-02-1	VVFS2000R-P-02-2

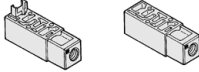

### Individual EXH spacer

An individual EXH spacer set on manifold block can form EXH port for every valve. (Common EXH type)

Body type	Plug-in type	Non plug-in type
Standard type	Rc 1/8 VVFS2000-R-01-1	VVFS2000-R-01-2
	Rc 1/4 VVFS2000-R-02-1	VVFS2000-R-02-2
External pilot	Rc 1/8 VVFS2000R-R-01-1	VVFS2000R-R-01-2
	Rc 1/4 VVFS2000R-R-02-1	VVFS2000R-R-02-2

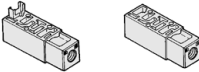

### SUP block plate

When supplying manifold with more than two different pressures, high and low, insert a block plate in between stations subjected to different pressures.

Body type	Plug-in type	Non plug-in type
Part no.	AXT625-12A	

Note) The SUP and EXH block plates cannot be used for the 2 stations integrated type manifold block.

### EXH block plate

When valve exhaust affects the other stations on the circuit or when the reverse pressure valve is used to standard manifold valve, insert EXH block plate in between stations to separate valve exhaust.

Body type	Plug-in type	Non plug-in type
Part no.	AXT625-12A	



### Throttle valve spacer

Needle valve set on the manifold block can control cylinder speed by throttling exhaust.

Body type	Plug-in type	Non plug-in type
Part no.	VVFS2000-20A-1	VVFS2000-20A-2

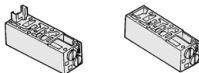

### Interface regulator (P port regulation)

Interface regulator set on manifold block can regulate the pressure to each valve. Refer to "Flow Rate Characteristics" on page 1011.

Body type	Plug-in type	Non plug-in type
P port regulation	ARBF2000-00-P-1	ARBF2000-00-P-2

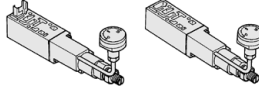

### Air shutoff valve spacer

When stopping supply air and releasing residual pressure after completion of work, actuators may move from original position. Air shut off valve spacer makes it possible to stop actuators in original position for extended periods.

\* Not applicable to the external pilot.

Body type	Plug-in type	Non plug-in type
Part no.	VVFS2000-21A-1	VVFS2000-21A-2



\* Not mountable for standard type sub-plate.

### Air release valve spacer

The concurrent use of air release valve spacer with VFS21□0 (single) can release air.

Body type	Plug-in type	Non plug-in type
Part no.	VVFS2000-24A-1 $\frac{1}{8}$	VVFS2000-24A-2 $\frac{1}{4}$

Note) L: U side mount R: D side mount

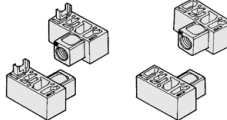

### Double check spacer

If the double check spacer with a built-in double check valve is combined, it will enable the cylinder to stop in the intermediate stroke and maintain its position for a long time without being affected by the leakage between the spools.

\* Not applicable to the external pilot.

Body type	Plug-in type	Non plug-in type
Part no.	VVFS2000-22A-1	VVFS2000-22A-2

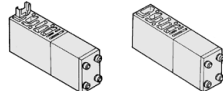

### Blanking plate

It is used by attaching on the manifold block for being prepared for removing a valve for maintenance reasons or planning to mount a spare valve, etc.

Body type	Plug-in type	Non plug-in type
Part no.	VVFS2000-10A	

### Accessory

Each gasket and one set of mounting screws with a length for one stack are supplied with the option parts assembly.

## Manifold Option

### With control unit

#### Plug-in type/Non plug-in type

- Filter, regulation valve, pressure switch and air release valve are all combined to form one unit.
- Piping processes are eliminated.

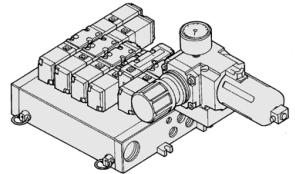

For details, refer to page 929.

### Drip-proof Manifold

#### Plug-in type

- Equivalent to IP65

For details, refer to page 931.

### Made to Order

#### Manifold with serial transmission kit Plug-in type

- Solenoid valve wiring process reduced considerably.

For details, refer to page 934.

**Manifold — Plug-in type, Non plug-in type**

**Plug-in type (Insert plug with lead wire): VV5FS2-01-Station 1-Port size**

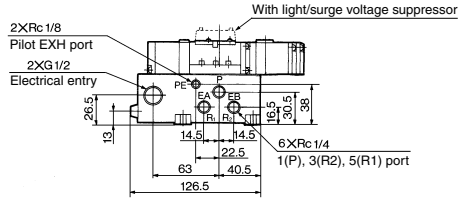
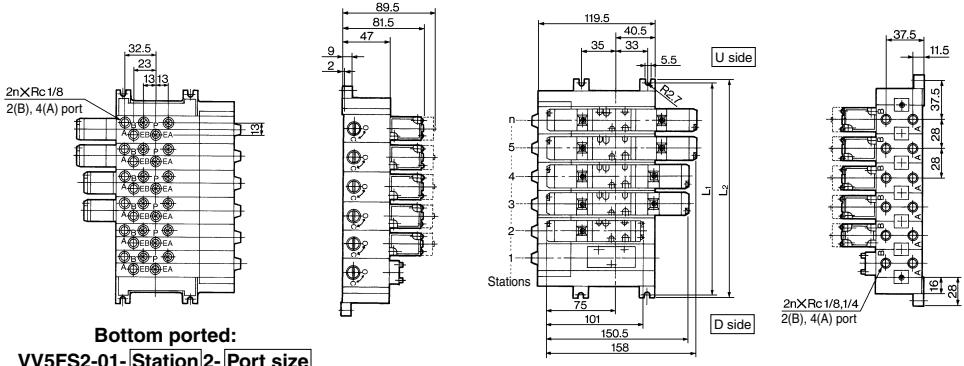

Formula for manifold weight  $M = 0.201n + 0.299$  (kg) n: Station

**Non plug-in type: VV5FS2-10-Station 1-Port size**

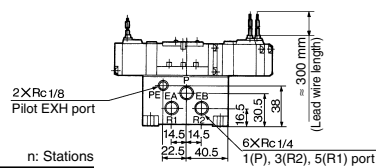
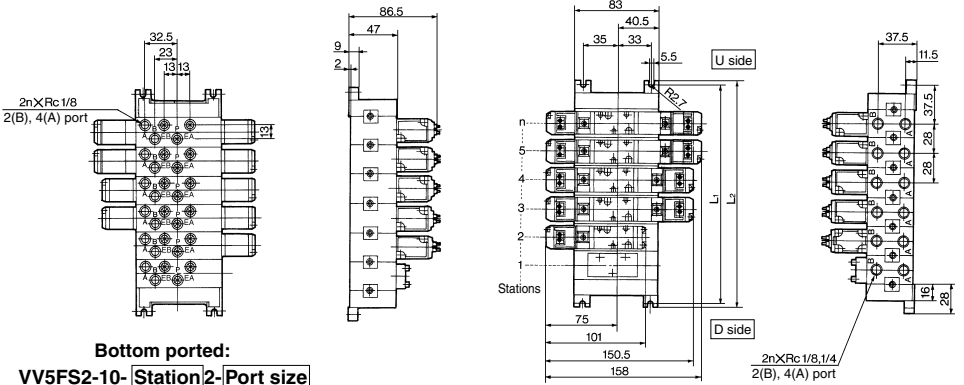

Formula for manifold weight  $M = 0.174n + 0.218$  (kg)

n: Stations

Station	1	2	3	4	5	6	7	8	9	10	Formula
L <sub>1</sub>	75	103	131	159	187	215	243	271	299	327	L <sub>1</sub> = 28 x n + 47
L <sub>2</sub>	84	112	140	168	196	224	252	280	308	336	L <sub>2</sub> = 28 x n + 56

- SV
- SYJ
- SZ
- VF
- VP4
- VQ 1/2
- VQ 4/5
- VQC 1/2
- VQC 4/5
- VQZ
- SQ
- VFS
- VFR
- VQ7

# VFS2000 Series

## Manifold — Plug-in type: Individual/One-piece junction cover

### Plug-in type with terminal block (Individual junction covers): VV5FS2-01T- Station 1- Port size

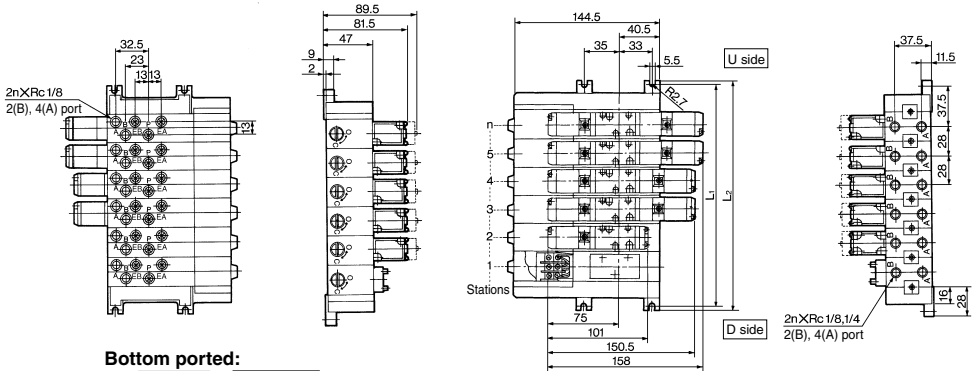

Bottom ported:  
VV5FS2-01T-Station 2-Port size

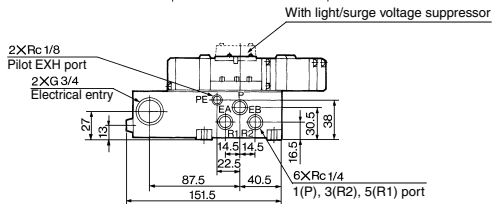

Formula for manifold weight  $M = 0.215n + 0.35$  (kg) n: Station

### Plug-in type with terminal block (One-piece junction covers): VV5FS2-01T1- Station 1- Port size

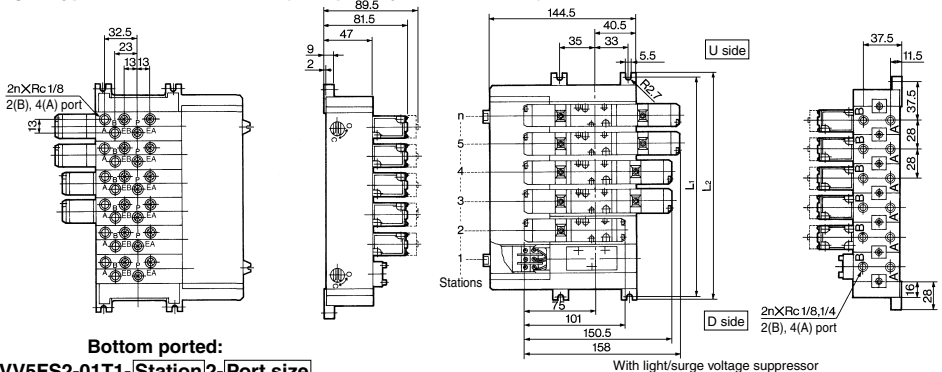

Bottom ported:  
VV5FS2-01T1-Station 2-Port size

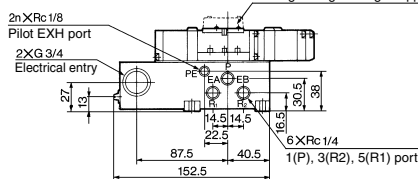

Formula for manifold weight  $M = 0.236n + 0.354$  (kg) n: Station

L	1	2	3	4	5	6	7	8	9	10	Formula
L <sub>1</sub>	75	103	131	159	187	215	243	271	299	327	L <sub>1</sub> = 28 x n + 47
L <sub>2</sub>	84	112	140	168	196	224	252	280	308	336	L <sub>2</sub> = 28 x n + 56

**Manifold — Plug-in with multi-connector/with D-sub connector**

Plug-in with multi-connector: VV5FS2-01CD1-Station1-Port size, VV5FS2-01CU1-Station1-Port size

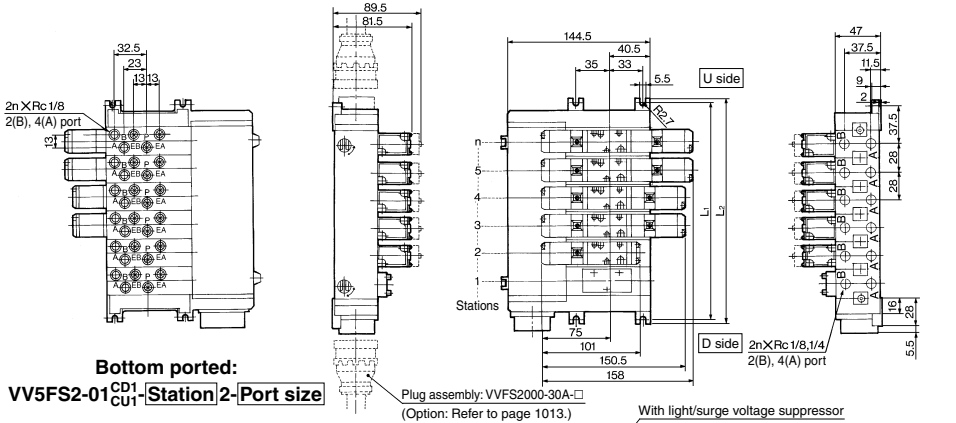

Formula for manifold weight  $M = 0.211n + 0.442$  (kg) n: Station  
\* Wiring specifications: Refer to page 1013.

Plug-in type with D-sub connector: VV5FS2-01FD1-Station1-Port size, VV5FS2-01FU1-Station1-Port size

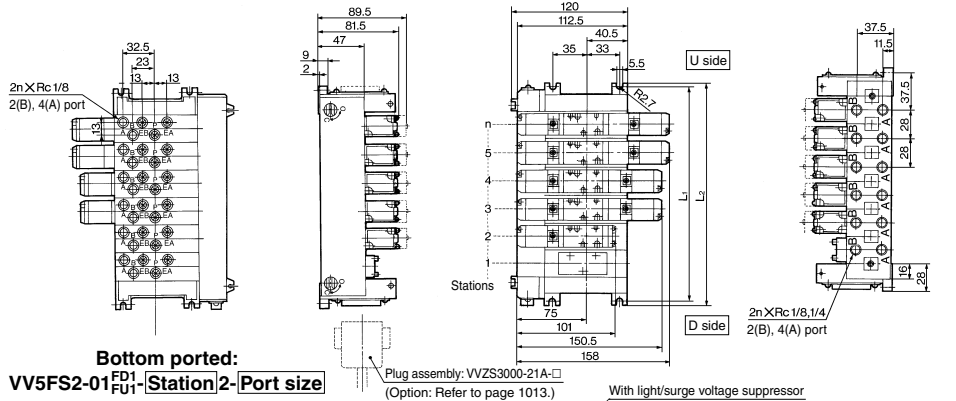

Formula for manifold weight  $M = 0.178n + 0.378$  (kg)  
\* Wiring specifications: Refer to page 1013.

Station	1	2	3	4	5	6	7	8	Formula
L <sub>1</sub>	75	103	131	159	187	215	243	271	L <sub>1</sub> = 28 x n + 47
L <sub>2</sub>	84	112	140	168	196	224	252	280	L <sub>2</sub> = 28 x n + 56

- SV
- SYJ
- SZ
- VF
- VP4
- VQ 1/2
- VQ 4/5
- VQC 1/2
- VQC 4/5
- VQZ
- SQ
- VFS
- VFR
- VQ7

# VFS2000 Series

## Manifold Option Parts — Plug-in type, Non plug-in type

### Individual SUP spacer:

VVFS2000(R)-P-0<sub>1</sub>-1 (Plug-in type)

VVFS2000(R)-P-0<sub>2</sub>-2 (Non plug-in type)

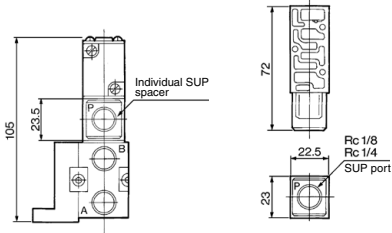

### Interface regulator:

ARBF2000-00-P-1 (Plug-in type)

ARBF2000-00-P-2 (Non plug-in type)

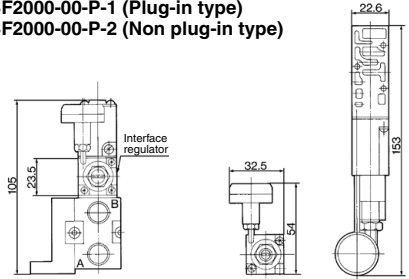

### Individual EXH spacer:

VVFS2000(R)-R-0<sub>1</sub>-1 (Plug-in type)

VVFS2000(R)-R-0<sub>2</sub>-2 (Non plug-in type)

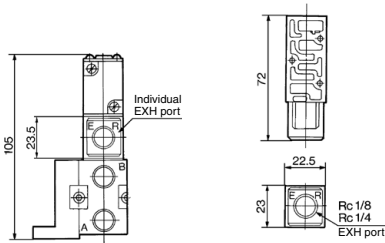

### Air shutoff valve spacer:

VVFS2000-21A-1 (Plug-in type)

VVFS2000-21A-2 (Non plug-in type)

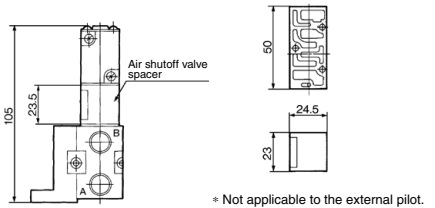

SUP block plate: AXT625-12A

EXH block plate: AXT625-12A

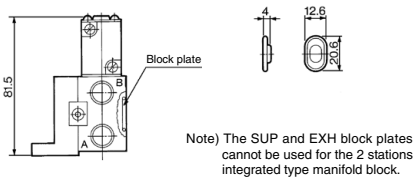

### Release valve spacer:

VVFS2000-24A-1<sup>□</sup> (Plug-in type)

VVFS2000-24A-2<sup>□</sup> (Non plug-in type)

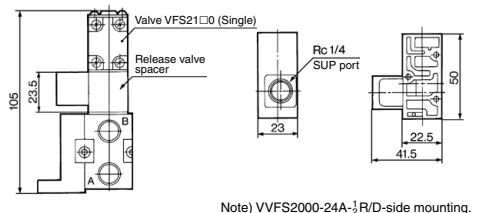

### Throttle valve spacer:

VVFS2000-20A-1 (Plug-in type)

VVFS2000-20A-2 (Non plug-in type)

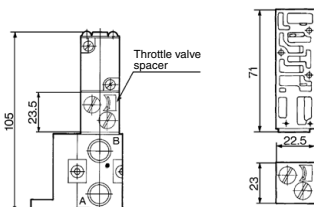

### Double check spacer:

VVFS2000-22A-1 (Plug-in type)

VVFS2000-22A-2 (Non plug-in type)

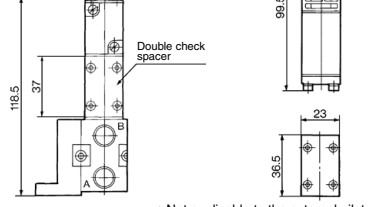

# Manifold with Control Unit

- Control unit (Filter, Regulator, Pressure switch, Air release valve) are all standardized to the one unit, and can be mounted on the manifold base without any attachments.
- Piping processes are eliminated.



Plug-in type

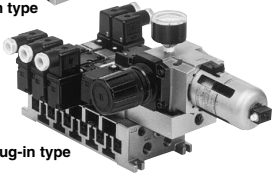

Non plug-in type

### Caution

When using an air filter with auto-drain or manual drain, mount the filter vertically.

## Manifold Specifications

Manifold	Plug-in type: VV5FS2-01□	Non plug-in type: VV5FS2-10
<b>Wiring</b>	Plug-in with attachment plug lead wire With terminal block With multi-connector With D-sub connector	Grommet Grommet terminal Conduit terminal DIN terminal
<b>Applicable valve model</b>	VFS2□00-□□F (Z)	VFS2□10-□□G, VFS2□10-□□E VFS2□10-□□T, VFS2□10-□□D
<b>Porting specifications</b>	Common SUP, Common EXH	
	2(B), 4(A) port	Side: 1/8, 1/4, Bottom: 1/8 (Option)
<b>Rc</b>	1 (P), 3(R2), 5(R1) port	Side: 1/4, 1/8, Bottom: 1/8 (Option)
<b>Stations</b>	2 to 15 stations*	

\* With multi-connector, or D-sub connector: 8 stations max.

## Control Unit Specifications

<b>Air filter (With auto-drain/With manual drain)</b>	
<b>Filteration degree</b>	5 μm
<b>Regulator</b>	
<b>Set pressure (Outlet pressure)</b>	0.05 to 0.85 MPa
<b>Pressure switch (1)</b>	
<b>Set pressure range: OFF</b>	0.1 to 0.6 MPa
<b>Differential</b>	0.08 MPa or less
<b>Contact</b>	1a
<b>Indicator light</b>	LED (RED)
<b>Max. switch capacity</b>	2 VA AC, 2 W DC
<b>Max. operating current</b>	24 VAC/DC or less: 50 mA 100 VAC/DC: 20 mA
<b>Air release valve (Single only)</b>	
<b>Operating pressure range</b>	0.1 to 1.0 MPa

## Control Unit/Option

<b>Air release valve spacer</b>	<Plug-in type>	VVFS2000-24A-1R (D side mounting) VVFS2000-24A-1L (U side mounting)
	<Non plug-in type>	VVFS2000-24A-2R (D side mounting) VVFS2000-24A-2L (U side mounting)
<b>Pressure switch (1)</b>	IS100P-2-1	
<b>Blanking plate</b>	With control unit/Filter regulator	MP2-2
	Pressure switch	MP3-2
	Release valve	AXT625-18A
<b>Filter element</b>	111511-5B	
<b>Regulator with filter</b>	Manually operated	INA-13-794G
	Auto-drain type	INA-13-806G

Note 1) Voltage: 24 VDC to 100 VAC  
Inner voltage drop: 4 V

Note 2) Refer to manifold option parts on page 924.

Note 3) The non plug-in type cannot be mounted afterwards.

## How to Order

Note) The manifold of plug-in type with attachment plug lead wire is applied to individual type only.  
Non plug-in type has no junction cover.



**VV5FS2 - 10 - 08 1 - 01 - AP -**

**VFS2000 Series Manifold**

**Base type/Electrical entry**

<b>01</b>	Plug-in type with attachment plug lead wire
<b>01T</b>	Plug-in type with terminal block
<b>01C</b>	Plug-in type with multi-connector
<b>01F</b>	Plug-in type with D-sub connector
<b>10</b>	Non plug-in type

**Connector mounting direction**

Symbol	With connector	Applicable base
<b>Nil</b>	None	01, 01T, 10
<b>D</b>	D side mounting	01C, 01F
<b>U</b>	U side mounting	

**Junction cover**

Nil	Stacking type
<b>1</b>	Integrated type

Note) Stacking type:  
Base type 01, 01T  
Integrated type:  
Base type 01T, 01C, 01F

**Stations**

<b>02</b>	2 stations
⋮	⋮
<b>15*</b>	15 stations

\* Base type  
01, 01T, 10 → 2 to 15 stations  
01C, 01F → 2 to 8 stations

**Symbol**

Symbol	Passage		Porting specifications
	P	EA, EB	B, A
<b>1</b>			Side
<b>2*</b>	Common	Common	Bottom
<b>3*</b>			Side
<b>4*</b>	Common	Individual	Bottom
<b>5*</b>			Side
<b>6*</b>	Individual	Common	Bottom
<b>7*</b>			Side
<b>8*</b>	Individual	Individual	Bottom

\* Semi-standard  
The individual specification of the P port in the composition symbol marks 3 to 8 or EA, EB ports should be taken as individual port using a block plate. Therefore, if an individual port is taken using a single SUP spacer of option or a single EXH spacer, the composition symbol mark is "1".

**Thread type**

<b>Nil</b>	Rc
<b>N*</b>	NPT
<b>T*</b>	NPTF
<b>F*</b>	G

\* Semi-standard

**Port size**

Symbol	P, EA, EB	B, A
<b>01</b>		1/8
<b>02</b>	1/4	1/4
<b>M</b>		Mixed

**CE/UKCA-compliant**

<b>Nil</b>	—
<b>Q</b>	CE/UKCA-compliant

**Air release valve coil rating**

<b>Nil</b>	None (F, G type only)
<b>1</b>	100 VAC, 50/60 Hz
<b>5</b>	24 VDC
<b>9</b>	Other

**Control unit type**

Control equipment	Nil	A	AP	M	MP	F	G	C	E
Air filter with auto-drain	●	●							
Air filter with manual drain				●	●	●	●		
Regulator		●	●	●	●	●	●		
Air release valve		●	●	●	●			●	●
Pressure switch				●					
Blanking plate (Air release valve)							●	●	
Blanking plate (Filter, Regulator)								●	●
Blanking plate (Pressure switch)		●	●	●	●	●	●		
Number of manifold blocks required for mounting (stations)	2	2	2	2	2	2	2	2	1

**How to Order Manifold Assembly [Example]**

Add the valve and option part numbers in order starting from the first station on the D side.

**<Example>**

- Plug-in type with terminal block (Manifold base) VV5FS2-01T-091-02-MP5 ... 1 (2 position single) \* VFS2100-5FZ ... 5 (2 position double) \* VFS2200-5FZ ... 2 \* 2 stations are needed to mount control unit.
- Non plug-in type (Manifold base) VV5FS2-10-071-01-M ... 1 (2 position single) \* VFS2110-5D ... 5 \* 2 stations are needed to mount control unit.

The asterisk denotes the symbol for assembly. Prefix it to the part numbers of the solenoid valve.

SV

SYJ

SZ

VF

VP4

VQ

1/2

VQ

4/5

VQC

1/2

VQC

4/5

VQZ

SQ

VFS

VFR

VQ7

# VFS2000 Series

## Manifold with Control Unit — Plug-in type, Non plug-in type

Plug-in type:

VVFS2-01T-Station 1- Port size- Control unit Voltage for release valve

Example for manifold

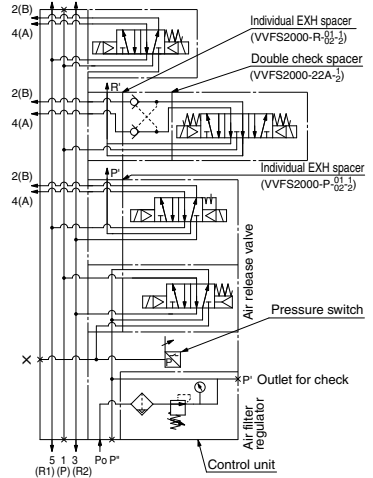
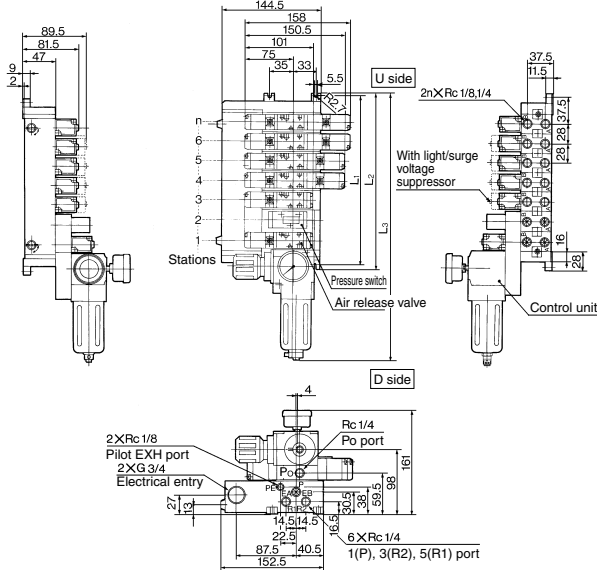

Non plug-in type:

VVFS2-10-Station 1- Port size- Control unit Voltage for release valve

Example for manifold

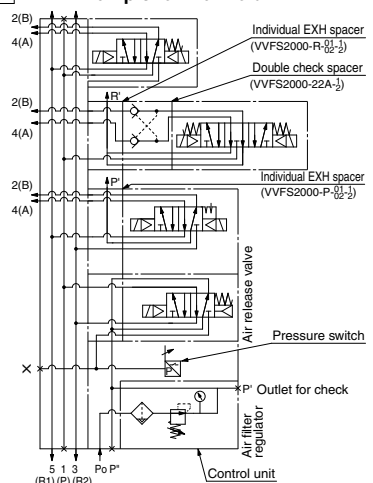
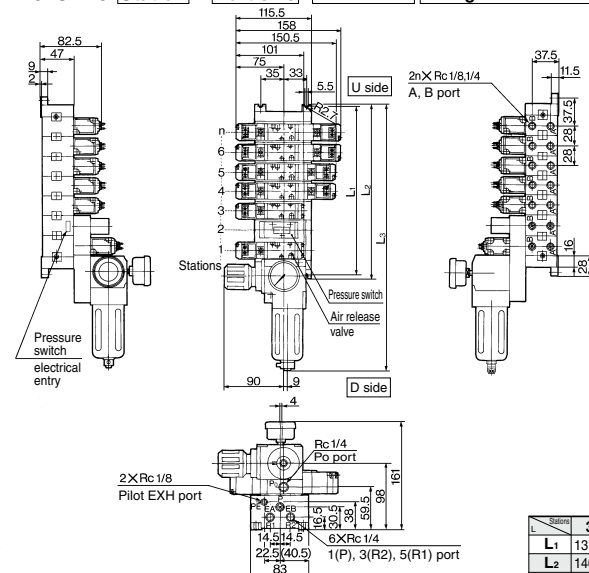

n: Stations

L	3	4	5	6	7	8	9	10	Formula
L <sub>1</sub>	131	159	187	215	243	271	299	327	L <sub>1</sub> = 28 x n + 47
L <sub>2</sub>	140	168	196	224	252	280	308	336	L <sub>2</sub> = 28 x n + 56
L <sub>3</sub> (MP)	278	306	334	362	390	418	446	474	L <sub>3</sub> = 28 x n + 194
L <sub>3</sub> (AP)	319.5	347.5	375.5	403.5	431.5	459.5	487.5	515.5	L <sub>3</sub> = 28 x n + 235.5



# Dripproof Manifold (Equivalent to IP65)

## Manifold Specifications

Manifold	VV5FS2-01WTB□	VV5FS2-01W
Wiring	Common terminal box	Attachment plug lead wire
Applicable value model	VFS2□00-□F-X54	
Porting specifications Rc	Common SUP, Common EXH	
	2(B), 4(A) port	Side: 1/8, 1/4, Bottom: 1/8 (Option)
	1(P), 3(R2), 5(R1) port	Side: 1/4
Stations	2 to 10 stations	2 to 15 stations



## How to Order

### How to order manifold

VV5FS2 - **01WTBU** - **08** **1** - **02** - □

Plug-in dripproof manifold  
(Equivalent to IP65)

<b>01WTBU</b>	Common terminal box (U side mounting)
<b>01WTBD</b>	Common terminal box (D side mounting)
<b>01W</b>	Attachment plug lead wire

#### Stations

<b>02</b>	2 stations
⋮	⋮
<b>15</b>	15 stations

\* For 01WTB□, please specify the number of stations mounted on the valve.  
(2 stations mounted on the terminal block are not included.)

#### CE/UKCA-compliant

<b>NII</b>	—
<b>Q</b>	CE/UKCA-compliant

#### Port size

Symbol	P, R1, R2	A, B
<b>01</b>	—	1/8
<b>02</b>	1/4	1/4
<b>M</b>	—	Mixed

\* For bottom ported, A/B port is available only with 1/8.

#### Symbol

Symbol	Passage P, R1, R2	Porting specifications A, B
<b>1</b>	—	Side
<b>2*</b>	Common	Bottom

\* Semi-standard

### How to order valves

VFS2 **1** **00** □ - **5** **F** □ □ - **X54** - □

#### Symbol

<b>1</b>	2 position single
<b>2</b>	2 position double
<b>3</b>	3 position closed center
<b>4</b>	3 position exhaust center
<b>5</b>	3 position pressure center
<b>6</b>	3 position double check

#### Pilot type

<b>NII</b>	Internal pilot
<b>R*</b>	External pilot

\*Semi-standard

#### CE/UKCA-compliant

<b>NII</b>	—
<b>Q</b>	CE/UKCA-compliant

#### Dripproof

#### Pilot valve manual override

<b>NII</b>	Non-locking push type (Flush)
<b>A*</b>	Non-locking push type (Extended)
<b>B*</b>	Locking type (Tool required)
<b>C*</b>	Locking type (Lever)

\* Semi-standard

#### Option

<b>NII</b>	None
<b>Z</b>	With light/surge voltage suppressor

#### Coil rated voltage

<b>1</b>	100 VAC, 50/60 Hz
<b>2</b>	200 VAC, 50/60 Hz
<b>3*</b>	110 to 120 VAC, 50/60 Hz
<b>4*</b>	220 VAC, 50/60 Hz
<b>5</b>	24 VDC
<b>6*</b>	12 VDC
<b>7*</b>	240 VAC, 50/60 Hz

\* Semi-standard  
For other rated voltages, please consult with SMC.

# VFS2000 Series

## Dripproof Manifold

With common terminal box: VV5FS2-01WTB **Station 1- Port size**

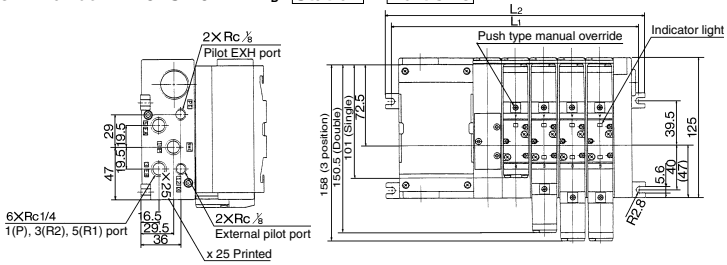

Bottom ported: VV5FS2-01WTBD **Station 2-01**

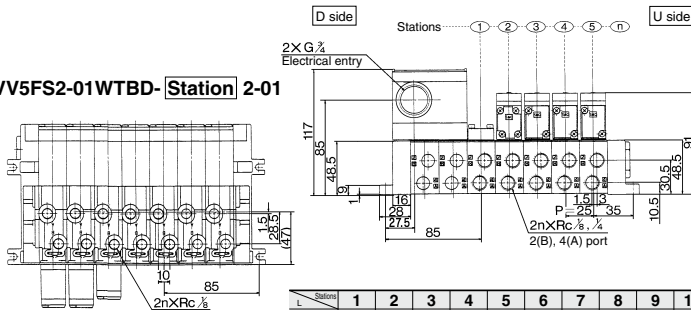

\* Terminal mounting stations are not included.  
Indicates solenoid valve mounting stations.

Station	1	2	3	4	5	6	7	8	9	10	Formula
L <sub>1</sub>	120	145	170	195	220	245	270	295	320	345	L <sub>1</sub> = 25 x n + 95
L <sub>2</sub>	131	156	181	206	231	256	281	306	331	356	L <sub>2</sub> = 25 x n + 106

With attachment plug lead wire: VV5FS2-01W **Station 1- Port size**

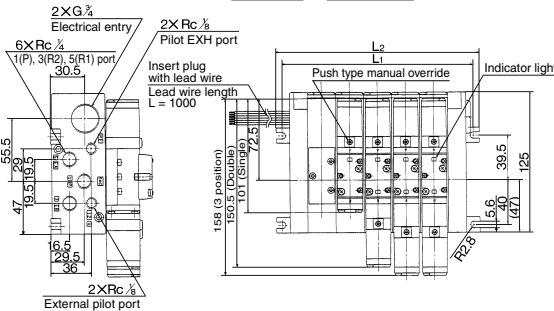

Bottom ported: VV5FS2-01W **Station 2-01**

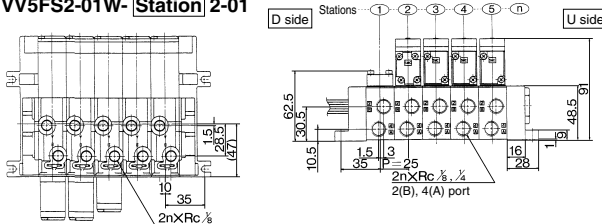

Station	1	2	3	4	5	6	7	8	9	10	11	12	13	14	15	Formula
L <sub>1</sub>	70	95	120	145	170	195	220	245	270	295	320	345	370	395	420	L <sub>1</sub> = 25n + 45
L <sub>2</sub>	81	106	131	156	181	206	231	256	281	306	331	356	381	406	431	L <sub>2</sub> = 25n + 56

<b>SV</b>
<b>SYJ</b>
<b>SZ</b>
<b>VF</b>
<b>VP4</b>
VQ 1/2
VQ 4/5
VQC 1/2
VQC 4/5
<b>VQZ</b>
<b>SQ</b>
<b>VFS</b>
<b>VFR</b>
<b>VQ7</b>

# VFS2000 Series Made to Order

Serial Transmission Kit Manifold: EX123/124 Integrated-type (For Output)  
Serial Transmission System



## How to Order

### How to Order Manifold

VV5FS2 - 01S V - 08 1 - 02 - X460

Plug-in type  
Serial transmission kit

Stations

03	3 stations
:	:
18	18 stations

Note 1) Max. 18 stations. Add 2 stations for serial unit mounting.

Note 2) Max. 18 stations for all-single wiring. (No. of valves: 18)

For the standard double wiring, the maximum number of stations is 10. (No. of valves: 8)

Port size

Symbol	P, R1, R2	A, B
01		1/8
02	1/4	1/4
M		Mixed

\* For bottom ported: 1/8 only

Thread type

NII	Rc
N	NPT
T	NPTF
F	G

Combination symbol

Symbol	Port specification		Piping specification A, B
	P	R1, R2	
1	Common	Common	Side
2*			Bottom
3*	Common	Individual	Side
4*			Bottom
5*	Individual	Common	Side
6*			Bottom
7*	Individual	Individual	Side
8*			Bottom

\* Semi-standard

Compatible with SI unit U side mounting only

Applicable models

Symbol	SI unit part no.	Description
0	—	Without SI unit
H	EX123U-SUH1	NKE Corporation: Fieldbus H System (16 outputs)
Q	EX124U-SDN1	DevieNet (2 power supply systems)
R1	EX124U-SCS1	OMRON Corporation: CompoBus/S (16 outputs) (2 power supply systems)
R2	EX124U-SCS2	OMRON Corporation: CompoBus/S (8 outputs) (2 power supply systems)
V	EX124U-SMJ1	CC-Link (2 power supply systems)

Refer to Best Pneumatics No. 1-1 and the Operation Manual for the details of EX123/124 Integrated-type (For Output) Serial Transmission System. Please download the Operation Manual via our website, <http://www.smcworld.com>

### Correspondence of SI unit output numbers and solenoid valve coils

<Wiring Example 1> Double wiring (Standard)

D side

U side

SI unit output no.	1	2	3	4	5	6	7	8	9	10
	Double	Double	Single	Single	Single	Double	Single	Single	SI unit	
	A B	A B	A B	A B	A B	A B	A B	A B		
01	23	45	67	89	1011	1213	1415			

<Wiring Example 2> Single/Double mixed wiring (Semi-standard)

D side

U side

SI unit output no.	1	2	3	4	5	6	7	8	9	10	11	12
	Double	Double	Single	Single	Single	Double	Single	Double	Single	Single	SI unit	
	A B	A B	A	A	A	A B	A	A B	A	A		
01	23	4	5	6	78	9	1011	11	12			

\* Mixed wiring is available as a semi-standard.  
Use the manifold specification sheet to specify this.

### How to Order Valves

VFS2 - 00 - 5 F -

Symbol

1	2 position single
2	2 position double
3	3 position closed center
4	3 position exhaust center
5	3 position pressure center
6	3 position double check

Pilot valve manual override

NII	Non-locking push type (Flush)
A	Non-locking push type (Extended)
B	Locking type (Tool required)
C	Locking type (Lever)

Option

NII	None
Z	With light/surge voltage suppressor

Coil rated voltage

NII	None
-----	------

24 VDC

**Serial Transmission Kit Manifold: EX123/124 Integrated-type (For Output) Serial Transmission System**

VV5FS2-01S Model - Stations Symbol - Port size -X460

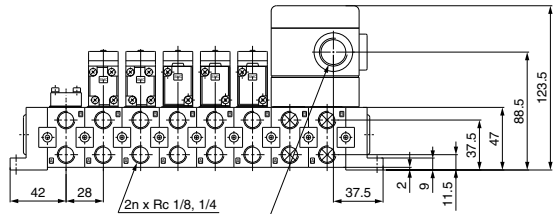
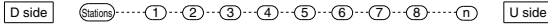
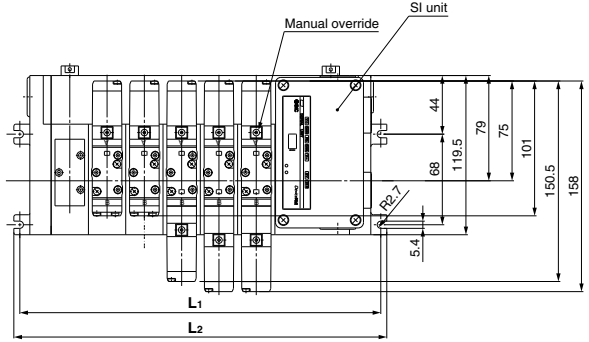
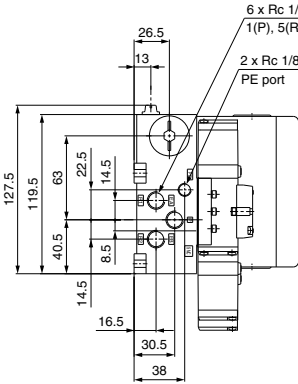

\* Use a dripproof plug assembly (AXT100-B04A) for the unused conduit port (G 1/2).

Formula  $L_1 = 28n + 47$   $L_2 = 28n + 56$   
n: Stations (Max. 18 stations)

**Dimensions**

L	n	3	4	5	6	7	8	9	10	11	12	13	14	15	16	17	18
L <sub>1</sub>		131	159	187	215	243	271	299	327	355	383	411	439	467	495	523	551
L <sub>2</sub>		140	168	196	224	252	280	308	336	364	392	420	448	476	504	532	560

Note) Actual number of manifold base stations: Add 2 SI unit mounting stations to the number of valve stations.

- SV
- SYJ
- SZ
- VF
- VP4
- VQ 1/2
- VQ 4/5
- VQC 1/2
- VQC 4/5
- VQZ
- SQ
- VFS
- VFR
- VQ7

# VFS2000 Series

## Manifold Base Construction — Plug-in type, Non plug-in type

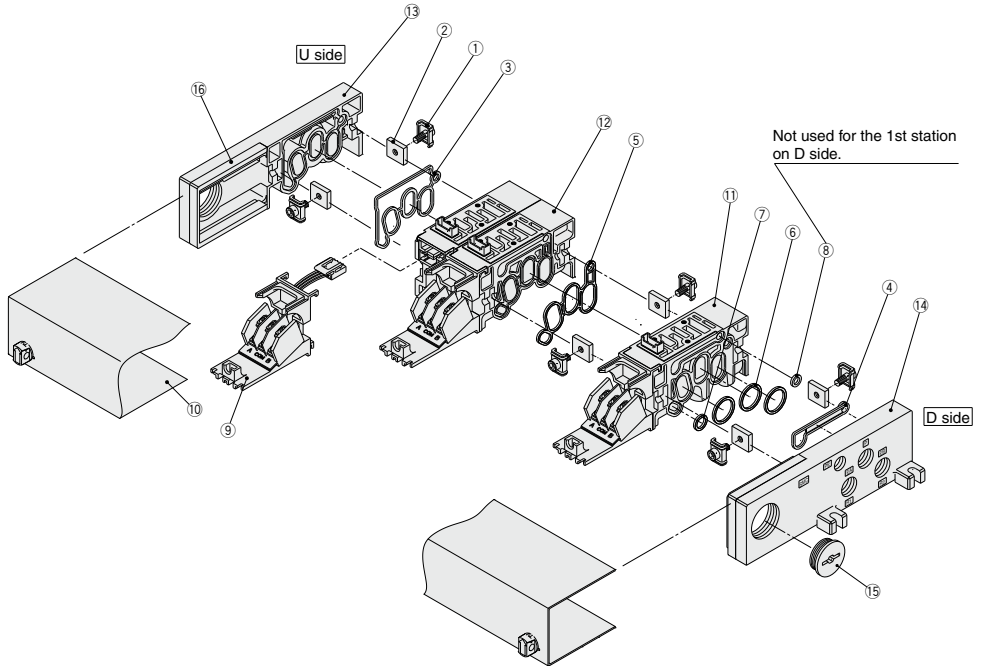

\* Manifold Base/Construction: Plug-in type with terminal block (01T1).

• For increasing the manifold bases, please order the manifold block assembly number of the principle number assembly ① and ⑫.

• For plug-in type: The manifold base with terminal stand (integrated with a junction cover) is required with the ⑬ junction cover assembly.

• Manifold base is consisted of the junction of 2 and 3 station bases.

Example) U side (n) ⑥ ⑤ ④ ③ ② ① D side

<5 stations (Odd number)> 2 stations | 2 stations | 1 station

<6 stations (Even number)> 2 stations | 2 stations | 1 station | 1 station

# 5 Port Pilot Operated Solenoid Valve Metal Seal, Plug-in/Non Plug-in **VFS2000 Series**

## Replacement Parts

No.	Description	Material	Part no.
1	<b>Connection fitting assembly</b>	Steel plate	AXT625-4-1A
2	<b>Connection fitting B</b>	Steel plate	AXT625-5
3	<b>Gasket A</b>	NBR	AXT625-17
4	<b>Gasket B</b>	NBR	AXT625-16
5	<b>Gasket</b>	HNBR	VVFS2000-32-1H
6	<b>O-ring</b>	NBR	KA00292
7	<b>O-ring</b>	NBR	KA00276
8	<b>O-ring</b>	NBR	KA00326
9	<b>Adapter plate</b>	Resin	For 01 AXT625-6
	<b>Adapter plate assembly</b>	—	For 01T AXT625-28-13A For 01T1 (Terminal section with adapter plate and lead wire assembly)
	<b>Adapter plate</b>	Resin	For 01C AXT625-28-1 For 01F VVF2000-26-6 For 01S□ AXT625-6
10	<b>Junction cover assembly</b>	—	For 01 AXT625-7A
			For 01T AXT625-28-3A
			For 01T1 AXT625-28-7A-(Stations)
			For 01C AXT625-28-7A-(Stations)
			For 01F VVF2000-26-5A-(Stations)
For 01S□ AZ738-10A-(Stations)			
15	<b>Rubber plug</b>	NBR	For 01 AXT333-12 For 01T (1) AXT625-22 01S□
	<b>Plug</b>	—	For 01W EXP22S
16	<b>Guard</b>	Resin	For 01T (1) AXT625-28-4

## Replacement Parts: Sub Assembly

No.	Description	Part no.	Component parts	Applicable manifold base
11	<b>Manifold block assembly (for 1 station)</b>	AXT625-01A- $\frac{1}{2}$ (-B) (Note)	Manifold block (1), Metal joint (1), (2), O-ring (6), (7), (8), Junction cover (10), Adapter plate (9), Pin housing, Guide, Insert plug lead wire	Plug-in type With attachment plug lead wire
		AXT625-20A- $\frac{1}{2}$ (-B) (Note)	Manifold block (1), Metal joint (1), (2), O-ring (6), (7), (8), Junction cover (10), Adapter plate assembly (with terminal) (9), Pin housing, Guide	Plug-in type With terminal block
		AXT625-10A- $\frac{1}{2}$ (-B) (Note)	Manifold block (1), Metal joint (1), (2), O-ring (6), (7), (8)	Non plug-in type
12	<b>Manifold block assembly (for 2 stations)</b>	AXT625-01A2- $\frac{1}{2}$ (Note)	Manifold block (12), Metal joint (1), (2), Gasket (5), Junction cover (10), Adapter plate (9), Pin housing, Guide, Insert plug lead wire	Plug-in type With attachment plug lead wire
		AXT625-20A2- $\frac{1}{2}$ (Note)	Manifold block (12), Metal joint (1), (2), Gasket (5), Junction cover (10), Adapter plate assembly (with terminal) (9), Pin housing, Guide	Plug-in type With terminal block
		AXT625-10A2- $\frac{1}{2}$ (Note)	Manifold block (11), Metal joint (1), (2), Gasket (5)	Non plug-in type
13	<b>End plate (U side) assembly</b>	AXT625-2A	End plate (U) (13), Metal joint (1), (2), Gasket A (3), Guard (16)	Plug-in type With attachment plug lead wire
		AXT625-2A-20	End plate (U) (13), Metal joint (1), (2), Gasket A (3), Guard (16)	Plug-in type With terminal block
		AXT625-2A-10	End plate (U) (13), Metal joint (1), (2), Gasket A (3)	Non plug-in type
14	<b>End plate (D side) assembly</b>	AXT625-3A	End plate (D) (14), Metal joint (1), (2), Gasket B (4), Guard (16), Steel ball	Plug-in type With attachment plug lead wire
		AXT625-3A-20	End plate (D) (14), Metal joint (1), (2), Gasket B (4), Guard (16), Steel ball	Plug-in type With terminal block
		AXT625-3A-10	End plate (D) (14), Metal joint (1), (2), Gasket B (4), Steel ball	Non plug-in type

Note) 1: A, B port size Rc 1/8, 2: A, B port size Rc 1/4, (-B): A, B port bottom ported

SV

SYJ

SZ

VF

VP4

VQ

1/2

VQ

4/5

VQC

1/2

VQC

4/5

VQZ

SQ

VFS

VFR

VQ7

## Light Compact Type Sub-plate/C: 2.8 dm<sup>3</sup>/(s-bar)

C: 2.2 dm<sup>3</sup>/(s-bar)

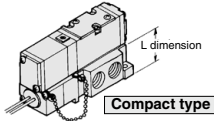

C: 2.8 dm<sup>3</sup>/(s-bar)

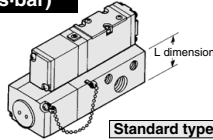

### Sub-plate

Type	L dimension (mm)	Weight (kg)
Compact type	25.5	0.13
Standard type	31	0.2

### Sub-plate — Compact: Plug-in, Grommet (With attachment plug lead wire)

VFS2□00-□F-(B)<sup>P01</sup>/<sub>P02</sub>

Sub-plate assembly part no.: VFS2000-CP-(B)<sup>01</sup>/<sub>02</sub> (01: Rc 1/8, 02: Rc 1/4)

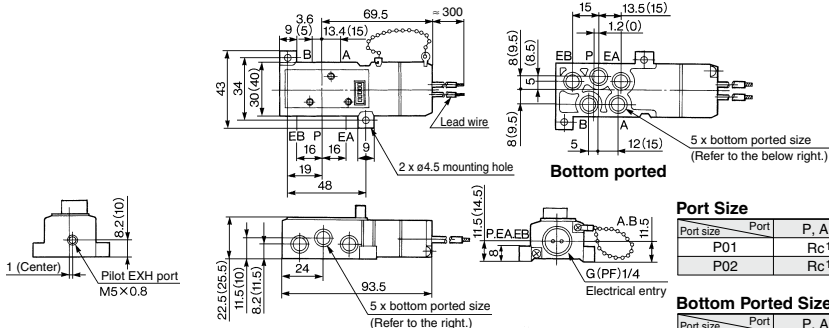

### Port Size

Port size	Port	P, A, B	EA, EB
P01		Rc 1/8	Rc 1/8
P02		Rc 1/4	Rc 1/8

### Bottom Ported Size

Port size	Port	P, A, B	EA, EB
BP02		Rc 1/8, 1/4	Rc 1/8

( ): Port size P02

### Sub-plate — Compact: Non plug-in

VFS2□10-□□-(B)<sup>S01</sup>/<sub>S02</sub>

Sub-plate assembly part no.: VFS2000-CS-(B)<sup>01</sup>/<sub>02</sub> (01: Rc 1/8, 02: Rc 1/4)

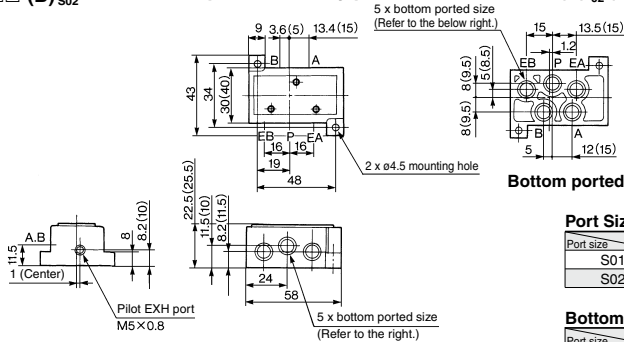

### Port Size

Port size	Port	P, A, B	EA, EB
S01		Rc 1/8	Rc 1/8
S02		Rc 1/4	Rc 1/8

### Bottom Ported Size

Port size	Port	P, A, B	EA, EB
BS02		Rc 1/8, 1/4	Rc 1/8

( ): Port size S02

### Precautions Please pay attention to piping port location of sub-plate.

VFS2□□0-□□<sup>P01/02</sup>: Compact type

VFS2□□0-□□<sup>01/02</sup>: Standard type

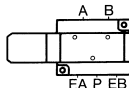
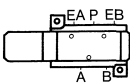

### Electrical Connection

#### Compact type, plug-in type grommet sub-plate (With attachment plug lead wire)

- The attachment plug lead wire is attached to the manifold block and lead wire is plugged in with valve side as shown in the following list. Please connect with corresponding power side.

Lead wire color	Schematic	
	A side	B side
Red	Black	Brown
Black	Brown	White

- There is no polarity.



<b>SV</b>
<b>SYJ</b>
<b>SZ</b>
<b>VF</b>
<b>VP4</b>
VQ 1/2
VQ 4/5
VQC 1/2
VQC 4/5
<b>VQZ</b>
<b>SQ</b>
<b>VFS</b>
<b>VFR</b>
<b>VQ7</b>

# 5 Port Pilot Operated Solenoid Valve Metal Seal, Plug-in/Non Plug-in

## VFS3000 Series



[Option]

NRTL / C

(Details → P. 1005)

### Model

Type of actuation		Model		Port size Rc	Flow rate characteristics						Max. operating cycle (cpm) <sup>(1)</sup>	Response time (ms) <sup>(2)</sup>	Weight (kg) <sup>(3)</sup>
		Plug-in	Non plug-in		1 → 4/2 (P → A/B)			4/2 → 5/3 (A/B → R1/R2)					
					C [dm <sup>3</sup> /(s·bar)]	b	Cv	C [dm <sup>3</sup> /(s·bar)]	b	Cv			
2 position	Single	VFS3100	VFS3110	1/4	6.0	0.15	1.4	5.8	0.12	1.3	1200	20 or less	0.31
				3/8	7.3	0.23	1.8	6.8	0.12	1.6			
	Double	VFS3200	VFS3210	1/4	6.0	0.15	1.4	5.8	0.12	1.3	1500	15 or less	0.41
				3/8	7.3	0.23	1.8	6.8	0.12	1.6			
3 position	Closed center	VFS3300	VFS3310	1/4	5.8	0.21	1.4	5.4	0.14	1.2	600	40 or less	0.43
				3/8	6.8	0.22	1.7	6.3	0.12	1.5			
	Exhaust center	VFS3400	VFS3410	1/4	6.1	0.23	1.4	5.0	0.14	1.2	600	40 or less	0.43
				3/8	7.4	0.20	1.8	5.6	0.18	1.3			
	Pressure center	VFS3500	VFS3510	1/4	6.0	0.22	1.5	5.8	0.16	1.3	600	40 or less	0.43
				3/8	7.2	0.19	1.8	7.1	0.18	1.8			
Double check	VFS3600	VFS3610	1/4	4.0	—	—	3.5	—	—	600	50 or less	0.91	
			3/8	4.0	—	—	3.7	—	—				

Note 1) Based on JIS B 8419: 2010 (once per 30 days) for the minimum operating frequency.

Note 2) Based on JIS B 8419:2010. (The value at supply pressure 0.5 MPa, ambient/fluid temperature (= 20°C))

Note 3) The figures in the above list are for without sub-plate. In the case of with plug-in sub-plate and with non plug-in sub-plate, add 0.30 kg and 0.27 kg respectively.

Note 4) "Note 1)" and "Note 2)" are with controlled clean air.

Compact yet provides a large flow capacity

3/8: C: 5.8 dm<sup>3</sup>/(s·bar)

Low power consumption: 1.8 W DC

Easy maintenance

2 types of sub-plates:

Plug-in and non plug-in

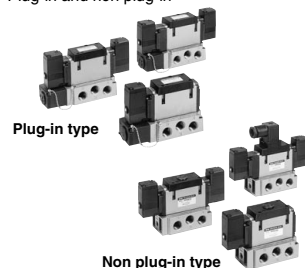

### Symbol

2 position	3 position
Single (A4, 2/B)  5 1 3 (R1/P1/R2)	Closed center (A4, 2/B)  5 1 3 (R1/P1/R2)
Double (A4, 2/B)  5 1 3 (R1/P1/R2)	Exhaust center (A4, 2/B)  5 1 3 (R1/P1/R2)
Pressure center (A4, 2/B)  5 1 3 (R1/P1/R2)	
Double check (A4, 2/B)  5 1 3 (R1/P1/R2)	

### Standard Specifications

Valve specifications	Fluid	Air	
	Maximum operating pressure	1.0 MPa	
	Minimum operating pressure	0.1 MPa	
	Proof pressure	1.5 MPa	
	Ambient and fluid temperature	-10 to 60°C <sup>(1)</sup>	
	Lubrication	Non-lube <sup>(2)</sup>	
	Pilot valve manual override	Non-locking push type (Flush)	
	Impact/Vibration resistance	150/50 mv/s <sup>(2)</sup>	
	Enclosure	Type E: Dustproof (Equivalent to IP50), Type F: Dripproof (Equivalent to IP52), Type D: Splashproof (Equivalent to IP54) <sup>(6)</sup>	
	Electricity specifications	Coil rated voltage	100, 200 VAC, 50/60 Hz, 24 VDC
Allowable voltage fluctuation		-15 to +10% of rated voltage	
Coil insulation type		Class B or equivalent (130°C) <sup>(5)</sup>	
Apparent power (Power consumption) AC		Inrush	5.6 VA/50 Hz, 5.0 VA/60 Hz
		Holding	3.4 VA (2.1 W)/50 Hz, 2.3 VA (1.5 W)/60 Hz
Power consumption DC		1.8 W (2.04 W: With light/surge voltage suppressor)	
Electrical entry		Plug-in type	Conduit terminal
	Non plug-in type	DIN terminal, Grommet terminal	

Note 1) Use dry air at low temperatures.

Note 2) Use turbine oil Class 1 (ISO VG32), if lubricated.

Note 3) Impact resistance: No malfunction occurred when it is tested with a drop tester in the axial direction and at the right angles to the main valve and armature in both energized and de-energized states every once for each condition. (Values at the initial period)

Vibration resistance: No malfunction occurred in a one-sweep test between 45 and 2000 Hz. Test was performed at both energized and de-energized states in the axial direction and at the right angles to the main valve and armature. (Values at the initial period)

Note 4) Based on JIS C 0920.

Note 5) Based on JIS C 4003.

Note 6) The F and D type enclosures described above show those without the light/surge voltage suppressor.

The F and D type enclosures with the light/surge voltage suppressor are equivalent to IP50.

### Option

Pilot type		External pilot <sup>(Note)</sup>
Manual override	Main valve	Direct manual override type
	Pilot valve	
Coil rated voltage		110 to 120, 220, 240 VAC (50/60 Hz) 12, 100 VDC
Porting specifications		Bottom ported
Option		With light/surge voltage suppressor

Note) Operating pressure: 0 to 1.0 MPa

Pilot pressure: 0.1 to 1.0 MPa



How to Order

**Body type**

**O:** Plug-in type sub-plate

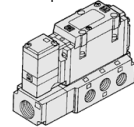

**F:** Plug-in type conduit terminal

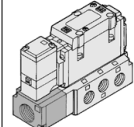

**Porting specifications**

**NII** Side ported  
**B\*** Bottom ported  
\* Semi-standard

**Port size**

NII	Without sub-plate
02	1/4
03	3/8

\* For bottom ported, 1/4 is only available.

**Thread type**

NII	Rc
N*	NPT
T*	NPTF
F*	G

\* Semi-standard

**CE/UKCA-compliant**

NII	—
Q	CE/UKCA-compliant

**Option**

NII	None
Z	With light/surge voltage suppressor

**Electrical entry**

**E:** Grommet terminal  
**D:** DIN terminal  
**DO:** DIN terminal without connector

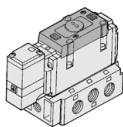
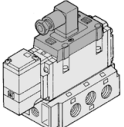
**Coil rated voltage**

1	100 VAC, 50/60 Hz
2	200 VAC, 50/60 Hz
3*	110 to 120 VAC, 50/60 Hz
4*	220 VAC, 50/60 Hz
5	24 VDC
6*	12 VDC
7*	240 VAC, 50/60 Hz

\* Semi-standard  
For other rated voltages, please consult with SMC.

**Pilot type**

NII	Internal pilot
R*	External pilot

\* Semi-standard

**Manual override**

**NII:** Non-locking push type (Flush)



**A\*:** Non-locking push type (Extended)



**B\*:** Locking type (Tool required)



**C\*:** Locking type (Lever)



\* Semi-standard

**Plug-in** VFS3 1 0 0 - 1 F - - - 02 - - -

**Non plug-in** VFS3 2 1 1 - 2 D - - - 02 - - -

**Symbol**

1	2 position single (A)4 2(B) 5 1 3 (R1)(P)(R2)	5	3 position pressure center (A)4 2(B) 5 1 3 (R1)(P)(R2)
2	2 position double (A)4 2(B) 5 1 3 (R1)(P)(R2)	6	3 position double check (A)4 2(B) 5 1 3 (R1)(P)(R2)
3	3 position closed center (A)4 2(B) 5 1 3 (R1)(P)(R2)		
4	3 position exhaust center (A)4 2(B) 5 1 3 (R1)(P)(R2)		

\* Reverse pressure: Can be used by external pilot specifications.

SV
SYJ
SZ
VF
VP4
VQ 1/2
VQ 4/5
VQC 1/2
VQC 4/5
VQZ
SQ
VFS
VFR
VQ7

How to Order Pilot Valve Assembly

SF4 - 1 F - 30

**Coil rated voltage**

Symbol	Rated voltage
1	100 VAC, 50/60 Hz
2	200 VAC, 50/60 Hz
3*	110 to 120 VAC, 50/60 Hz
4*	220 VAC, 50/60 Hz
5	24 VDC
6*	12 VDC
7*	240 VAC, 50/60 Hz

\* Semi-standard  
For other rated voltages, please consult with SMC.  
\*\* Refer to page T010 for voltage conversion.

**Manual override**

Symbol	Manual override
NII	Non-locking push type (Flush)
A*	Non-locking push type (Extended)
B*	Locking type (Tool required)
C*	Locking type (Lever)

\* Semi-standard



# VFS3000 Series

## Cylinder Speed Chart

Use as a guide for selection.  
Please confirm the actual conditions with SMC Sizing Program.

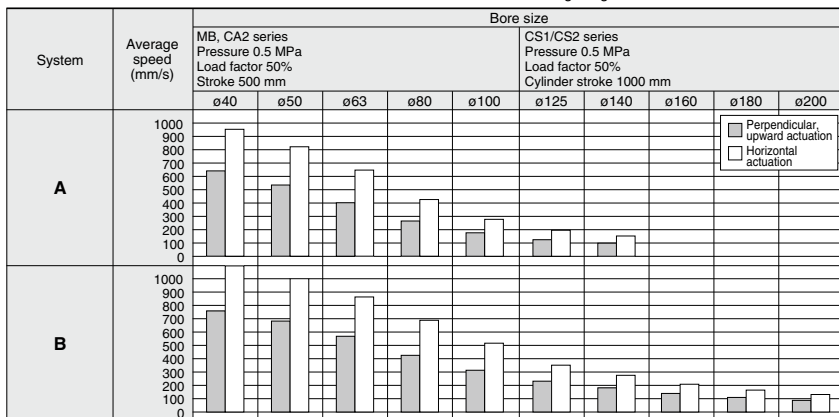

### System Components

System	Solenoid valve	Speed controller	Silencer	SGP (Steel pipe) Port size x Length
A	VFS3000 Series Rc <sup>1</sup> / <sub>4</sub>	AS4000-02 (S = 24 mm <sup>2</sup> )	AN20-02 (S = 35 mm <sup>2</sup> )	6A x 1 m
B	VFS3000 Series Rc <sup>3</sup> / <sub>8</sub>	AS420-03 (S = 73 mm <sup>2</sup> )	AN30-03 (S = 60 mm <sup>2</sup> )	10A x 1 m

- \* It is when the cylinder is extending that is meter-out controlled by speed controller which is directly connected with cylinder, and its needle valve with being fully open.
- \* The average velocity of the cylinder is the value that the stroke is divided by the total stroke time.
- \* Load factor: ((Load mass x 9.8)/Theoretical force) x 100%

## Double Check Spacer/Specifications

### Can hold an intermediate cylinder position for an extended time

If the double check spacer with a built-in double check valve is combined, it will enable the cylinder to stop in the intermediate stroke and maintain its position for a long time without being affected by the leakage between the spools.

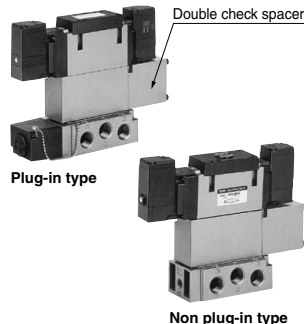

### Specifications

Double check spacer part no.	Plug-in type	Non plug-in type
	VVFS3000-22A-1	VVFS3000-22A-2
Applicable valve model	VFS3400-□F	VFS3410-□D VFS3410-□E

### ⚠ Caution

- In the case of 3 position double check valve (VFS36□0), check the leakage from piping and fittings in between valve and cylinder by means of synthetic detergent solutions, and ensure that there is no such leakage found there. Also check the leakage from cylinder seal and piston seal. If there is any leakage, sometimes the cylinder, when valve is de-energized, can move without stopping at intermediate position.
- Be aware that if the exhaust side is restricted stopping accuracy will decrease and will lead to improper intermediate stops.

### Check Valve Operation

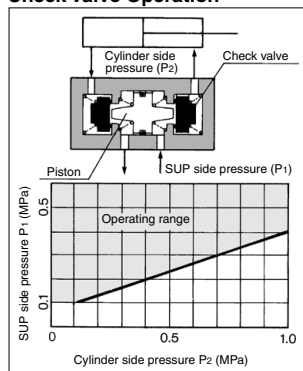

- The combination of VFS31<sup>1</sup>0, VFS32<sup>2</sup>0 and double check spacer can be used as prevention for falling at the stroke end but cannot hold the intermediate position of the cylinder.

**Construction**

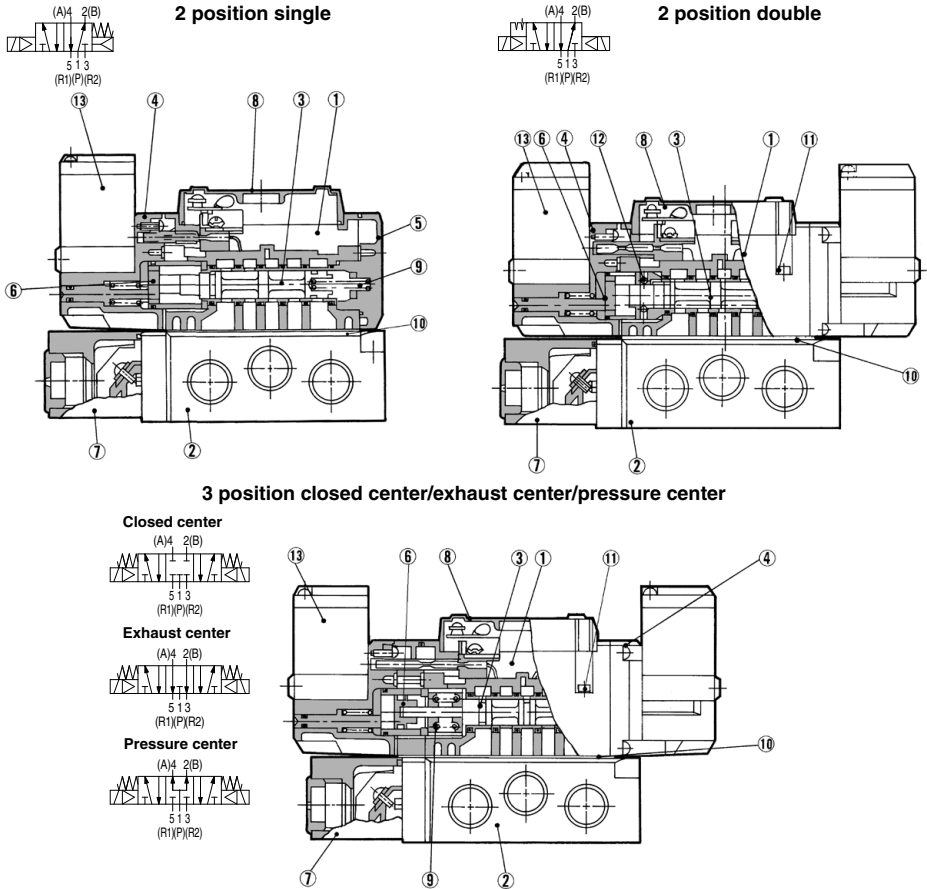

SV
SYJ
SZ
VF
VP4
VQ 1/2
VQ 4/5
VQC 1/2
VQC 4/5
VQZ
SQ
VFS
VFR
VQ7

**Component Parts**

No.	Description	Material	Note
1	Body	Aluminum die-casted	—
2	Sub-plate	Aluminum die-casted	—
3	Spool/Sleeve	Stainless steel	—
4	Adapter plate	Resin	—
5	End plate	Resin	—
6	Piston	Resin	—
7	Junction cover	Resin	—
8	Light cover	Resin	—
9	Return spring	Stainless steel	—
10	Gasket	HNBR	—
11	Hexagon socket head screw	Steel	—
12	Detent assembly	—	—
13	Pilot valve assembly	—	—

\* Refer to "How to Order Pilot Valve Assembly" on page 941.

**Sub-plate Assembly Part No.**

Plug-in	VFS3000-P-R <sup>02</sup> <sub>08</sub> (N, T, F)
Non plug-in	VFS3000-S-R <sup>02</sup> <sub>08</sub> (N, T, F)

\* Mounting bolt and gasket are not included.

**Sub-plate Assembly (For External Pilot) Part No.**

Plug-in	VFS3000-P-R <sup>02</sup> <sub>08</sub> (N, T, F)
Non plug-in	VFS3000-S-R <sup>02</sup> <sub>08</sub> (N, T, F)

Part no. for mounting bolt and gasket	Note
BG-VFS3000	Plate gasket type (Earlier than September, 2012) <sup>Note</sup>
BG-VFS3000-1	Groove gasket type (After October 2012) <sup>Note</sup>

Note) When ordering the parts shown above for the replacement, note that the described date may slightly vary depending on the product being used.

# VFS3000 Series

## Plug-in — 2 Position single/3 Position closed center/Exhaust center/Pressure center/Double check

### 2 position single: VFS3100-□F(Z)

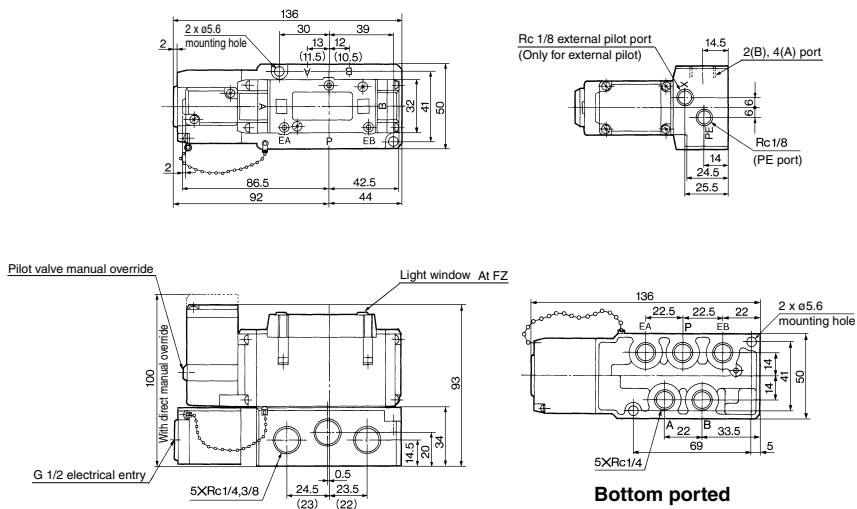

( ): Rc 1/4

### 2 position double: VFS3200-□F(Z)

### 3 position closed center: VFS3300-□F(Z)

### 3 position exhaust center: VFS3400-□F(Z)

### 3 position pressure center: VFS3500-□F(Z)

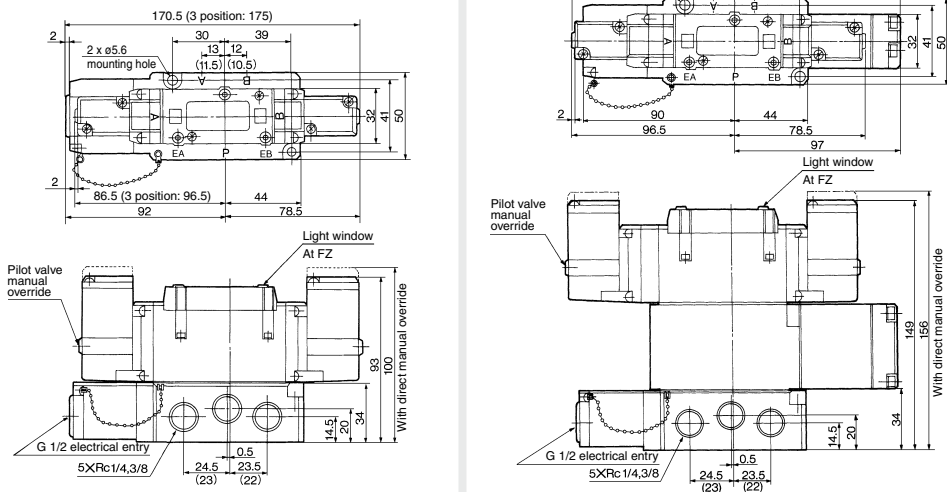

( ): Rc 1/4

( ): Rc 1/4

**Non Plug-in — 2 Position single/Double/3 Position closed center/Exhaust center/Pressure center/Double check**

**2 position single: VFS3110-□E(Z), VFS3110-□D(Z)**

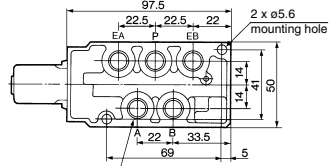
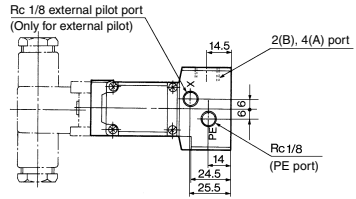
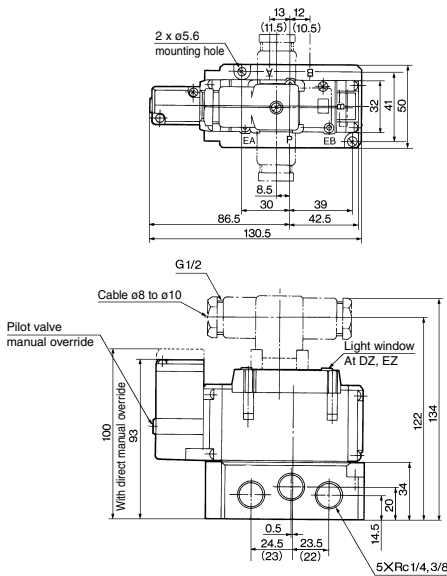

**Bottom ported**

( ): Rc 1/4

**DIN Connector/Gasket Part No.**

Description	No.
Connector	UKL-S1
Gasket	DXT087-27-2

- 2 position double: VFS3210-□E(Z), VFS3210-□D(Z)
- 3 position closed center: VFS3310-□E(Z), VFS3310-□D(Z)
- 3 position exhaust center: VFS3410-□E(Z), VFS3410-□D(Z)
- 3 position pressure center: VFS3510-□E(Z), VFS3510-□D(Z)

**3 position double check: VFS3610-□E(Z), VFS3610-□D(Z)**

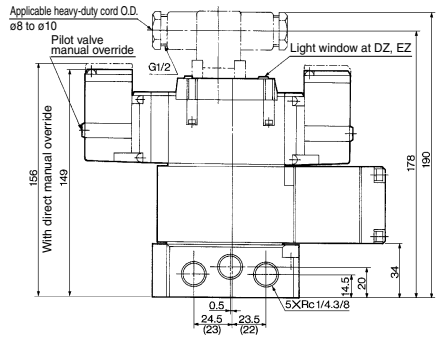
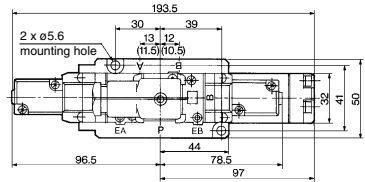
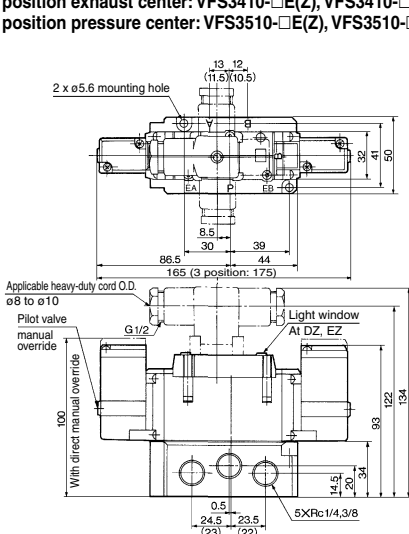

( ): Rc 1/4

( ): Rc 1/4

SV
SYJ
SZ
VF
VP4
VQ 1/2
VQ 4/5
VQC 1/2
VQC 4/5
VQZ
SQ
VFS
VFR
VQ7

# VFS3000 Series Manifold Specifications



## Plug-in Type: With Terminal Block

- Since lead wires of solenoid valve are connected with the terminals on upper surface of terminal block, corresponding lead wires from power source can be wired at the bottom of terminal block.

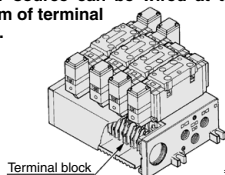

\* Semi-standard

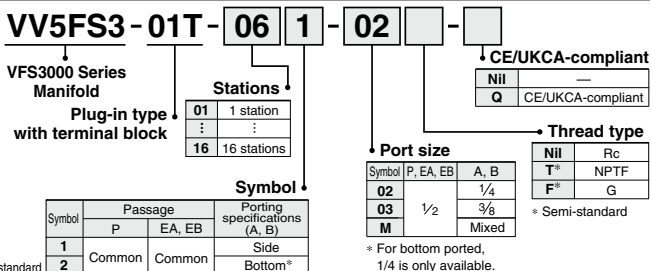

## Plug-in Type: With Multi-connector (Wiring specifications: Refer to page 1013.)

- Quick wiring permits easier installation.

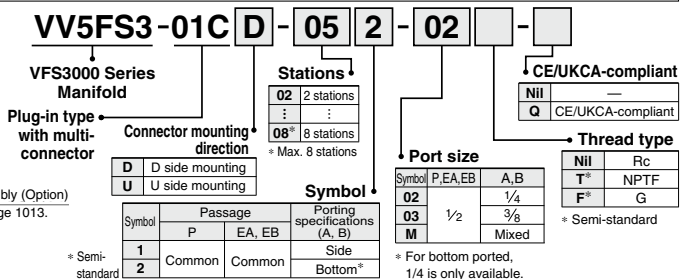
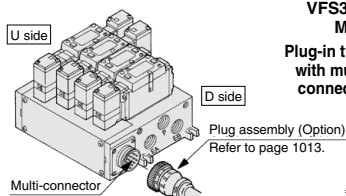

## Plug-in Type: With D-sub Connector (Wiring specifications: Refer to page 1013.)

- Wide range of interchangeability (MIL Spec D-sub connector terminal 25 pcs attached.)
- Quick wiring permits easier installation.

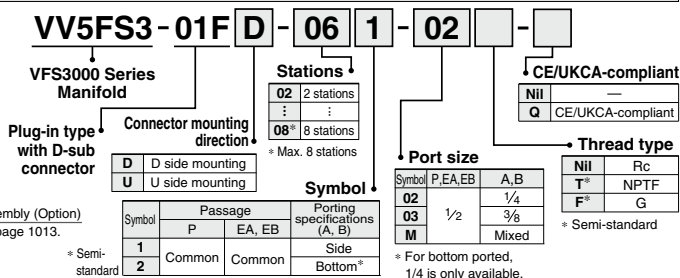
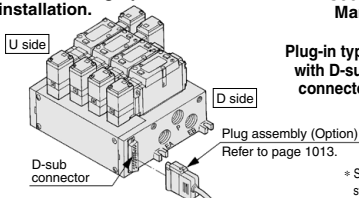

## Non Plug-in Type: Grommet Terminal, DIN Terminal

- Wiring for every valve.

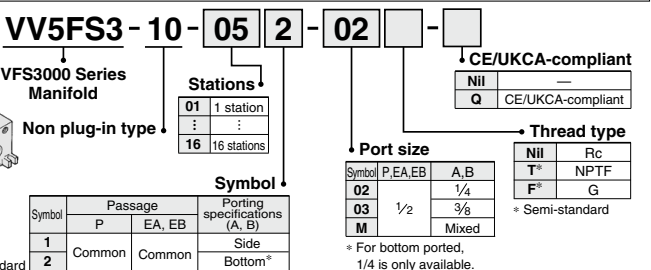
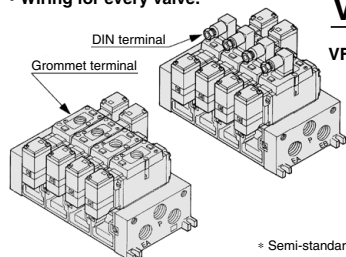



# 5 Port Pilot Operated Solenoid Valve Metal Seal, Plug-in/Non Plug-in **VFS3000 Series**

## How to Order Manifold Assembly

Please indicate manifold base type, corresponding valve, and option parts.

### <Example>

- Plug-in type with terminal block: 6 stations  
(Manifold base) **VV5F53-01T-061-02** .....1  
(2 position single) **VFS3100-5FZ** .....3  
(2 position double) **VFS3200-5FZ** .....2  
(Blanking plate) **VVFS3000-10A** .....1

### <Example>

- Non plug-in type: 6 stations  
(Manifold base) **VV5F53-10-061-03** .....1  
(2 position single) **VFS3110-5D** .....5  
(3 position exhaust center) **VFS3410-5D** .....1  
(Individual EXH spacer) **VVFS3000-R-03-2** ...1

## Manifold Specifications

Base model	Wiring	Porting specifications		Port size Rc		Stations	External pilot	Applicable <sup>(3)</sup> valve model
		A, B port	P	EA, EB	A, B			
Plug-in type <b>VV5F53-01</b> □	<ul style="list-style-type: none"> <li>• With terminal block</li> <li>• With multi-connector</li> <li>• With D-sub connector</li> </ul>	Side/ Bottom	1/2 <sup>(1)</sup>	1/4, 3/8	1 to 16 <sup>(2)</sup>	Yes <sup>(3)</sup>	VFS3□□□(R)□□(Z)	
Non plug-in type <b>VV5F53-10</b>	<ul style="list-style-type: none"> <li>• DIN terminal</li> <li>• Grommet terminal</li> </ul>						VFS3□□□(R)□□(Z) VFS3□□□(R)□□(E)Z	

Note 1) Appropriate silencer for EA, EB port: "AN40-04".

Note 2) With multi-connector, or with D-sub connector: 8 stations max.

Note 3) It is possible to mount the standard valve and the external pilot type valve together.

## Flow Rate Characteristics at the Number of Manifold Stations (Operated individually)

Model	Passage/Stations	Station 1	Station 5	Station 10	
VV5F53	1 → 4/2 (P → A/B)	C [dm <sup>3</sup> /(s·bar)]	6.0	6.0	6.0
		b	0.20	0.20	0.20
		Cv	1.4	1.4	1.4
	4/2 → 5/3 (A/B → R1/R2)	C [dm <sup>3</sup> /(s·bar)]	7.0	7.0	7.0
		b	0.20	0.20	0.20
		Cv	1.8	1.8	1.8

\* Port size: Rc 3/8

- SV**
- SYJ**
- SZ**
- VF**
- VP4**
- VQ 1/2**
- VQ 4/5**
- VQC 1/2**
- VQC 4/5**
- VQZ**
- SQ**
- VFS**
- VFR**
- VQ7**

## Manifold Option Parts Assembly

### Individual SUP spacer

An individual SUP spacer set on manifold block can form SUP port for every valve.

Body type	Plug-in type	Non plug-in type
Part no.	VVFS3000-P-03-1	VVFS3000-P-03-2

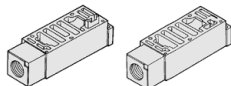

### Individual EXH spacer

An individual EXH spacer set on manifold block can form EXH port for every valve. (common EXH type)

Body type	Plug-in type	Non plug-in type
Part no.	VVFS3000-R-03-1	VVFS3000-R-03-2

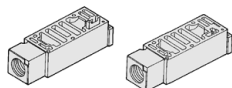

### \* SUP block plate

When supplying manifold with more than two different pressures, high and low, insert a block plate in between stations subjected to different pressures.

Body type	Plug-in type	Non plug-in type
Part no.	AXT636-1A	

### \* EXH block plate

When valve exhaust affects the other stations on the circuit or when the reverse pressure valve is used to standard manifold valve, insert EXH block plate between stations to separate valve exhaust.

Body type	Plug-in type	Non plug-in type
Part no.	AXT636-1A	



When mounting on the 2 stations integrated type manifold block, mount it after cutting the gasket.

### Throttle valve spacer

Needle valve set on the manifold block can control cylinder speed by throttling exhaust.

Body type	Plug-in type	Non plug-in type
Part no.	VVFS3000-20A-1	VVFS3000-20A-2

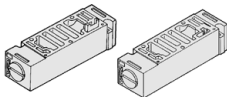

### Double check spacer

If the double check spacer with a built-in double check valve is combined, it will enable the cylinder to stop in the intermediate stroke and maintain its position for a long time without being affected by the leakage between the spools.

Body type	Plug-in type	Non plug-in type
Part no.	VVFS3000-22A-1	VVFS3000-22A-2

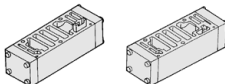

### Interface regulator

Interface regulator set on manifold block can regulate the pressure to each valve. (Refer to page 1011 for "Flow Rate Characteristics".)

Body type	Plug-in type	Non plug-in type
P port regulation	ARBF3050-00-P-1	ARBF3050-00-P-2
A port regulation	ARBF3050-00-A-1	ARBF3050-00-A-2
B port regulation	ARBF3050-00-B-1	ARBF3050-00-B-2

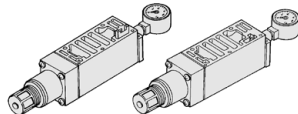

### Blanking plate

It is used by attaching on the manifold block for being prepared for removing a valve for maintenance reasons or planning to mount a spare valve, etc.

Body type	Plug-in type	Non plug-in type
Part no.	VVFS3000-10A	

## Manifold Option

### With exhaust cleaner

#### Plug-in type/Non Plug-in type

- Valve exhaust noise dampening: 35 dB or more.
- Oil mist collection: Rate of collection 99.9% or more.
- Piping process reduced.

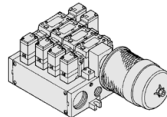

For details, refer to page 951.

### With control unit

#### Plug-in type/Non Plug-in type

- Filter, regulation valve, pressure switch and air release valve are all combined to form one unit.
- Piping processes are eliminated.

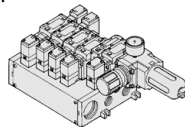

For details, refer to page 952.

### Made to Order

#### Serial transmission kit manifold

#### Plug-in type

- Solenoid valve wiring process reduced considerably.

For details, refer to page 956.

# 5 Port Pilot Operated Solenoid Valve Metal Seal, Plug-in/Non Plug-in **VFS3000 Series**

## Manifold — Plug-in type, Non plug-in type

**Plug-in type (With terminal block): VV5FS3-01T-Station 1-Port size**

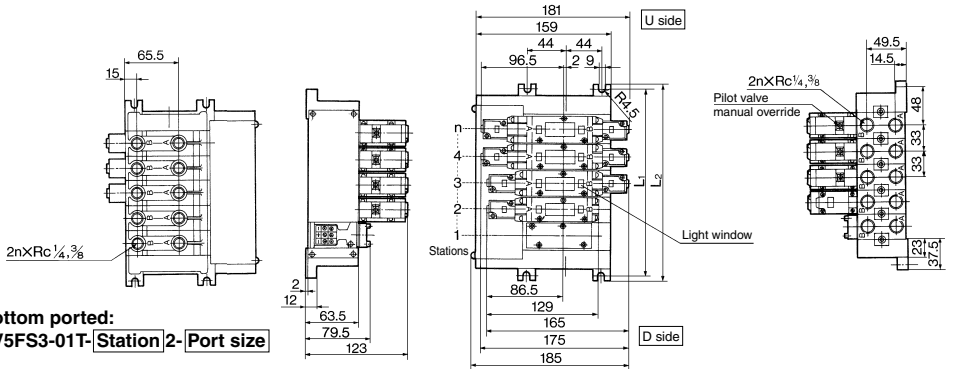

**Bottom ported:  
VV5FS3-01T-Station 2-Port size**

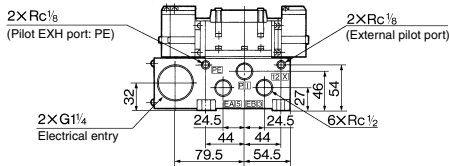

Formula for manifold weight  $M = 0.405n + 0.665$  (kg) n: Station

**Non plug-in type: VV5FS3-10-Station 1-Port size**

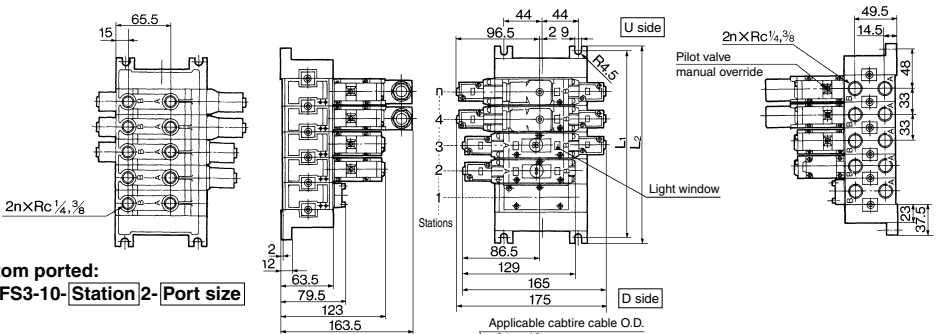

**Bottom ported:  
VV5FS3-10-Station 2-Port size**

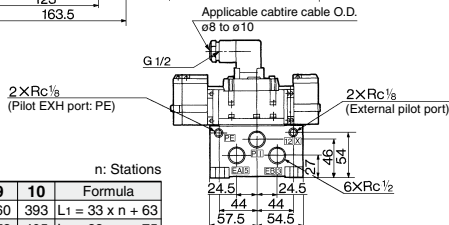

Formula for manifold weight  $M = 0.309n + 0.532$  (kg)

n: Stations

L (Station)	2	3	4	5	6	7	8	9	10	Formula
L <sub>1</sub>	129	162	195	228	261	294	327	360	393	L <sub>1</sub> = 33 x n + 63
L <sub>2</sub>	141	174	207	240	273	306	339	372	405	L <sub>2</sub> = 33 x n + 75

- SV
- SYJ
- SZ
- VF
- VP4
- VQ 1/2
- VQ 4/5
- VQC 1/2
- VQC 4/5
- VQZ
- SQ
- VFS
- VFR
- VQ7

# VFS3000 Series

## Manifold — Plug-in type with multi-connector/D-sub connector

Plug-in type with multi-connector: VV5FS3-01CD-Station 1-Port size, VV5FS3-01CU-Station 1-Port size

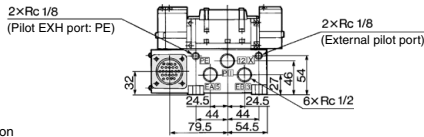
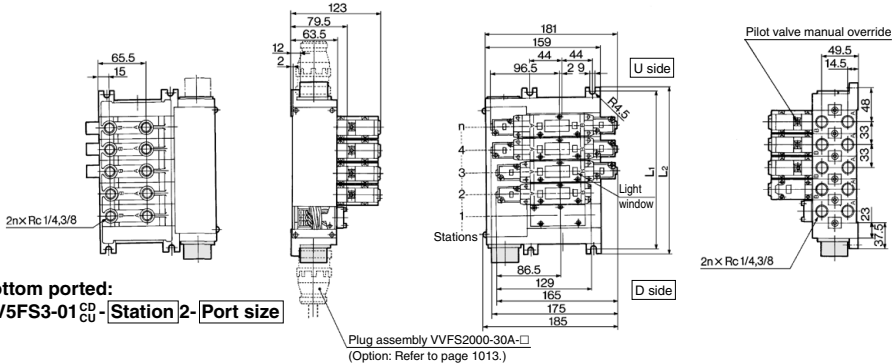

Formula for manifold weight  $M = 0.41n + 0.753$  (kg) n: Station  
 \* Wiring specifications: Refer to page 1013.

Plug-in type with D-sub connector: VV5FS3-01FD-Station 1-Port size, VV5FS3-01FU-Station 1-Port size

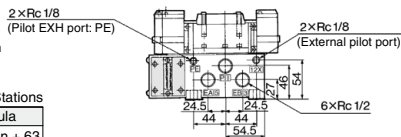
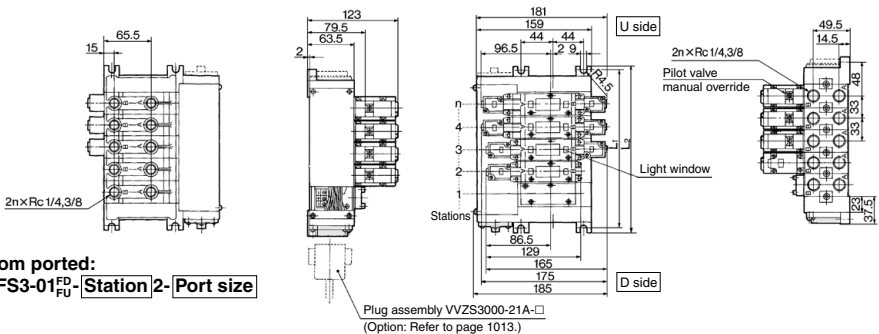

Formula for manifold weight  $M = 0.41n + 0.677$  (kg) n: Station  
 \* Wiring specifications: Refer to page 1013.

		n: Stations							
L	Station	2	3	4	5	6	7	8	Formula
L <sub>1</sub>		129	162	195	228	261	294	327	$L_1 = 33 \times n + 63$
L <sub>2</sub>		141	174	207	240	273	306	339	$L_2 = 33 \times n + 75$

## Manifold with Exhaust Cleaner

- Serves to protect working environment.
- Valve exhaust noise dampening: 35 dB or more.
- Collection rate of drainage and oil mist: 99.9% or more.
- Piping work is reduced.

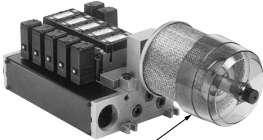

Plug-in type

Exhaust cleaner AMC610-10 (Option)

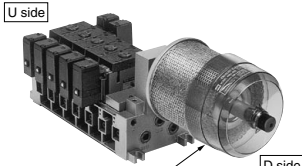

Non plug-in type

Exhaust cleaner AMC610-10 (Option)

### Manifold Specifications

Manifold	Plug-in type: VV5FS3-0□	Non plug-in type: VV5FS3-10
Wiring	With terminal blocks With multi-connector With D-sub connector	DIN terminal Grommet terminal
Applicable valve model	VFS□□00-□F VFS□□10-□D, VFS□□10-□E	
Porting specifications Rc	Common SUP, Common EXH	
	2(B), 4(A) port	1/4, 3/8
Stations	1(P), 3(R2), 5(R1) port	P: 1/2, EXH: 1
Applicable exhaust cleaners	2 to 10 <sup>(1)</sup> AMC610-10 (Connecting port size R 1) <sup>(2)</sup>	

Note 1) With multi-connector, or with D-sub connector: 8 stations max.  
Note 2) Exhaust cleaner "AMC610-10" is not attached.



### How to Order

**VV5FS3 - 10 - 06 1 - 03 - CD -**

**VFS3000 Series Manifold**

**Base type/Electrical entry**

01T	Plug-in type with terminal block
01C	Plug-in type with multi-connector
01F	Plug-in type with D-sub connector
10	Non plug-in type

**Connector mounting direction**

Symbol	With connector	Applicable base
Nil	None	01T, 10
D	D side mounting	01C, 01F
U	U side mounting	

**Stations**

02	2 stations
10	10 stations

Base type 01T, 10: 2-10 stations  
Base type 01C, 01F: 2-8 stations

**CE/UKCA-compliant**

Nil	—
Q	CE/UKCA-compliant

**Exhaust cleaner mounting direction**

Symbol	Exhaust cleaner mounting direction
CD	D side D side mounting
CU	U side U side mounting

**Thread type**

Nil	Rc
T*	NPTF
F*	G

\* Semi-standard

**Port size**

Symbol	P	A, B
02	1/4	
03	1/2	3/8
M		Mixed

\* For bottom ported, 1/4 is only available.

**Symbol**

Symbol	Passage		Porting specifications (A, B)
	P	R1, R2	
1	Common	Common	Side
2			Bottom*

\* Semi-standard

- SV
- SYJ
- SZ
- VF
- VP4
- VQ 1/2
- VQ 4/5
- VQC 1/2
- VQC 4/5
- VQZ
- SQ
- VFS
- VFR
- VQ7

### ⚠ Caution

When using an exhaust cleaner, mount it downwards.

\* For details about exhaust cleaners, refer to Best Pneumatic No. 7.

### How to Order Manifold Assembly [Example]

Add the valve and option part numbers in order starting from the first station on the D side.

#### <Example>

- Plug-in type with terminal block (6 stations)
  - (Manifold base) VV5FS3-01T-061-03-CD ..... 1
  - (2 position single) \* VFS3100-5FZ ..... 3
  - (2 position double) \* VFS3200-5FZ ..... 2
  - (Blanking plate) \* VVFS3000-10A ..... 1
  - (Exhaust cleaner) AMC610-10 ..... 1
- Non plug-in type (6 stations)
  - (Manifold base) VV5FS3-10-061-03-CU ..... 1
  - (2 position single) \* VFS3110-5E ..... 3
  - (2 position double) \* VFS3210-5E ..... 2
  - (Blanking plate) \* VVFS3000-10A ..... 1
  - (Exhaust cleaner) AMC610-10 ..... 1

The asterisk denotes the symbol for assembly. Prefix it to the part numbers of the solenoid valve.

# VFS3000 Series

## Manifold with Exhaust Cleaner — Plug-in type, Non plug-in type

Plug-in type: VV5FS3-01T-Station 1-Port size -<sup>CD</sup>/<sub>CU</sub>

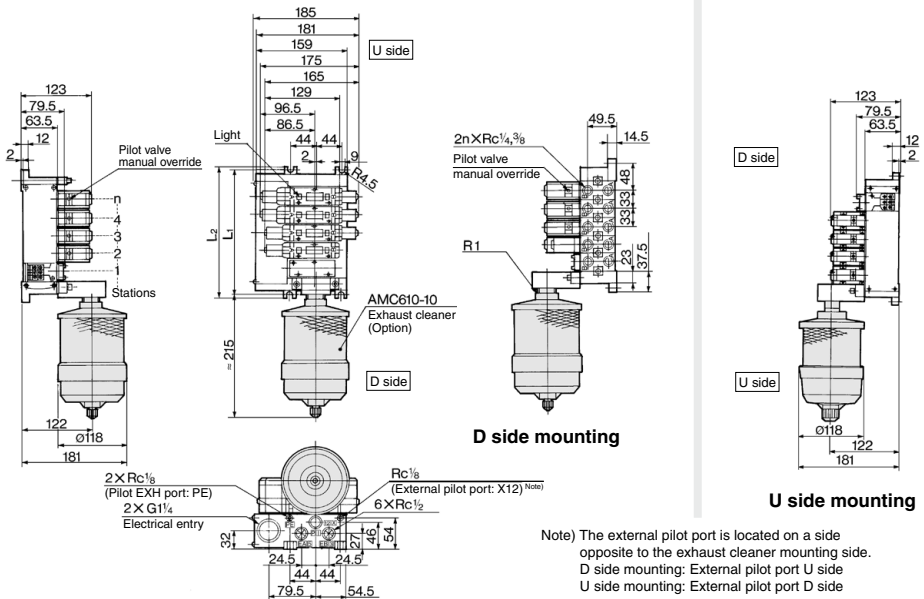

Non plug-in type: VV5FS3-10-Station 1-Port size -<sup>CD</sup>/<sub>CU</sub>

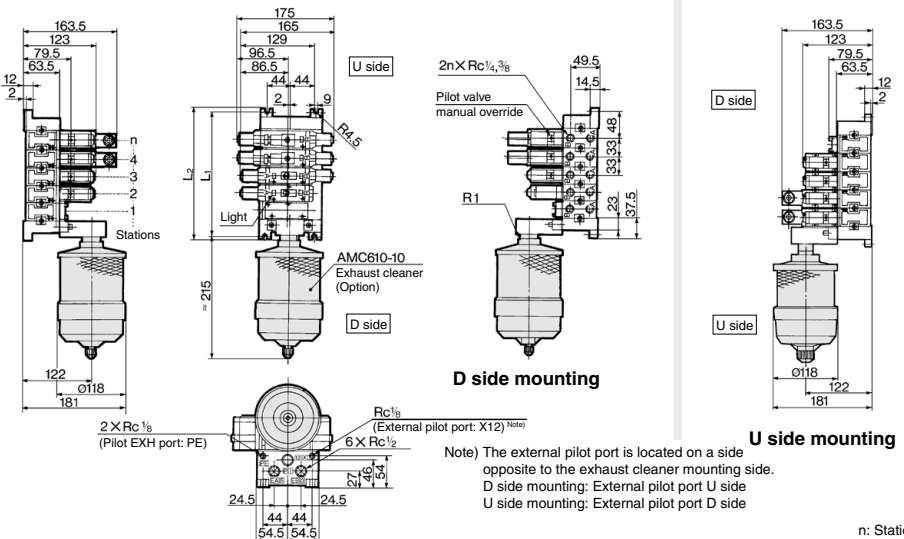

n: Stations

Station	2	3	4	5	6	7	8	9	10	Formula
L <sub>1</sub>	129	162	195	228	261	294	327	360	393	L <sub>1</sub> = 33 x n + 63
L <sub>2</sub>	141	174	207	240	273	306	339	372	405	L <sub>2</sub> = 33 x n + 75

# Manifold with Control Unit

- Control unit (Filter, Regulator, Pressure switch, Air release valve) are all standardized to the one unit, and can be mounted on the manifold base without any attachments.
- Piping processes are eliminated.

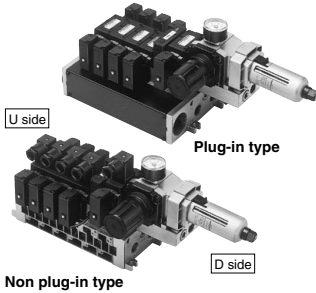

Non plug-in type

### Caution

When using an air filter with auto-drain or manual drain, mount the filter vertically.

### Manifold Specifications

Manifold	Plug-in type: VV5FS3-01□	Non plug-in type: VV5FS3-10
Wiring	With terminal block With multi-connector With D-sub connector	DIN terminal Grommet terminal
Applicable valve model	VFS3□□00-□□	VFS3□□10-□□D, VFS3□□10-□□E
Porting specifications	Common SUP, Common EXH	
	2(B), 4(A) port 1(F), 3(R2), 5(R1) port	1/4, 3/8 1/2
Stations	2 to 10 *	

\* With multi-connector, or with D-sub connector: 8 stations max.

### Control Unit Specifications

Air filter (With auto-drain/With manual drain)	
Filteration degree	5 μm
Regulator	
Set pressure (Outlet pressure)	0.05 to 0.85 MPa
Pressure switch <sup>(1)</sup>	
Set pressure range: OFF	0.1 to 0.6 MPa
Differential	0.08 MPa or less
Contact	1a
Indicator light	LED (RED)
Max. switch capacity	2 VA AC, 2 W DC
Max. operating current	24 VAC/DC or less: 50 mA 100 VAC/DC: 20 mA
Air release valve (Single only)	
Operating pressure range	0.1 to 1.0 MPa

### Control Unit/Option

Air release valve spacer <sup>(2)</sup>	<Plug-in type>	VVFS3000-24A-1R (D side mounting)
	<Non plug-in type>	VVFS3000-24A-2R (D side mounting)
Pressure switch <sup>(3)</sup>	IS1000P-2-1	
Blanking plate	Filter regulator	MP2-3
	Pressure switch	MP3-2
Filter element	Release valve	VVFS3000-24A-10
		INA-13-854-12-5B
Regulator with filter	Manually operated	INA-13-854G
	Auto-drain type	INA-13-854DG

Note 1) Voltage: 24 VDC to 100 VAC

Inner voltage drop: 4 V

Note 2) Combination of valve VFS3□□ (single) and a release valve spacer can be used an air release valve.

Note 3) The non plug-in type cannot be mounted afterwards.



### How to Order

**VV5FS3 - 10 - 08 1 - 02 - AP -**

**VFS3000 Series Manifold Base type/Electrical entry**

01T	Plug-in type with terminal block
01C	Plug-in type with multi-connector
01F	Plug-in type with D-sub connector
10	Non plug-in type

**Connector mounting direction**

Symbol	With connector	Applicable base
NII	None	01T, 10
D	D side mounting	01C, 01F
U	U side mounting	

**Stations**

02	2 stations
:	:
10	10 stations

Base type 01T, 10: 2 to 10 stations  
Base type 01C, 01F: 2 to 8 stations

**Symbol**

Symbol	Passage		Porting specifications (A, B)
	P	EA, EB	
1	Common	Common	Side
2			Bottom*

\* Semi-standard

**Port size**

Symbol	P, EA, EB	A, B
02		1/4
03	1/2	3/8
M		Mixed

\* For bottom ported, 1/4 is only available.

**Thread type**

NII	Rc
T <sup>†</sup>	NPTF
F <sup>‡</sup>	G

\* Semi-standard

**Air release valve coil rating**

NII	None (F, G type only)
1	100 VAC, 50/60 Hz
5	24 VDC

For other rated voltages, please consult with SMC.

**Control unit type**

Symbol	NII	A	AP	M	MP	F	G	C	E
Control equipment									
Air filter with auto-drain	●	●				●			
Air filter with manual drain			●	●		●			
Regulator		●	●	●	●	●			
Air release valve	●	●	●	●	●		●	●	
Pressure switch			●	●					
Blanking plate (Air release valve)						●	●		
Blanking plate (Filter, Regulator)						●	●	●	
Blanking plate (Pressure switch)	●		●			●	●		
Number of manifold blocks required for mounting (stations)	2	2	2	2	2	2	2	1	

### How to Order Manifold Assembly [Example]

Add the valve and option part numbers in order starting from the first station on the D side.

#### <Example>

- Plug-in type with terminal block — In order to mount control unit, it requires 2 stations.
  - (Manifold base) VV5FS3-01T-081-03-AP5 ..... 1
  - (2 position single) \* VFS3100-5FZ ..... 2
  - (2 position double) \* VFS3200-5FZ ..... 4
- Non plug-in type — In order to mount control unit, it requires 2 stations.
  - (Manifold base) VV5FS3-10-061-03-A ..... 1
  - (2 position single) \* VFS3110-5D ..... 4

The asterisk denotes the symbol for assembly. Prefix it to the part numbers of the solenoid valve.

# VFS3000 Series

## Manifold with Control unit — Plug-in type, Non plug-in type

Plug-in type: VVFS3-01T-Station 1-Port size-AP Voltage for release valve

### Example for manifold

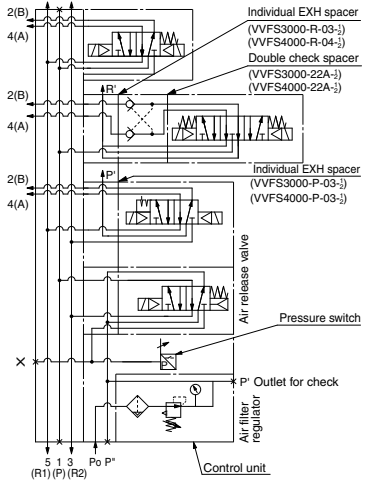
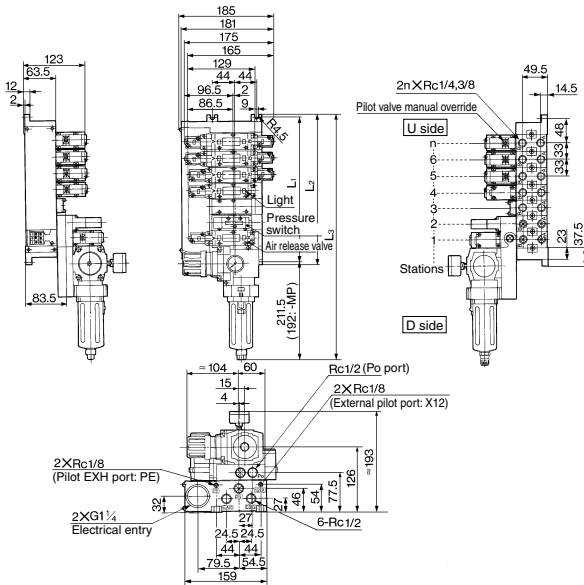

Non plug-in type: VVFS3-10-Station 1-Port size-AP Voltage for release valve

### Example for manifold

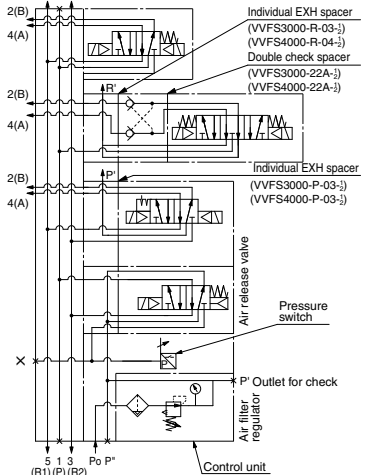
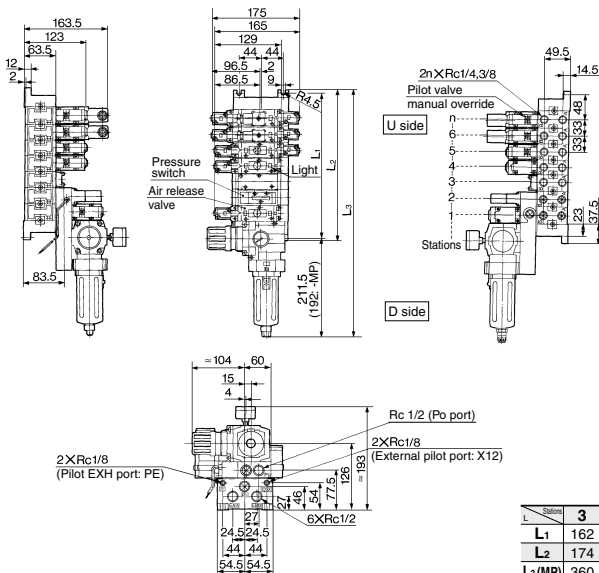

Station	3	4	5	6	7	8	9	10	Formula
L1	162	195	228	261	294	327	360	393	L1 = 33 x n + 63
L2	174	207	240	273	306	339	372	405	L2 = 33 x n + 75
L3(MP)	360	393	426	459	492	525	558	591	L3 = 33 x n + 261
L3(AP)	379.5	412.5	445.5	478.5	511.5	544.5	577.5	610.5	L3 = 33 x n + 280.5



<b>SV</b>
<b>SYJ</b>
<b>SZ</b>
<b>VF</b>
<b>VP4</b>
VQ 1/2
VQ 4/5
VQC 1/2
VQC 4/5
<b>VQZ</b>
<b>SQ</b>
<b>VFS</b>
<b>VFR</b>
<b>VQ7</b>

# VFS3000 Series Made to Order

Serial Transmission Kit Manifold: EX123/124 Integrated Type (For Output)  
Serial Transmission System



## How to Order

### How to Order Manifold

VV5FS3-01S V-08 1-02 -X279

Plug-in type  
Serial transmission kit

Stations

2	2 stations
⋮	⋮
17	17 stations

Note 1) Max. 17 stations. Add 1 station for serial unit mounting.

Note 2) Max. 17 stations for all-single wiring. (No. of valves: 16)

For the standard double wiring, the maximum number of stations is 9. (No. of valves: 8)

Port size

Symbol	P, R1, R2	A, B
02		1/4
03	1/2	3/8
M		Mixed

\* For bottom ported: 1/4 only

Thread type

Nil	Rc
T	NPTF
F	G

Combination symbol

Symbol	Port specification		Piping specification A, B
	P	R1, R2	
1	Common	Common	Side
2*			Bottom

\* Semi-standard

Compatible with SI unit U side  
mounting only

Applicable models

Symbol	SI unit part no.	Description
0	—	Without SI unit
H	EX123U-SUH1	NKE Corporation: Fieldbus H System (16 outputs)
Q	EX124U-SDN1	DevieNet (2 power supply systems)
R1	EX124U-SCS1	OMRON Corporation: CompoBus/S (16 outputs) (2 power supply systems)
R2	EX124U-SCS2	OMRON Corporation: CompoBus/S (8 outputs) (2 power supply systems)
V	EX124U-SMJ1	CC-Link (2 power supply systems)

Refer to Best Pneumatics No. 1-1 and the Operation Manual for the details of EX123/124 Integrated-type (For Output) Serial Transmission System. Please download the Operation Manual via our website, <http://www.smcworld.com>

### ● Correspondence of SI unit output numbers and solenoid valve coils

<Wiring Example 1> Double wiring (Standard)

D side

U side

SI unit output no.	1	2	3	4	5	6	7	8	9
		Double	Double	Single	Single	Single	Double	Single	Single
	A B	A B	A B	A B	A B	A B	A B	A B	
	01	23	45	67	89	1011	1213	1415	

<Wiring Example 2> Single/Double mixed wiring (Semi-standard)

D side

U side

SI unit output no.	1	2	3	4	5	6	7	8	9	10
		Double	Double	Single	Single	Single	Double	Single	Double	Single
	A B	A B	A	A	A	A B	A	A B	A	
	01	23	4	5	6	78	9	1011	11	

\* Mixed wiring is available as a semi-standard. Use the manifold specification sheet to specify this.

### How to Order Valves

VFS3 00 -5 F

Symbol

1	2 position single
2	2 position double
3	3 position closed center
4	3 position exhaust center
5	3 position pressure center
6	3 position double check

Pilot type

Nil	Internal pilot
R	External pilot

24 VDC

Pilot valve manual override

Nil	Non-locking push type (Flush)
A	Non-locking push type (Extended)
B	Locking type (Tool required)
C	Locking type (Lever)

Option

Nil	None
Z	With light/surge voltage suppressor

Coil rated voltage

Nil	None
-----	------

# 5 Port Pilot Operated Solenoid Valve Metal Seal, Plug-in/Non Plug-in **VFS3000 Series**

## Serial Transmission Kit Manifold: EX123/124 Integrated-type (For Output) Serial Transmission System

VV5FS3-01S [Model] - [Stations] [Symbol] - [Port size] [Thread] -X279

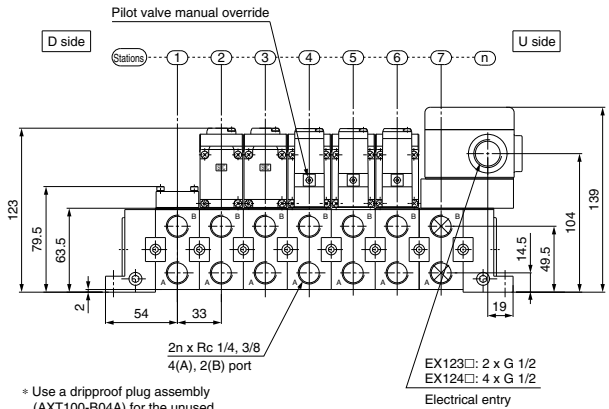
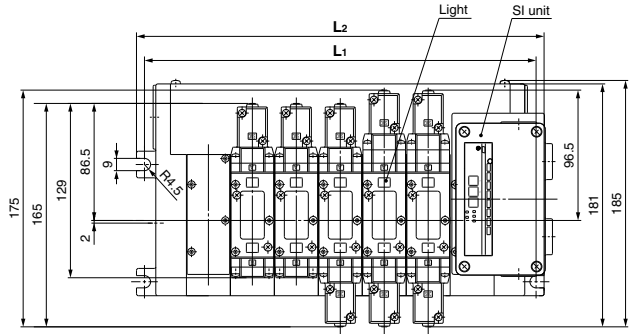
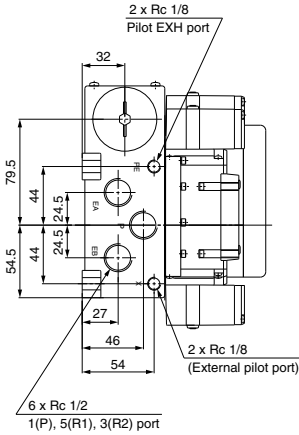

\* Use a dripproof plug assembly (AXT100-B04A) for the unused conduit port (G 1/2).

Formula  $L_1 = 33n + 63$   $L_2 = 33n + 75$   
n: Stations (Max. 17stations)

### Dimensions

n	2	3	4	5	6	7	8	9	10	11	12	13	14	15	16	17
L <sub>1</sub>	129	162	195	228	261	294	327	360	393	426	459	492	525	558	591	624
L <sub>2</sub>	141	174	207	240	273	306	339	372	405	438	471	504	537	570	603	636

Note) Actual number of manifold base stations: Add 1 SI unit mounting station to the number of valve stations.

- SV
- SYJ
- SZ
- VF
- VP4
- VQ 1/2
- VQ 4/5
- VQC 1/2
- VQC 4/5
- VQZ
- SQ
- VFS
- VFR
- VQ7

# VFS3000 Series

## Manifold Option Parts — Plug-in type, Non plug-in type

**Individual SUP spacer:**  
**VVFS3000-P-03-1 (Plug-in type)**  
**VVFS3000-P-03-2 (Non plug-in type)**

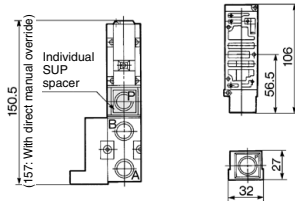

**Double check spacer:**  
**VVFS3000-22A-1 (Plug-in type)**  
**VVFS3000-22A-2 (Non plug-in type)**

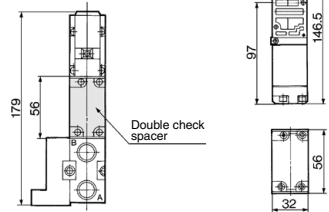

**Individual EXH spacer:**  
**VVFS3000-R-03-1 (Plug-in type)**  
**VVFS3000-R-03-2 (Non plug-in type)**

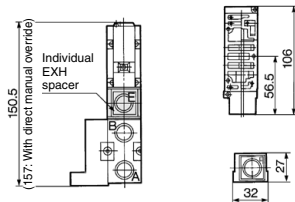

**Interface regulator/P port regulation:**  
**ARBF3050-00-P-1 (Plug-in type)**  
**ARBF3050-00-P-2 (Non plug-in type)**

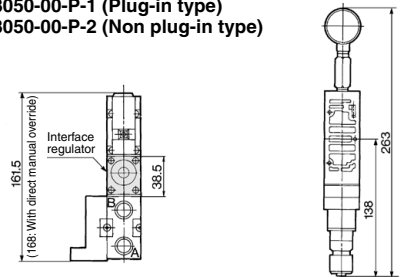

**SUP/EXH block plate: AXT636-1A**

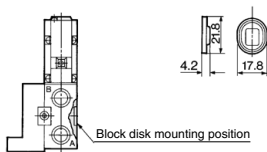

When mounting on the 2 stations integrated type manifold block, mount it after cutting the gasket.

**Interface regulator/A port regulation:**  
**ARBF3050-00-A-1 (Plug-in type)**  
**ARBF3050-00-A-2 (Non plug-in type)**

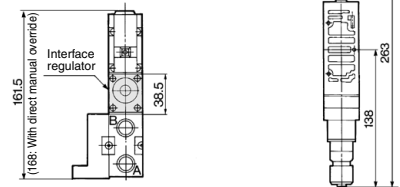

**Throttle valve spacer:**  
**VVFS3000-20A-1 (Plug-in type)**  
**VVFS3000-20A-2 (Non plug-in type)**

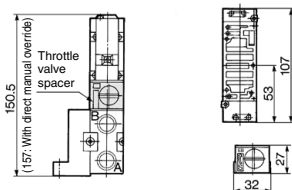

**Interface regulator/B port regulation:**  
**ARBF3050-00-B-1 (Plug-in type)**  
**ARBF3050-00-B-2 (Non plug-in type)**

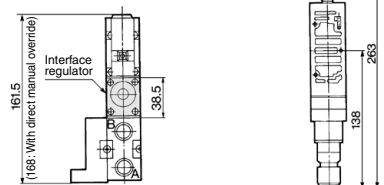

<b>SV</b>
<b>SYJ</b>
<b>SZ</b>
<b>VF</b>
<b>VP4</b>
VQ 1/2
VQ 4/5
VQC 1/2
VQC 4/5
<b>VQZ</b>
<b>SQ</b>
<b>VFS</b>
<b>VFR</b>
<b>VQ7</b>

# VFS3000 Series

## Manifold Base Construction — Plug-in type, Non plug-in type

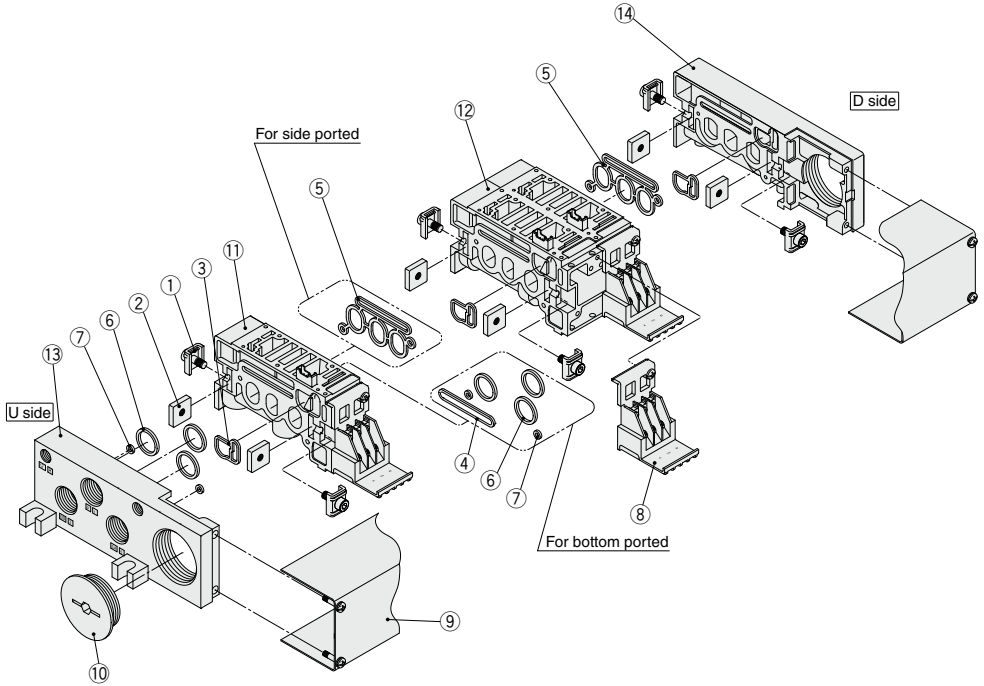

\* Manifold Base Construction: Plug-in type with terminal block (01T1).

- For increasing the manifold bases, please order the manifold block assembly number of the principle number assembly ① and ⑫.
- For plug-in type, ⑨ junction cover assembly is required.
- Manifold base is consisted of the junction of 2 and 3 station bases.

Example) U side | n | ⑥ | ⑤ | ④ | ③ | ② | ① | D side

<5 stations (Odd number)> | 1 station | 2 stations | 2 stations

<6 stations (Even number)> | 1 station | 1 station | 2 stations | 2 stations

# 5 Port Pilot Operated Solenoid Valve Metal Seal, Plug-in/Non Plug-in **VFS3000 Series**

## Replacement Parts

No.	Description	Material	Part no.
1	<b>Connection fitting assembly</b>	For 01T	VVFS3000-5-1A
2	<b>Connection fitting B</b>	For 01T	VVFS3000-5-2
3	<b>Gasket</b>	NBR	VVFS3000-7-1
4	<b>Gasket</b>	NBR	VVFS3000-8
5	<b>Gasket</b>	NBR	VVFS3000-32-1
6	<b>O-ring</b>	NBR	KA00232
7	<b>O-ring</b>	NBR	KA00020
8	<b>Terminal assembly</b>	—	VVFS3000-6A
9	<b>Junction cover assembly</b>	—	For 01T VVFS3000-4A- <sup>(Stations)<sup>(Note)</sup></sup>
		NBR	For 01S□ AZ738-22A- <sup>(Stations)<sup>(Note)</sup></sup>
10	<b>Rubber plug</b>		AXT336-9

Note) Example to indicate the number of stations when ordering the junction cover assembly.  
 • For 5 stations: VVFS3000-4A-5

## Replacement Parts: Sub Assembly

No.	Description	Part no.	Component parts	Applicable manifold base	
11	<b>Manifold block assembly (for 1 station)</b>	Side ported	VVFS3000-1A-1- <sup>02</sup> <sub>03</sub> <sup>Note 1)</sup>	Manifold block ①, Metal joint ①, ②, Gasket ③, ⑤, Terminal ⑧, Receptacle assembly	Plug-in type
			VVFS3000-1A-2- <sup>02</sup> <sub>03</sub> <sup>Note 1)</sup>	Manifold block ①, Metal joint ①, ②, Gasket ③, ⑤	Non plug-in type
		Bottom ported	VVFS3000-1A-1-B <sup>02</sup> <sub>03</sub> <sup>Note 1)</sup>	Manifold block ①, Metal joint ①, ②, Gasket ③, ④, O-ring ⑥, ⑦, Terminal ⑧, Receptacle assembly	Plug-in type
			VVFS3000-1A-2-B <sup>02</sup> <sub>03</sub> <sup>Note 1)</sup>	Manifold block ①, Metal joint ①, ②, Gasket ③, ④, O-ring ⑥, ⑦	Non plug-in type
12	<b>Manifold block assembly (for 2 stations)</b> <sup>Note 2)</sup>	VVFS3000-1A2-1- <sup>02</sup> <sub>03</sub> <sup>Note 1)</sup>	Manifold block ①, ②, Metal joint ①, ②, Gasket ③, ⑤, Terminal ⑧, Receptacle assembly	Plug-in type	
		VVFS3000-1A2-2- <sup>02</sup> <sub>03</sub> <sup>Note 1)</sup>	Manifold block ①②, Metal joint ①, ②, Gasket ③, ⑤	Non plug-in type	
13	<b>End plate (U side) assembly</b>	VVFS3000-2A-1	End plate (U) ⑬, Metal joint ①, ②, O-ring ⑥, ⑦	Plug-in type	
		VVFS3000-2A-2	End plate (U) ⑬, Metal joint ①, ②, O-ring ⑥, ⑦	Non plug-in type	
14	<b>End plate (D side) assembly</b>	VVFS3000-3A-1	End plate (D) ⑭, Metal joint ①, ②, Gasket ③	Plug-in type	
		VVFS3000-3A-2	End plate (D) ⑭, Metal joint ①, ②, Gasket ③	Non plug-in type	

Note 1) 02: A, B port size Rc 1/4, 03: A, B port size Rc 3/8  
 Note 2) The bottom ported type manifold block for 2 stations is not available.

SV  
 SYJ  
 SZ  
 VF  
 VP4  
 VQ 1/2  
 VQ 4/5  
 VQC 1/2  
 VQC 4/5  
 VQZ  
 SQ  
 VFS  
 VFR  
 VQ7

# 5 Port Pilot Operated Solenoid Valve Metal Seal, Plug-in/Non Plug-in

# VFS4000 Series



(Details → P. 1006)

## Model

Type of actuation		Model		Port size	Flow rate characteristics <sup>(1)</sup>						Max. operating cycle (cpm) <sup>(1)</sup>	Response time (ms) <sup>(2)</sup>	Weight (kg) <sup>(3)(4)</sup>
					1 → 4/2 (P → A/B)			4/2 → 5/3 (A/B → R1/R2)					
					C [dm <sup>3</sup> /(s·bar)]	b	Cv	C [dm <sup>3</sup> /(s·bar)]	b	Cv			
2 position	Single	VFS4100	VFS4110	3/8	11	0.18	2.6	12	0.20	2.8	1,000	40 or less	0.63
				1/2	12	0.15	2.8	12	0.22	3.1			
	Double	VFS4200	VFS4210	3/8	11	0.18	2.6	12	0.20	2.8	1,200	15 or less	0.75
				1/2	12	0.15	2.8	12	0.22	3.1			
3 position	Closed center	VFS4300	VFS4310	3/8	10	0.18	2.5	10	0.14	2.3	600	50 or less	0.82
				1/2	11	0.18	2.7	11	0.22	2.6			
	Exhaust center	VFS4400	VFS4410	3/8	11	0.16	2.6	10	0.15	2.3	600	50 or less	0.82
				1/2	12	0.15	2.9	10	0.15	2.4			
	Pressure center	VFS4500	VFS4510	3/8	11	0.22	2.7	11	0.22	2.7	600	50 or less	0.82
				1/2	12	0.22	2.9	11	0.22	2.8			
	Double check	VFS4600	VFS4610	3/8	6.3	—	—	6.5	—	—	200	55 or less	1.71
				1/2	6.8	—	—	6.8	—	—			

Note 1) Based on JIS B 8419: 2010 (once per 30 days) for the minimum operating frequency.

Note 2) Based on JIS B 8419-2010. (The value at supply pressure 0.5 MPa, ambient/fluid temperature (-20°C))

However, this excludes when in an adhered state. (Be aware that after long periods of holding time, there may be delays in the initial response time.)

Note 3) The figures in the above list are for without sub-plate. In the case of with plug-in sub-plate and with non plug-in sub-plate, add 0.50 kg and 0.43 kg respectively.

Note 4) "Note 1)" and "Note 2)" are with controlled clean air.

Compact yet provides a large flow capacity  
1/2: C: 12 dm<sup>3</sup>/(s·bar)

Low power consumption: 1.8 W DC

Easy maintenance

2 types of sub-plates:

Plug-in and non plug-in

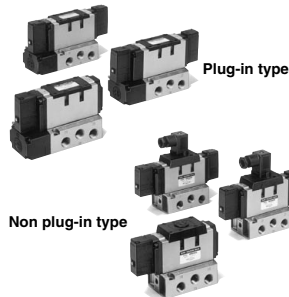

## Symbol

2 position	3 position
Single (A4, 2(B))  5 13 (R1)(P/R2)	Closed center (A4, 2(B))  5 13 (R1)(P/R2)
Double (A4, 2(B))  5 13 (R1)(P/R2)	Exhaust center (A4, 2(B))  5 13 (R1)(P/R2)
	Pressure center (A4, 2(B))  5 13 (R1)(P/R2)
	Double check (A4, 2(B))  5 13 (R1)(P/R2)

## Standard Specifications

Valve specifications	Fluid	Air		
	Maximum operating pressure	1.0 MPa		
	Minimum operating pressure	2 position	0.1 MPa	
		3 position	0.15 MPa	
	Proof pressure	1.5 MPa		
	Ambient and fluid temperature	-10 to 60°C <sup>(1)</sup>		
	Lubrication	Non-lube <sup>(2)</sup>		
Pilot valve manual override	Non-locking push type (Flush)			
Impact/Vibration resistance	150/50 m/s <sup>2</sup> <sup>(3)</sup>			
Electricity specifications	Enclosure	Type E: Dustproof (Equivalent to IP50), Type F: Dripproof (Equivalent to IP52), Type D: Splashproof (Equivalent to IP54) <sup>(4)(5)</sup>		
	Coil rated voltage	100, 200 VAC, 50/60 Hz; 24 VDC		
	Allowable voltage fluctuation	-15 to +10% of rated voltage		
	Coil insulation type	Class B or equivalent (130°C) <sup>(6)</sup>		
	Apparent power (Power consumption) AC	Inrush	5.6 VA/50 Hz, 5.0 VA/60 Hz	
		Holding	3.4 VA (2.1 W)/50 Hz, 2.3 VA (1.5 W)/60 Hz	
	Power consumption DC	1.8 W (2.04 W: With light/surge voltage suppressor)		
		Plug-in type	Conduit terminal	
Electrical entry	Non plug-in type	Grommet terminal, DIN terminal		

Note 1) Use dry air at low temperatures.

Note 2) Use turbine oil Class 1 (ISO VG32), if lubricated.

Note 3) Impact resistance: No malfunction occurred when it is tested with a drop tester in the axial direction and at the right angles to the main valve and armature in both energized and de-energized states every once for each condition. (Values at the initial period)

Vibration resistance: No malfunction occurred in a one-sweep test between 45 and 2000 Hz. Test was performed at both energized and de-energized states in the axial direction and at the right angles to the main valve and armature. (Values at the initial period)

Note 4) Based on JIS C 0920.

Note 5) Based on JIS C 4003.

Note 6) The F and D type enclosures described above show those without the light/surge voltage suppressor. The F and D type enclosures with the light/surge voltage suppressor are equivalent to IP50.

## Option Specifications

Pilot type		External pilot <sup>(Note)</sup>
Manual override	Main valve	Direct manual override
	Pilot valve	Non-locking push type (Extended), Locking type (Tool required), Locking type (Lever)
Coil rated voltage	110 to 120, 220, 240 VAC, 50/60 Hz	
	12, 100 VDC	
Porting specifications		Bottom ported
Option		With light/surge voltage suppressor

Note) Operating pressure: 0 to 1.0 MPa

Pilot pressure 2 position: 0.1 to 1.0 MPa, 3 position: 0.15 to 1.0 MPa



# 5 Port Pilot Operated Solenoid Valve Metal Seal, Plug-in/Non Plug-in **VFS4000 Series**



## How to Order



Plug-in

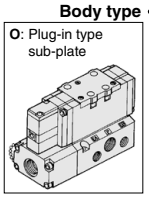

**Body type**

**O:** Plug-in type sub-plate

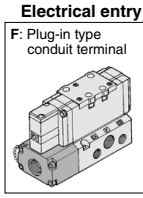

**Electrical entry**

**F:** Plug-in type conduit terminal

**Porting specifications**

**N<sup>II</sup>** Side ported  
**B<sup>II</sup>** Bottom ported

\* In the case of external pilot (Semi-standard), bottom piping is not available.

**Port size**

<b>Nil</b>	Without sub-plate
<b>03</b>	3/8
<b>04*</b>	1/2

\* EA, EB: 3/8

**Thread type**

<b>Nil</b>	Rc
<b>N<sup>*</sup></b>	NPT
<b>T<sup>*</sup></b>	NPTF
<b>F<sup>*</sup></b>	G

\* Semi-standard

**CE/UKCA-compliant**

<b>Nil</b>	—
<b>Q</b>	CE/UKCA-compliant

Non plug-in

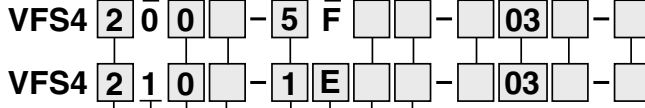

**Option**

<b>Nil</b>	None
<b>Z</b>	With light/surge voltage suppressor

**Electrical entry**

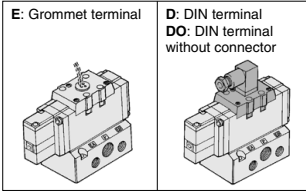

**Coil rated voltage**

<b>1</b>	100 VAC, 50/60 Hz
<b>2</b>	200 VAC, 50/60 Hz
<b>3*</b>	110 to 120 VAC, 50/60 Hz
<b>4*</b>	220 VAC, 50/60 Hz
<b>5</b>	24 VDC
<b>6*</b>	12 VDC
<b>7*</b>	240 VAC, 50/60 Hz

\* Semi-standard  
For other rated voltages, please consult with SMC.

**Pilot type**

<b>Nil</b>	Internal pilot
<b>R*</b>	External pilot

\* Semi-standard

**Pilot valve Manual override**

**Nil:** Non-locking push type (Flush)



**A\*:** Non-locking push type (Extended)



**B\*:** Locking type (Tool required)



**C\*:** Locking type (Lever)



\* Semi-standard

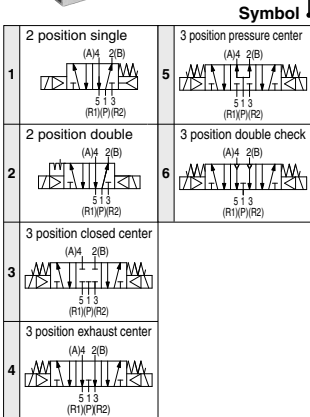

\* Reverse pressure: Can be used by external pilot specifications.

**Body type**

**1:** Non plug-in type sub-plate

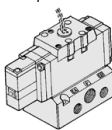

**Body option**

<b>0</b>	Standard
<b>1*</b>	Direct manual override

\* Semi-standard

## How to Order Pilot Valve Assembly

**SF4 - 1 F - 30**

**Coil rated voltage**

<b>1</b>	100 VAC, 50/60 Hz
<b>2</b>	200 VAC, 50/60 Hz
<b>3*</b>	110 to 120 VAC, 50/60 Hz
<b>4*</b>	220 VAC, 50/60 Hz
<b>5</b>	24 VDC
<b>6*</b>	12 VDC
<b>7*</b>	240 VAC, 50/60 Hz

\* Semi-standard  
For other rated voltages, please consult with SMC.  
\*\* Refer to page 1010 for voltage conversion.

**Manual override**

**Nil** Non-locking push type (Flush)

**A\*** Non-locking push type (Extended)

**B\*** Locking type (Tool required)

**C\*** Locking type (Lever)

\* Semi-standard

# VFS4000 Series

## Cylinder Speed Chart

Use as a guide for selection.  
Please confirm the actual conditions with SMC Sizing Program.

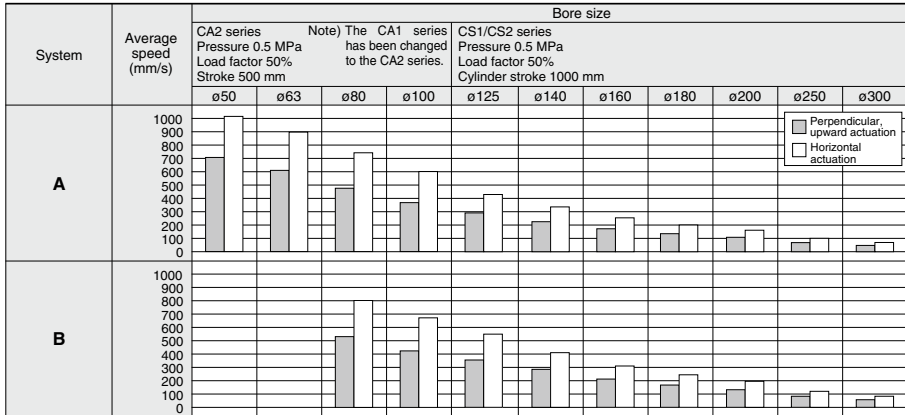

### System Components

System	Solenoid valve	Speed controller	Silencer	SGP (Steel pipe) Port size x Length
A	VFS4000 Series Rc $\frac{3}{8}$	AS420-03 (S = 73 mm <sup>2</sup> )	AN30-03 (S = 60 mm <sup>2</sup> )	10A x 1
B	VFS4000 Series Rc $\frac{1}{2}$	AS420-04 (S = 97 mm <sup>2</sup> )	AN40-04 (S = 90 mm <sup>2</sup> )	15A x 1

- \* It is when the cylinder is extending that is meter-out controlled by speed controller which is directly connected with cylinder, and its needle valve with being fully open.
- \* The average velocity of the cylinder is what the stroke is divided by the total stroke time.
- \* Load factor: ((Load mass x 9.8)/Theoretical force) x 100%

## Double Check Spacer/Specifications

### Can hold an intermediate cylinder position for an extended time

If the double check spacer with a built-in double check valve is combined, it will enable the cylinder to stop in the intermediate stroke and maintain its position for a long time without being affected by the leakage between the spools.

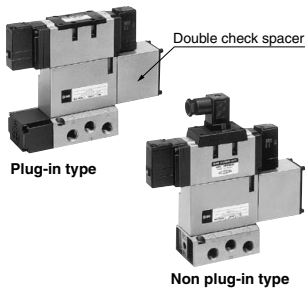

### Specifications

Double check spacer part no.	Plug-in type	Non plug-in type
	VVFS4000-22A-1	VVFS4000-22A-2
Applicable valve model	VFS4400-□F	VFS4410-□D VFS4410-□E

### ⚠ Caution

- In the case of 3 position double check valve (VFS46□0), check the leakage from piping and fittings in between valve and cylinder by means of synthetic detergent solutions, and ensure that there is no such leakage found there. Also check the leakage from cylinder seal and piston seal. If there is any leakage, sometimes the cylinder, when valve is de-energized, can move without stopping at intermediate position.
- Be aware that if the exhaust side is restricted excessively, the intermediate stopping accuracy will decrease and will lead to improper intermediate stops.

### Check Valve Operation

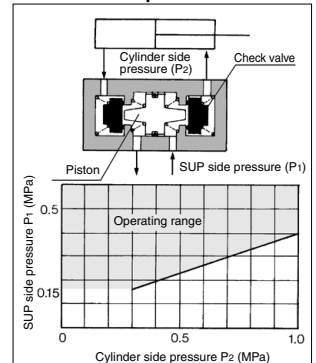

- The combination of VFS41 $\frac{1}{2}$ 0, VFS42 $\frac{1}{2}$ 0 and Double check spacer for prevention of falling at the stroke end but cannot hold the intermediate position of the cylinder.

## Construction

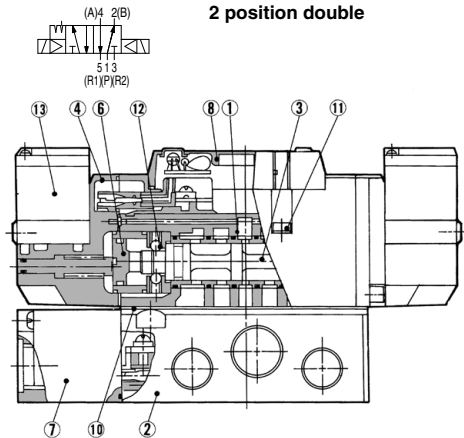
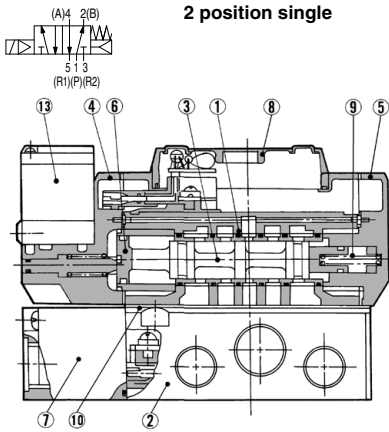

### 3 position closed center/exhaust center/pressure center

**Closed center**



**Exhaust center**

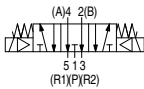

**Pressure center**

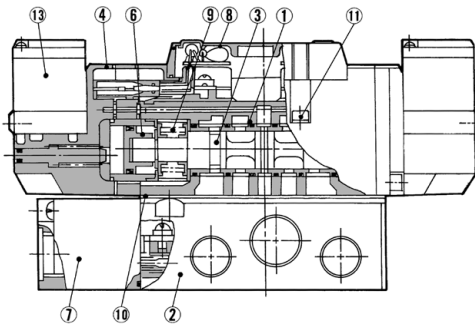

## Component Parts

No.	Description	Material	Note
1	Body	Aluminum die-casted	—
2	Sub-plate	Aluminum die-casted	—
3	Spool/Sleeve	Stainless steel	—
4	Adapter plate	Resin	—
5	End plate	Resin	—
6	Piston	Resin	—
7	Junction cover	Resin	—
8	Light cover	Resin	—
9	Return spring	Stainless steel	—
10	Gasket	HNBR	—
11	Hexagon socket head screw	Steel	—
12	Detent assembly	—	—
13	Pilot valve assembly	—	—

\* Refer to "How to Order Pilot Valve Assembly" on page 963.



## Sub-plate Assembly Part No.

Plug-in	VFS4000-P-R <sub>02</sub> (N, T, F)
Non plug-in	VFS4000-S-R <sub>02</sub> (N, T, F)

\* Mounting bolt and gasket are not included.

## Sub-plate Assembly (For External Pilot) Part No.

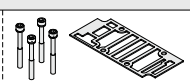
Plug-in	VFS4000-P-R <sub>03</sub> (N, T, F)
Non plug-in	VFS4000-S-R <sub>03</sub> (N, T, F)

Part no. for mounting bolt and gasket	Note
BG-VFS4000	Plate gasket type (Earlier than July, 2010) <sup>Note</sup> 
BG-VFS4000-1	Groove gasket type (After August 2010) <sup>Note</sup> 

Note) When ordering the parts shown above for the replacement, note that the described date may slightly vary depending on the product being used.

# VFS4000 Series

## Plug-in — 2 Position single/Double/3 Position closed center/Exhaust center/Pressure center/Double check

### 2 position single: VFS4100-□F(Z)

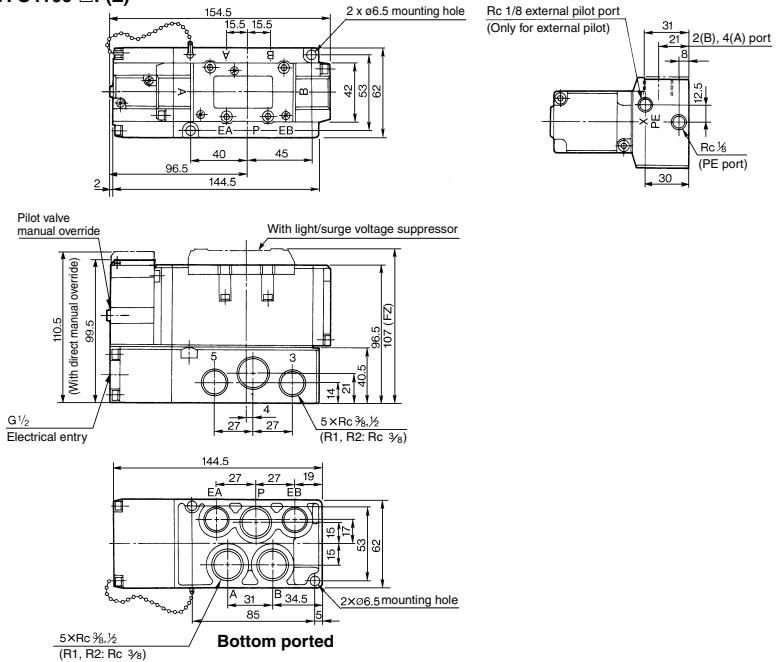

### 2 position double: VFS4200-□F(Z)

### 3 position closed center: VFS4300-□F(Z)

### 3 position exhaust center: VFS4400-□F(Z)

### 3 position pressure center: VFS4500-□F(Z)

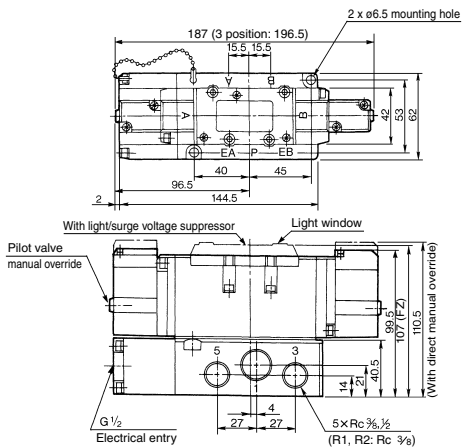

### 3 position double check: VFS4600-□F(Z)

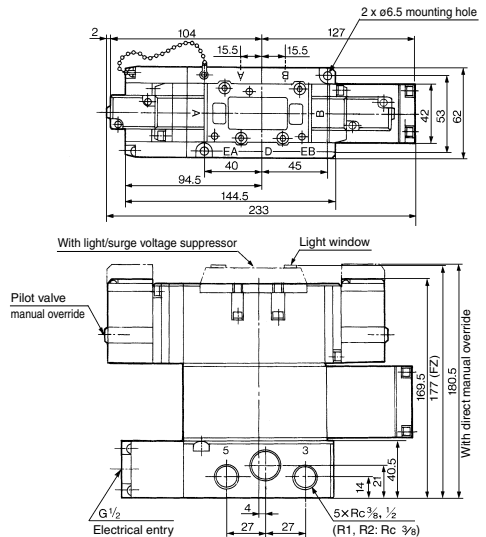

**Non Plug-in — 2 Position single/Double/3 Position closed center/Exhaust center/Pressure center/Double check**

**2 position single: VFS4110-□E(Z), VFS4110-□D(Z)**

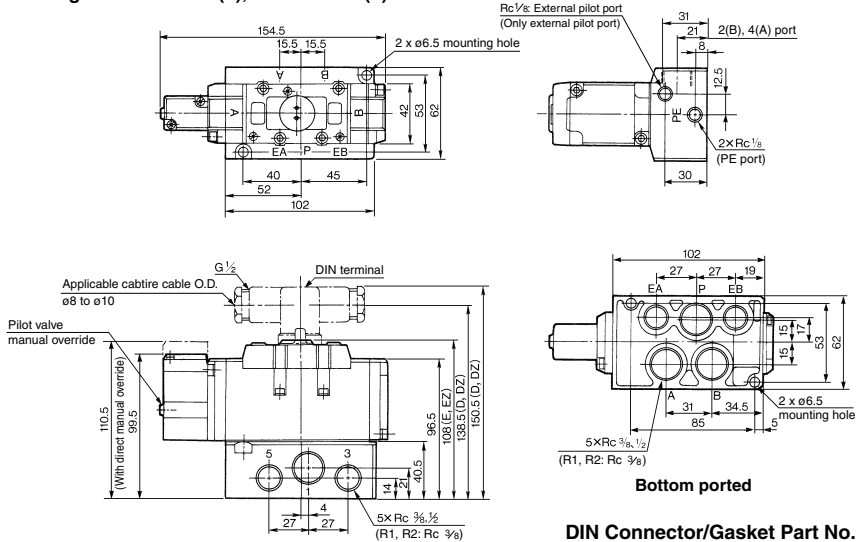

**Bottom ported**

**DIN Connector/Gasket Part No.**

Description	Part No.
Connector	UKL-S1
Gasket	DXT087-27-2

**2 position double: VFS4210-□E(Z), VFS4210-□D(Z)**  
**3 position closed center: VFS4310-□E(Z), VFS4310-□D(Z)**  
**3 position exhaust center: VFS4410-□E(Z), VFS4410-□D(Z)**  
**3 position pressure center: VFS4510-□E(Z), VFS4510-□D(Z)**

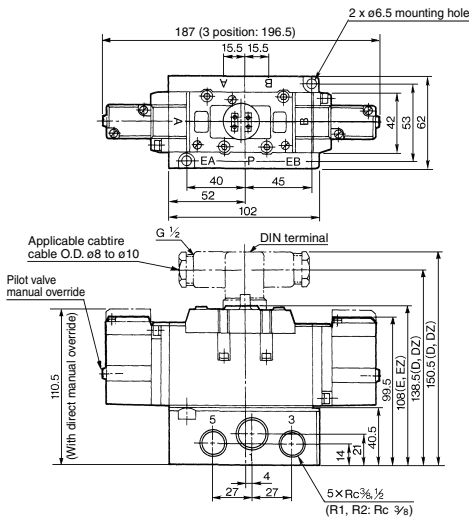

**3 position double check: VFS4610-□E(Z), VFS4610-□D(Z)**

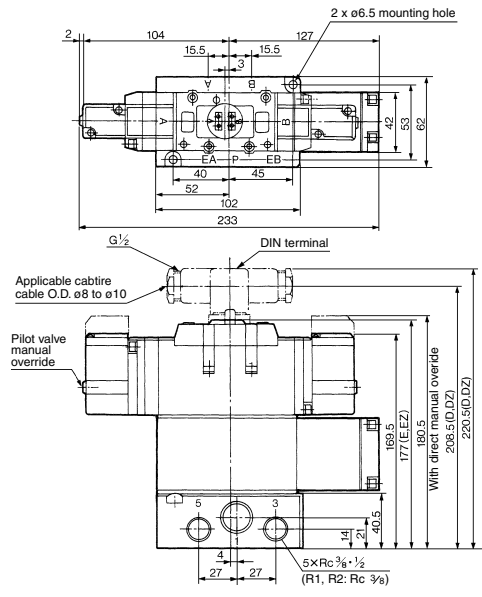

- SV
- SYJ
- SZ
- VF
- VP4
- VQ 1/2
- VQ 4/5
- VQC 1/2
- VQC 4/5
- VQZ
- SQ
- VFS
- VFR
- VQ7

# VFS4000 Series Manifold Specifications



## Plug-in Type: With Terminal Block

- Since lead wires of solenoid valve are connected with the terminals on upper surface of terminal block, corresponding lead wires from power source can be wired at the bottom of terminal block.

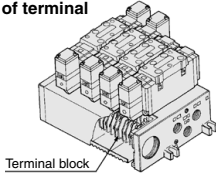

**VV5FS4 - 01T - 06 1 - 03**

VFS4000 Series Manifold  
Plug-in type with terminal block

**Stations**

02	2 stations
:	:
10	10 stations

**Port size**

Symbol	P, R1, R2	A, B
03		3/8
04	1/2	1/2
M		Mixed

**Thread type**

Nil	Rc
N <sup>#</sup>	NPT
T <sup>#</sup>	NPTF
F <sup>#</sup>	G

**CE/UKCA-compliant**

Nil	—
Q	CE/UKCA-compliant

**Symbol**

Symbol	Passage	Porting specifications (A, B)
	P	R1, R2
1	Common	Common
2	Common	Common

**Porting specifications (A, B)**

Symbol	Passage	Porting specifications (A, B)
	P	R1, R2
1	Common	Common
2	Common	Common

\* For bottom ported, 3/8 is only available.  
\* Semi-standard

## Plug-in Type: With Multi-connector (Wiring specifications: Refer to page 1013.)

- Quick wiring permits easier installation.

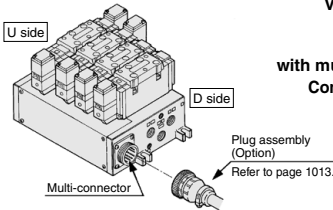

**VV5FS4 - 01C D - 05 2 - 03**

VFS4000 Series Manifold  
Plug-in type with multi-connector

**Stations**

02	2 stations
:	:
08 <sup>#</sup>	8 stations

\* Max. 8 stations

**Port size**

Symbol	P, R1, R2	A, B
03		3/8
04	1/2	1/2
M		Mixed

**Thread type**

Nil	Rc
N <sup>#</sup>	NPT
T <sup>#</sup>	NPTF
F <sup>#</sup>	G

**CE/UKCA-compliant**

Nil	—
Q	CE/UKCA-compliant

**Connector mounting direction**

D	D side mounting
U	U side mounting

**Symbol**

Symbol	Passage	Porting specifications (A, B)
	P	R1, R2
1	Common	Common
2	Common	Common

**Porting specifications (A, B)**

Symbol	Passage	Porting specifications (A, B)
	P	R1, R2
1	Common	Common
2	Common	Common

\* For bottom ported, 3/8 is only available.  
\* Semi-standard

## Plug-in Type With: D-sub Connector (Wiring specifications: Refer to page 1013.)

- Wide range of interchangeability (MIL Spec D-sub connector terminal 25 pcs attached.)
- Quick wiring permits easier installation.

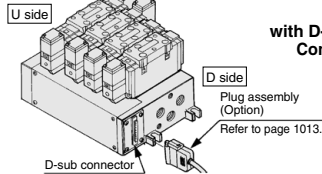

**VV5FS4 - 01F D - 06 1 - 03**

VFS4000 Series Manifold  
Plug-in type with D-sub connector

**Stations**

02	2 stations
:	:
08 <sup>#</sup>	8 stations

\* Max. 8 stations

**Port size**

Symbol	P, R1, R2	A, B
03		3/8
04	1/2	1/2
M		Mixed

**Thread type**

Nil	Rc
N <sup>#</sup>	NPT
T <sup>#</sup>	NPTF
F <sup>#</sup>	G

**CE/UKCA-compliant**

Nil	—
Q	CE/UKCA-compliant

**Connector mounting direction**

D	D side mounting
U	U side mounting

**Symbol**

Symbol	Passage	Porting specifications (A, B)
	P	R1, R2
1	Common	Common
2	Common	Common

**Porting specifications (A, B)**

Symbol	Passage	Porting specifications (A, B)
	P	R1, R2
1	Common	Common
2	Common	Common

\* For bottom ported, 3/8 is only available.  
\* Semi-standard

## Non Plug-in Type: Grommet Terminal, DIN Terminal

- Wiring for every valve.

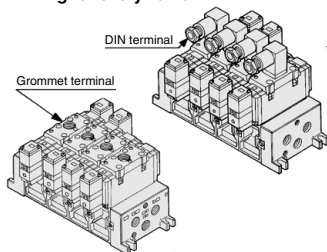

**VV5FS4 - 10 - 05 2 - 03**

VFS4000 Series Manifold  
Non plug-in type

**Stations**

02	2 stations
:	:
10	10 stations

**Port size**

Symbol	P, R1, R2	A, B
03		3/8
04	1/2	1/2
M		Mixed

**Thread type**

Nil	Rc
N <sup>#</sup>	NPT
T <sup>#</sup>	NPTF
F <sup>#</sup>	G

**CE/UKCA-compliant**

Nil	—
Q	CE/UKCA-compliant

**Symbol**

Symbol	Passage	Porting specifications (A, B)
	P	R1, R2
1	Common	Common
2	Common	Common

**Porting specifications (A, B)**

Symbol	Passage	Porting specifications (A, B)
	P	R1, R2
1	Common	Common
2	Common	Common

\* For bottom ported, 3/8 is only available.  
\* Semi-standard

# 5 Port Pilot Operated Solenoid Valve Metal Seal, Plug-in/Non Plug-in **VFS4000 Series**

## How to Order Manifold Assembly

Please indicate manifold base type, corresponding valve, and option parts.

### <Example>

- Plug-in type with terminal block: 6 stations  
(Manifold base) **VV5FS4-01T-061-03** .....1  
(2 position single) **VFS4100-5FZ** .....3  
(2 position double) **VFS4200-5FZ** .....2  
(Blanking plate) **VVFS4000-10A** .....1
- Non plug-in type: 6 stations  
(Manifold base) **VV5FS4-10-061-04** .....1  
(2 position single) **VFS4110-5D** .....5  
(3 position exhaust center) **VFS4410-5D** .....1  
(Individual EXH spacer) **VVFS4000-R-04-2** .....1

## Manifold Specifications

Base model	Wiring	Poring specifications		Port size Rc		Stations	External pilot	Applicable <sup>(2)</sup> valve model
		A, B port	P, EA, EB	A, B	A, B			
Plug-in type <b>VV5FS4-01</b> □	<ul style="list-style-type: none"> <li>• With terminal block</li> <li>• With multi-connector</li> <li>• With D-sub connector</li> </ul>	Side/ Bottom	1/2	3/8, 1/2	2 to 10 <sup>(1)</sup>	Yes <sup>(2)</sup>	VFS4□□□(R)-□F(Z)	
Non plug-in type <b>VV5FS4-10</b>	<ul style="list-style-type: none"> <li>• DIN terminal</li> <li>• Grommet terminal</li> </ul>						VFS4□□□(R)-□□(Z) VFS4□□□(R)-□□E(Z)	

Note 1) With multi-connector, or with D-sub connector: 8 stations max.

Note 2) It is possible to mount the standard valve and the external pilot type valve together.

## Flow Rate Characteristics at the Number of Manifold Stations (Operated individually)

Model	Passage/Stations	Station 1	Station 5	Station 10	
VV5FS4	1 → 4/2 (P → A/B)	C [dm <sup>3</sup> /(s-bar)]	10.5	10.5	10.5
		b	0.20	0.20	0.20
		Cv	2.5	2.5	2.5
	4/2 → 5/3 (A/B → R1/R2)	C [dm <sup>3</sup> /(s-bar)]	11	11	11
		b	0.20	0.20	0.20
		Cv	2.9	2.9	2.9

\* Port size: Rc 1/2

SV

SYJ

SZ

VF

VP4

VQ

1/2

VQ

4/5

VQC

1/2

VQC

4/5

VQZ

SQ

VFS

VFR

VQ7

# VFS4000 Series

## Manifold Option Parts Assembly

### Individual SUP spacer

An individual SUP spacer set on manifold block can form SUP port for every valve.

Body type	Plug-in type	Non plug-in type
Part no.	VVFS4000-P-03-1	VVFS4000-P-03-2

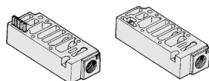

### Individual EXH spacer

An individual EXH spacer set on manifold block can form EXH port for every valve. (common EXH type)

Body type	Plug-in type	Non plug-in type
Part no.	VVFS4000-R-04-1	VVFS4000-R-04-2

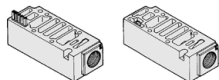

### \* SUP block plate

When supplying manifold with more than two different pressures, high and low, insert a block plate in between stations subjected to Plug-in different pressures.

Body type	Plug-in type	Non plug-in type
Part no.	AXT634-10A	

### \* EXH block plate

When valve exhaust affects the other stations on the circuit or when a reverse pressure valve is used to a standard manifold valve, insert EXH block plate in between stations to separate valve exhaust.

Body type	Plug-in type	Non plug-in type
Part no.	AXT634-11A	



EXH block plate

SUP block plate

### Throttle valve spacer

Needle valve set on the manifold block can control cylinder speed by throttling exhaust.

Body type	Plug-in type	Non plug-in type
Part no.	VVFS4000-20A-1	VVFS4000-20A-2

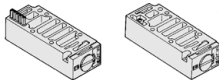

### Double check spacer

If the double check spacer with a built-in double check valve is combined, it will enable the cylinder to stop in the intermediate stroke and maintain its position for a long time without being affected by the leakage between the spools.

Body type	Plug-in type	Non plug-in type
Part no.	VVFS4000-22A-1	VVFS4000-22A-2

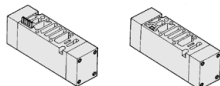

### Interface regulator

Interface regulator set on manifold block can regulate the pressure to each valve. (Refer to page 1011 for "Flow Rate Characteristics".)

Body type	Plug-in type	Non plug-in type
P port regulation	ARBF4050-00-P-1	ARBF4050-00-P-2
A port regulation	ARBF4050-00-A-1	ARBF4050-00-A-2
B port regulation	ARBF4050-00-B-1	ARBF4050-00-B-2

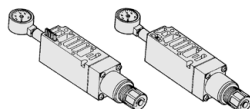

### Blanking plate

It is used by attaching on the manifold block for being prepared for removing a valve for maintenance reasons or planning to mount a spare valve, etc.

Body type	Plug-in type	Non plug-in type
Part no.	VVFS4000-10A	

## Manifold Option

### With exhaust cleaner

#### Plug-in type/Non Plug-in type

- Valve exhaust noise damping: 35 dB or more.
- Oil mist collection: Rate of collection 99.9% or more.
- Piping process reduced.

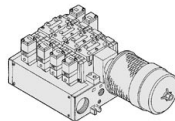

For details, refer to page 973.

### With control unit

#### Plug-in type/Non Plug-in type

- Filter, regulation valve, pressure switch and air release valve are all combined to form one unit.
- Piping processes are eliminated.

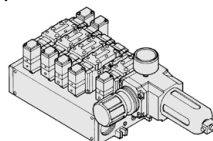

For details, refer to page 975.

### Made to Order

#### Manifold with serial transmission kit

#### Plug-in type

- Solenoid valve wiring process reduced considerably.

For details, refer to page 978.



**Manifold — Plug-in type, Non plug-in type**

**Plug-in type (With terminal block): VV5FS4-01T-Station 1- Port size**

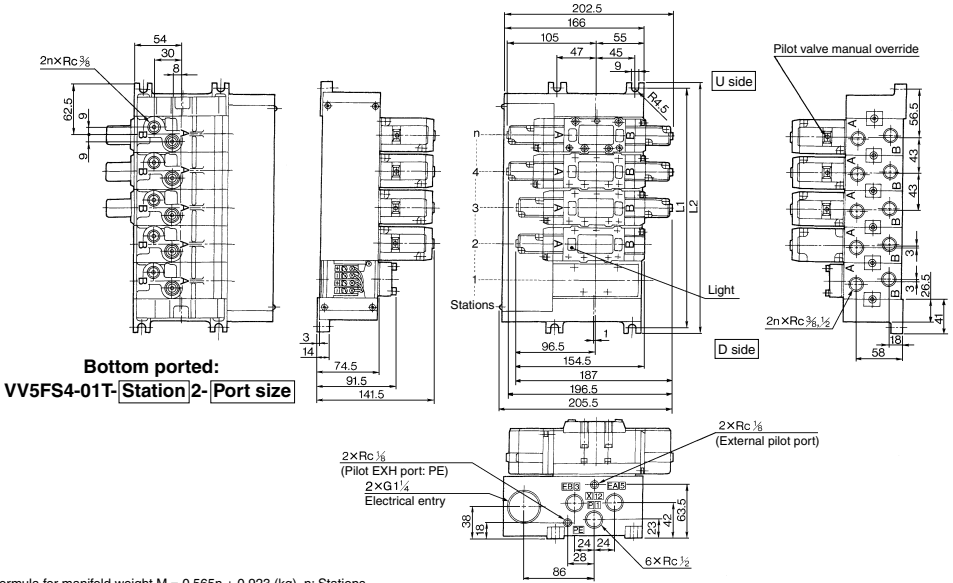

**Bottom ported:  
VV5FS4-01T-Station 2-Port size**

Formula for manifold weight M = 0.565n + 0.923 (kg) n: Stations

**Non plug-in type: VV5FS4-10-Station 1- Port size**

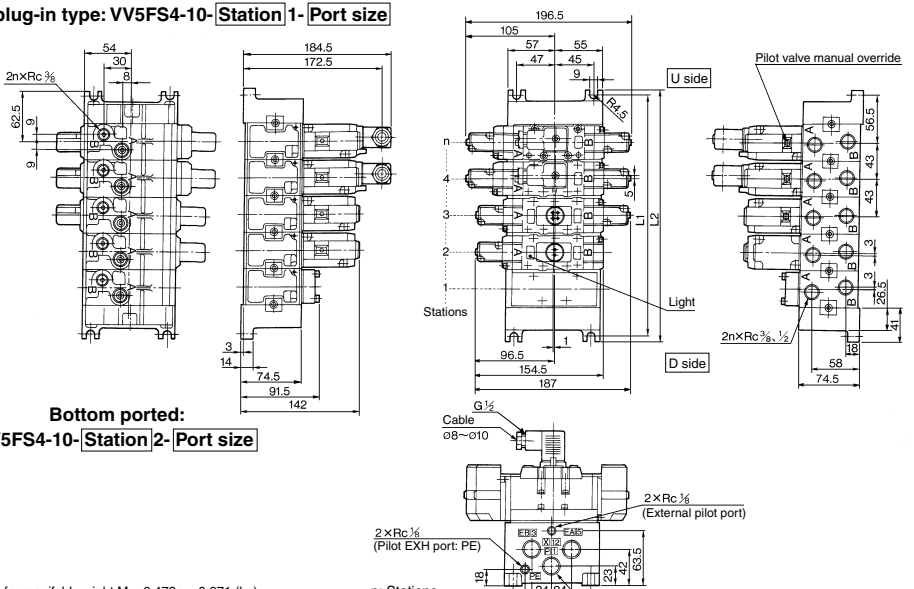

**Bottom ported:  
VV5FS4-10-Station 2-Port size**

Formula for manifold weight M = 0.478n + 0.671 (kg) n: Stations

Station	2	3	4	5	6	7	8	9	10	Formula
L <sub>1</sub>	156	199	242	285	328	371	414	457	500	L <sub>1</sub> = 43 x n + 70
L <sub>2</sub>	168	211	254	297	340	383	426	469	512	L <sub>2</sub> = 43 x n + 82

- SV
- SYJ
- SZ
- VF
- VP4
- VQ 1/2
- VQ 4/5
- VQC 1/2
- VQC 4/5
- VQZ
- SQ
- VFS
- VFR
- VQ7

# VFS4000 Series

## Manifold — Plug-in type with multi-connector/D-sub connector

Plug-in type with multi-connector: **VV5FS4-01CD-Station 1-Port size**, **VV5FS4-01CU-Station 1-Port size**

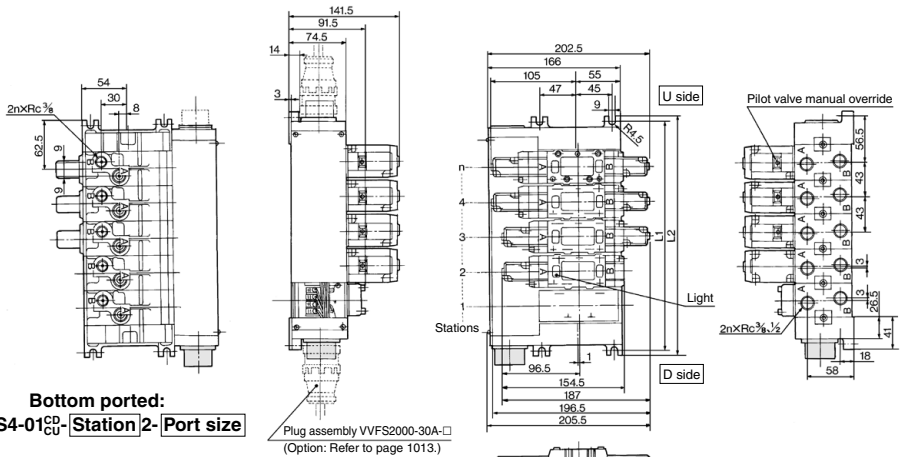

Formula for manifold weight  $M = 0.57n + 1.011$  (kg) n: Station  
 \* Wiring specifications: Refer to page 1013.

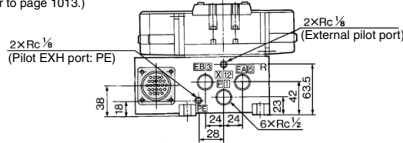

Plug-in type with D-sub connector: **VV5FS4-01FD-Station 1-Port size**, **VV5FS4-01FU-Station 1-Port size**

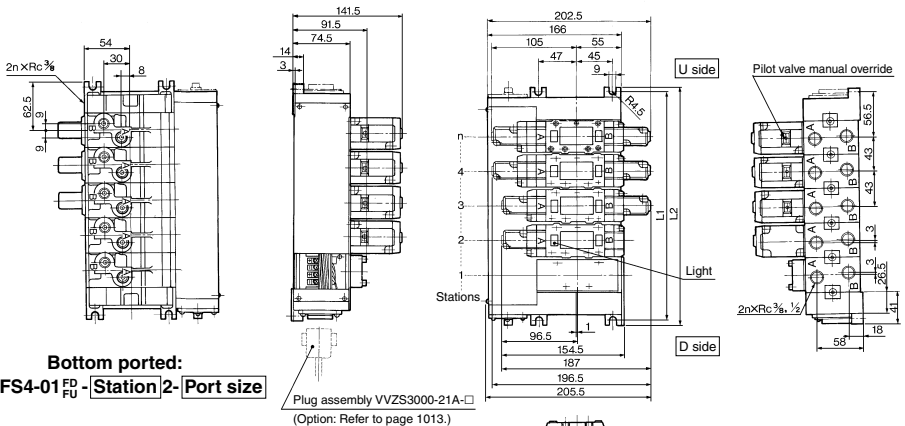

Formula for manifold weight  $M = 0.57n + 0.935$  (kg)  
 \* Wiring specifications: Refer to page 1013.

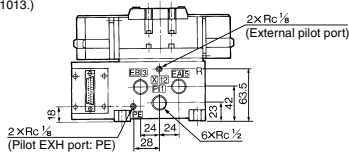

		n: Stations							
L	Station	2	3	4	5	6	7	8	Formula
L <sub>1</sub>		156	199	242	285	328	371	414	L <sub>1</sub> = 43 x n + 70
L <sub>2</sub>		168	211	254	297	340	383	426	L <sub>2</sub> = 43 x n + 82

## Manifold with Exhaust Cleaner

- Serves to protect working environment.
- Valve exhaust noise dampening: 35 dB or more.
- Collection rate of drainage and oil mist: 99.9% or more.
- Piping work is reduced.

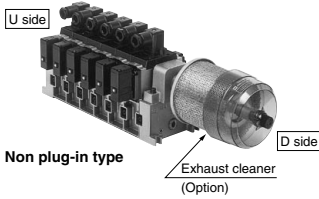
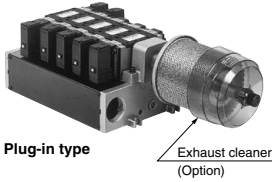

### Manifold Specifications

Manifold	Plug-in type: VVFS4-01□	Non plug-in type: VVFS4-10
Wiring	With terminal block With multi-connector With D-sub connector	DIN terminal Grommet terminal
Applicable valve model	VFS4□00-□F	VFS4□10-□D, VFS4□10-□E
Porting specifications	Common SUP/Common EXH	
	2(B), 4(A) port	Side: 3/8, 1/2, Bottom: 3/8 (Option)
Rc	1(P), 3(R2), 5(R1) port	P: 1/2, EXH: 1, 1 1/2
Stations	2 to 10 <sup>(1)</sup>	
Applicable exhaust cleaners	AMC610-10 (Connecting port size R 1), AMC810-14 (Connecting port size R 1 1/2) <sup>(2)</sup>	

Note 1) With multi-connector, or with D-sub connector: 8 stations max.

Note 2) Stations of 5 or more and high frequency of operation should be used with AMC810-14. Exhaust cleaners AMC610-10 and AMC810-14 are not attached.



### How to Order

**VVFS4 - 10 - 06 1 - 03 - CD -**

VFS4000 Series Manifold

**Base type/Electrical entry**

01T	Plug-in type with terminal block
01C	Plug-in type with multi-connector
01F	Plug-in type with D-sub connector
10	Non plug-in type

**Connector mounting direction**

Symbol	With connector	Applicable base
Nll	None	01T, 10
D	D side mounting	01C, 01F
U	U side mounting	

**Stations**

02	2 stations
:	:
10	10 stations

Base type 01T, 10: 2 to 10 stations  
Base type 01C, 01F: 2 to 8 stations

**Thread type**

Nll	Rc
N*	NPT
T*	NPTF
F*	G

\* Semi-standard

**Port size**

Symbol	P	A, B
03		3/8
04	1/2	1/2
M		Mixed

\* For bottom ported, 3/8 is only available.

**CE/UKCA-compliant**

Nll	-
Q	CE/UKCA-compliant

**Exhaust cleaner mounting direction**

Symbol	Exhaust cleaner mounting direction
CD	D side   D side mounting
CU	U side   U side mounting

\* Please indicate exhaust cleaner size or port size.

**Symbol**

Symbol	Passage		Porting specifications (A, B)
	P	R1, R2	
1	Common	Common	Side
2			Bottom*

\* Semi-standard

### ⚠ Caution

When using an exhaust cleaner, mount it downwards.

\* Refer to Best Pneumatics No. 7 for Exhaust Cleaner details.

### How to Order Manifold Assembly [Example]

Add the valve and option part numbers in order starting from the first station on the D side.

<Example>

- Plug-in type with terminal block (6 stations)
  - (Manifold base) **VVFS4-01T-061-03-CD** ..... 1
  - (2 position single) \* **VFS4110-5FZ** ..... 3
  - (2 position double) \* **VFS4200-5FZ** ..... 2
  - (Blanking plate) \* **VVFS4000-10A** ..... 1
  - (Exhaust cleaner) **AMC610-10** ..... 1
- Non plug-in type (6 stations)
  - (Manifold base) **VVFS4-10-061-04-CU** ..... 1
  - (2 position single) \* **VFS4110-5E** ..... 3
  - (2 position double) \* **VFS4210-5E** ..... 2
  - (Blanking plate) \* **VVFS4000-10A** ..... 1
  - (Exhaust cleaner) **AMC810-14** ..... 1

The asterisk denotes the symbol for assembly. Prefix it to the part numbers of the solenoid valve.

SV  
SYJ  
SZ  
VF  
VP4  
VQ 1/2  
VQ 4/5  
VQC 1/2  
VQC 4/5  
VQZ  
SQ  
VFS  
VFR  
VQ7

# VFS4000 Series

## Manifold with Exhaust Cleaner — Plug-in type, Non plug-in type

Plug-in type: VV5FS4-01T-Station 1-Port size- $\frac{CD}{CU}$

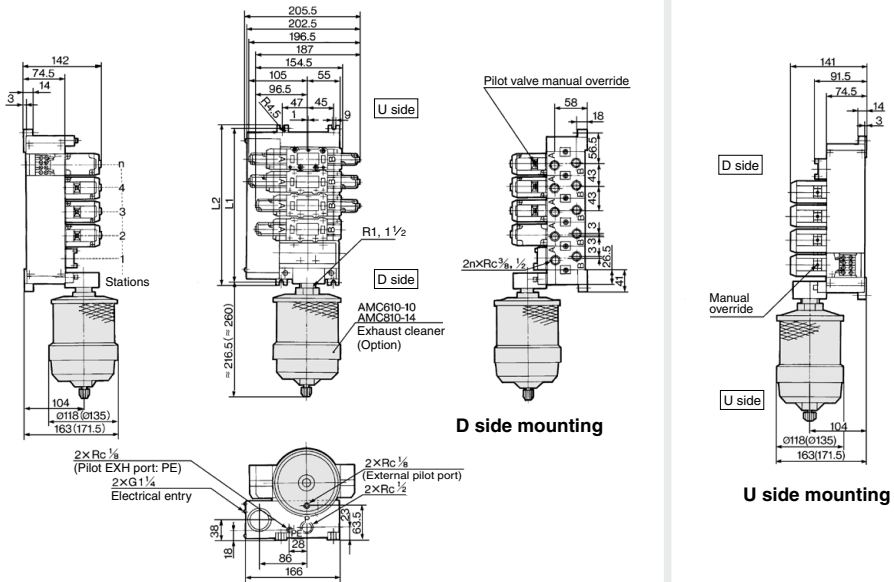

( ): AMC810

Non plug-in type: VV5FS4-10-Station 1-Port size- $\frac{CD}{CU}$

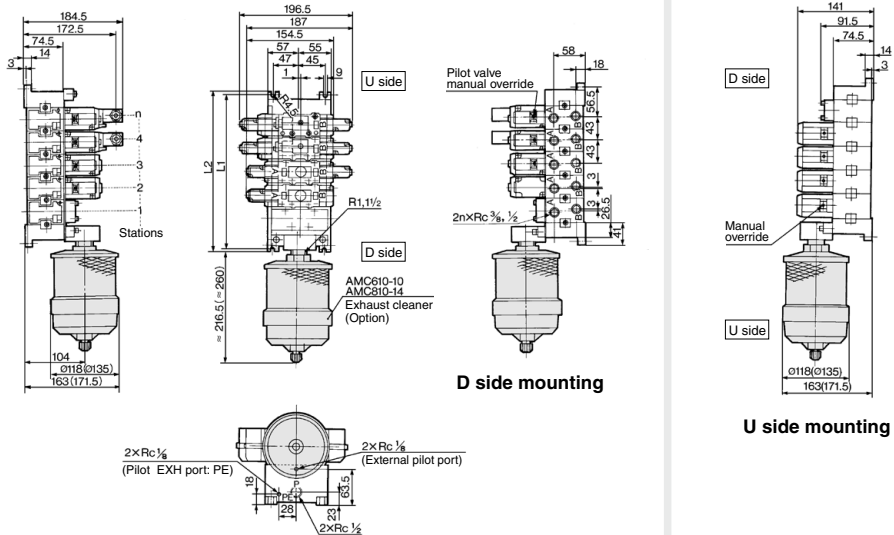

( ): AMC810

Station	2	3	4	5	6	7	8	9	10	Formula
L <sub>1</sub>	156	199	242	285	328	371	414	457	500	L <sub>1</sub> = 43 x n + 70
L <sub>2</sub>	168	211	254	297	340	383	426	469	512	L <sub>2</sub> = 43 x n + 82

# Manifold with Control Unit

- Control unit (Filter, Regulator, Pressure switch, Air release valve) are all standardized to the one unit, and can be mounted on the manifold base without any attachments.
- Piping processes are eliminated.

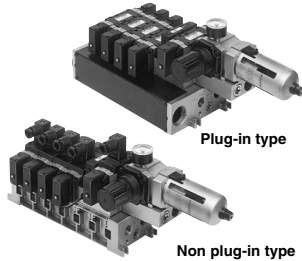

## Manifold Specifications

Manifold	Plug-in type: VV5FS4-01□	Non plug-in type: VV5FS4-10
Wiring	With terminal block With multi-connector With D-sub connector	DIN terminal Grommet terminal
Applicable valve model	VFS4□00-□F	VFS4□10-□D, VFS4□10-□E
Porting specifications Rc (PT)	Common SUP, Common EXH	
	2(B), 4(A) port	Side: 3/8, 1/2, Bottom: 3/8
Stations	1(P), 3(R2), 5(R1) port	Side: 1/2
	2 to 10 <sup>(1)</sup>	

Note 1) With multi-connector, or with D-sub connector: 8 stations max.

## Control Unit Specifications

Air filter (With auto-drain/With manual drain)	
Filteration degree	5 μm
Regulator	
Set pressure (Outlet pressure)	0.05 to 0.85 MPa
Pressure switch <sup>(1)</sup>	
Set pressure range: OFF	0.1 to 0.6 MPa
Differential	0.08 MPa or less
Contact	1a
Indicator light	LED (RED)
Max. switch capacity	2 VA AC, 2 W DC
Max. operating current	24 VAC/DC or less: 50 mA
	48 VAC/DC: 40 mA 100 VAC/DC: 20 mA
Air release valve (Single only)	
Operating pressure range	0.1 to 1.0 MPa

## Control Unit/Option

Air release valve spacer <sup>(2)</sup>	<Plug-in type>	VVFS4000-24A-1R (D side mounting)
	<Non plug-in type>	VVFS4000-24A-2R (D side mounting)
Pressure switch	IS100P-2-1	
Blanking plate <sup>(3)</sup>	Filter regulator	MP2-3
	Pressure switch	MP3-2
	Release valve	VVFS4000-24A-10
Filter element	11104-5B	
Regulator with filter	Manually operated	INA-13-864G
	Auto-drain type	INA-13-864DG

Note 1) Voltage: 24 VDC to 100 VAC  
Inner voltage drop: 4 V

Note 2) Combination of a valve VFS4□□ (single) and a release valve spacer can be used as an air release valve.

Note 3) The non plug-in type cannot be mounted afterwards.

## Caution

When using an air filter with auto-drain or manual drain, mount the filter vertically.



## How to Order

**VV5FS4 - 01C D - 08 1 - 03 - AP - - -** → CE/UKCA-compliant

**VFS4000 Series Manifold**

**Base type/Electrical entry**

01T	Plug-in type with terminal block
01C	Plug-in type with multi-connector
01F	Plug-in type with D-sub connector
10	Non plug-in type

**Connector mounting direction**

Symbol	With connector	Applicable base
NII	None	01T, 10
D	D side mounting	01C, 01F
U	U side mounting	

**Stations**

02	2 stations
:	:
10*	10 stations

\* Base type 01T, 10: 2 to 10 stations  
Base type 01C, 01F: 2 to 8 stations

**Symbol**

Symbol	Passage		Porting specifications (A, B)
	P	R1, R2	
1	Common	Common	Side
2			Bottom*

\* Semi-standard

**Port size**

Symbol	P, R1, R2	A, B
03		3/8
04	1/2	1/2
M		Mixed

\* For bottom ported, 3/8 is only available.

**Thread type**

NII	Rc
N <sup>ø</sup>	NPT
T <sup>ø</sup>	NPTF
F <sup>ø</sup>	G

\* Semi-standard

**Air release valve coiling rating**

NII	None (F, G type only)
1	100 VAC, 50/60 Hz
5	24 VDC

For other rated voltages, please consult with SMC.

**Control unit type**

Symbol	NII	A	AP	M	MP	F	G	C	E
Control equipment									
Air filter with auto-drain		●	●			●			
Air filter with manual drain				●	●		●		
Regulator		●	●	●	●	●	●		
Air release valve		●						●	●
Pressure switch			●		●				
Blanking plate (Air release valve)							●	●	
Blanking plate (Filter, Regulator)								●	
Blanking plate (Pressure switch)	●		●			●	●	●	
Number of manifold blocks required for mounting (stations)	2	2	2	2	2	2	2	2	1

## How to Order Manifold Assembly [Example]

Add the valve and option part numbers in order starting from the first station on the D side.

### <Example>

- Plug-in type with terminal block: In order to mount control unit, it requires 2 stations.  
(Manifold base) VV5FS4-01T-081-03-AP5 ..... 1  
(2 position single) \* VFS4100-5FZ ..... 4  
(2 position double) \* VFS4200-5FZ ..... 2
- Non plug-in type: In order to mount control unit, it requires 2 stations.  
(Manifold base) VV5FS4-10-061-03-A ..... 1  
(2 position single) \* VFS4110-5D ..... 4

The asterisk denotes the symbol for assembly. Prefix it to the part numbers of the solenoid valve.

# VFS4000 Series

## Manifold with Control Unit — Plug-in type, Non plug-in type

Plug-in type: VVFS4-01T-Station 1-Port size-AP Voltage for release valve

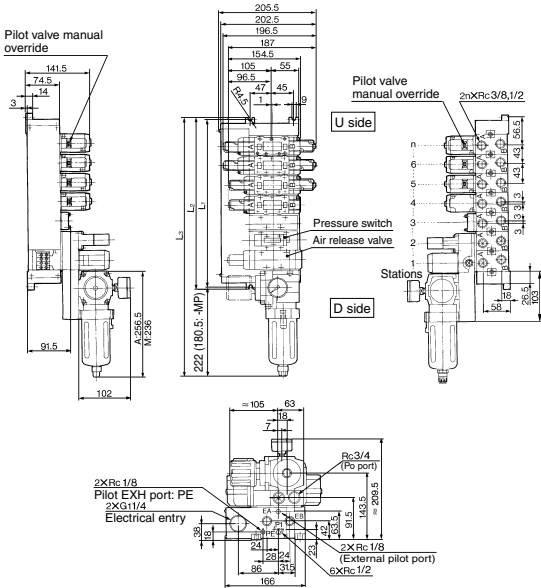

### Example for manifold

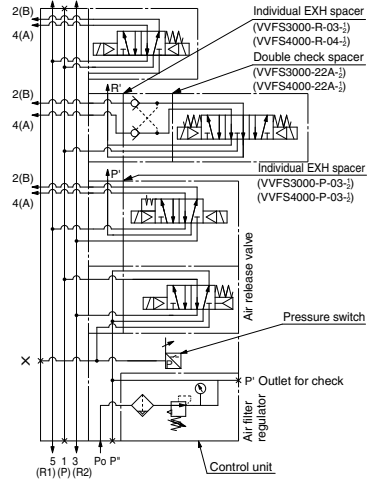

Non plug-in type: VVFS4-10-Station 1-Port size-AP Voltage for release valve

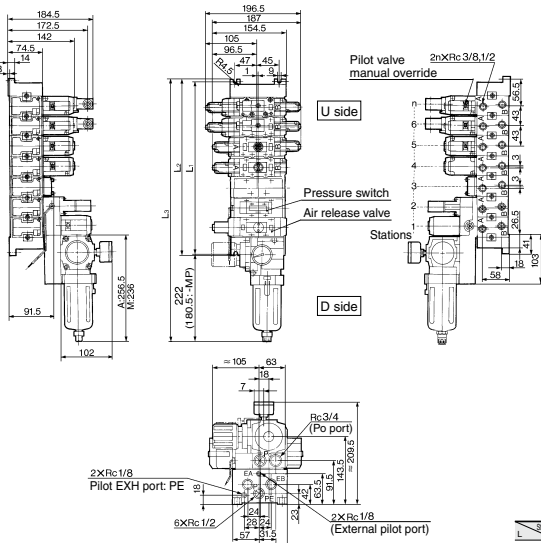

### Example for manifold

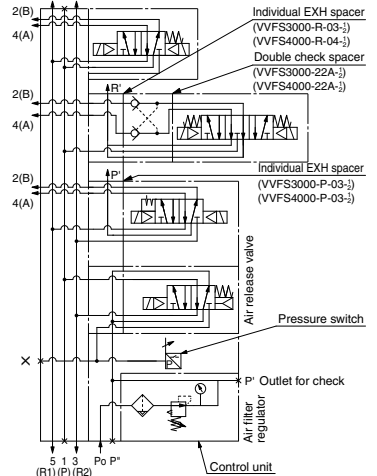

		n: Stations								Formula
Station		3	4	5	6	7	8	9	10	
L1		199	242	285	328	371	414	457	500	$L1 = 43 \times n + 70$
L2		211	254	297	340	383	426	469	512	$L2 = 43 \times n + 82$
L3 (MP)		385.5	428.5	471.5	514.5	557.5	600.5	643.5	686.5	$L3 = 43 \times n + 256.5$
L3 (AP)		427	470	513	556	599	642	685	728	$L3 = 43 \times n + 298$

<b>SV</b>
<b>SYJ</b>
<b>SZ</b>
<b>VF</b>
<b>VP4</b>
VQ 1/2
VQ 4/5
VQC 1/2
VQC 4/5
<b>VQZ</b>
<b>SQ</b>
<b>VFS</b>
<b>VFR</b>
<b>VQ7</b>

# VFS4000 Series Made to Order

Serial Transmission Kit Manifold: EX123/124 Integrated Type (For Output)  
Serial Transmission System



## How to Order

### How to Order Manifold

VV5FS4 - 01S U V - 08 1 - 03 [ ] - X199

Plug-in type  
Serial transmission kit

SI unit mounting position

D	D side mounting
U	U side mounting

Stations

02	2 stations
:	:
10	10 stations

Thread type

Nil	Rc
N	NPT
T	NPTF
F	G

Port size

Symbol	P, R1, R2	A, B
03		3/8
04	1/2	1/2
M		Mixed

\* For bottom ported: 3/8 only

Note 1) Max. 10 stations. Add 1 station for serial unit mounting.  
Note 2) Max. 10 Stations: For single and double mixed wiring. (No. of valves: 9)  
Max. 9 stations: For standard double wiring (No. of valves: 8)

SI unit can be mounted on either U or D side.

Combination symbol

Symbol	Port specification		Piping specification A, B
	P	R1, R2	
1	Common	Common	Side
2*			Bottom

\* Semi-standard

Applicable models

Symbol	SI unit part no.		Description
	For U side mounting	For D side mounting	
0	—	—	Without SI unit
H	EX123U-SUH1	EX123D-SUH1	NKE Corporation: Fieldbus H System (16 outputs)
Q	EX124U-SDN1	EX124D-SDN1	DevieNet (2 power supply systems)
R1	EX124U-SCS1	EX124D-SCS1	OMRON Corporation: CompoBus/S (16 outputs) (2 power supply systems)
R2	EX124U-SCS2	EX124D-SCS2	OMRON Corporation: CompoBus/S (8 outputs) (2 power supply systems)
V	EX124U-SMJ1	EX124D-SMJ1	CC-Link (2 power supply systems)

Refer to Best Pneumatics No. 1-1 and the Operation Manual for the details of EX123/124 Integrated-type (For Output) Serial Transmission System. Please download the Operation Manual via our website, <http://www.smcworld.com>

### Correspondence of SI unit output numbers and solenoid valve coils

<Wiring Example 1> Double wiring (Standard)

D side

U side

SI unit output no.	1	2	3	4	5	6	7	8	9
	Double	Double	Single	Single	Single	Double	Single	Single	SI unit
	AB	AB	AB	AB	AB	AB	AB	AB	

01 23 45 67 89 1011 1213 1415

<Wiring Example 2> Single/Double mixed wiring (Semi-standard)

D side

U side

SI unit output no.	1	2	3	4	5	6	7	8	9	10
	Double	Double	Single	Single	Single	Double	Single	Double	Single	SI unit
	AB	AB	A	A	A	AB	A	AB	A	

01 23 4 5 6 78 9 1011 11

\* Mixed wiring is available as a semi-standard. Use the manifold specification sheet to specify this.

### How to Order Valves

VFS4 [ ] 00 [ ] - 5 F [ ] [ ]

Symbol

1	2 position single
2	2 position double
3	3 position closed center
4	3 position exhaust center
5	3 position pressure center
6	3 position double check

Pilot type

Nil	Internal pilot
R	External pilot

24 VDC

Pilot valve manual override

Nil	Non-locking push type (Flush)
A	Non-locking push type (Extended)
B	Locking type (Tool required)
C	Locking type (Lever)

Option

Nil	None
Z	With light/surge voltage suppressor

Coil rated voltage

Nil	None
-----	------



# 5 Port Pilot Operated Solenoid Valve Metal Seal, Plug-in/Non Plug-in **VFS4000 Series**

## Serial Transmission Kit Manifold (EX123/124): Plug-in Type

VV5FS4-01S **Mounting position** | **Model** | **Stations** | **Symbol** | **Port size** | **Thread** | **X199**

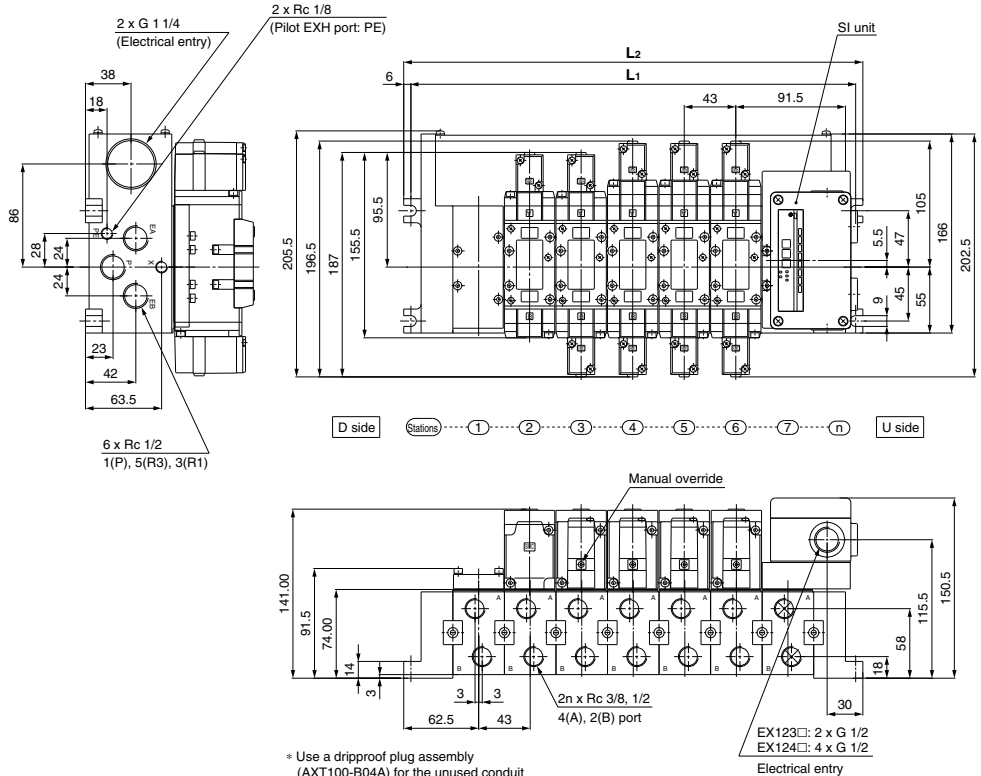

\* Use a dripproof plug assembly (AXT100-B04A) for the unused conduit port (G 1/2).

### Dimensions

Formula  $L_1 = 43n + 70$   $L_2 = 43n + 82$   
n: Stations (Max. 10 stations)

n	2	3	4	5	6	7	8	9	10
$L_1$	156	199	242	285	328	371	414	457	500
$L_2$	168	211	254	297	340	383	426	469	512

Note) Actual number of manifold base stations: Add 1 SI unit mounting station to the number of valve stations.

- SV
- SYJ
- SZ
- VF
- VP4
- VQ 1/2
- VQ 4/5
- VQC 1/2
- VQC 4/5
- VQZ
- SQ
- VFS
- VFR
- VQ7

# VFS4000 Series

## Manifold Option Parts — Plug-in type, Non plug-in type

**Individual SUP spacer:**  
**VVFS4000-P-03-1 (Plug-in type)**  
**VVFS4000-P-03-2 (Non plug-in type)**

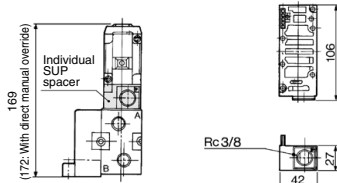

**Double check spacer:**  
**VVFS4000-22A-1 (Plug-in type)**  
**VVFS4000-22A-2 (Non plug-in type)**

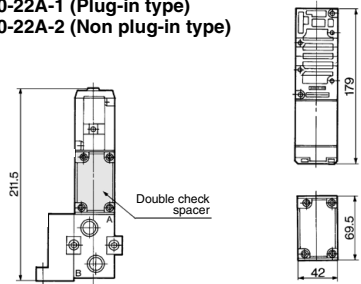

**Individual EXH spacer:**  
**VVFS4000-R-04-1 (Plug-in type)**  
**VVFS4000-R-04-2 (Non plug-in type)**

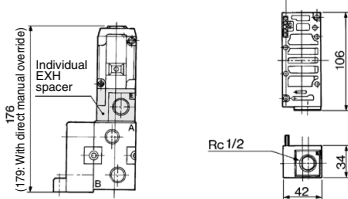

**Interface regulator/P port regulation:**  
**ARBF4050-00-P-1 (Plug-in type)**  
**ARBF4050-00-P-2 (Non plug-in type)**

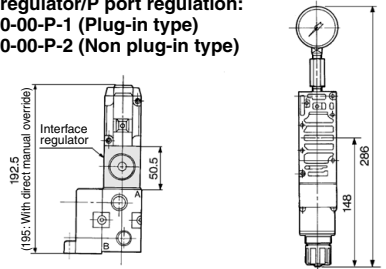

**SUP block plate: AXT634-10A**  
**EXH block plate: AXT634-11A**

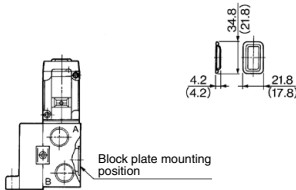

( ): EXH block plate

**Interface regulator/A port regulation:**  
**ARBF4050-00-A-1 (Plug-in type)**  
**ARBF4050-00-A-2 (Non plug-in type)**

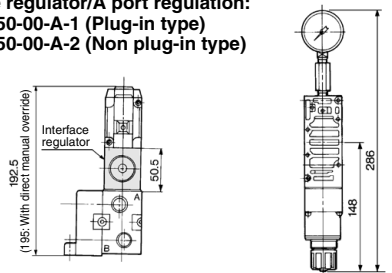

**Throttle valve spacer:**  
**VVFS4000-20A-1 (Plug-in type)**  
**VVFS4000-20A-2 (Non plug-in type)**

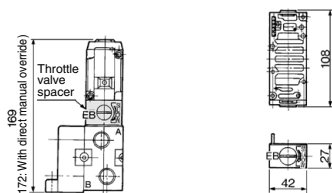

**Interface regulator/B port regulation:**  
**ARBF4050-00-B-1 (Plug-in type)**  
**ARBF4050-00-B-2 (Non plug-in type)**

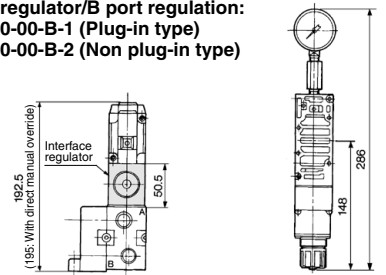

**Manifold Base Construction — Plug-in type, Non Plug-in type**

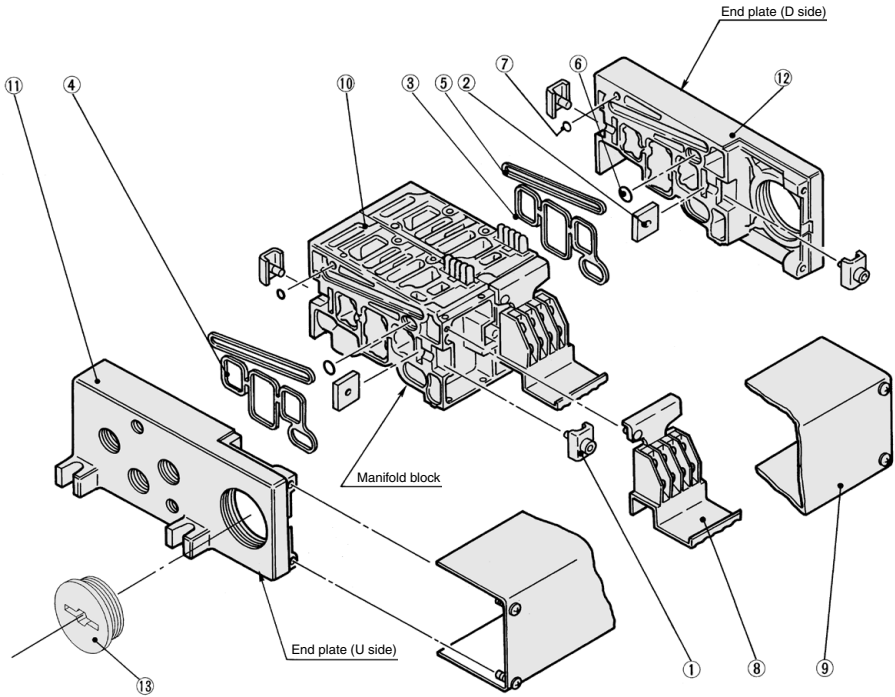

SV
SYJ
SZ
VF
VP4
VQ 1/2
VQ 4/5
VQC 1/2
VQC 4/5
VQZ
SQ
<b>VFS</b>
VFR
VQ7

**Replacement Parts**

No.	Description	Material	Part no.
1	Connection fitting A	Steel plate	VVF4000-5-1A
2	Connection fitting B	Steel plate	VVF4000-5-2
3	Gasket	NBR	VVF4000-7 (End plate)
4	Gasket	NBR	VVF4000-7-1 (Manifold block)
5	Gasket	NBR	VVF4000-8
6	O-ring	NBR	KA00407
7	O-ring	NBR	KA00078
8	Terminal assembly	—	VVF4000-6A
9	Junction cover assembly	For 01T For 01S□	VVF4000-4A- <small>[Stations]</small> AZ738-30A- <small>[Stations]</small> D
13	Rubber plug	NBR	AXT336-9

- For increasing the manifold bases, please order the manifold block assembly number of the principal part assembly 10. For plug-in type: The manifold base with terminal stand (integrated with a junction cover) is required with the 9 junction cover assembly.

\* D : For mounting the D side of the SI unit, U : For mounting the U side of the SI unit

**Replacement Parts: Sub Assembly**

Note) Manifold Base/Construction: Plug-in type with terminal block.

No.	Description	Assembly part no.	Component parts	Applicable manifold base
10	Manifold block assembly	VVF4000-1A-1- <small>03</small> <small>04</small>	Manifold block 10, Terminal 8, Metal joint 1, 2, Gasket 3, Receptacle assembly	Plug-in type
		VVF4000-1A-2- <small>03</small> <small>04</small>	Manifold block 10, Metal joint 1, 2, Gasket 4	Non plug-in type
11	End plate (U side) assembly	VVF4000-2A-1	End plate (U) 11, Metal joint 1, 2	Plug-in type
		VVF4000-2A-2	End plate (U) 11, Metal joint 1, 2	Non plug-in type
12	End plate (D side) assembly	VVF4000-3A-1	End plate (D) 12, Metal joint 1, 2, Gasket 3, 5, O-ring 6, 7	Plug-in type
		VVF4000-3A-2	End plate (D) 12, Metal joint 1, 2, Gasket 3, 5, O-ring 5, 6	Non plug-in type

# 5 Port Pilot Operated Solenoid Valve Metal Seal, Plug-in/Non Plug-in

## VFS5000 Series



● VFS5000 series is compatible with the old models, VF6□00 and VF6□10 series.

(Details → P. 1007)

### Model

Type of actuation		Model		Flow rate characteristics						Max. <sup>(1)</sup> operating cycle (cpm)	Response time <sup>(2)</sup> (ms)	Weight <sup>(3)</sup> (kg)	
				1 → 4/2 (P → A/B)			4/2 → 5/3 (A/B → R1/R2)						
				C [dm <sup>3</sup> /(s·bar)]	b	Cv	C [dm <sup>3</sup> /(s·bar)]	b	Cv				
2 position	Single	VFS5100	VFS5110	3/8	15	0.30	3.7	15	0.30	4.1	600	45 or less	0.88
				1/2	16	0.15	3.7	19	0.15	4.5			
				3/4	17	0.15	3.9	20	0.13	4.7			
	Double	VFS5200	VFS5210	3/8	15	0.30	3.7	15	0.30	4.1			
				1/2	16	0.15	3.7	19	0.15	4.5			
				3/4	17	0.15	3.9	20	0.13	4.7			
3 position	Closed center	VFS5300	VFS5310	3/8	14	0.25	4.0	14	0.24	4.1	300	55 or less	1.16
				1/2	16	0.25	4.1	16	0.24	4.1			
				3/4	16	0.25	4.1	16	0.23	4.1			
				3/8	14	0.32	3.8	14	0.25	3.5			
				1/2	16	0.17	3.8	16	0.18	4.1			
				3/4	17	0.20	4.2	17	0.13	4.1			
	Exhaust center	VFS5400	VFS5410	3/8	14	0.30	3.7	14	0.31	3.8	300	55 or less	1.14
				1/2	16	0.23	3.9	16	0.22	4.1			
				3/4	18	0.25	4.6	17	0.22	4.3			
	Pressure center	VFS5500	VFS5510	3/8	9.0	—	—	9.0	—	—	300	55 or less	1.14
				1/2	9.0	—	—	9.0	—	—			
				3/4	9.0	—	—	9.0	—	—			
Double check	VFS5600	VFS5610	3/8	9.0	—	—	9.0	—	—	180	60 or less	1.99	
			1/2	9.0	—	—	9.0	—	—				
			3/4	9.0	—	—	9.0	—	—				

Note 1) Based on JIS B 8419: 2010 (once per 30 days) for the minimum operating frequency.

Note 2) Based on JIS B 8419:2010. (The value at supply pressure 0.5 MPa, ambient fluid temperature (-20°C))

However, this excludes when in an adhered state. (Be aware that after long periods of holding time, there may be delays in the initial response time.)

Note 3) The figures in the above list are without sub-plate. In the case of with plug-in sub-plate and, with non plug-in sub-plate add Rc 3/8, 1/2—0.744 kg, Rc 3/4—0.966 kg and Rc 3/8, 1/2—0.577 kg, Rc 3/4—0.823 kg respectively.

Note 4) \*Note 1) and \*Note 2) are with controlled clean air.

Compact yet provides a large flow capacity  
3/4: C: 20 dm<sup>3</sup>/(s·bar)

Low power consumption: 1.8 W DC

Easy maintenance

2 types of sub-plates:  
Plug-in and non plug-in

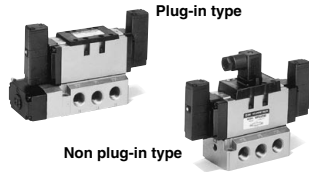

### Symbol

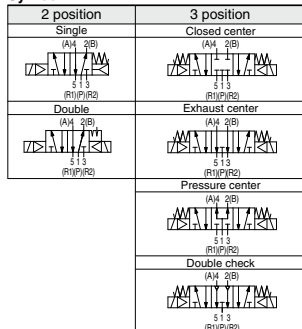

### Standard Specifications

		Fluid	Air	
Valve specifications	Maximum operating pressure	1.0 MPa		
	Minimum operating pressure	0.1 MPa		
	Proof pressure	1.5 MPa		
	Ambient and fluid temperature	-10 to 60°C <sup>(1)</sup>		
	Lubrication	Non-lube <sup>(2)</sup>		
	Pilot valve manual override	Non-locking push type (Flush)		
	Impact/Vibration resistance	150/50 m/s <sup>2</sup> <sup>(3)</sup>		
Electricity specifications	Enclosure	Type E: Dustproof (Equivalent to IP50), Type F: Dripproof (Equivalent to IP52), Type D: Splashproof (Equivalent to IP54) <sup>(4) (5)</sup>		
	Coil rated voltage	100, 200 VAC, 50/60 Hz; 24 VDC		
	Allowable voltage fluctuation	-15 to +10% of rated voltage		
	Coil insulation type	Class B or equivalent (130°C) <sup>(6)</sup>		
	Apparent power (Power consumption) AC	Inrush	5.6 VA/50 Hz, 5.0 VA/60 Hz	
	Power consumption DC	Holding	3.4 VA (2.1 W)/50 Hz, 2.3 VA (1.5 W)/60 Hz	
			1.8 W (2.04 W: With light/surge voltage suppressor)	
Electrical entry	Plug-in type	Conduit terminal		
	Non plug-in type	Grommet terminal, DIN terminal		

Note 1) Use dry air at low temperatures. Note 2) Use turbine oil Class 1 (ISO VG32), if lubricated.

Note 3) Impact resistance: No malfunction occurred when it is tested with a drop tester in the axial direction and at the right angles to the main valve and armature in both energized and de-energized states every once for each condition. (Values at the initial period)

Vibration resistance: No malfunction occurred in a one-sweep test between 45 and 2000 Hz. Test was performed at both energized and de-energized states in the axial direction and at the right angles to the main valve and armature. (Values at the initial period)

Note 4) Based on JIS C 0920. Note 5) Based on JIS C 4003.

Note 6) The F type enclosure described above shows that without the light/surge voltage suppressor. The F type enclosure with the light/surge voltage suppressor is equivalent to IP50.

### Option Specifications

Pilot type		External pilot <sup>Note)</sup>
Manual override	Main valve	Direct manual override
	Pilot valve	Non-locking push type (Extended), Locking type (Tool required), Locking type (Lever)
Coil rated voltage		110 to 120, 220, 240 VAC (50/60 Hz) 12, 100 VDC
Porting specifications		Bottom ported
Option		With light/surge voltage suppressor

Note) Operating pressure: 0 to 1.0 MPa

Pilot pressure: 0.1 to 1.0 MPa



# 5 Port Pilot Operated Solenoid Valve Metal Seal, Plug-in/Non Plug-in **VFS5000 Series**



## How to Order

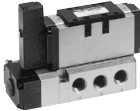

**Plug-in**



**Non plug-in**

**Body type**

**O:** Plug-in type sub-plate

**F:** Plug-in type conduit terminal

**Electrical entry**

**Porting specifications**

Nil	Side ported
B*	Bottom ported

\* In the case of external pilot (Semi-standard), bottom piping is not available.

**Port size**

Nil	Without sub-plate
03	3/8
04	1/2
06	3/4 /

**Thread type**

Nil	Rc
N*	NPT
T*	NPTF
F*	G

\* Semi-standard

**CE/UKCA-compliant**

Nil	—
Q	CE/UKCA-compliant

**Ordering Code**

**Plug-in:** VFS5 1 0 0 - 2 F - - 04 - -

**Non plug-in:** VFS5 1 1 0 - 5 D - - 06 - -

**Option**

Nil	None
Z	With light/surge voltage suppressor

**Electrical entry**

E:	Grommet terminal
D:	DIN terminal without connector

**Symbol**

1 2 position single (A)4 (B)2 5 1 3 (R1)(P1)(R2)	5 3 position pressure center (A)4 (B)2 5 1 3 (R1)(P1)(R2)
2 2 position double (A)4 (B)2 5 1 3 (R1)(P1)(R2)	6 3 position double check (A)4 (B)2 5 1 3 (R1)(P1)(R2)
3 3 position closed center (A)4 (B)2 5 1 3 (R1)(P1)(R2)	
4 3 position exhaust center (A)4 (B)2 5 1 3 (R1)(P1)(R2)	

**Body type**

1: Non plug-in type sub-plate

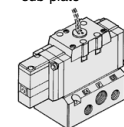

**Coil rated voltage**

1	100 VAC, 50/60 Hz
2	200 VAC, 50/60 Hz
3*	110 to 120 VAC, 50/60 Hz
4*	220 VAC, 50/60 Hz
5	24 VDC
6*	12 VDC
7*	240 VAC, 50/60 Hz

\* Semi-standard  
For other rated voltages, please consult with SMC.

**Pilot type**

Nil	Internal pilot
R*	External pilot

\* Semi-standard

**Pilot valve Manual override**

Nil:	Non-locking push type (Flush)
A*:	Non-locking push type (Extended)
B*:	Locking type (Tool required)
C*:	Locking type (Lever)

\* Semi-standard

SV
SYJ
SZ
VF
VP4
VQ 1/2
VQ 4/5
VQC 1/2
VQC 4/5
VQZ
SQ
VFS
VFR
VQ7

## How to Order Pilot Valve Assembly

Ordering Code: SF4 - 1 F - 30

Coil rated voltage	Manual override
1	Nil
2	Non-locking push type (Flush)
3*	A*
4*	Non-locking push type (Extended)
5	B*
6*	Locking type (Tool required)
7*	C*
	Locking type (Lever)

\* Semi-standard  
For other rated voltages, please consult with SMC.  
\*\* Refer to page 1010 for voltage conversion.

\* Semi-standard

# VFS5000 Series

## Cylinder Speed Chart

Use as a guide for selection.  
Please confirm the actual conditions with SMC Sizing Program.

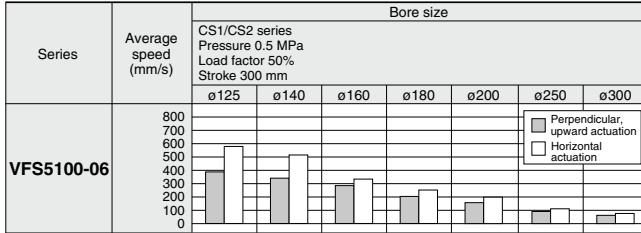

- \* It is when the cylinder is extending that is meter-out controlled by speed controller which is directly connected with cylinder, and its needle valve with being fully open.
- \* The average velocity of the cylinder is what the stroke is divided by the total stroke time.
- \* Load factor: ((Load mass x 9.8)/Theoretical force) x 100%

## Conditions

		CS1 series
VFS5100-06	Tube bore x Length	SGP20A x 1 m
	Speed controller	AS500-06
	Silencer	AN500-06

## Double Check Spacer/Specifications

### Can hold an intermediate cylinder position for an extended time

If the double check spacer with a built-in double check valve is combined, it will enable the cylinder to stop in the intermediate stroke and maintain its position for a long time without being affected by the leakage between the spools.

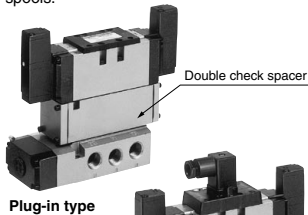

Plug-in type

Non plug-in type

### Specifications

Double check spacer part no.	Plug-in type	Non plug-in type
	VVFS5000-22A-1	VVFS5000-22A-2
Applicable valve model	VFS5400-□F	VFS5410-□D VFS5410-□E

### ⚠ Caution

- In the case of 3 position double check valve (VFS56□0), check the leakage from piping and fittings in between valve and cylinder by means of synthetic detergent solutions, and ensure that there is no such leakage found there. Also check the leakage from cylinder seal and piston seal. If there is any leakage, sometimes the cylinder, when valve is de-energized, can move without stopping at intermediate position.
- Be aware that if the exhaust side is restricted excessively, the intermediate stopping accuracy will decrease and will lead to improper intermediate stops.

### Check Valve Operation

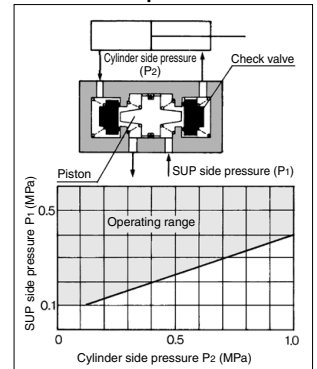

- The combination of VFS51□0, VFS52□0 and a double check spacer can be used as prevention of falling at the stroke end but cannot hold the intermediate position of the cylinder.

# 5 Port Pilot Operated Solenoid Valve Metal Seal, Plug-in/Non Plug-in **VFS5000 Series**

## Construction

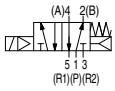

**2 position single**

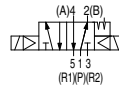

**2 position double**

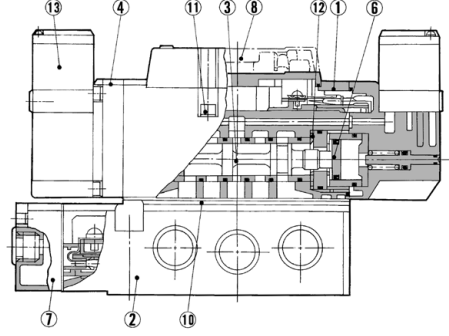
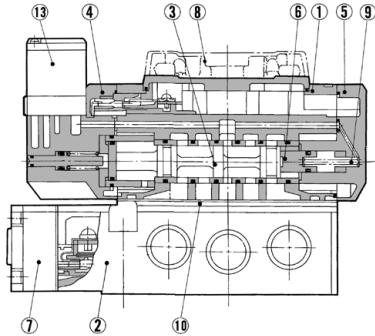

**3 position closed center/exhaust center/pressure center**

**Closed center**

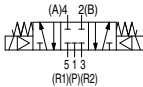

**Exhaust center**

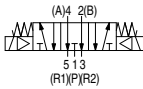

**Pressure center**

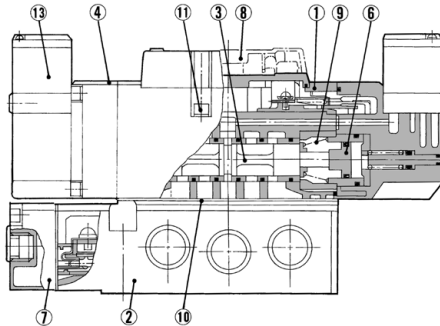

### Component Parts

No.	Description	Material	Note
1	Body	Aluminum die-casted	—
2	Sub-plate	Aluminum die-casted	—
3	Spool/Sleeve	Stainless steel	—
4	Adapter plate	Resin	—
5	End plate	Resin	—
6	Piston	Resin	—
7	Junction cover	Resin	—
8	Light cover	Resin	—
9	Return spring	Stainless steel	—
10	Gasket	NBR	—
11	Hexagon socket head screw	Steel	—
12	Detent assembly	—	—
13	Pilot valve assembly	—	—

\* Refer to "How to Order Pilot Valve Assembly" on page 983.

### Sub-plate Assembly Part No.

Plug-in	VFS5000-P- $\frac{3}{16}$ (N, T, F)
Non plug-in	VFS5000-S- $\frac{3}{16}$ (N, T, F)

\* Mounting bolt and gasket are not included.

### Sub-plate Assembly (For External Pilot) Part No.

Plug-in	VFS5000-P-R- $\frac{3}{16}$ (N, T, F)
	VFS5000-S-R- $\frac{3}{16}$ (N, T, F)

Part no. for mounting bolt and gasket	Note	
BG-VFS5000	Plate gasket type (Earlier than August, 2012) <sup>Note</sup>	
BG-VFS5000-1	Groove gasket type (After September 2012) <sup>Note</sup>	

Note) When ordering the parts shown above for the replacement, note that the described date may slightly vary depending on the product being used.

SV
SYJ
SZ
VF
VP4
VQ 1/2
VQ 4/5
VQC 1/2
VQC 4/5
VQZ
SQ
VFS
VFR
VQ7

# VFS5000 Series

## Plug-in — 2 Position single/Double/3 Position closed center/Exhaust center/Pressure center/Double check

### 2 position single: VFS5100-□F(Z)

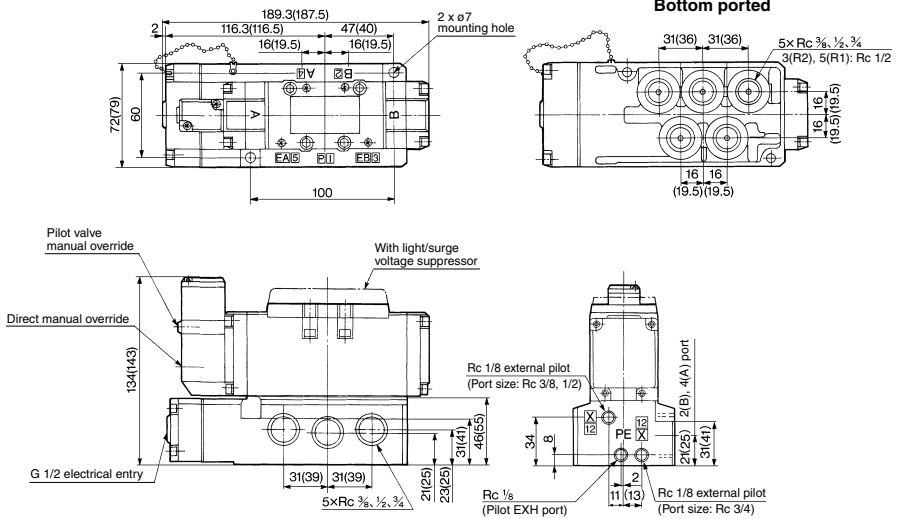

( ): Rc 3/4

### 2 position double: VFS5200-□F(Z)

### 3 position closed center: VFS5300-□F(Z)

### 3 position exhaust center: VFS5400-□F(Z)

### 3 position pressure center: VFS5500-□F(Z)

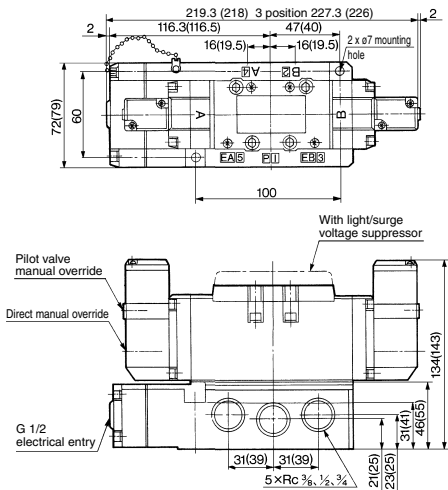

( ): Rc 3/4

### 3 position double check: VFS5600-□F(Z)

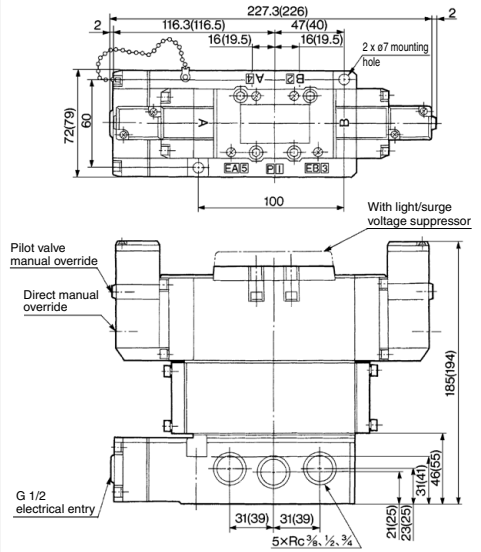

( ): Rc 3/4





# VFS5000 Series Manifold Specifications



## Plug-in Type: With Terminal Block

- Since lead wires of solenoid valve are connected with the terminals on upper surface of terminal block, corresponding lead wires from power source can be wired at the bottom of terminal block.

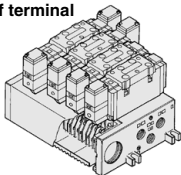

**VV5FS5-01T-06 1-04**

VFS5000 Series Manifold  
Plug-in type with terminal block

**Stations**

02	2 stations
⋮	⋮
10	10 stations

**CE/UKCA-compliant**

Nil	—
Q	CE/UKCA-compliant

**Port size**

Symbol	P, R1, R2	A, B
04	—	1/2
06	3/4	3/4
M	—	Mixed

**Thread type**

Nil	Rc
N*	NPT
T*	NPTF
F*	G

\* Semi-standard

**Symbol**

Symbol	Passage		Porting specifications (A, B)
	P	R1, R2	
1	Common	Common	Side
2	Common	Common	Bottom*

\* Semi-standard

\* For bottom ported, 1/2 is only available.

## Plug-in Type: With Multi-connector (Wiring specifications: Refer to page 1013.)

- Quick wiring permits easier installation.

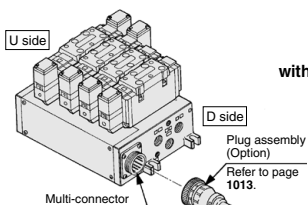

**VV5FS5-01C D-05 2-04**

VFS5000 Series Manifold  
Plug-in type with multi-connector

**Stations**

02	2 stations
⋮	⋮
08*	8 stations

\* Max. 8 stations

**CE/UKCA-compliant**

Nil	—
Q	CE/UKCA-compliant

**Port size**

Symbol	P, R1, R2	A, B
04	—	1/2
06	3/4	3/4
M	—	Mixed

**Thread type**

Nil	Rc
N*	NPT
T*	NPTF
F*	G

\* Semi-standard

**Connector mounting direction**

D	D side mounting
U	U side mounting

**Symbol**

Symbol	Passage		Porting specifications (A, B)
	P	R1, R2	
1	Common	Common	Side
2	Common	Common	Bottom*

\* Semi-standard

\* For bottom ported, 1/2 is only available.

## Plug-in Type: With D-sub Connector (Wiring specifications: Refer to page 1013.)

- Wide range of interchangeability (MIL Spec. D-sub connector terminal 25 pcs attached.)
- Quick wiring permits easier installation.

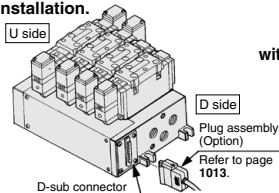

**VV5FS5-01F D-06 1-04**

VFS5000 Series Manifold  
Plug-in type with D-sub connector

**Stations**

02	2 stations
⋮	⋮
08*	8 stations

\* Max. 8 stations

**CE/UKCA-compliant**

Nil	—
Q	CE/UKCA-compliant

**Port size**

Symbol	P, R1, R2	A, B
04	—	1/2
06	3/4	3/4
M	—	Mixed

**Thread type**

Nil	Rc
N*	NPT
T*	NPTF
F*	G

\* Semi-standard

**Connector mounting direction**

D	D side mounting
U	U side mounting

**Symbol**

Symbol	Passage		Porting specifications (A, B)
	P	R1, R2	
1	Common	Common	Side
2	Common	Common	Bottom*

\* Semi-standard

\* For bottom ported, 1/2 is only available.

## Non Plug-in Type: Grommet Terminal, DIN Terminal

- Wiring for every valve.

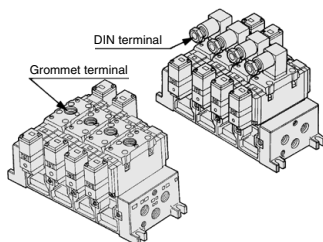

**VV5FS5-10-05 2-04**

VFS5000 Series Manifold  
Non plug-in type

**Stations**

02	2 stations
⋮	⋮
10	10 stations

**CE/UKCA-compliant**

Nil	—
Q	CE/UKCA-compliant

**Port size**

Symbol	P, R1, R2	A, B
04	—	1/2
06	3/4	3/4
M	—	Mixed

**Thread type**

Nil	Rc
N*	NPT
T*	NPTF
F*	G

\* Semi-standard

**Symbol**

Symbol	Passage		Porting specifications (A, B)
	P	R1, R2	
1	Common	Common	Side
2	Common	Common	Bottom*

\* Semi-standard

\* For bottom ported, 1/2 is only available.

# 5 Port Pilot Operated Solenoid Valve Metal Seal, Plug-in/Non Plug-in **VFS5000 Series**

## Manifold Specifications

Base model	Wiring	Porting specifications		Port size Rc		Stations	External pilot	Applicable <sup>(2)</sup> valve model
		A, B port	P, EA, EB	A, B	A, B			
Plug-in type <b>VVFS5-01</b> □	<ul style="list-style-type: none"> <li>With terminal block</li> <li>With multi-connector</li> <li>With D-sub connector</li> </ul>	Side/ Bottom	3/4	1/2, 3/4	2 to 10 <sup>(1)</sup>	Yes <sup>(2)</sup>	VVFS□□□(R)-□□(Z)	
Non plug-in type <b>VVFS5-10</b>	<ul style="list-style-type: none"> <li>DIN terminal</li> <li>Grommet terminal</li> </ul>						VVFS□□□(R)-□□(Z)	

Note 1) With multi-connector, or with D-sub connector: 8 stations max.

Note 2) It is possible to mount the standard valve and the external pilot type valve together.

## How to Order Manifold Assembly

Please indicate manifold base type, corresponding valve, and option parts.

### <Example>

• Plug-in type with terminal block: 6 stations  
(Manifold base) **VVFS5-01T-061-04** ..... 1  
(2 position single) **VFS5100-5FZ** ..... 3  
(2 position double) **VFS5200-5FZ** ..... 2  
(Blanking plate) **VVFS5000-10A** ..... 1

• Non plug-in type: 6 stations  
(Manifold base) **VVFS5-10-061-04** ..... 1  
(2 position single) **VFS5110-5D** ..... 3  
(3 position exhaust center) **VFS5410-5D** ..... 1  
(Individual EXH center) **VVFS5000-R-04-2** ..... 1

## Flow Rate Characteristics at the Number of Manifold Stations (Operated individually)

Model	Passage/Stations	Station 1	Station 5	Station 10	
VVFS5	1 → 4/2 (P → A/B)	C [dm <sup>3</sup> /(s-bar)]	15.0	15.0	15.0
		b	0.20	0.20	0.20
		Cv	4.0	4.0	4.0
	4/2 → 5/3 (A/B → R1/R2)	C [dm <sup>3</sup> /(s-bar)]	16.0	16.0	16.0
		b	0.20	0.20	0.20
		Cv	4.2	4.2	4.2

\* Port size: Rc 1/2, 3/4

## Manifold Option Parts Assembly

### Individual SUP spacer

An individual SUP spacer set on manifold block can form SUP port for every valve.

Body type	Plug-in type	Non plug-in type
Part no.	VVFS5000-P-04-1	VVFS5000-P-04-2

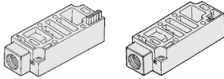

### Individual EXH spacer

An individual EXH spacer set on manifold block can form EXH port for every valve. (common EXH type)

Body type	Plug-in type	Non plug-in type
Part no.	VVFS5000-R-04-1	VVFS5000-R-04-2

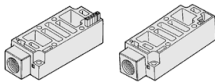

### SUP block plate

When supplying manifold with more than two different pressures, high and low, insert a block plate in between stations subjected to different pressures.

Body type	Plug-in type	Non plug-in type
Part no.	AXT628-12A	

### EXH block plate

When valve exhaust affects the other stations on the circuit or when a reverse pressure valve is used on a standard manifold valve, insert EXH block plate in between stations to separate valve exhaust.

Body type	Plug-in type	Non plug-in type
Part no.	AXT512-14-1A	



EXH block plate



SUP block plate

### Throttle valve spacer

Needle valve set on the manifold block can control cylinder speed by throttling exhaust.

Body type	Plug-in type	Non plug-in type
Part no.	VVFS5000-20A-1	VVFS5000-20A-2

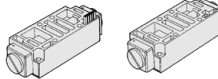

### Double check spacer

If the double check spacer with a built-in double check valve is combined, it will enable the cylinder to stop in the intermediate stroke and maintain its position for a long time without being affected by the leakage between the spools.

Body type	Plug-in type	Non plug-in type
Part no.	VVFS5000-22A-1	VVFS5000-22A-2

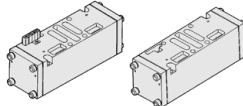

### Interface regulator

Interface regulator set on manifold block can regulate the pressure to each valve. (In the event of using, refer to "Flow Rate Characteristics" on page 1011).

Body type	Plug-in type	Non plug-in type
P port regulation	ARBF5050-00-P-1	ARBF5050-00-P-2
A port regulation	ARBF5050-00-A-1	ARBF5050-00-A-2
B port regulation	ARBF5050-00-B-1	ARBF5050-00-B-2

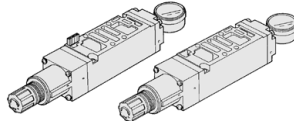

### Blanking plate

It is used by attaching on the manifold block for being prepared for removing a valve for maintenance reasons or planning to mount a spare valve, etc.

Body type	Plug-in type	Non plug-in type
Part no.	VVFS5000-10A	

## Manifold Option

### With exhaust cleaner

#### Plug-in type/Non plug-in type

- Valve exhaust noise dampening: 35 dB or more.
- Oil mist collection: Rate of collection 99.9% or more.
- Piping process reduced.

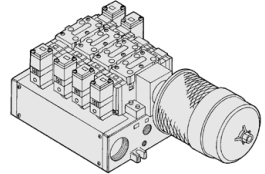

For details, refer to page 992.

### Made to Order

#### Manifold with serial transmission kit Plug-in type

- Solenoid valve wiring process reduced considerably.

For details, refer to page 994.

SV

SYJ

SZ

VF

VP4

VQ  
1/2

VQ  
4/5

VQC  
1/2

VQC  
4/5

VQZ

SQ

VFS

VFR

VQ7

# VFS5000 Series

## Manifold — Plug-in type, Non plug-in type

### Plug-in type (With terminal block): VV5FS5-01T-Station 1-Port size

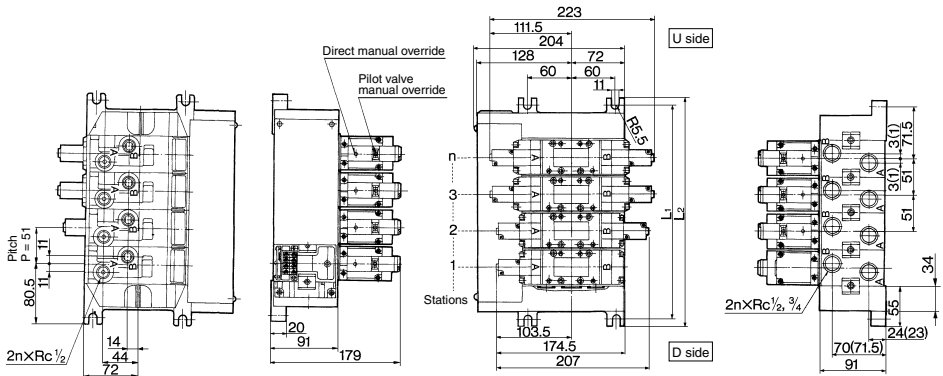

### Bottom ported: VV5FS5-01T-Station 2-Port size

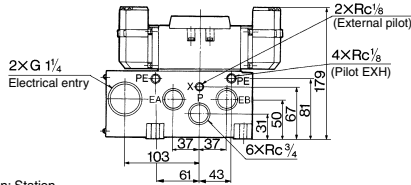

Formula for manifold weight  $M = 0.911n + 1.621$  (kg)  $n$ : Station

( ): 2(B)/4(A) port Rc 3/4

### Non plug-in type: VV5FS5-10-Station 1-Port size

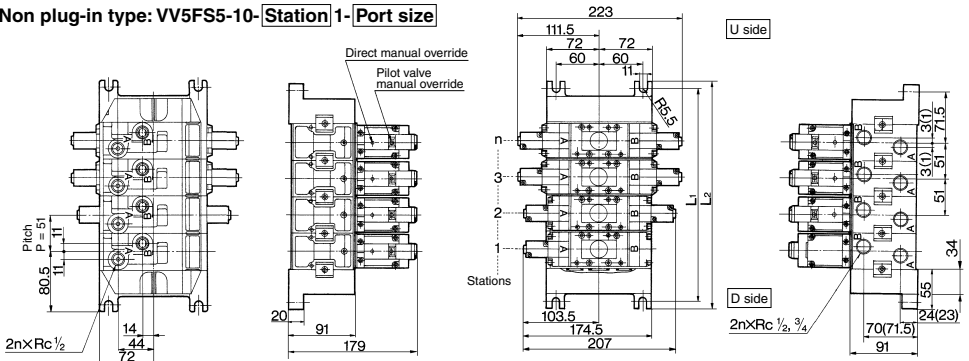

### DIN terminal VV5FS5-10-Station 2-Port size

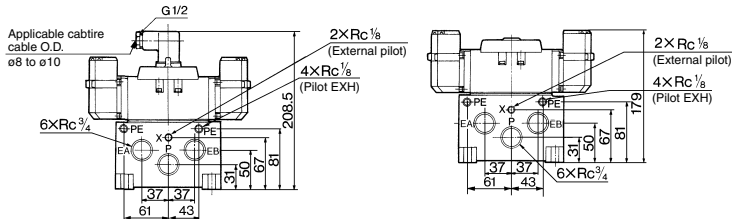

Station	2	3	4	5	6	7	8	9	10	Formula
$L_1$	194	245	296	347	398	449	500	551	602	$L_1 = 51 \times n + 92$
$L_2$	212	263	314	365	416	467	518	569	620	$L_2 = 51 \times n + 110$

Formula for manifold weight  $M = 0.811n + 1.231$  (kg)  $n$ : Station

( ): 2(B)/4(A) port Rc 3/4

**Manifold — Plug-in type with multi-connector/D-sub connector**

Plug-in type with multi-connector: VV5FS5-01CD-Station 1-Port size, VV5FS5-01CU-Station 1-Port size

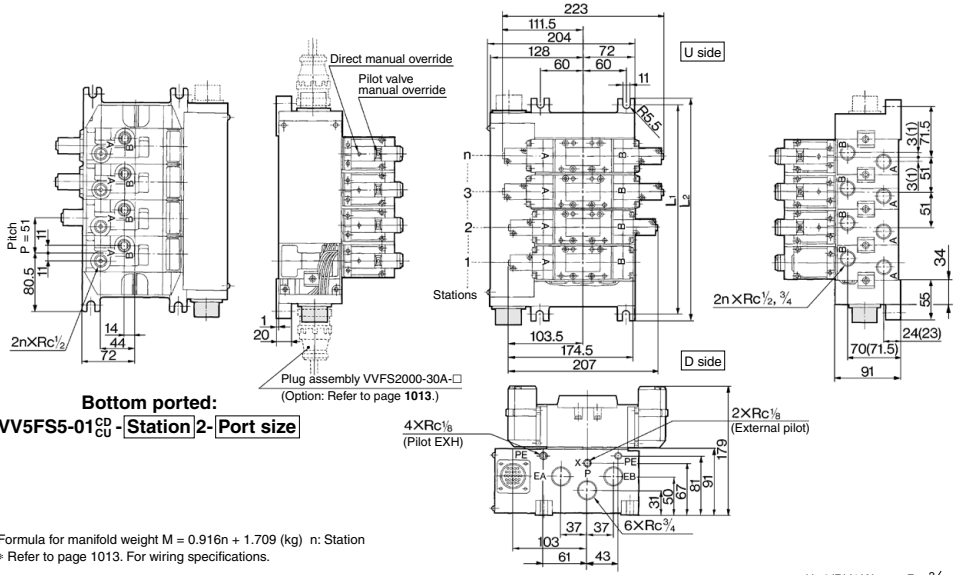

- SV
- SYJ
- SZ
- VF
- VP4
- VQ 1/2
- VQ 4/5
- VQC 1/2
- VQC 4/5
- VQZ
- SQ
- VFS
- VFR
- VQ7

Plug-in type with D-sub connector: VV5FS5-01FD-Station 1-Port size, VV5FS5-01FU-Station 1-Port size

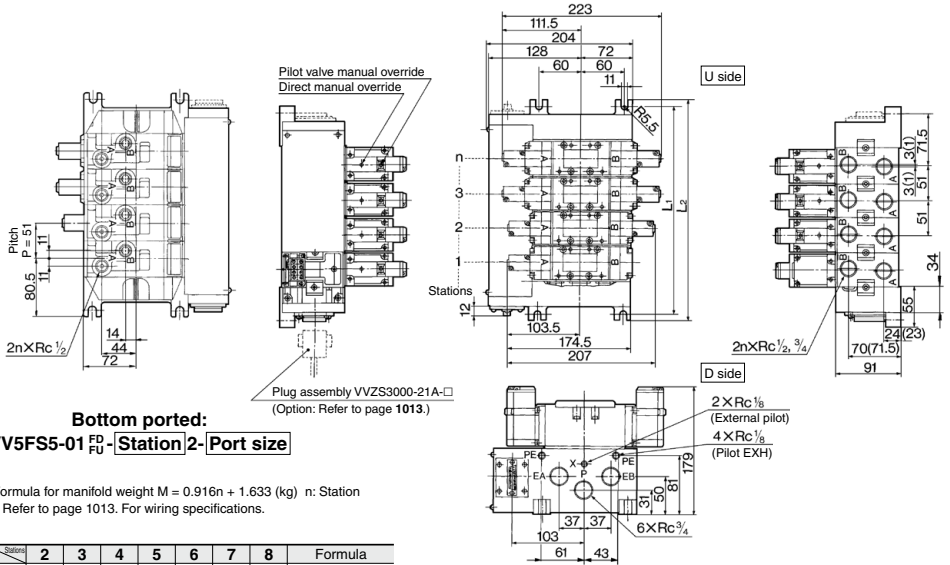

Station	2	3	4	5	6	7	8	Formula
L <sub>1</sub>	194	245	296	347	398	449	500	L <sub>1</sub> = 51 x n + 92
L <sub>2</sub>	212	263	314	365	416	467	518	L <sub>2</sub> = 51 x n + 110

## Manifold with Exhaust Cleaner

- Serves to protect working environment.
- Valve exhaust noise dampening: 35 dB or more.
- Collection rate of drainage and oil mist: 99.9% or more.
- Piping work is reduced.

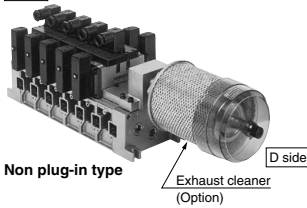
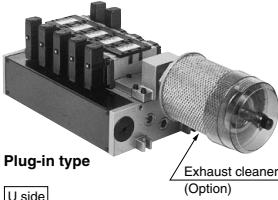

### Manifold Specifications

Manifold	Plug-in type: VV5FS5-01□	Non plug-in type: VV5FS5-10
Wiring	With terminal blocks With multi-connector With D-sub connector	DIN terminal Grommet terminal
Applicable valve model	VFS5□00-□□	VFS5□10-□□, VFS5□10-□□E
Porting specifications	Common SUP/Common EXH	
	Rc	Side: 1/2, 3/4, Bottom: 1/2 (Option)
Stations	2 to 10 <sup>(1)</sup>	
Applicable exhaust cleaners	AMC810-14 (Connecting port size R 1 1/2) <sup>(2)</sup>	

Note 1) With multi-connector, or with D-sub connector: 8 stations max.

Note 2) Exhaust cleaner: Not attached.



### How to Order

**VV5FS5 - 10 - 06 1 - 04 - CD -**

**VFS5000 Series Manifold**

**Base type/Electrical entry**

01T	Plug-in type with terminal block
01C	Plug-in type with multi-connector
01F	Plug-in type with D-sub connector
10	Non plug-in type

**Connector mounting direction**

Symbol	With connector	Applicable base
Nil	None	01T, 10
D	D side mounting	
U	U side mounting	01C, 01F

**Stations**

02	2 stations
:	:
10	10 stations

Base type 01T, 10: 2 to 10 stations  
Base type 01C, 01F: 2 to 8 stations

**CE/UKCA-compliant**

Nil	—
Q	CE/UKCA-compliant

**Exhaust cleaner mounting direction**

Symbol	Exhaust cleaner mounting direction
CD	D side D side mounting
CU	U side U side mounting

**Thread type**

Nil	Rc
N <sup>®</sup>	NPT
T <sup>®</sup>	NPTF
F <sup>®</sup>	G

\* Semi-standard

**Port size**

Symbol	P	A, B
04		1/2
:		
06	3/4	3/4
M		Mixed

\* For bottom ported, 1/2 is only available.

**Symbol**

Symbol	Passage		Porting specifications (A, B)
	P	R1, R2	
1			Side
2	Common	Common	Bottom*

\* Semi-standard

### ⚠ Caution

When using an exhaust cleaner, mount it downwards.

\* Refer to Best Pneumatics No. 7 for Exhaust Cleaner details.

### How to Order Manifold Assembly [Example]

Add the valve and option part numbers in order starting from the first station on the D side.

#### <Example>

- Plug-in type with terminal block (6 stations)
  - (Manifold base) VV5FS5-01T-061-04-CD ..... 1
  - (2 position single) \* VFS5100-5FZ ..... 3
  - (2 position double) \* VFS5200-5FZ ..... 2
  - (Blanking plate) \* VVFS5000-10A ..... 1
  - (Exhaust cleaner) AMC810-14 ..... 1

- Non plug-in type (6 stations)
  - (Manifold base) VV5FS5-10-061-04-CU ..... 1
  - (2 position single) \* VFS5110-5E ..... 3
  - (2 position double) \* VFS5210-5E ..... 2
  - (Blanking plate) \* VVFS5000-10A ..... 1
  - (Exhaust cleaner) AMC810-14 ..... 1

The asterisk denotes the symbol for assembly. Prefix it to the part numbers of the solenoid valve.

**Manifold with Exhaust Cleaner — Plug-in type, Non plug-in type**

Plug-in type: VV5FS5-01T-Station 1-Port size- $\frac{CD}{CU}$

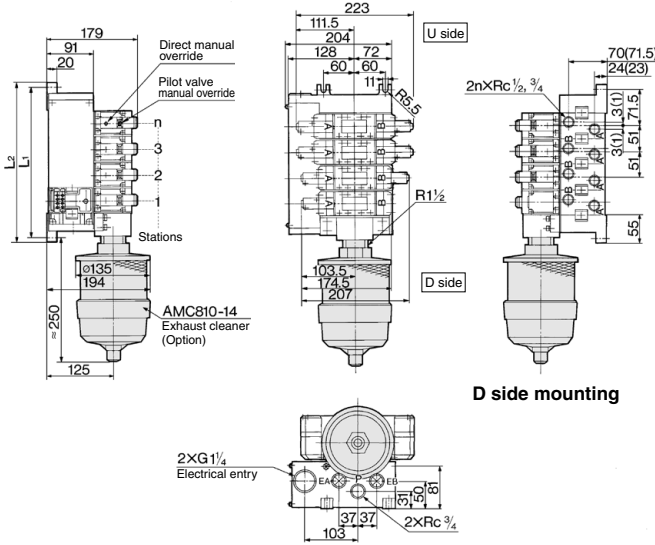

( ): 2(B)/4(A) port Rc 3/4

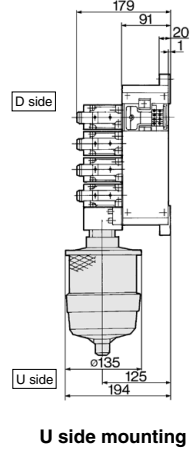

- SV
- SYJ
- SZ
- VF
- VP4
- VQ 1/2
- VQ 4/5
- VQC 1/2
- VQC 4/5
- VQZ
- SQ
- VFS
- VFR
- VQ7

Non plug-in type: VV5FS5-10-Station 1-Port size- $\frac{CD}{CU}$

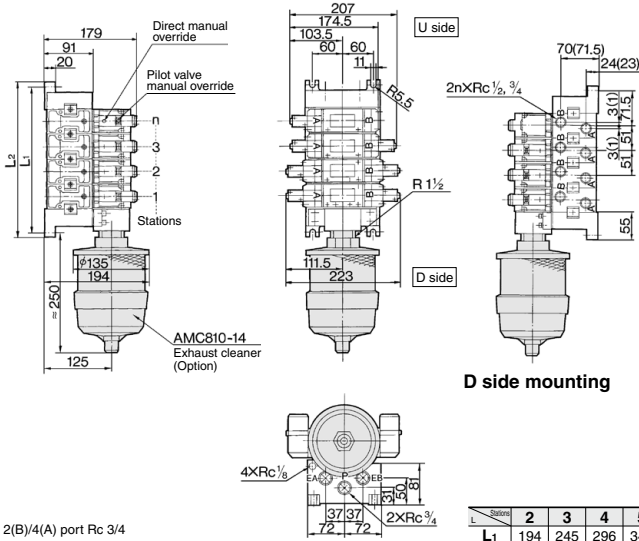

( ): 2(B)/4(A) port Rc 3/4

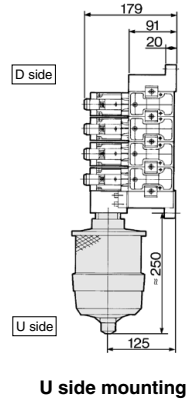

n: Stations

Station	2	3	4	5	6	7	8	9	10	Formula
L <sub>1</sub>	194	245	296	347	398	449	500	551	602	L <sub>1</sub> = 51 x n + 92
L <sub>2</sub>	212	263	314	365	416	467	518	569	620	L <sub>2</sub> = 51 x n + 110

# VFS5000 Series Made to Order

Serial Transmission Kit Manifold: EX123/124 Integrated Type (For Output)  
Serial Transmission System



## How to Order

### How to Order Manifold

VV5FS5 - 01S U V - 08 1 - 04 - X199

**Plug-in type**  
Serial transmission kit

**SI unit mounting position**

D	D side mounting
U	U side mounting

**Stations**

02	2 stations
10	10 stations

**Thread type**

Nil	Rc
N	NPT
T	NPTF
F	G

**Port size**

Symbol	P, R1, R2	A, B
04		1/2
06	3/4	3/4
M		Mixed

\* For bottom ported: 1/2 only

**Combination symbol**

Symbol	Port specification	Piping specification
	P, R1, R2	A, B
1	Common	Common
2*		Side Bottom

\* Semi-standard

Note 1) Max. 10 stations. Add 1 station for serial unit mounting.  
Note 2) Max. 10 Stations: For single and double mixed wiring. (No. of valves: 9)  
Max. 9 stations: For standard double wiring (No. of valves: 8)

**SI unit can be mounted on either U or D side.**

**Applicable models**

Symbol	SI unit part no.		Description
	For U side mounting	For D side mounting	
0	—	—	Without SI unit
H	EX123U-SUH1	EX123D-SUH1	NKE Corporation: Fieldbus H System (16 outputs)
Q	EX124U-SDN1	EX124D-SDN1	DevieNet (2 power supply systems)
R1	EX124U-SCS1	EX124D-SCS1	OMRON Corporation: CompoBus/S (16 outputs) (2 power supply systems)
R2	EX124U-SCS2	EX124D-SCS2	OMRON Corporation: CompoBus/S (8 outputs) (2 power supply systems)
V	EX124U-SMJ1	EX124D-SMJ1	CC-Link (2 power supply systems)

Refer to Best Pneumatics No. 1-1 and the Operation Manual for the details of EX123/124 Integrated-type (For Output) Serial Transmission System. Please download the Operation Manual via our website, <http://www.smcworld.com>

### ● Correspondence of SI unit output numbers and solenoid valve coils

#### <Wiring Example 1> Double wiring (Standard)

D side	U side
SI unit output no.	SI unit
1	2
Double	Double
2	3
Double	Single
3	4
Single	Single
4	5
Single	Single
5	6
Single	Double
6	7
Double	Single
7	8
Single	Single
8	9
Single	SI unit
9	
SI unit	
01	23 45 67 89 1011 1213 1415

#### <Wiring Example 2> Single/Double mixed wiring (Semi-standard)

D side	U side
SI unit output no.	SI unit
1	2
Double	Double
2	3
Double	Single
3	4
Single	Single
4	5
Single	Single
5	6
Single	Double
6	7
Double	Single
7	8
Single	Double
8	9
Double	Single
9	10
Single	SI unit
10	
SI unit	
01	23 4 5 6 78 9 1011 11

\* Mixed wiring is available as a semi-standard. Use the manifold specification sheet to specify this.

### How to Order Valves

VFS5 - 00 - 5 F -

**Symbol**

1	2 position single
2	2 position double
3	3 position closed center
4	3 position exhaust center
5	3 position pressure center
6	3 position double check

**Pilot type**

Nil	Internal pilot
R	External pilot

24 VDC

**Pilot valve manual override**

Nil	Non-locking push type (Flush)
A	Non-locking push type (Extended)
B	Locking type (Tool required)
C	Locking type (Lever)

**Option**

Nil	None
Z	With light/surge voltage suppressor

**Coil rated voltage**

Nil	None
-----	------



# 5 Port Pilot Operated Solenoid Valve Metal Seal, Plug-in/Non Plug-in **VFS5000 Series**

## Serial Transmission Kit Manifold: EX123/124 Integrated Type (For Output) Serial Transmission System

VV5FS5-01S Mounting position Model - Stations Symbol - Port size Thread - X199

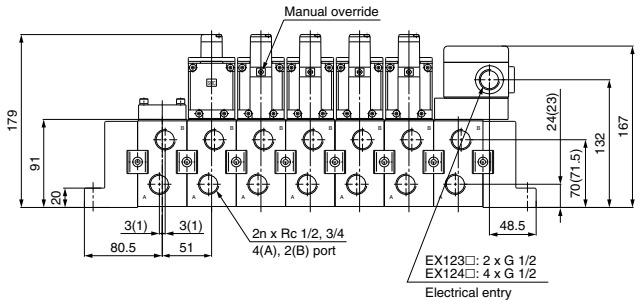
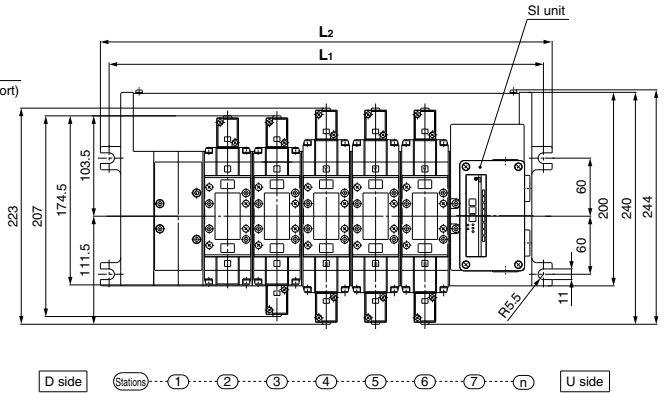
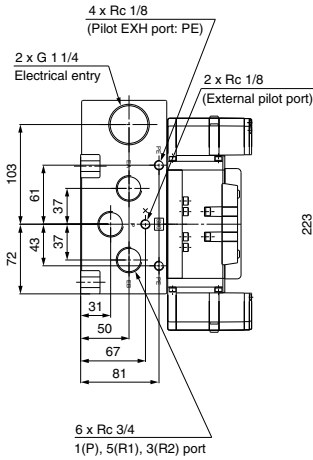

\* Use a dripproof plug assembly (AXT100-B04A) for the unused conduit port (G 1/2).

( ) : 2(B)/4(B) port Rc 3/4

### Dimensions

Formula L<sub>1</sub> = 51n + 92 L<sub>2</sub> = 51n + 110  
n: Stations (Max. 10 stations)

L	n	2	3	4	5	6	7	8	9	10
L <sub>1</sub>		194	245	296	347	398	449	500	551	602
L <sub>2</sub>		212	263	314	365	416	467	518	569	620

Note) Actual number of manifold base stations: Add 1 SI unit mounting station to the number of valve stations.

- SV
- SYJ
- SZ
- VF
- VP4
- VQ 1/2
- VQ 4/5
- VQC 1/2
- VQC 4/5
- VQZ
- SQ
- VFS
- VFR
- VQ7

# VFS5000 Series

## Manifold Option Parts — Plug-in type, Non plug-in type

**Individual SUP spacer:**  
**VVFS5000-P-04-1 (Plug-in type)**  
**VVFS5000-P-04-2 (Non plug-in type)**

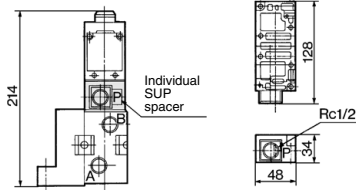

**Double check spacer:**  
**VVFS5000-22A-1 (Plug-in type)**  
**VVFS5000-22A-2 (Non plug-in type)**

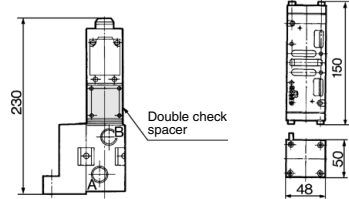

**Individual EXH spacer:**  
**VVFS5000-R-04-1 (Plug-in type)**  
**VVFS5000-R-04-2 (Non plug-in type)**

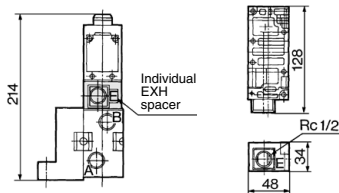

**Interface regulator/P port regulation:**  
**ARBF5050-00-P-1 (Plug-in type)**  
**ARBF5050-00-P-2 (Non plug-in type)**

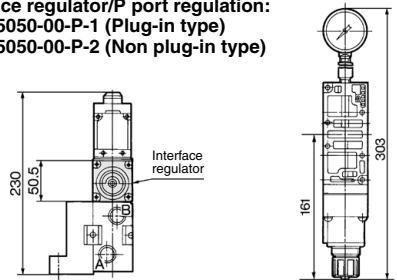

**SUP block plate: AXT628-12A**  
**EXH block plate: AXT512-14-1A**

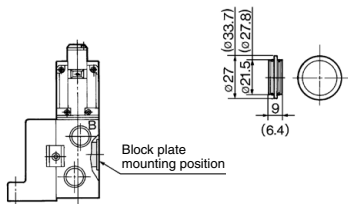

( ) : SUP block plate

**Interface regulator/A port regulation:**  
**ARBF5050-00-A-1 (Plug-in type)**  
**ARBF5050-00-A-2 (Non plug-in type)**

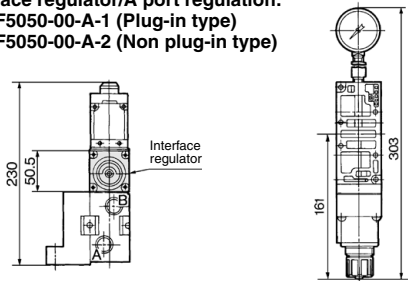

**Throttle valve spacer:**  
**VVFS5000-20A-1 (Plug-in type)**  
**VVFS5000-20A-2 (Non plug-in type)**

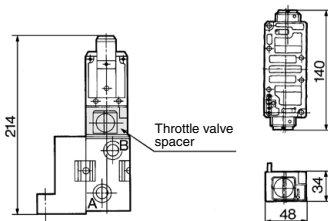

**Interface regulator/B port regulation:**  
**ARBF5050-00-B-1 (Plug-in type)**  
**ARBF5050-00-B-2 (Non plug-in type)**

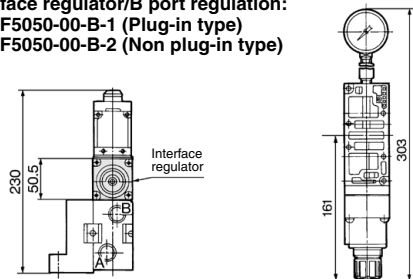

**Manifold Base Construction — Plug-in type, Non plug-in type**

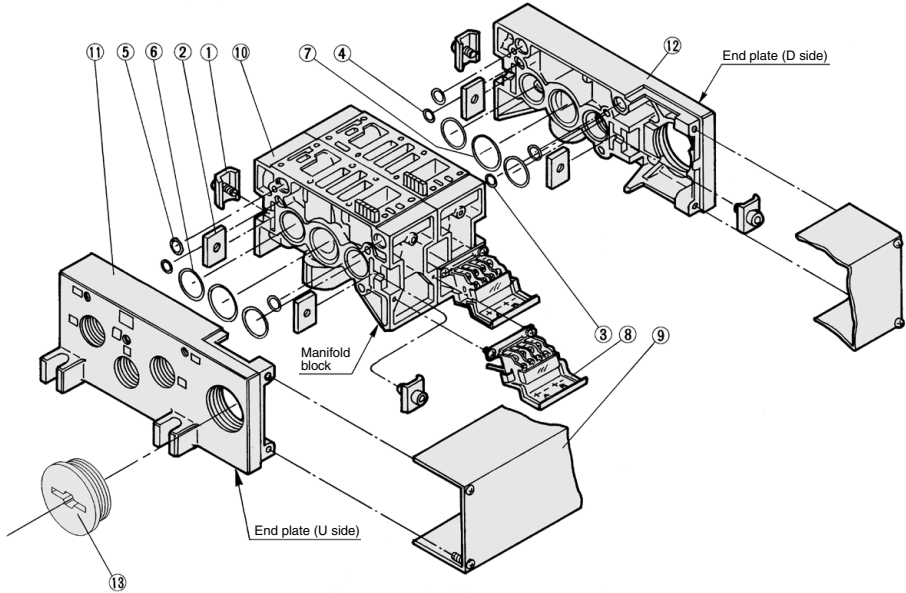

SV
SYJ
SZ
VF
VP4
VQ 1/2
VQ 4/5
VQC 1/2
VQC 4/5
VQZ
SQ
VFS
VFR
VQ7

**Replacement Parts**

No.	Description	Material	Part no.
1	Connection fitting A	Steel plate	AXT628-6-1A
2	Connection fitting B	Steel plate	AXT628-6-2
3	O-ring	NBR	KA00078
4	O-ring	NBR	KA00495
5	O-ring	NBR	KA00328
6	O-ring	NBR	KA00523
7	O-ring	NBR	KA01587
8	Terminal assembly	—	AXT628-5-1A
9	Junction cover assembly	For 01T	VVFS5000-4A- <small>(Stations)</small>
		For 01S□	AZ738-31A- <small>(Stations)</small>
13	Rubber plug	NBR	AXT336-9

• For increasing the manifold bases, please order the manifold block assembly number of the principal part assembly ⑩. For plug-in type: The manifold base with terminal stand (integrated with a junction cover) is required with the ⑨ junction cover assembly.

\* D : For mounting the D side of the SI unit, U : For mounting the U side of the SI unit

**Replacement Parts: Sub Assembly**

(Note) Manifold Base/Construction: Plug-in type with terminal block.

No.	Description	Assembly part no.	Component parts	Applicable manifold base
10	Manifold block assembly	VVFS5000-1A-1- <small>04</small>	Manifold block ⑩, Metal joint ①, ②, Terminal ⑧, O-ring ③, ④, ⑤, ⑥, ⑦, Receptacle assembly	Plug-in type
		VVFS5000-1A-2- <small>04</small>	Manifold block ⑩, Metal joint ①, ②, O-ring ③, ④, ⑤, ⑥, ⑦	Non plug-in type
11	End plate (U side) assembly	VVFS5000-2A-1	End plate (U) ⑪, Metal joint ①, ②	Plug-in type
		VVFS5000-2A-2	End plate (U) ⑪, Metal joint ①, ②	Non plug-in type
12	End plate (D side) assembly	VVFS5000-3A-1	End plate (D) ⑫, Metal joint ①, ②, O-ring ③, ④, ⑤, ⑥, ⑦	Plug-in type
		VVFS5000-3A-2	End plate (D) ⑫, Metal joint ①, ②, O-ring ③, ④, ⑤, ⑥, ⑦	Non plug-in type

# 5 Port Pilot Operated Solenoid Valve Metal Seal, Plug-in/Non Plug-in

## VFS6000 Series



(Details → P. 1008)

### Model

Type of actuation		Model		Port size Rc	Flow rate characteristics						Max. operating cycle (cpm) <sup>(1)</sup>	Response time (ms) <sup>(2)</sup>	Weight (kg) <sup>(3)</sup>
					1 → 4/2 (P → A/B)			4/2 → 5/3 (A/B → R1/R2)					
					C [dm <sup>3</sup> /(s·bar)]	b	Cv	C [dm <sup>3</sup> /(s·bar)]	b	Cv			
2 position	Single	VFS6100	VFS6110	3/4	29	0.10	6.8	38	0.10	9.0	180	160 or less	2.5
				1									
	Double	VFS6200	VFS6210	3/4	29	0.10	6.8	38	0.10	9.0	180	60 or less	2.75

Note 1) Based on JIS B 8419: 2010 (once per 30 days) for the min. operating frequency.

Note 2) Based on JIS B 8419: 2010. (The value at supply pressure 0.5 MPa, ambient/fluid temperature (= 20°C))

However, this excludes when in an adhered state. (Be aware that after long periods of holding time, there may be delays in the initial response time.)

Note 3) The figures in the above list are for without sub-plate. In case of with sub-plate, add 1.65 kg for Rc 3/4 and 1.5 kg for RC 1 respectively.

Note 4) "Note 1)" and "Note 2)" are with controlled clean air.

Note 5) The flow rate characteristics is for the port size Rc 4/3.

Compact yet provides a large flow capacity

3/4: C: 38 dm<sup>3</sup>/(s·bar)

Low power consumption: 1.8 W DC

Easy maintenance

2 types of sub-plates:

Plug-in and non plug-in



### Symbol

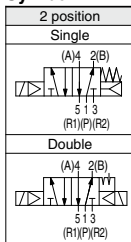

### Standard Specifications

Valve specifications	Fluid	Air		
	Maximum operating pressure	1.0 MPa		
	Minimum operating pressure	0.1 MPa		
	Proof pressure	1.5 MPa		
	Ambient and fluid temperature	-10 to 60°C <sup>(1)</sup>		
	Lubrication	Non-lube <sup>(2)</sup>		
	Pilot valve manual override	Non-locking push type (Flush)		
	Impact/Vibration resistance	150/50 m/s <sup>2</sup> <sup>(3)</sup>		
	Enclosure	Type E: Dustproof (Equivalent to IP50), Type F: Dripproof (Equivalent to IP52), Type D: Splashproof (Equivalent to IP54) <sup>(4)(6)</sup>		
	Electricity specifications	Coil rated voltage	100, 200 VAC, 50/60 Hz; 24 VDC	
Allowable voltage fluctuation		-15 to +10% of rated voltage		
Coil insulation type		Class B or equivalent (130°C) <sup>(5)</sup>		
Apparent power (Power consumption) AC		Inrush	5.6 VA/50 Hz, 5.0 VA/60 Hz	
		Holding	3.4 VA (2.1 W)/50 Hz, 2.3 VA (1.5 W)/60 Hz	
Power consumption DC		1.8 W (2.04 W: With light/surge voltage suppressor)		
Electrical entry		Plug-in type	Conduit terminal	
		Non plug-in type	Grommet terminal, DIN terminal	

Note 1) Use dry air at low temperatures.

Note 2) Use turbine oil Class 1 (ISO VG32), if lubricated.

Note 3) Impact resistance: No malfunction occurred when it is tested with a drop tester in the axial direction and at the right angles to the main valve and armature in both energized and de-energized states every once for each condition. (Values at the initial period)

Vibration resistance: No malfunction occurred in a one-sweep test between 45 and 2000 Hz. Test was performed at both energized and de-energized states in the axial direction and at the right angles to the main valve and armature. (Values at the initial period)

Note 4) Based on JIS C 0920.

Note 5) Based on JIS C 4003.

Note 6) The F and D type enclosures described above show those without the light/surge voltage suppressor.

The F and D type enclosures with the light/surge voltage suppressor are equivalent to IP50.

### Option Specifications

Pilot type	External pilot <sup>(Note)</sup>	
Manual override	Direct manual override	
Coil rated voltage	110 to 120, 220, 240 VAC (50 Hz/60 Hz)	
	12, 100 VDC	
Porting specifications	Bottom ported	
Option	With light/surge voltage suppressor	

Note) Operating pressure: 0 to 1.0 MPa

Pilot pressure: 0.1 to 1.0 MPa

# 5 Port Pilot Operated Solenoid Valve Metal Seal, Plug-in/Non Plug-in **VFS6000 Series**



## How to Order



**Plug-in**



**Non plug-in**

**Body type**

O: Plug-in type sub-plate

F: Plug-in type conduit terminal

**Electrical entry**

E: Grommet terminal

D: DIN terminal without connector

**Porting specifications**

Nil Side ported

**Port size**

Nil	Without sub-plate
06	3/4
10	1

**Thread type**

Nil	Rc
N*	NPT
T*	NPTF
F*	G

\* Semi-standard

**CE/UKCA-compliant**

Nil	—
Q	CE/UKCA-compliant

**Symbol**

2 position single (A)4 (B)2

1

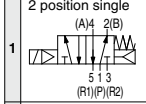

5 1 3 (R1)(P)(R2)

2 position double (A)4 (B)2

2

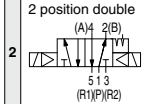

5 1 3 (R1)(P)(R2)

**Body type**

1: Non plug-in type sub-plate

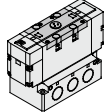

**Body Option**

0	Standard
1*	Direct manual override

\* Semi-standard

**Option**

Nil	None
Z	With light/surge voltage suppressor

**Coil rated voltage**

1	100 VAC, 50/60 Hz
2	200 VAC, 50/60 Hz
3*	110 to 120 VAC, 50/60 Hz
4*	220 VAC, 50/60 Hz
5	24 VDC
6*	12 VDC
7*	240 VAC, 50/60 Hz

\* Semi-standard  
For other rated voltages, please consult with SMC.

**Pilot type**

Nil	Internal pilot
R*	External pilot

\* Semi-standard

VFS6 1 0 0 [ ] - 5 F Z - [ ] 10 [ ] - [ ]

VFS6 1 1 0 [ ] - 5 D Z - [ ] 10 [ ] - [ ]

## How to Order Pilot Valve Assembly

SF4 - 1 F - 22

**Coil rated voltage**

1	100 VAC, 50/60 Hz
2	200 VAC, 50/60 Hz
3*	110 to 120 VAC, 50/60 Hz
4*	220 VAC, 50/60 Hz
5	24 VDC
6*	12 VDC
7*	240 VAC, 50/60 Hz

\* Semi-standard  
For other rated voltages, please consult with SMC.  
\*\* Refer to page 1010 for voltage conversion.

- SV
- SYJ
- SZ
- VF
- VP4
- VQ 1/2
- VQ 4/5
- VQC 1/2
- VQC 4/5
- VQZ
- SQ
- VFS
- VFR
- VQ7

# VFS6000 Series

## Cylinder Speed Chart

Use as a guide for selection.  
Please confirm the actual conditions with SMC Sizing Program.

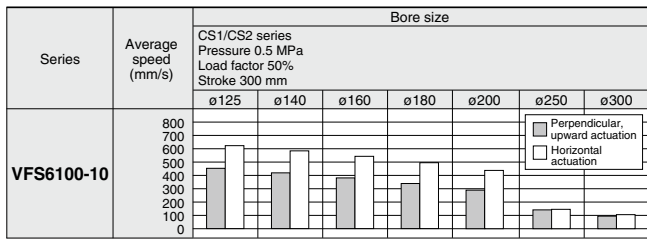

\* It is when the cylinder is extending that is meter-out controlled by speed controller which is directly connected with cylinder, and its needle valve with being fully open.

\* The average velocity of the cylinder is what the stroke is divided by the total stroke time.

\* Load factor: ((Load mass x 9.8)/Theoretical force) x 100%

## Conditions

	CS1/CS2 series
VFS6100-10	Tube bore x Length SGP25A x 1 m
	Speed controller AS600-10
	Silencer AN600-10

## Construction

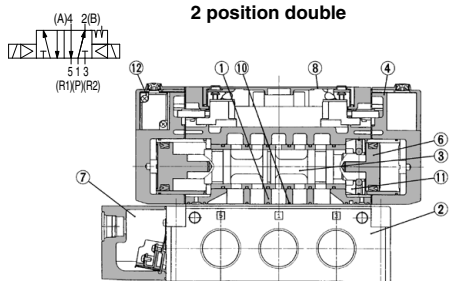
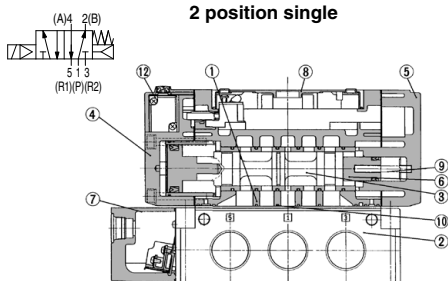

## Component Parts

No.	Description	Material	Note
1	Body	Aluminum die-casted	Platinum silver
2	Sub-plate	Aluminum die-casted	Platinum silver
3	Spool/Sleeve	Stainless steel	—
4	Adapter plate	Aluminum die-casted	Black
5	End plate	Aluminum die-casted	Black
6	Piston	Resin	—
7	Junction cover	Resin	—
8	Light cover	Resin	—
9	Return spring	Stainless steel	—
10	Gasket	NBR	—
11	Detent assembly	—	—
12	Pilot valve assembly	—	—

\* Refer to "How to Order Pilot Valve Assembly" on page 999.

## Sub-plate Assembly Part No.

Plug-in	VFS6000-P- <sup>06</sup> / <sub>10</sub> (N, T, F)
Non plug-in	VFS6000-S- <sup>06</sup> / <sub>10</sub> (N, T, F)

\* Mounting bolt and gasket are not included.

## Sub-plate Assembly (For External Pilot) Part No.

Plug-in	VFS6000-P-R <sup>06</sup> / <sub>10</sub> (N, T, F)
Non plug-in	VFS6000-S-R <sup>06</sup> / <sub>10</sub> (N, T, F)

Part no. for mounting bolt and gasket	<sup>06</sup> / <sub>10</sub> BG-VFS6000
---------------------------------------	--

5 Port Pilot Operated Solenoid Valve  
Metal Seal, Plug-in/Non Plug-in **VFS6000 Series**

**Plug-in — 2 Position single/Double**

**2 position single: VFS6100-□F**

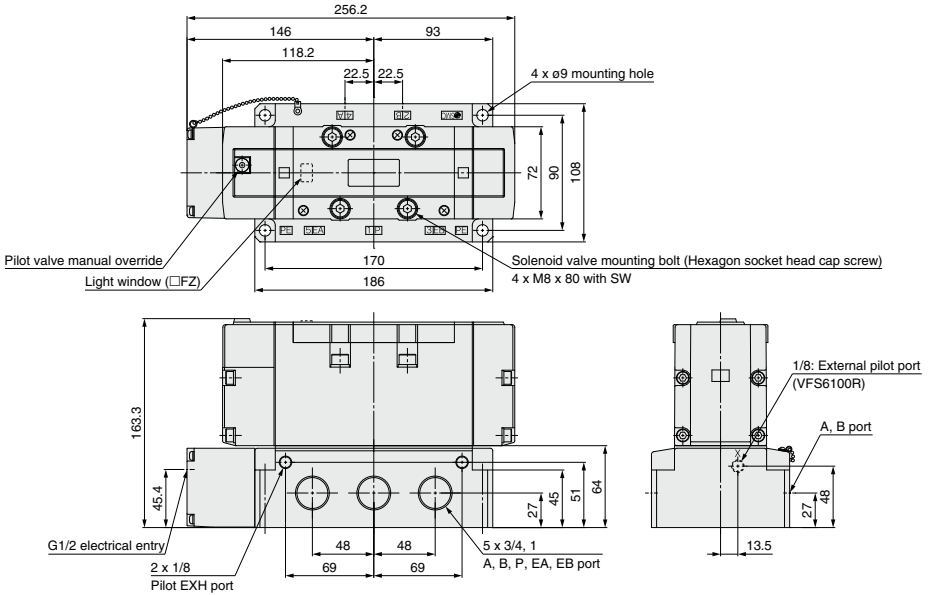

**2 position double: VFS6200-□F**

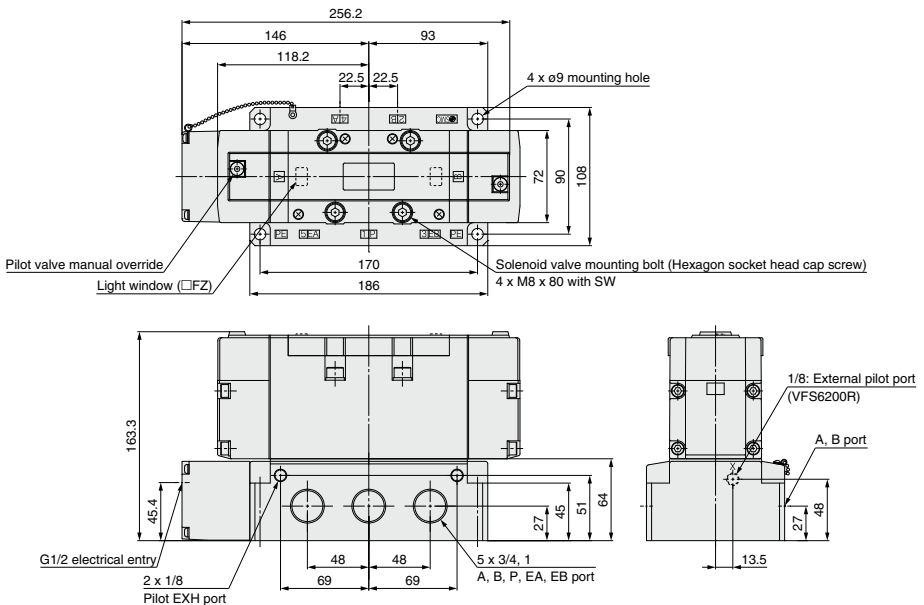

SV
SYJ
SZ
VF
VP4
VQ 1/2
VQ 4/5
VQC 1/2
VQC 4/5
VQZ
SQ
<b>VFS</b>
VFR
VQ7

# VFS6000 Series

## Non Plug-in — 2 Position single/Double

### 2 position single: VFS6110-□E, VFS6110-□D

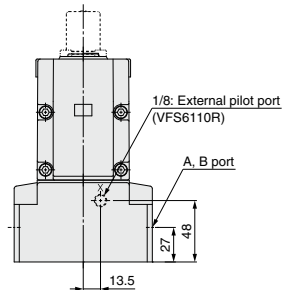
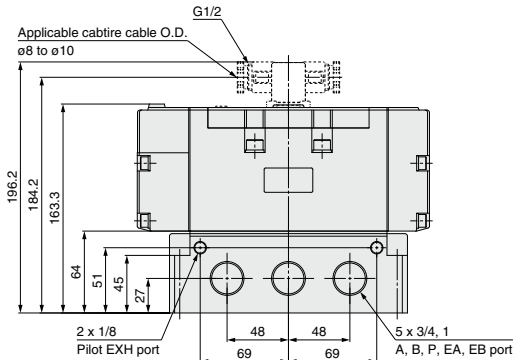
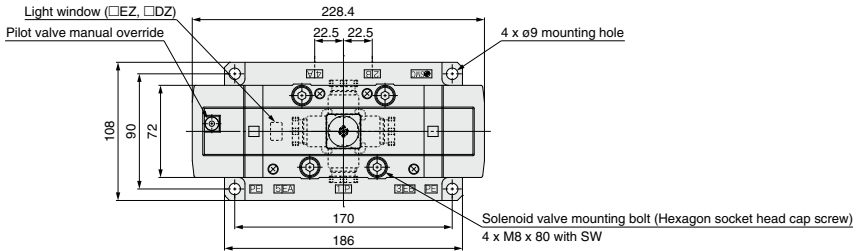

### 2 position double: VFS6210-□E, VFS6210-□D

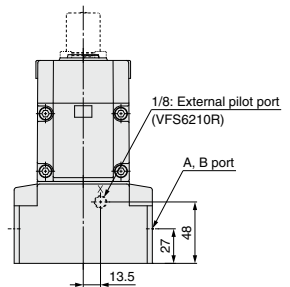
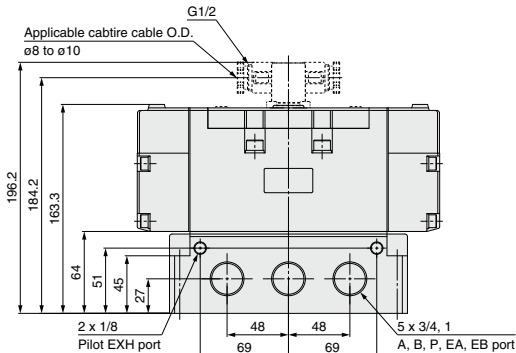
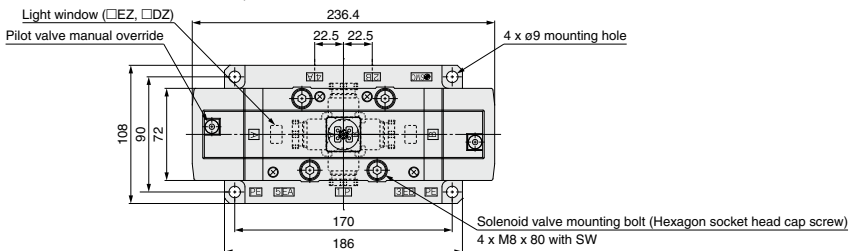



<b>SV</b>
<b>SYJ</b>
<b>SZ</b>
<b>VF</b>
<b>VP4</b>
VQ 1/2
VQ 4/5
VQC 1/2
VQC 4/5
<b>VQZ</b>
<b>SQ</b>
<b>VFS</b>
<b>VFR</b>
<b>VQ7</b>

# 5 Port Pilot Operated Solenoid Valve Metal Seal, Non Plug-in

## VFS2000 Series



### How to Order

Non plug-in



30 - VFS2 2 10 [ ] - 1 D [ ] [ ] - [ ] 02 [ ]

Conforming to CSA standard

Symbol

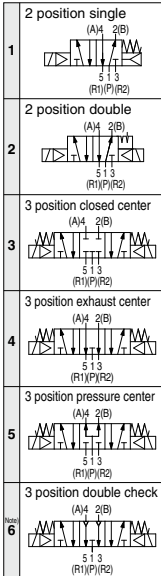

Note) Combining double check spacer with external pilot will not work.

Body type

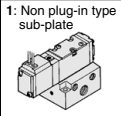

Pilot type

N11	Internal pilot
R*	External pilot

\* Option: External pilot is possible only to the one with sub-plate.

Coil rated voltage

1	100 VAC, 50/60 Hz
2	200 VAC, 50/60 Hz
3*	110 to 120 VAC, 50/60 Hz
4*	220 VAC, 50/60 Hz
5	24 VDC
6*	12 VDC
7*	240 VAC, 50/60 H

\* Semi-standard

Thread type

N11	Rc
N*	NPT
T*	NPTF
F*	G

\* Semi-standard

Port size

N11	Without sub-plate	
01	1/8	Non plug-in type, Standard type
02	1/4	



Porting specifications

N11	Side ported
B*	Bottom ported

\* Semi-standard

Pilot valve manual override

N11: Non-locking push type (Flush)	B*: Locking type (Tool required)
A*: Non-locking push type (Extended)	C*: Locking type (Lever)

\* Semi-standard

Option

N11	None
Z	With light/surge voltage suppressor

Electrical entry

D: DIN terminal

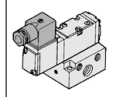

Refer to standard products for specifications and dimensions.

# 5 Port Pilot Operated Solenoid Valve Metal Seal, Non Plug-in

## VFS3000 Series



### How to Order

Non plug-in

30 - VFS3 2 1 1 - 2 D - - 02



Conforming to  
CSA standard

#### Symbol

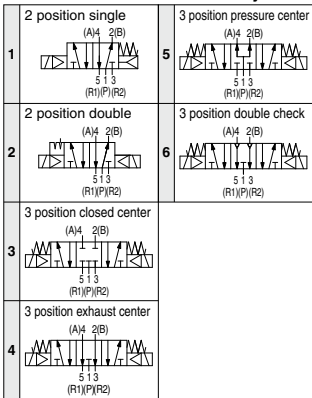

\* Reverse pressure: Can be used by external pilot specifications.

#### Body type

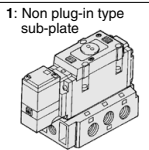

#### Body option

0	Standard
1*	Direct manual override

\* Semi-standard

#### Thread type

Nil	Rc
N*	NPT
T*	NPTF
F*	G

\* Semi-standard

#### Port size

Nil	Without sub-plate
02	1/4
03	3/8

\* For bottom ported, 1/4 is only available.

#### Porting specifications

Nil	Side ported
B*	Bottom ported

\* Semi-standard

#### Option

Nil	None
Z	With light/surge voltage suppressor

#### Electrical entry

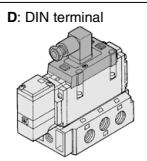

#### Coil rated voltage

1	100 VAC, 50/60 Hz
2	200 VAC, 50/60 Hz
3*	110 to 120 VAC, 50/60 Hz
4*	220 VAC, 50/60 Hz
5	24 VDC
6*	12 VDC
7*	240 VAC, 50/60 Hz

\* Semi-standard

#### Pilot type

Nil	Internal pilot
R*	External pilot

\* Semi-standard

#### Pilot valve manual override

Nil: Non-locking push type (Flush)



A\*: Non-locking push type (Extended)



B\*: Locking type (Tool required)



C\*: Locking type (Lever)



\* Semi-standard

Refer to standard products for specifications and dimensions.

SV  
SYJ  
SZ  
VF  
VP4  
VQ  
1/2  
VQ  
4/5  
VQC  
1/2  
VQC  
4/5  
VQZ  
SQ  
VFS  
VFR  
VQ7

# 5 Port Pilot Operated Solenoid Valve Metal Seal, Non Plug-in

## VFS4000 Series



### How to Order

Non plug-in



**30 - VFS4 2 1 0 - 1 D - 03**

Conforming to CSA standard

Thread type

Nil	Rc
N*	NPT
T*	NPTF
F*	G

\* Semi-standard

Port size

Nil	Without sub-plate
03	3/8
04*	1/2

\* EA, EB: 3/8

Porting specifications

Nil	Side ported
B*	Bottom ported

\* In the case of external pilot (Option), bottom piping is not available.

Symbol

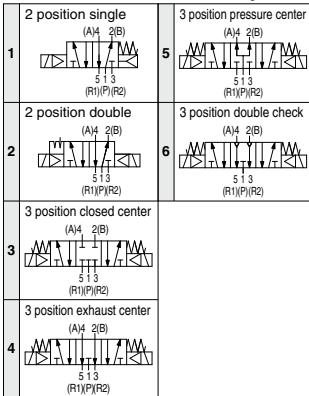

\* Reverse pressure: Can be used by external pilot specifications.

Body type

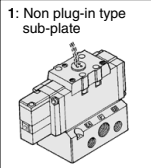

0	Standard
1*	Direct manual override

\* Semi-standard

Body option

Option

Nil	None
Z	With light/surge voltage suppressor

Electrical entry

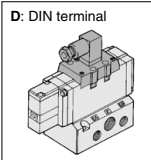

Coil rated voltage

1	100 VAC, 50/60 Hz
2	200 VAC, 50/60 Hz
3*	110 to 120 VAC, 50/60 Hz
4*	220 VAC, 50/60 Hz
5	24 VDC
6*	12 VDC
7*	240 VAC, 50/60 Hz

\* Semi-standard

Pilot type

Nil	Internal pilot
R*	External pilot

\* Semi-standard

Pilot valve manual override

Nil: Non-locking push type (Flush)



A\*: Non-locking push type (Extended)



B\*: Locking type (Tool required)



C\*: Locking type (Lever)



\* Semi-standard

Refer to standard products for specifications and dimensions.

# 5 Port Pilot Operated Solenoid Valve Metal Seal, Non Plug-in

# VFS5000 Series



## How to Order

Non plug-in

30 - VFS5 1 1 0 - 5 D - 06



Conforming to  
CSA standard

Port size

Nil	Without sub-plate
03	3/8
04	1/2
06	3/4

Porting specifications

Nil	Side ported
B*	Bottom ported

\* In the case of external pilot (Option), bottom piping is not available.

Thread type

Nil	Rc
N*	NPT
T*	NPTF
F*	G

\* Semi-standard

Symbol

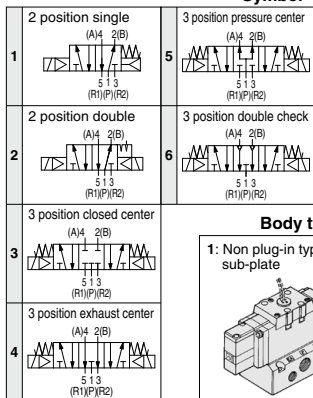

Body type

1: Non plug-in type sub-plate

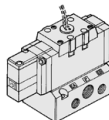

Body option

0	Standard
1*	Direct manual override

\* Semi-standard

Pilot type

Nil	Internal pilot
R*	External pilot

\* Semi-standard

Coil rated voltage

1	100 VAC, 50/60 Hz
2	200 VAC, 50/60 Hz
3*	110 to 120 VAC, 50/60 Hz
4*	220 VAC, 50/60 Hz
5	24 VDC
6*	12 VDC
7*	240 VAC, 50/60 Hz

\* Semi-standard

Electrical entry

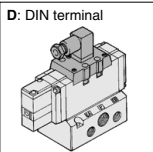

Pilot valve manual override

Nil: Non-locking push type (Flush)



A\*: Non-locking push type (Extended)



B\*: Locking type (Tool required)



C\*: Locking type (Lever)



\* Semi-standard

Option

Nil	None
Z	With light/surge voltage suppressor

Refer to standard products for specifications and dimensions.

SV  
SYJ  
SZ  
VF  
VP4  
VQ  
1/2  
VQ  
4/5  
VQC  
1/2  
VQC  
4/5  
VQZ  
SQ  
VFS  
VFR  
VQ7

# 5 Port Pilot Operated Solenoid Valve Metal Seal, Non Plug-in

# VFS6000 Series



## How to Order

Non plug-in



**30 – VFS6 1 1 0 [ ] – 5 D Z – [ ] 10 [ ]**

Conforming to CSA standard

### Symbol

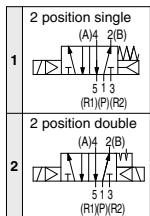

### Body type

1: Non plug-in type sub-plate

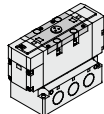

### Body option

0	Standard
1*	Direct manual override

\* Semi-standard

### Pilot type

Nil	Internal pilot
R*	External pilot

\* Semi-standard

### Thread type

Nil	Rc
N*	NPT
T*	NPTF
F*	G

\* Semi-standard

### Port size

Nil	Without sub-plate
06	3/4
10	1

### Porting specifications

Nil	Side ported
-----	-------------

### Option

Nil	None
Z	With light/surge voltage suppressor

### Electrical entry

D: DIN terminal

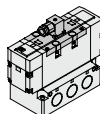

### Coil rated voltage

1	100 VAC, 50/60 Hz
2	200 VAC, 50/60 Hz
3*	110 to 120 VAC, 50/60 Hz
4*	220 VAC, 50/60 Hz
5	24 VDC
6*	12 VDC
7*	240 VAC, 50/60 Hz

\* Semi-standard

Refer to standard products for specifications and dimensions.



# VFS Series

## Specific Product Precautions 1

Be sure to read this before handling the products.

Refer to back page 50 for Safety Instructions and pages 3 to 9 for 3/4/5 Port Solenoid Valve Precautions.

### ⚠ Caution

## Light/Surge Voltage Suppressor, Electrical Entry

## Single unit

### Body Ported

### VFS1000/2000/3000 Series

### Light/Surge Voltage Suppressor

#### AC and 100 VDC

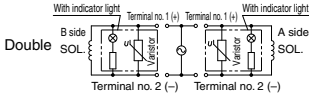
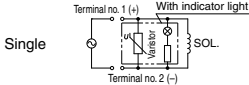

#### 24 VDC or less

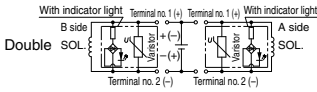
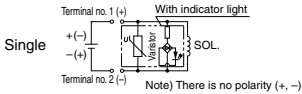

- Type G: Lead wire comes directly from the solenoid part. Connect it with the power source. Grommet with DC voltage surge voltage suppressor has polarity. Connect red lead wire to + (positive) side and black to - (negative) side.

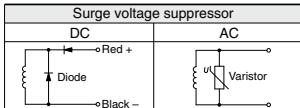

### Wiring

In the case of DIN terminal and terminal block (with indicator light/surge voltage suppressor), the interior wiring is shown below.

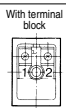
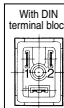

Applicable terminal: 1.25-3, 1.25-3S, 1.25Y-3N, 1.25Y-3S, but in the case of with DIN terminal block, is not a terminal structure.

(Note) There is no polarity.

### Changing Direction of DIN Terminal/Cable Entry

To change direction of DIN terminal retaining screw, pull off outer cover, rotate connector board through 180°. Replace cover and tighten screw.

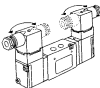

### Changing Direction of Electrical Entry and Manual Override

Loosen the set screw (M3-2 pcs.), take out pilot operator, turn solenoid valve 180° degrees to change the direction of lead wire and manual override. (Possible on the VFS1000 series only.)



### Base Mounted

### VFS2000 Series

### Light/Surge Voltage Suppressor

- In the case of surge voltage suppressor, surge voltage absorption device ZNR is attached to AC power.

#### AC and 100 VDC

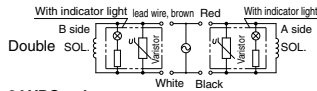
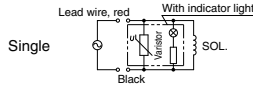

#### 24 VDC or less

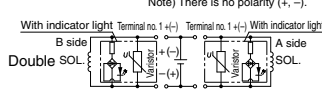
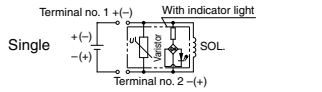

- Type G: Use lead wire from solenoid to connect with power side. Grommet with DC voltage surge voltage suppressor has polarity. Connect red lead wire to + (positive) side and black to - (negative) side.

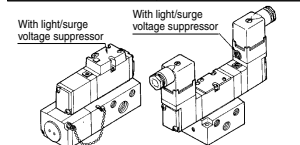
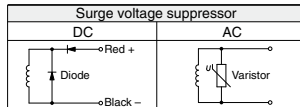

### Plug-in type

### Non plug-in type

### How to Exchange

#### Solenoid valve

- Loosen 3 set screws (hexagonal socket head cap screw M3 x 31) and pull solenoid valve out vertically, otherwise it may cause damage to the solenoid valve. Never remove a valve at an angle.
- When mounting solenoid valve onto the base, plug pin assembly (base side) into receptacle assembly (body-side) vertically.

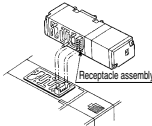

#### Exchange of pilot valve (Voltage exchange)

- When changing rated voltage and electrical entry etc., pilot valve assembly can be changed. But in case of a plug-in type with light/surge voltage suppressor, pilot valve assembly cannot be changed for changing rated voltage.

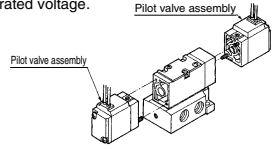

#### • When mounting pilot valve assemblies and solenoid valve bodies, tighten equally with the tightening torque shown in the right to prevent gaskets from slipping.

Pilot Valve Assembly SF4-□□□	
Holding screw	Proper tightening torque (N·m)
M3	0.45 to 0.6
Solenoid Valve Body	
Holding screw	Proper tightening torque (N·m)
M3	0.8 to 1.2

### Electrical Connection

#### Single unit/Plug-in type sub-plate: T

#### Conduit terminal (With terminal block)

- If the junction cover (1) of the sub-plate is removed, you can see the plug-in type terminal block (2) (part no. NVF2000-27A-1) mounted inside the sub-plate. The following markings are on the terminal block board. Connect with corresponding power side.

Description	Solenoid A side	Solenoid B side
Terminal block marking	A	B
	+	-

- There is no polarity.
- When ground wiring and COM wiring are required, please specify separately.
- Applicable terminal: 1.25-3, 1.25-3S, 1.25Y-3N, 1.25Y-3S

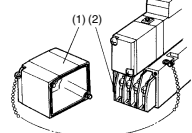

#### Single unit/Non plug-in type sub-plate: G, E, T, D

- Type G: Use lead wire from solenoid to connect with power side.
- Type E, T, D: In the case of a DIN terminal and terminal block (with light/surge voltage suppressor), the interior wiring is shown below. Connect with corresponding power side.

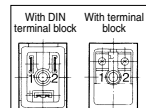

(Note) There is no polarity.

### Changing Direction of DIN Terminal/Cable Entry

- Change of the electrical entry of DIN type connector cable Unscrew retaining screw, pull off outer cover, rotate connector board through 180°. Replace cover and tighten screw. Applicable cable: O.D. ø6 to ø8.

SV

SYJ

SZ

VF

VP4

VQ

1/2

VQ

4/5

VQC

1/2

VQC

4/5

VQZ

SQ

VFS

VFR

VQ7



# VFS Series

## Specific Product Precautions 2

Be sure to read this before handling the products.

Refer to back page 50 for Safety Instructions and pages 3 to 9 for 3/4/5 Port Solenoid Valve Precautions.

### ⚠ Caution

## Light/Surge Voltage Suppressor, Electrical Entry

## Single unit

### Base Mounted

### VFS3000/4000/5000/6000 Series

#### Light/Surge Voltage Suppressor

In the case of surge voltage suppressor, surge voltage absorption element is attached to terminal block on body area.

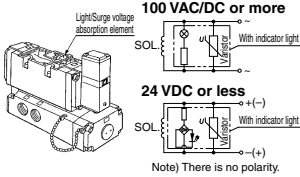

#### How to Exchange

##### Solenoid valve

- Loosen set screw and take solenoid valve out vertically, otherwise it may cause damage to the solenoid valve. Never remove a valve at an angle.
- When mounting solenoid valve onto the base, plug pin assembly (base side) into receptacle assembly (body side) vertically.

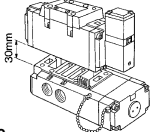

##### Pilot valve

- When changing the rated voltage, electrical entry, etc., pilot valve assembly can be exchanged easily since this is plug-in type. Then, when changing the rated voltage with indicator light/surge voltage suppressor, change of indicator light/surge voltage suppressor substrate is also needed. So, order together with pilot valve assembly.

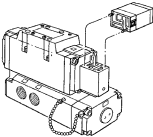

#### VFS3000/4000/5000

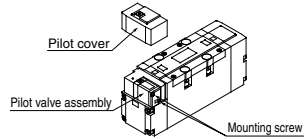

#### VFS6000

#### Light/Surge Voltage Suppressor Substrate Part No.

VFS3000	VFS3000-10A-□#1
100V or more	VF4000-9A-□#1
24V or less	VF4000-9B-□#1
VFS5000	AXT627-7A-□#1
24V or less	AXT627-7B-□#1
VFS6000	VF4000-9A-□#1
24V or less	VF4000-9B-□#1

□: Coil rated voltage. Symbol: Refer to below.  
 1: 100 to 120 V    6: 12 V  
 2: 200 to 220 V    7: 240 V  
 5: 24 V

- When mounting pilot valve assemblies and solenoid valve bodies, tighten equally with the tightening torque shown in the right to prevent gaskets from slipping.

#### Pilot Valve Assembly

Holding screw	Proper tightening torque (N·m)
M3	0.45 to 0.6

#### Solenoid Valve Body

Holding screw	Proper tightening torque (N·m)
M3	0.8 to 1.2
M4	1.4 to 2.5
M5	2.8 to 5

#### Lead Wire Connection

##### DIN terminal block type

- Male pin terminal of DIN terminal block board of solenoid valve and wires as shown below. Connect to corresponding terminal block on the connector.

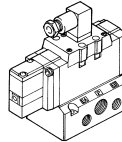

##### DIN terminal (Wiring)

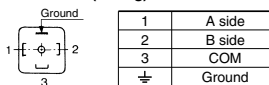

- There is no polarity.

#### 100 VAC/DC or more

##### Single

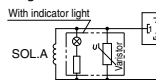

##### Double

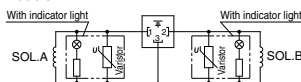

#### 24 VDC or less

##### Single

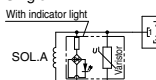

##### Double

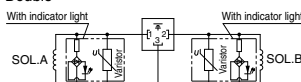

- Heavy-duty cord  
Applicable cable O. D.: ø8 to ø10
- Applicable terminal  
Applicable terminal on block board: 3 (kinds)  
1.25Y-3L, 1.25-3.5S, 1.25-4M
- Connector/Clamping torque  
Set screw 0.6 N·m  
Terminal screw 0.6 N·m
- Incorrect common (DIN terminal no. 3) causes damage on power side circuit.

#### Plug-in type (With terminal)

- If the junction cover (1) of the sub-plate is removed, you can see the plug-in type terminal block (2) mounted inside the sub-plate.

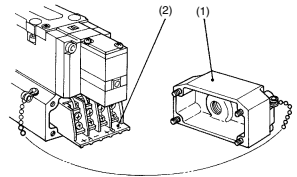

- The following markings are on the terminal block. Connect with corresponding power side.

Terminal block marking	Solenoid A side		Solenoid B side	
	A	B	B	A
	+	-	-	+

- Applicable terminal:  
VFS3000: 1.25-3, 1.25-3S, 1.25Y-3N, 1.25Y-3S  
VFS4000: 1.25-3.5M, 1.25Y-3L, 1.25Y-3M  
VFS5000: 1.25-4, 1.25-4M  
VFS6000: 1.25-3.5M, 1.25Y-3L, 1.25-3M
- There is no polarity.
- Tightening torque for terminal: 0.6 N·m

#### Non plug-in type (With terminal)

- Remove cover (1), over terminal block (2) attached to the inside of body. Connect with corresponding power side. For a type with indicator light and surge voltage suppressor, pull out the light and surge voltage suppressor substrate (3) in a straight direction and then connect them.

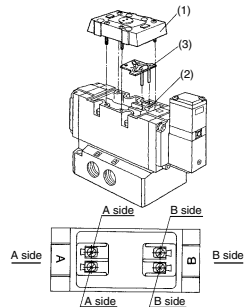

- Applicable terminal:  
VFS3000: 1.25-3, 1.25-3S, 1.25Y-3N, 1.25Y-3S  
VFS4000/5000/6000: 1.25-3.5M, 1.25Y-3L, 1.25Y-3M
- There is no polarity.
- Tightening torque for terminal: 0.6 N·m





# VFS Series Specific Product Precautions 3

Be sure to read this before handling the products.

Refer to back page 50 for Safety Instructions and pages 3 to 9 for 3/4/5 Port Solenoid Valve Precautions.

## ⚠ Caution

### How to Calculate the Flow Rate

Refer to front matter for How to Calculate the Flow Rate.

## Interface Regulator Specifications

Interface regulator <sup>(3) (4)</sup>	ARBF2000	ARBF3050	ARBF4050	ARBF5050							
Applicable solenoid valve series	VFS2000	VFS3000	VFS4000	VFS5000							
Regulating port	P	A B P	A B P	A B P							
Proof pressure	1.5 MPa										
Maximum operating pressure	1.0 MPa										
Set pressure range <sup>(1)</sup>	0.05 to 0.83 MPa		0.1 to 0.83 MPa								
Ambient and fluid temperature	-5 to 60°C (No freezing)										
Port size for connection of pressure gauge	M5 x 0.8	Rc 1/8									
Weight (kg)	0.16	0.46	0.72	0.83							
Effective area at supply side (mm <sup>2</sup> ) <sup>(2)</sup>	P → A	5.5	21	18.5	11	35	31	26	44	38	32
S at P <sub>1</sub> = 0.7 MPa, P <sub>2</sub> = 0.5 MPa	P → B	5.1	18.5	22	12	31	31	24	38	40	31
Effective area at exhaust side (mm <sup>2</sup> ) <sup>(2)</sup>	A → EA	12	40		55		90				
S at P <sub>2</sub> = 0.5 MPa	B → EB	11	36		45		77				

Note 1) Set within the operating pressure range of solenoid valve.

Note 2) Synthesized effective area with solenoid valve 2 position single type.

Note 3) Operate an interface regulator only by applying pressure from the "P" port of the base, except when using it as a reverse pressure valve.

- To combine a pressure center valve and the A and B port pressure reduction of an interface regulator, use the ARBF3000, 4000, or 5000 model.
- To combine a reverse pressure valve and an interface regulator, use the ARBF3000, 4000, or 5000 model. Furthermore, the P port Pressure reduction cannot be used for the reverse pressure valve.
- When combining a double check valve and an interface regulator, use a manifold or sub-plate as a basis, and stack them in the following order; the perfect spacer → the interface regulator → the valve.
- When a closed center valve is combined with the interface regulator's A, B port regulation, note that it cannot be used for intermediate stops of a cylinder because there is leakage from relief port on the regulator.

Note 4) Note that the pressure gauge (G27) for the ARBF2000-00-P cannot be used for the oil lubricating air.

### Flow Rate Characteristics (P → A)

(Representative value conditions: Inlet pressure 0.7 MPa, when 2 position solenoid valve is mounted.)

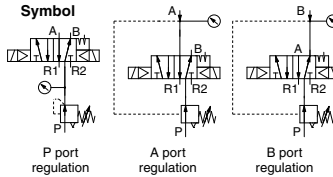

#### ARBF2000-00-P

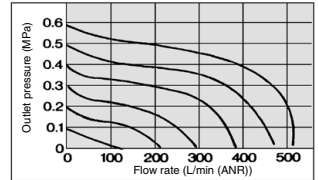

#### ARBF3050-00-P

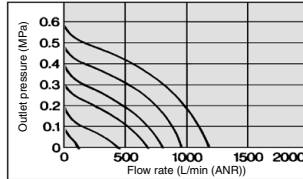

#### ARBF3050-00-A

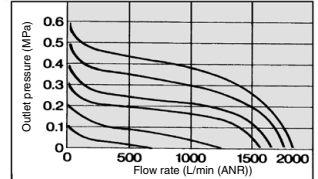

#### ARBF4050-00-P

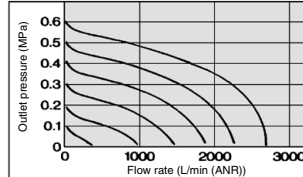

#### ARBF4050-00-A

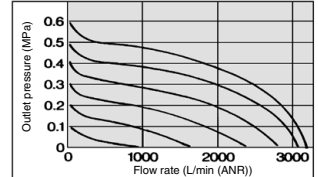

#### ARBF5050-00-P

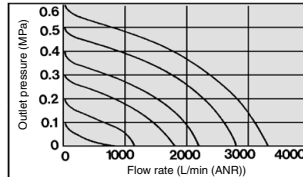

#### ARBF5050-00-A

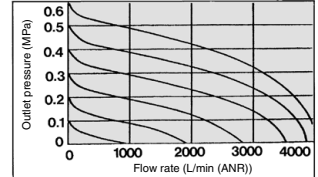

SV

SYJ

SZ

VF

VP4

VQ 1/2

VQ 4/5

VQC 1/2

VQC 4/5

VQZ

SQ

VFS

VFR

VQ7



# VFS Series Specific Product Precautions 4

Be sure to read this before handling the products.

Refer to back page 5 for Safety Instructions and pages 3 to 9 for 3/4/5 Port Solenoid Valve Precautions.

## ⚠ Caution

### Lead Wire Connection Manifold/Plug-in

#### Type 01 Insert Plug with Lead Wire

##### VFS2000 Series

(Insert plug with lead wire is not available for the VF3000, 4000, and 5000 series.)

##### How to remove junction cover (Type 01)

Turn the knob (2) of junction cover (1) on the manifold block side by hand or slotted screwdriver to the C → O direction (counterclockwise) 90°. While holding the knob and upper part of junction cover, pull outward to remove junction cover.

When reassembling, do the opposite.

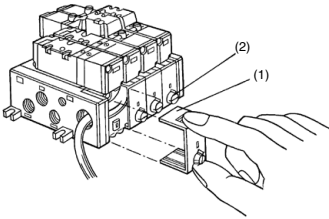

##### Wiring

The insert plug (1) is attached to the manifold block and lead wire is plugged in with valve side as shown in the following list.

(Single solenoid: AXT624-52A-S-1)  
(Double solenoid: AXT624-52A-D-1)

Connect with corresponding power side.

Power supply	Valve model	Solenoid A	Solenoid B
AC DC	Single solenoid	Red, Black	—
	Double solenoid	Red, Black	Brown, White

- \* There is no polarity.
- \* Lead wire length is 1 m.

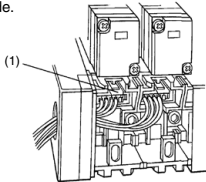

##### How to Use Insert Plug

- When removing insert plug (1) from manifold base, push the lever area (2) of inset plug downward with thumb and pull it together with the lead wire (3) outward.

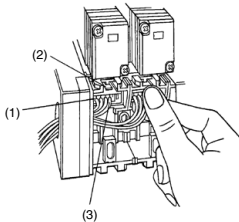

- When placing the inset plug (1) into the manifold base, push the lever area of inset plug with thumb and plug it in its place in the receptacle housing (4) horizontally. After plugging, pull lead wire out a little bit to ensure that inset plug is secure.

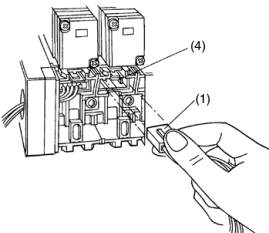

#### Type 01 with Terminal Block

##### VFS2000 Series

- Remove junction cover of manifold, exposing terminal block attached to the manifold block. Lead wires from solenoid valve are connected with the terminals on upper side of terminal block. (On the terminal block, lead wire is connected with both A and B sides of solenoid valve in accordance with the corresponding markings A and B on the block.) Connect each lead wire of power side corresponding to respective solenoid valve on the lower terminal block. VFS2000 has the marking + COM on the block board, but - COM specification is also available.

Model	Terminal block marking	A	COM	B
VFS2100		A side	COM	
VFS2200		A side	COM	B side
VFS2300		A side	COM	B side

- Applicable terminal: 1.25-3, 1.25-3S, 1.25Y-3N, 1.25Y-3S
- Plugging COM bridge (part no. AXT625-73: 5 stations) in between each + COM on the block board will make the specifications of all the stations + COM and enables you to understand the wiring process. (It is designed for 5 stations. So, cut the COM bridge according to the number of stations. Additionally, when it is used for 6 or more stations, combine the COM bridges and cut appropriately.)

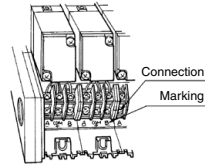

- There is no polarity.
- Tightening torque for terminal: 0.6 N·m

##### VFS3000 Series

Model	Terminal block marking	A	COM	B
VFS3100		A side	COM	
VFS3200		A side	COM	B side
VFS3300		A side	COM	B side

- Applicable terminal: 1.25-3.5M, 1.25Y-3L, 1.25-3M
- Plugging the lead wire assembly for all COM in between COM terminals on the block board will make the specifications of all the stations all COM. This rationalizes the wiring. Part no. of lead wire assembly for all COM (common to VFS3000, 4000, and 5000): AZ683-56A (Since it is designed for 20 terminals, the VFS3000 is applicable to up to 20 stations. Cut lead wires appropriately according to the number of stations.)
- There is no polarity.
- VFS 3000 has the marking + COM on the block board, but - COM specification is also available.
- Tightening torque for terminal: 0.6 N·m

##### VFS4000/5000 Series

Model	Terminal block marking	A +	A -	B +	B -
VFS4100		A side	A side		
VFS4200		A side	A side	B side	B side
VFS4300		A side	A side	B side	B side
VFS4400		A side	A side	B side	B side

- Applicable terminal: 1.25-3.5M, 1.25Y-3L, 1.25Y-3M
- Plugging the lead wire assembly for all COM in between COM terminals on the block board will make the specifications of all the stations all COM. This rationalizes the wiring. Part no. of lead wire assembly for all COM (common to VFS3000, 4000, and 5000): AZ683-56A (Since it is designed for 20 terminals, the VFS4000 and 5000 are applicable to up to 10 stations. Cut lead wires appropriately according to the number of stations.)
- There is no polarity.
- Tightening torque for terminal: 0.6 N·m



# VFS Series Specific Product Precautions 5

Be sure to read this before handling the products.  
Refer to back page 50 for Safety Instructions and pages 3 to 9 for 3/4/5 Port Solenoid Valve Precautions.

## ⚠ Caution

### Lead Wire Connection Manifold/Plug-in

#### Type 01C Circular Connector

##### VFS2000/3000/4000/5000 Series

###### • Wire connection specifications

Lead wire for both solenoid A and B sides in manifold are connected to connector terminal as COM specifications.

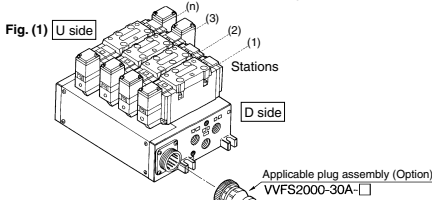

#### Internal Wiring of Manifold

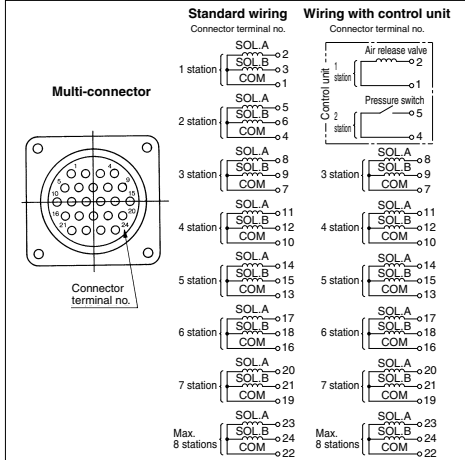

Note 1) Maximum stations are 8.  
Note 2) There is no polarity.  
Note 3) Indication of stations are one station from D side regardless of the connector mounting side, D or U.

#### Applicable Plug Assembly (Option)

Assembly part no.	Cable length	Component parts
VVFS2000-30A-1	1.5 m	
VVFS2000-30A-2	3 m	Plug 206837-1 1 pc. Cable clamp 206138-1 1 pc. Socket 66101-2 24 pcs. Cable VCTF 24 cores x 0.75 mm <sup>2</sup> made by Tyco Electronics AMP K.K.
VVFS2000-30A-3	5 m	
VVFS2000-30A-4 *	7 m	
VVFS2000-30A-5 *	10 m	
VVFS2000-30A-6 *	15 m	
VVFS2000-30A-7 *	20 m	

\* Option

#### Cable Color List of Each Terminal No.

Terminal no.	1	2	3	4	5	6	7	8	9	10	11	12
Lead wire color	Orange	Orange	Black	Black	Green	Green	Red	Red	Blue	Blue	Yellow	Yellow
Dot marking	—	Yes	—	Yes	—	Yes	—	Yes	—	Yes	—	Yes

Terminal no.	13	14	15	16	17	18	19	20	21	22	23	24	25
Lead wire color	Brown	Brown	White	White	Pink	Pink	Gray	Gray	Sky blue	Sky blue	Light green	Light green	Gray
Dot marking	—	Yes	—	Yes	—	Yes	—	Yes	—	Yes	—	Yes	—

#### Type 01F D-sub Connector

##### VFS2000/3000/4000/5000 Series

###### • Wire connection specifications

Lead wire for both solenoid A and B sides in manifold are connected to connector terminal as COM specifications.

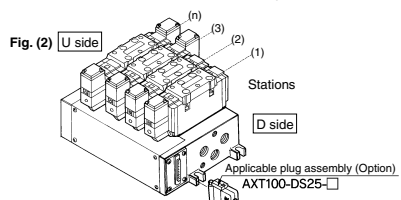

#### Internal Wiring of Manifold

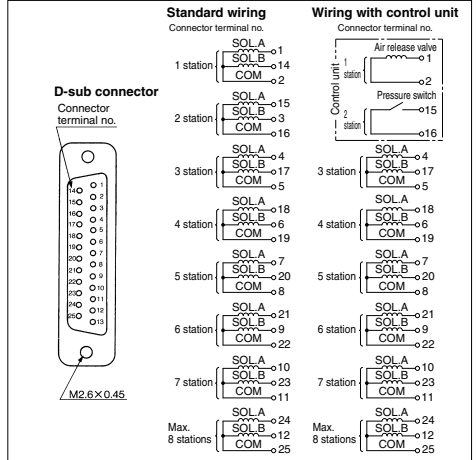

Note 1) Maximum stations are 8.  
Note 2) There is no polarity.  
Note 3) Indication of stations are one station from D side regardless of the connector mounting side, D or U.

#### Applicable Plug Assembly (Option)

Assembly part no.	Cable length	Component parts
AXT100-DS25-015	1.5 m	Plug: MIL standard D type connector 25 terminals Cable: 25 cores wire x 0.3 mm <sup>2</sup>
AXT100-DS25-030	3 m	
AXT100-DS25-050	5 m	
AXT100-DS25-080	8 m	
AXT100-DS25-100	10 m	
AXT100-DS25-150	15 m	
AXT100-DS25-200	30 m	
AXT100-DS25-300	20 m	

#### Cable Color List of Each Terminal No.

Terminal no.	1	2	3	4	5	6	7	8	9	10	11	12	13
Lead wire color	Black	Black	Red	Red	Orange	Yellow	Pink	Purple	Gray	White	White	Yellow	Orange
Dot marking	—	—	—	—	—	—	—	—	White	Black	Black	Red	Red

Terminal no.	14	15	16	17	18	19	20	21	22	23	24	25
Lead wire color	Yellow	Pink	Blue	Purple	Gray	Orange	Red	Brown	Pink	Gray	Black	White
Dot marking	Black	Black	White	—	—	Black	White	White	Red	Red	White	—