

5 Port Solenoid Valve **Plug-in Type**

S0700 Series



Flow rate characteristics

C[dm³/(s·bar)]: **0.39**
 b: **0.39**
 cv: **0.11**

Power consumption

0.35 w

Possible to drive cylinders
Up to ø25
 (At 300 mm/s)

| |
|-------|
| SJ |
| SY |
| SY |
| S0700 |
| S0700 |

Slim Compact Bar Base

Height

Reduced by 20 mm

(Compared with plug-in manifold stacking base)

Maintenance
 Easy replacement only with two mounting screws

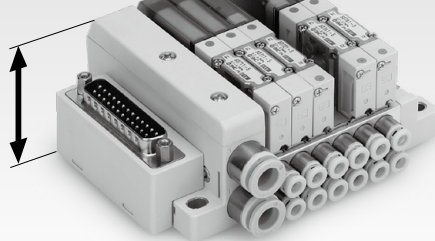

Installation volume

Approx. **45%*** reduction

*: 4-station manifold

Installation area

Approx. **18%*** reduction

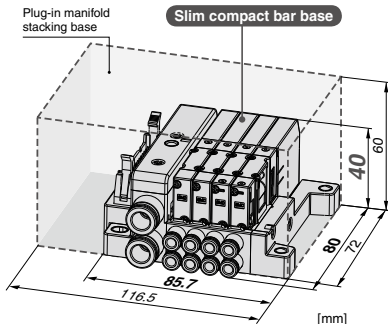

Plug-in Type Stacking Base

Fieldbus System (Serial Transmission) Compatible Protocols

DeviceNet



CANopen



EtherNet/IP

EtherCAT









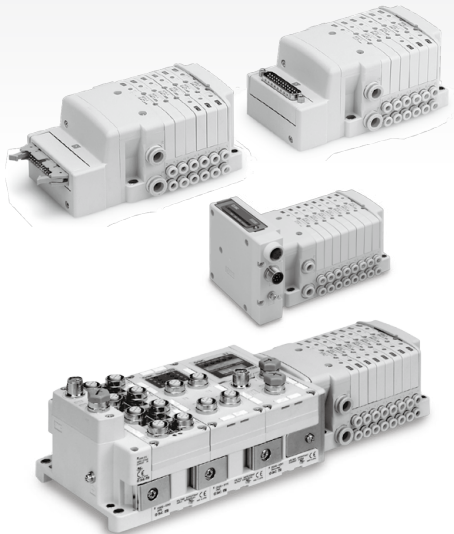



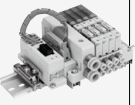

ETHERNET POWERLINK

EtherNet/IP™ and PROFINET are compatible with wireless systems.

- D-sub connector
- Flat ribbon cable
- Terminal block box
- Lead wire
- Circular connector



Plug-in Manifold Variations

| | | S Kit Serial Transmission (Fieldbus System) | | | | | |
|---------------------------------------|--|---|---|---|---|---|--|
| | | EX180 | EX260 | EX250 | EX600 | EX500 | EX510 |
| | | For Output | For Output | For Input/Output | For Input/Output | Gateway-type | Gateway-type |
| Slim Compact Bar Base |  | — | — | — | — | — |  |
| | Page 654 | | | | | | Page 656 |
| Plug-in Type Stacking Base | — |  |  |  |  |  | — |
| | | Page 676 | Page 678 | Page 680 | Page 684 | Page 686 | |
| | DeviceNet | ● | ● | ● | ● | ● | ● |
| | CC-Link | ● | ● | ● | ● | ● | ● |
| Applicable Network |  | ● | ● | ● | ● | ● | ● |
| |  | ● | ● | ● | ● | ● | ● |
| |  | ● | ● | ● | ● | ● | ● |
| |  | ● | ● | ● | ● | ● | ● |
| |  | ● | ● | ● | ● | ● | ● |
| |  | ● | ● | ● | ● | ● | ● |
| |  | ● | ● | ● | ● | ● | ● |
| EtherNet/IP™ compatible wireless base | | | | ● | ● | | |
| PROFINET compatible wireless base | | | | ● | ● | | |

4-Position Dual 3-Port Valve



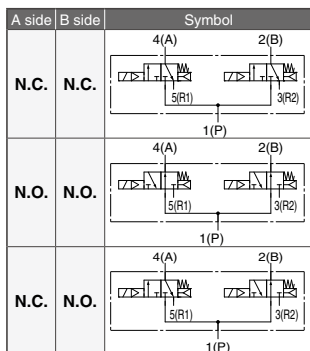



- Two 3-port valves in one body.
- Independently operating 3-port valve at each side of A and B.
- Number of stations occupied for 3-port valve halved.
- Available as 4-position 5-port valve.

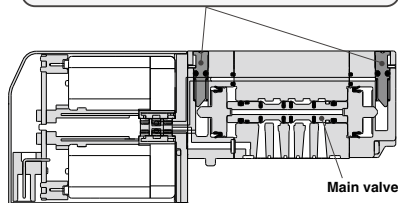

Adopted Direct Manual.

Possible to switch the main valve reliably by direct manual override even when pressure is below the operating pressure range during maintenance.

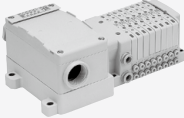

| F Kit D-sub Connector | P Kit Flat Ribbon Cable | T Kit Terminal Block Box | L Kit Lead Wire | M Kit Circular Connector |
|---|--|--|--|---|
| MIL Standard | MIL Standard •26 pins, 20 pins | | | |
|  Page 660 |  Page 664 | — | — | — |
|  Page 690 |  Page 694 |  Page 702 |  Page 706 |  Page 710 |

SJ
SY
SY
S0700
S0700

Optimum Actuation Size Chart of Air Cylinder

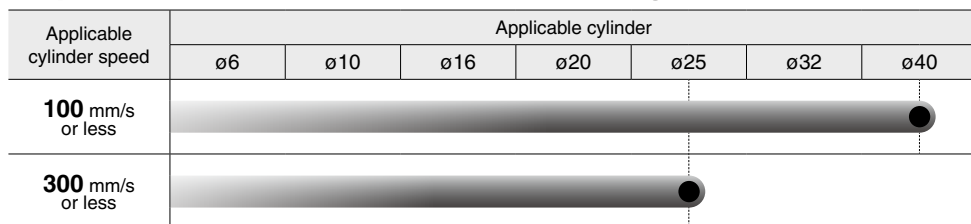

For horizontal operation. Refer to page 652 for calculation conditions.

5 Port Solenoid Valve **Plug Lead Type** **S0700 Series**

For details, refer to page 735.

- Valve width: **7.4 mm**
- Power consumption: **0.35 W**

Body Ported

- Flow rate characteristics $C[\text{dm}^3/(\text{s}\cdot\text{bar})]$: **0.6**
- Possible to drive cylinders: **Up to ø25** (300 mm/s)
- Weight: **39 g**

Single unit

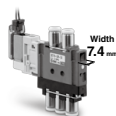

Width
7.4 mm

Manifold

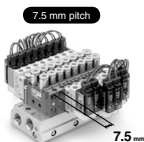

7.5 mm

Base Mounted

- Flow rate characteristics $C[\text{dm}^3/(\text{s}\cdot\text{bar})]$: **0.39**
- Possible to drive cylinders: **Up to ø25** (300 mm/s)

Single unit



Width 7.4 mm

Manifold

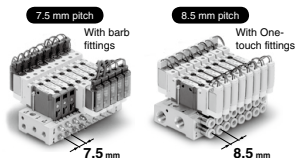

7.5 mm pitch

With barb fittings

8.5 mm pitch



With One-touch fittings

7.5 mm

8.5 mm

Serial transmission/EX510

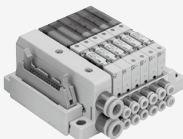
Variations/Options

| Base model | | Slim Compact Bar Base | | Plug-in Type Stacking Base | | |
|---|---|---|-----------------------------|---|------------|--|
| | |  | Page 653 |  | Page 675 | |
| Piping spec. | Port size | 1(P), 3(R) | ø6, ø8, ø1/4", ø5/16" | | | |
| | | 4(A), 2(B) | ø2, ø3.2, ø4, ø1/8", ø5/32" | | | |
| Type of wiring | S Kit | EX510 | ● | | — | |
| | | EX180 | ● | | — | |
| | | EX500 | — | | ● | |
| | | EX250 | — | | ● | |
| | | EX260 | — | | ● | |
| | | EX600 | — | | ● | |
| | F Kit | D-sub connector | ● | | ● | |
| | P Kit | Flat ribbon cable | ● | | ● | |
| | T Kit | Terminal block box | — | | ● | |
| L Kit | Lead wire | — | | ● | | |
| M Kit | Circular connector | — | | ● | | |
| Options | Blanking plate | | ● Page 718 | | ● Page 718 | |
| | External pilot [-R] | | ● Page 718 | | ● Page 718 | |
| | Direct EXH outlet with built-in silencer [-S] | | ● Page 718 | | ● Page 718 | |
| | Individual SUP/EXH spacer | | — | | ● Page 719 | |
| | Individual SUP spacer | | ● Page 719 | | — | |
| | Individual EXH spacer | | ● Page 719 | | — | |
| | SUP block plate | | — | | ● Page 719 | |
| | EXH block plate | | — | | ● Page 720 | |
| | Back pressure check valve [-B] | | — | | ● Page 720 | |
| | Blanking plate with output | | ● Page 720 | | ● Page 720 | |
| | Port plug | | ● Page 721 | | ● Page 721 | |
| | DIN rail mounting bracket | | ● Page 721 | | ● Page 721 | |
| | Applicable to DIN rail mounting | | ● Page 721 | | ● Page 721 | |
| | Blanking plug (For One-touch fitting) KJP-02 KQ2P-23/04/06 | | ● Page 722 | | ● Page 722 | |
| | Silencer (For EXH port) | | ● Page 722 | | ● Page 722 | |
| | Name plate[-N] SS0700-N-Station (1 to Max. stations) | | — | | ● Page 722 | |
| | Dual flow fitting | | — | | ● Page 723 | |
| | SUP/EXH block | | — | | ● Page 723 | |
| Double check block (Separated) VQ1000-FPG-□□ | | ● Page 724 | | ● Page 724 | | |

INDEX

| | |
|------------------------------------|----------|
| Variations | Page 646 |
| Variations/Options | Page 648 |
| Valve Specifications | Page 650 |
| Manifold Specifications | Page 651 |
| Cylinder Speed Chart, Symbol | Page 652 |

SJ

SY

SY

S0700

S0700

Slim Compact Bar Base

S Kit

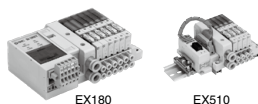

| | |
|--|----------|
| Serial Transmission S Kit | Page 653 |
|--|----------|

F Kit



P Kit



| | |
|------------------------------------|----------|
| D-sub Connector F Kit | Page 659 |
|------------------------------------|----------|

| | |
|--------------------------------------|----------|
| Flat Ribbon Cable P Kit | Page 663 |
|--------------------------------------|----------|

| | |
|--------------------|----------|
| Construction | Page 671 |
|--------------------|----------|

| | |
|------------------------------|----------|
| Manifold Exploded View | Page 672 |
|------------------------------|----------|

Plug-in Type Stacking Base

S Kit



| | |
|--|----------|
| Serial Transmission S Kit | Page 675 |
|--|----------|



EX500

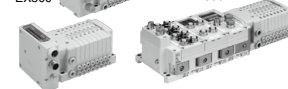

EX600

| | |
|------------------------------------|----------|
| D-sub Connector F Kit | Page 689 |
|------------------------------------|----------|

| | |
|--------------------------------------|----------|
| Flat Ribbon Cable P Kit | Page 693 |
|--------------------------------------|----------|

| | |
|---------------------------------------|----------|
| Terminal Block Box T Kit | Page 701 |
|---------------------------------------|----------|

| | |
|------------------------------|----------|
| Lead Wire L Kit | Page 705 |
|------------------------------|----------|

| | |
|---------------------------------------|----------|
| Circular Connector M Kit | Page 709 |
|---------------------------------------|----------|

F Kit



P Kit



| | |
|--------------------|----------|
| Construction | Page 713 |
|--------------------|----------|

| | |
|------------------------------|----------|
| Manifold Exploded View | Page 714 |
|------------------------------|----------|

| | |
|-------------------------------|----------|
| Manifold Optional Parts | Page 718 |
|-------------------------------|----------|

T Kit



L Kit



| | |
|------------------------------------|----------|
| Specific Product Precautions | Page 725 |
|------------------------------------|----------|

| | |
|-----------------------|----------|
| Troubleshooting | Page 733 |
|-----------------------|----------|

M Kit



S0700 Series Valve Specifications

Valve Specifications

Model

| Type | Type of actuation | Model | Flow rate characteristics | | | | | | Response time [msec] ⁺¹ | Weight [g] | |
|---|-------------------|-------------------|--|------|------|-----------------------------|------|------|------------------------------------|------------|----|
| | | | 1→4/2 (P→A/B) | | | 4/2→5/3 (A/B→R1/R2) | | | | | |
| | | | C[dm ³ /(s·bar)] | b | Cv | C[dm ³ /(s·bar)] | b | Cv | | | |
| Slim compact Bar base Page 653 | 2-position | Single | S0711 | 0.39 | 0.39 | 0.11 | 0.37 | 0.39 | 0.10 | 18 or less | 36 |
| | | Double | S0721 | 0.39 | 0.39 | 0.11 | 0.37 | 0.39 | 0.10 | 10 or less | 41 |
| | 4-pos. | Dual 3-port valve | S07 ^A _B 1 _C | 0.34 | 0.34 | 0.09 | 0.33 | 0.33 | 0.08 | 18 or less | 41 |
| Plug-in type Stacking base Page 675 | 2-position | Single | S0710 | 0.39 | 0.39 | 0.11 | 0.37 | 0.39 | 0.10 | 18 or less | 30 |
| | | Double | S0720 | 0.39 | 0.39 | 0.11 | 0.37 | 0.39 | 0.10 | 10 or less | 38 |
| | 4-pos. | Dual 3-port valve | S07 ^A _B 0 _C | 0.34 | 0.34 | 0.09 | 0.33 | 0.33 | 0.08 | 18 or less | 38 |

*: Values for cylinder port fitting port size C6.

*1: Based on JIS B 8419-2010 (Supply pressure: 0.5 MPa, with indicator light and surge voltage suppressor, clean air. This will change depending on pressure and air quality.) The value when ON for the double type.

Specifications

| | | | |
|---|--------------------------------------|------------------------------|----------------------------|
| Valve specifications | Valve construction | Rubber seal | |
| | Fluid | Air | |
| | Maximum operating pressure | 0.7 MPa | |
| | Minimum operating pressure | 0.2 MPa | |
| | Ambient and fluid temperature | -10 to 50°C ⁺¹ | |
| | Maximum operating cycle | 5 Hz | |
| | Pilot valve exhaust method | Slim compact Bar base | Plug-in type Stacking base |
| | | Common exhaust ⁺² | |
| | Pilot valve manual override | Push type | |
| | Lubrication | Not required | |
| Impact/Vibration resistance⁺³ | 30/100 m/s ² | | |
| Enclosure | IP40 | | |
| Electrical specifications | Coil rated voltage | 24 VDC | |
| | Allowable voltage fluctuation | ±10% of rated voltage | |
| | Coil insulation type | Class B or equivalent | |
| | Power consumption (Current) | 24 VDC DC 0.35 W (15 mA) | |

*1: Use dry air to prevent condensation when operating at low temperatures.

*2: Valves with the external pilot specifications have a pilot EXH with individual exhaust specifications.



*3: Impact resistance: No malfunction occurred when it is tested with a drop tester in the axial direction and at the right angles to the main valve and armature in both energized and deenergized states every once for each condition.

Vibration resistance: No malfunction occurred in a one-sweep test between 8.3 and 2000 Hz. Test was performed at both energized and de-energized states in the axial direction and at the right angles to the main valve and armature.

Manifold Specifications

Manifold Specifications

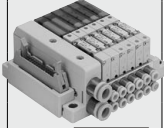
Model

| Base model | | Piping specifications | | Type of connection | Applicable stations ^{*1} | 5-station weight [g] ^{*3} | Addition per station [g] ^{*3} |
|---|------------------|---|--|--|-----------------------------------|------------------------------------|--|
| | | Port size | | | | | |
| | | 1(P), 3(R) | 4(A), 2(B) | | | | |
| Slim compact Bar base  Page 653 | SS0751-□□□□ | C6 (ø6) C8 (ø8) N7 (ø1/4") N9 (ø5/16") Option (Direct EXH outlet with built-in silencer) | C2 (ø2) C3 (ø3.2) C4 (ø4) N1 (ø1/8") N3 (ø5/32") | S kit: Serial transmission (EX510) | Max. 16 stations | 270 ^{*2} | 19 ^{*5} |
| | | | | S kit: Serial transmission (EX180) | Max. 32 stations | 230 ^{*2} | 17 |
| | | | | F kit: D-sub connector | Max. 24 stations | 185 | 17 |
| | | | | P kit: Flat ribbon cable | Max. 24 stations | 181 | 17 |
| Plug-in type Stacking base  Page 675 | SS0750-□□□□ | C6 (ø6) C8 (ø8) N7 (ø1/4") N9 (ø5/16") Option (Direct EXH outlet with built-in silencer) | C2 (ø2) C3 (ø3.2) C4 (ø4) N1 (ø1/8") N3 (ø5/32") | S kit: Serial transmission (EX500) | Max. 16 stations | 260 ^{*2} | 20 |
| | | | | S kit: Serial transmission (EX250/260/600) | Max. 24 stations | 260 ^{*2} | 20 |
| | | | | F kit: D-sub connector | Max. 24 stations | 330 | 20 |
| | | | | P kit: Flat ribbon cable | Max. 24 stations | 325 | 20 |
| | | | | T kit: Terminal block box | Max. 20 stations | 660 | 20 |
| | | | | L kit: Lead wire | Max. 24 stations | 455 ^{*4} | 20 |
| M kit: Circular connector | Max. 24 stations | 390 | 20 | | | | |

*1: Maximum stations in the case of mixed single and double wiring (special wiring specifications)

*2: Differs depending on the serial unit type.

*3: Weight excluding valve. Refer to page 650 for valve weight.

*4: Weight with lead wire length 0.6 m

*5: Including DIN rail weight

SJ

SY

SY

S0700

S0700

S0700 Series

Cylinder Speed Chart

| Applicable cylinder speed | Applicable cylinder | | | | | | | |
|---------------------------|---------------------|-----|-----|-----|-----|-----|-----|-----|
| | ø6 | ø10 | ø16 | ø20 | ø25 | ø32 | ø40 | ø50 |
| 100 mm/s or less | | | | | | | ● | |
| 300 mm/s or less | | | | | ● | | | |
| 500 mm/s or less | ● | | | | | | | |

[Common conditions]

- Pressure: 0.5 MPa
- Piping length: 1 m
- Load ratio: 50%
- Stroke: 200 mm

*: Use as a guide for selection.

Please confirm the actual conditions with SMC Model Selection Software.

Symbol

| Model | Type of actuation | Symbol |
|----------------|--|--------|
| S0710 S0711 | 2-position single | |
| S0720 S0721 | 2-position double | |
| S07A0 S07A1 | 4-position dual 3-port N.C. + N.C. (Exhaust center) | |
| S07B0 S07B1 | 4-position dual 3-port N.O. + N.O. (Pressure center) | |
| S07C0 S07C1 | 4-position dual 3-port N.C. + N.O. | |

Slim Compact Bar Base

Serial Transmission

S Kit



SJ

SY

SY

S0700

S0700

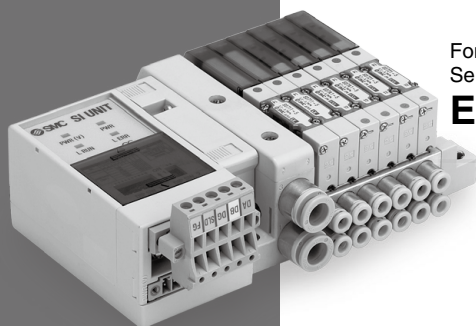

For Output
Serial Transmission System

EX180

→ Page 654

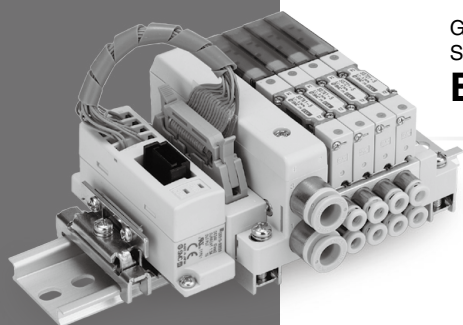

Gateway-type
Serial Transmission System

EX510

→ Page 656



S0700 Series Slim Compact Bar Base

Kit (Serial Transmission) EX180 (For Output) Serial Transmission System



How to Order Manifold

SS0751 - 08 C4 C8 SD V2

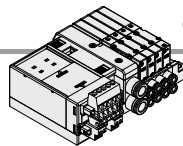

Stations

| Symbol | Stations |
|------------------|-------------|
| 02 | 2 stations |
| ⋮ | ⋮ |
| 32 ^{*1} | 32 stations |

*1: The maximum number of stations will be different depending on the wiring specifications.

Cylinder port size

| Symbol | Port size | |
|--------|-------------------------------|--------|
| C2 | With ø2 One-touch fitting | Metric |
| C3 | With ø3.2 One-touch fitting | |
| C4 | With ø4 One-touch fitting | |
| N1 | With ø1/8" One-touch fitting | Inch |
| N3 | With ø5/32" One-touch fitting | |

P, R port size

| Symbol | Port size | |
|--------|-------------------------------|--------|
| C6 | With ø6 One-touch fitting | Metric |
| C8 | With ø8 One-touch fitting | |
| N7 | With ø1/4" One-touch fitting | Inch |
| N9 | With ø5/16" One-touch fitting | |

*: If an inch size cylinder port is selected, select inch size piping connections for the P and R ports as well.

Option

| Symbol | Specifications |
|-----------------|--|
| Nil | None |
| D | With DIN rail (Rail length: Standard) |
| D0 | Without DIN rail (With bracket) |
| D□ | With DIN rail Designated length (□: Station) |
| K ⁻¹ | Special wiring specifications (Except double wiring) |
| R ⁻² | External pilot |
| S | Built-in silencer |

- *1: Indicate the wiring specifications for mixed single and double wirings.
- *2: For details, refer to page 718.
- *: When two or more options are specified, indicate them alphabetically.
Example) -KRS
- *: For manifold optional parts, refer to pages 718 to 724.
- *: For manifold exploded view, refer to page 672.

SI Unit Part No.

| Symbol | Component module/ Communication connector | Common specification | SI unit part no. | Output stations |
|--------|---|------------------------------|------------------|-----------------------|
| V2 | CC-Link (32 points) | NPN output (Positive common) | EX180-SMJ3 | Max. 32 ^{*1} |
| V2N | T-branch type | PNP output (Negative common) | EX180-SMJ5 | |
| V2A | CC-Link (32 points) | NPN output (Positive common) | EX180-SMJ3A | |
| V2AN | Straight type | PNP output (Negative common) | EX180-SMJ5A | Max. 32 ^{*1} |
| Q2 | DeviceNet® (32 points) | NPN output (Positive common) | EX180-SDN3 | |
| Q2N | T-branch type | PNP output (Negative common) | EX180-SDN5 | |
| Q2A | DeviceNet® (32 points) | NPN output (Positive common) | EX180-SDN3A | Max. 16 ^{*1} |
| Q2AN | Straight type | PNP output (Negative common) | EX180-SDN5A | |
| Q3 | DeviceNet® (16 points) | NPN output (Positive common) | EX180-SDN4 | |
| Q3N | T-branch type | PNP output (Negative common) | EX180-SDN6 | Max. 16 ^{*1} |
| Q3A | DeviceNet® (16 points) | NPN output (Positive common) | EX180-SDN4A | |
| Q3AN | Straight type | PNP output (Negative common) | EX180-SDN6A | |

*1: Single wiring

Kit type

| Symbol | Specifications |
|--------|------------------------|
| 0 | Without SI unit |
| V2 | CC-Link (32 points) |
| Q2 | DeviceNet® (32 points) |
| Q3 | DeviceNet® (16 points) |

*: Please contact SMC for SI unit specifications.

- *: The maximum number of stations is determined by the total number of solenoids.
For mixed single and double wirings, enter -K to the order code options.
- *: For the S0700 series, SI unit models EX180-SDN1, EX180-SDN2, or EX180-SMJ1 cannot be selected as S kit (SD□□, SDV2).

| Type of actuation | Single | Double, Dual 3-port |
|---------------------|--------|---------------------|
| Number of solenoids | 1 | 2 |

How to Order Manifold Assembly

Example Serial transmission kit

Specify the part numbers for valves and options together beneath the manifold base part number.

SS0751-08C4C8SD02 ... 1 set - Manifold base part no.
 * S0711-5 ... 3 sets - Valve part no. (Stations 1 to 3)
 * S0721-5 ... 2 sets - Valve part no. (Stations 4 to 5)
 * S07A1-5 ... 2 sets - Valve part no. (Stations 6 to 7)
 * SS0700-10A-3 ... 1 set - Blanking plate part no. (Station 8)

Prefix the asterisk to the part numbers of the solenoid valve etc. Write sequentially from the 1st station on the D side. When part numbers written collectively are complicated, specify on the manifold specification sheet.

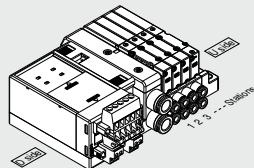

How to Order Valves

S07 1 1 - 5

Type of actuation

| Symbol | Specifications |
|--------|--|
| 1 | 2-position single |
| 2 | 2-position double |
| A | 4-position dual 3-port (N.C. + N.C.) [Exhaust center] |
| B | 4-position dual 3-port (N.O. + N.O.) [Pressure center] |
| C | 4-position dual 3-port (N.C. + N.O.) |

*: For symbol, refer to page 652.

Voltage: 24 VDC

Function

| Symbol | Specifications |
|--------|------------------------------|
| Nil | Standard |
| R | External pilot ^{*1} |

*1: Not compatible with dual 3-port valves. The 3(R) port is open to the atmosphere. (Cannot be used for applying pressure or vacuum)

Base mounted plug-in

Slim Compact Bar Base

EX180 (For Output) Serial Transmission System **S0700 Series**

SJ

SY

SY

S0700

S0700

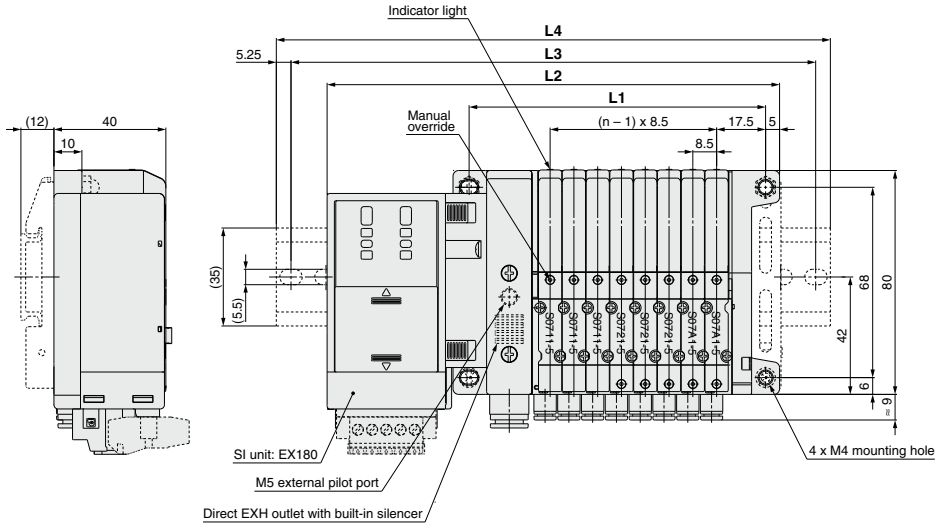

D side Stations ① ② ③ ④ ⑤ ⑥ ⑦ ⑧ ⑨ U side

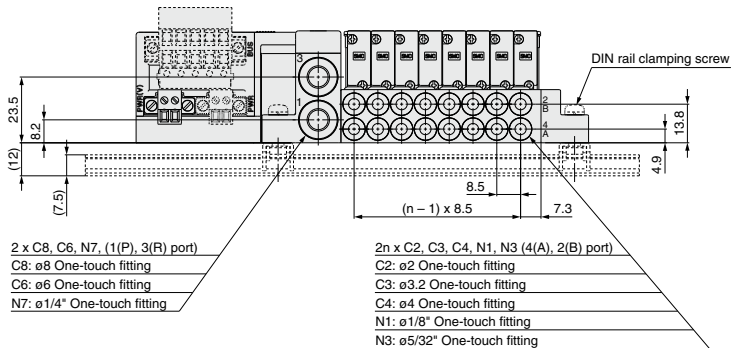

*: Dotted line indicates DIN rail mounting bracket (-D).

Dimensions

Formula $L1 = 8.5n + 38$, $L2 = 8.5n + 93.7$ n: Station (Maximum 32 stations)

| L \ n | 2 | 3 | 4 | 5 | 6 | 7 | 8 | 9 | 10 | 11 | 12 | 13 | 14 | 15 | 16 | 17 | 18 |
|-----------|-------|-------|-------|-------|-------|-------|-------|-------|-------|-------|-------|-------|-------|-------|-------|-------|-------|
| L1 | 55 | 63.5 | 72 | 80.5 | 89 | 97.5 | 106 | 114.5 | 123 | 131.5 | 140 | 148.5 | 157 | 165.5 | 174 | 182.5 | 191 |
| L2 | 110.7 | 119.2 | 127.7 | 136.2 | 144.7 | 153.2 | 161.7 | 170.2 | 178.7 | 187.2 | 195.7 | 204.2 | 212.7 | 221.2 | 229.7 | 238.2 | 246.7 |
| L3 | 137.5 | 150 | 150 | 162.5 | 175 | 175 | 187.5 | 200 | 200 | 212.5 | 225 | 225 | 237.5 | 250 | 250 | 262.5 | 275 |
| L4 | 148 | 160.5 | 160.5 | 173 | 185.5 | 185.5 | 198 | 210.5 | 210.5 | 223 | 235.5 | 235.5 | 248 | 260.5 | 260.5 | 273 | 285.5 |

| L \ n | 19 | 20 | 21 | 22 | 23 | 24 | 25 | 26 | 27 | 28 | 29 | 30 | 31 | 32 |
|-----------|-------|-------|-------|-------|-------|-------|-------|-------|-------|-------|-------|-------|-------|-------|
| L1 | 199.5 | 208 | 216.5 | 225 | 233.5 | 242 | 250.5 | 259 | 267.5 | 276 | 284.5 | 293 | 301.5 | 310 |
| L2 | 255.2 | 263.7 | 272.2 | 280.7 | 289.2 | 297.7 | 306.2 | 314.7 | 323.2 | 331.7 | 340.2 | 348.7 | 357.2 | 365.7 |
| L3 | 275 | 287.5 | 300 | 312.5 | 312.5 | 325 | 337.5 | 337.5 | 350 | 362.5 | 362.5 | 375 | 387.5 | 387.5 |
| L4 | 285.5 | 298 | 310.5 | 323 | 323 | 335.5 | 348 | 348 | 360.5 | 373 | 373 | 385.5 | 398 | 398 |



S0700 Series Slim Compact Bar Base

Kit (Serial Transmission) EX510 Gateway-type Serial Transmission System

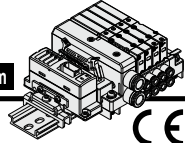

How to Order Manifold

SS0751 - 08 C4 C8 SB -

Stations

| Symbol | Stations |
|------------------|-------------|
| 02 | 2 stations |
| ⋮ | ⋮ |
| 16 ⁻¹ | 16 stations |

*1: The maximum number of stations will be different depending on the wiring specifications.

Cylinder port size

| Symbol | Port size | |
|--------|-------------------------------|--------|
| C2 | With ø2 One-touch fitting | Metric |
| C3 | With ø3.2 One-touch fitting | |
| C4 | With ø4 One-touch fitting | Inch |
| N1 | With ø1/8" One-touch fitting | |
| N3 | With ø5/32" One-touch fitting | |

| Standard station | Max. number of stations for special wiring specifications | Max. number of solenoids |
|------------------|---|--------------------------|
| 1 to 8 stations | 16 stations | 16 |

| Type of actuation | Single | Double, Dual 3-port |
|---------------------|--------|---------------------|
| Number of solenoids | 1 | 2 |

P, R port size

| Symbol | Port size | |
|--------|-------------------------------|--------|
| C6 | With ø6 One-touch fitting | Metric |
| C8 | With ø8 One-touch fitting | |
| N7 | With ø1/4" One-touch fitting | Inch |
| N9 | With ø5/16" One-touch fitting | |

*: If an inch size cylinder port is selected, select inch size piping connections for the P and R ports as well.

Option

| Symbol | Specifications |
|-----------------|--|
| Nil | None |
| K ⁻¹ | Special wiring specifications (Except double wiring) |
| R ⁻² | External pilot |
| S | Built-in silencer |

*1: Indicate the wiring specifications for mixed single and double wirings.

*2: For details, refer to page 718.

*: When two or more options are specified, indicate them alphabetically. Example) -KRS

*: For manifold optional parts, refer to pages 718 to 724.

*: For manifold exploded view, refer to page 672.

SI unit output polarity

| Symbol | Specifications |
|--------|-----------------|
| Nil | Positive common |
| N | Negative common |

S kit

EX510 serial wiring

*: For SI unit part number, refer to page 673.

Refer to pages 878 to 906 and the Operation Manual for the details of the EX510 Gateway-type Serial Transmission System. Please download the Operation Manual via our website, <http://www.smcworld.com>

How to Order Valves

S07 1 1 - 5

Type of actuation

| Symbol | Specifications |
|--------|--|
| 1 | 2-position single |
| 2 | 2-position double |
| A | 4-position dual 3-port (N.C. + N.C.) [Exhaust center] |
| B | 4-position dual 3-port (N.O. + N.O.) [Pressure center] |
| C | 4-position dual 3-port (N.C. + N.O.) |

*: For symbol, refer to page 652.

Voltage: 24 VDC

Function

| Symbol | Specifications |
|--------|------------------------------|
| Nil | Standard |
| R | External pilot ^{*1} |

*1: Not compatible with dual 3-port valves.

The 3(R) port is open to the atmosphere. (Cannot be used for applying pressure or vacuum)

Base mounted plug-in

How to Order Manifold Assembly

Example Serial transmission kit

Specify the part numbers for valves and options together beneath the manifold base part number.

SS0751-08C4C8SB ... 1 set - Manifold base part no.
 * S0711-5 3 sets - Valve part no. (Stations 1 to 3)
 * S0721-5 2 sets - Valve part no. (Stations 4 to 5)
 * S07A1-5 2 sets - Valve part no. (Stations 6 to 7)
 * SS0700-10A-3 1 set - Blanking plate part no. (Station 8)

Write sequentially from the 1st station on the D side. When part numbers written collectively are complicated, specify on the manifold specification sheet.

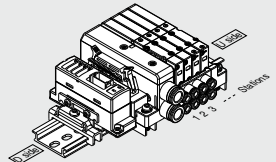

Slim Compact Bar Base
EX510 Gateway-type Serial Transmission System ***S0700 Series***

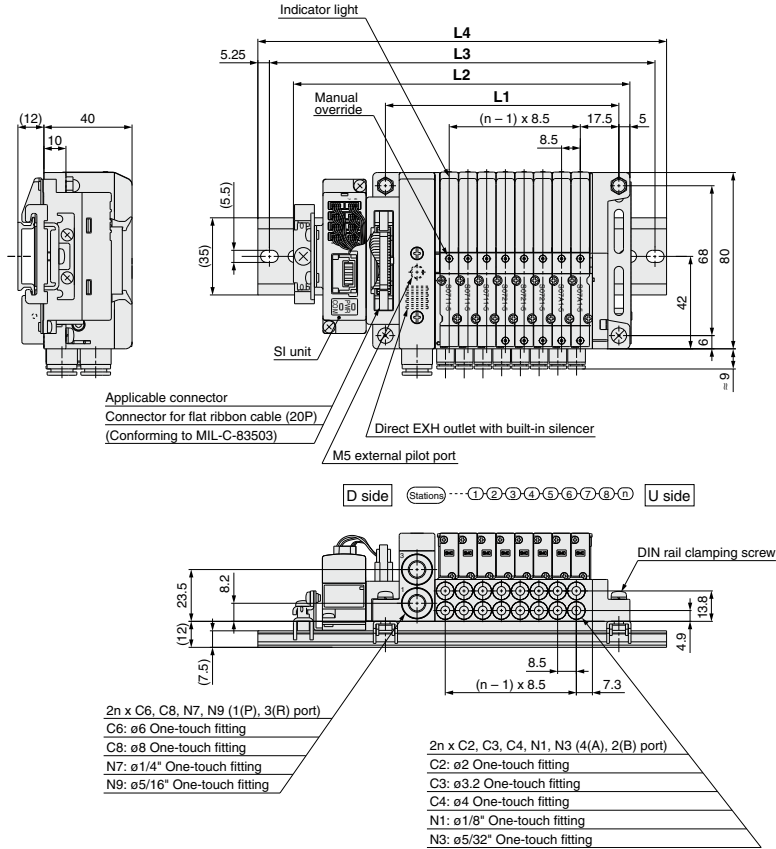

Dimensions

Formula L1 = 8.5n + 38, L2 = 8.5n + 84.7 n: Station (Maximum 16 stations)

| L \ n | 2 | 3 | 4 | 5 | 6 | 7 | 8 | 9 | 10 | 11 | 12 | 13 | 14 | 15 | 16 |
|-----------|-------|-------|-------|-------|-------|-------|-------|-------|-------|-------|-------|-------|-------|-------|-------|
| L1 | 55 | 63.5 | 72 | 80.5 | 89 | 97.5 | 106 | 114.5 | 123 | 131.5 | 140 | 148.5 | 157 | 165.5 | 174 |
| L2 | 101.7 | 110.2 | 118.7 | 127.2 | 135.7 | 144.2 | 152.7 | 161.2 | 169.7 | 178.2 | 186.7 | 195.2 | 203.7 | 212.2 | 220.7 |
| L3 | 125 | 137.5 | 150 | 162.5 | 175 | 187.5 | 200 | 212.5 | 225 | 237.5 | 250 | 262.5 | 275 | 287.5 | 300 |
| L4 | 135.5 | 148 | 160.5 | 173 | 185.5 | 198 | 210.5 | 223 | 235.5 | 248 | 260.5 | 273 | 285.5 | 298 | 310.5 |

Slim Compact Bar Base

D-sub Connector

F Kit



SJ

SY

SY

S0700

S0700

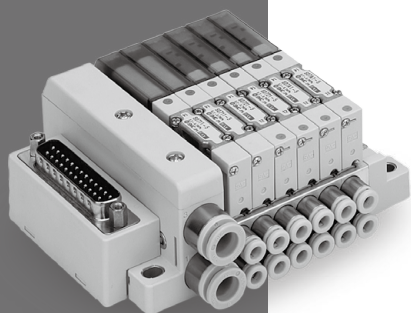

MIL Standard

- 25 pins
- Cable length: 1.5 m, 3 m, 5 m

Page 660

F S0700 Series Slim Compact Bar Base Kit (D-sub Connector)

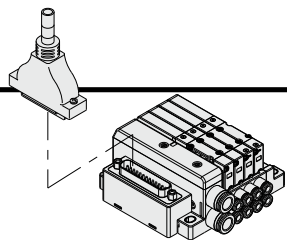

- The D-sub connector reduces installation labor for electrical connections.
- Using the D-sub connector (25P), conforming to MIL standard permits the use of connectors put on the market and gives a wide interchangeability.

Electrical Wiring Specifications

D-sub connector

As the standard electrical wiring specifications, double wiring (connected to SOL. A and SOL. B) is adopted for the internal wiring of each station for 12 stations or less, regardless of valve and option types. Mixed single and double wiring is available as an option. For details, refer to Special Wiring Specifications (Option) below.

D-sub connector assembly
wire color (AXT100-DS25-015-030-050)

| Terminal no. | Polarity | Lead wire color | Dot marking |
|--------------|--------------|-----------------|-------------|
| Station 1 | SOL.A 1 (-) | Black | None |
| | SOL.B 14 (+) | Yellow | Black |
| Station 2 | SOL.A 2 (-) | Brown | None |
| | SOL.B 15 (+) | Pink | Black |
| Station 3 | SOL.A 3 (-) | Red | None |
| | SOL.B 16 (+) | Blue | White |
| Station 4 | SOL.A 4 (-) | Orange | None |
| | SOL.B 17 (+) | Purple | None |
| Station 5 | SOL.A 5 (-) | Yellow | None |
| | SOL.B 18 (+) | Gray | None |
| Station 6 | SOL.A 6 (-) | Pink | None |
| | SOL.B 19 (+) | Orange | Black |
| Station 7 | SOL.A 7 (-) | Blue | None |
| | SOL.B 20 (+) | Red | White |
| Station 8 | SOL.A 8 (-) | Purple | White |
| | SOL.B 21 (+) | Brown | White |
| Station 9 | SOL.A 9 (-) | Gray | Black |
| | SOL.B 22 (+) | Pink | Red |
| Station 10 | SOL.A 10 (-) | White | Black |
| | SOL.B 23 (+) | Gray | Red |
| Station 11 | SOL.A 11 (-) | White | Red |
| | SOL.B 24 (+) | Black | White |
| Station 12 | SOL.A 12 (-) | Yellow | Red |
| | SOL.B 25 (-) | White | None |
| | COM. 13 (+) | Orange | Red |

Positive COM Negative COM

*1: Mounting valve has no polarity. It can also be used as a negative common.

Special Wiring Specifications (Option) [-K]

Mixed single and double wiring are available as an option. The maximum number of manifold stations is determined by the number of solenoids. Count one point for a single solenoid type and two points for a double solenoid type. The total number of solenoids (points) must not exceed 24.

1. How to Order valves
Indicate an option symbol, -K, for the manifold part number and be sure to specify the mounting position and number of stations of the single and double wiring on the manifold specification sheet.

2. Wiring specifications
Connector terminal numbers are connected from solenoid station 1 on the A side in the order indicated by the arrows without skipping any terminal numbers.

Cable Assembly

AXT100-DS25-030
015
050

(The D-sub connector cable assemblies can be ordered with manifolds.)
Refer to How to Order Manifold.

D-sub connector cable assembly

Wire Color by Terminal No.

| Terminal no. | Lead wire color | Dot marking |
|--------------|-----------------|-------------|
| 1 | Black | None |
| 2 | Brown | None |
| 3 | Red | None |
| 4 | Orange | None |
| 5 | Yellow | None |
| 6 | Pink | None |
| 7 | Blue | None |
| 8 | Purple | White |
| 9 | Gray | Black |
| 10 | White | Black |
| 11 | White | Red |
| 12 | Yellow | Red |
| 13 | Orange | Red |
| 14 | Yellow | Black |
| 15 | Pink | Black |
| 16 | Blue | White |
| 17 | Purple | None |
| 18 | Gray | None |
| 19 | Orange | Black |
| 20 | Red | White |
| 21 | Brown | White |
| 22 | Pink | Red |
| 23 | Gray | Red |
| 24 | Black | White |
| 25 | White | None |

D-sub Connector Cable Assembly (Option)

| Cable length (L) | Assembly part no. | Note |
|------------------|-------------------|--------------------------------------|
| 1.5 m | AXT100-DS25-015 | |
| 3 m | AXT100-DS25-030 | Cable 0.3 mm ² x 25 cores |
| 5 m | AXT100-DS25-050 | |

*: For other commercial connectors, use a 25-pin type with female connector conforming to MIL-C-24308.
*: Cannot be used for movable wiring.

Connector manufacturers' example

| Item | Property |
|-----------------------------------|------------|
| Conductor resistance Ω/km, 20°C | 65 or less |
| Voltage limit V, 1 min. AC | 1000 |
| Insulation resistance MΩ/km, 20°C | 5 or more |

*: The minimum bending inner radius of D-sub connector cable is 20 mm.



How to Order Manifold

SS0751 - 08 C4 C8 FD1 -

Stations

| Symbol | Stations |
|--------|-------------|
| 02 | 2 stations |
| ⋮ | ⋮ |
| 24*1 | 24 stations |

*1: The maximum number of stations will be different depending on the wiring specifications.

Cylinder port size

| Symbol | Port size | |
|--------|-------------------------------|--------|
| C2 | With ø2 One-touch fitting | Metric |
| C3 | With ø3.2 One-touch fitting | |
| C4 | With ø4 One-touch fitting | |
| N1 | With ø1/8" One-touch fitting | Inch |
| N3 | With ø5/32" One-touch fitting | |

P, R port size

| Symbol | Port size | |
|--------|-------------------------------|--------|
| C6 | With ø6 One-touch fitting | Metric |
| C8 | With ø8 One-touch fitting | |
| N7 | With ø1/4" One-touch fitting | |
| N9 | With ø5/16" One-touch fitting | Inch |

*: If an inch size cylinder port is selected, select inch size piping connections for the P and R ports as well.

Option

| Symbol | Specifications |
|--------|--|
| Nil | None |
| D | With DIN rail (Rail length: Standard) |
| D0 | Without DIN rail (With bracket) |
| D□*1 | With DIN rail Designated length (□: Station) |
| K*2 | Special wiring specifications (Except double wiring) |
| R*3 | External pilot |
| S | Built-in silencer |

- *1: The available number of stations is larger than the number of manifold stations.
- *2: Indicate the wiring specifications for mixed single and double wirings.
- *3: For details, refer to page 718.
- *: When two or more options are specified, indicate them alphabetically. Example) -DKN
- *: For manifold optional parts, refer to pages 718 to 724.
- *: For manifold exploded view, refer to page 672.

Kit type/Cable length

| Kit type | Symbol | Specifications | Standard station | Max. number of stations for special wiring specifications | Max. number of solenoids |
|----------|--------|---|------------------|---|--------------------------|
| F kit | FD0 | D-sub connector (25P), without cable | 2 to 12 stations | 24 stations | 24 |
| | FD1 | D-sub connector (25P), with 1.5 m cable | | | |
| | FD2 | D-sub connector (25P), with 3.0 m cable | | | |
| | FD3 | D-sub connector (25P), with 5.0 m cable | | | |

*: The maximum number of stations is determined by the total number of solenoids. For mixed single and double wirings, enter -K to the order code options.

| Type of actuation | Single | Double, Dual 3-port |
|---------------------|--------|---------------------|
| Number of solenoids | 1 | 2 |

How to Order Valves

S07 1 1 - 5

Type of actuation

| Symbol | Specifications |
|--------|--|
| 1 | 2-position single |
| 2 | 2-position double |
| A | 4-position dual 3-port (N.C. + N.C.) [Exhaust center] |
| B | 4-position dual 3-port (N.O. + N.O.) [Pressure center] |
| C | 4-position dual 3-port (N.C. + N.O.) |

*: For symbol, refer to page 652.

Voltage

| Symbol | Specifications |
|--------|----------------|
| 5 | 24 VDC |
| 6 | 12 VDC |

Function

| Symbol | Specifications |
|--------|------------------|
| Nil | Standard |
| R | External pilot*1 |

*1: Not compatible with dual 3-port valves.

Base mounted plug-in

How to Order Manifold Assembly

Example D-sub connector kit

Specify the part numbers for valves and options together beneath the manifold base part number.

SS0751-08C4C8FD1 ... 1 set - Manifold base part no.
 * S0711-5 3 sets - Valve part no. (Stations 1 to 3)
 * S0721-5 2 sets - Valve part no. (Stations 4 to 5)
 * S07A1-5 2 sets - Valve part no. (Stations 6 to 7)
 * SS0700-10A-3 1 set - Blanking plate part no. (Station 8)

Prefix the asterisk to the part numbers of the solenoid valve etc. Write sequentially from the 1st station on the D side. When part numbers written collectively are complicated, specify on the manifold specification sheet.

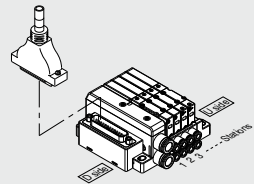

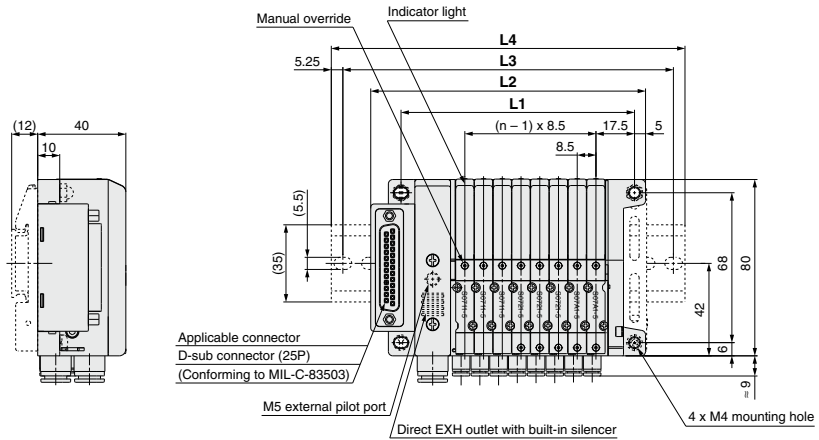
F**S0700 Series**
Kit (D-sub Connector)

D side (Stations) ① ② ③ ④ ⑤ ⑥ ⑦ ⑧ n U side

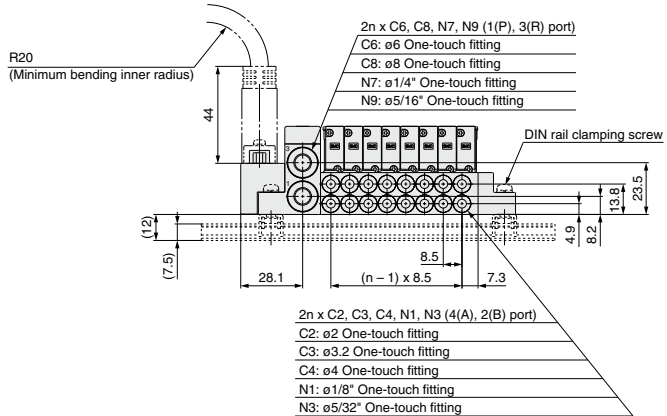
**Dimensions**

Formula L1 = 8.5n + 38, L2 = 8.5n + 56.7 n: Station (Maximum 24 stations)

| L | n | 2 | 3 | 4 | 5 | 6 | 7 | 8 | 9 | 10 | 11 | 12 | 13 | 14 | 15 | 16 | 17 | 18 | 19 | 20 | 21 | 22 | 23 | 24 |
|----|-------|-------|-------|-------|-------|-------|-------|-------|-------|-------|-------|-------|-------|-------|-------|-------|-------|-------|-------|-------|-------|-------|-------|----|
| L1 | 55 | 63.5 | 72 | 80.5 | 89 | 97.5 | 106 | 114.5 | 123 | 131.5 | 140 | 148.5 | 157 | 165.5 | 174 | 182.5 | 191 | 199.5 | 208 | 216.5 | 225 | 233.5 | 242 | |
| L2 | 73.7 | 82.2 | 90.7 | 99.2 | 107.7 | 116.2 | 124.7 | 133.2 | 141.7 | 150.2 | 158.7 | 167.2 | 175.7 | 184.2 | 192.7 | 201.2 | 209.7 | 218.2 | 226.7 | 235.2 | 243.7 | 252.2 | 260.7 | |
| L3 | 100 | 112.5 | 112.5 | 125 | 137.5 | 137.5 | 150 | 162.5 | 162.5 | 175 | 187.5 | 187.5 | 200 | 212.5 | 212.5 | 225 | 237.5 | 237.5 | 250 | 262.5 | 275 | 275 | 287.5 | |
| L4 | 110.5 | 123 | 123 | 135.5 | 148 | 148 | 160.5 | 173 | 173 | 185.5 | 198 | 198 | 210.5 | 223 | 223 | 235.5 | 248 | 248 | 260.5 | 273 | 285.5 | 285.5 | 298 | |

Slim Compact Bar Base

Flat Ribbon Cable

P Kit



SJ

SY

SY

S0700

S0700

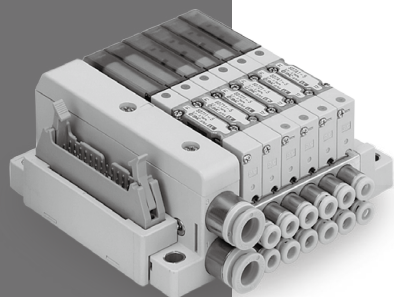

MIL Standard

- 26 pins, 20 pins
- Cable length: 1.5 m, 3 m, 5 m

→ Page 664

P S0700 Series Slim Compact Bar Base Kit (Flat Ribbon Cable)

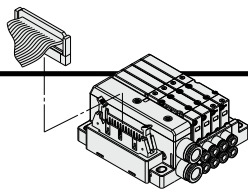

- Flat ribbon cable connector reduces installation labor for electrical connection.
- Using the connector for flat ribbon cable (26P, 20P) conforming to MIL standard permits the use of connectors put on the market and gives a wide interchangeability.

Electrical Wiring Specifications

Flat ribbon cable connector

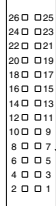

Double wiring (connected to SOL. A and SOL. B) is adopted for the internal wiring of each station, regardless of valve and option types. Mixed single and double wiring is available as an option. For details, refer to Special Wiring Specifications (Option) below.

Connector terminal no.

Triangle mark indicator position

<26P>

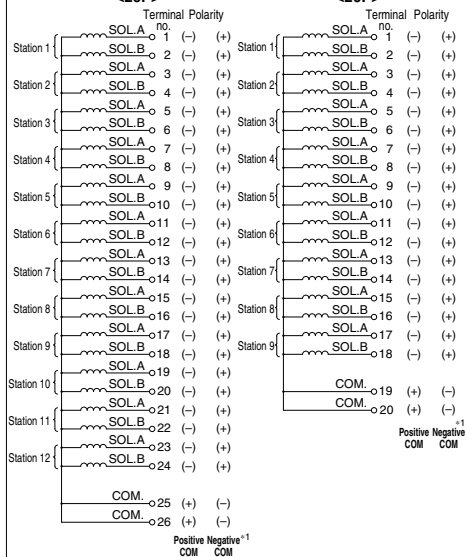

*1: Mounting valve has no polarity. It can also be used as a negative common.

Cable Assembly

AXT100-FC²⁰₂₆¹₃

(Type 26P flat ribbon cable connector assemblies can be ordered with manifolds. Refer to How to Order Manifold.)

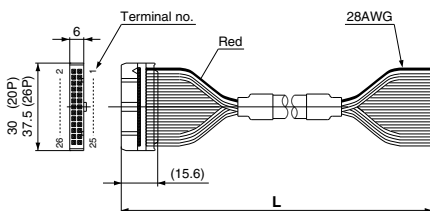

Flat Ribbon Cable Connector Assembly (Option)

| Cable length (L) | Assembly part no. | |
|------------------|-------------------|---------------|
| | 26P | 20P |
| 1.5 m | AXT100-FC26-1 | AXT100-FC20-1 |
| 3 m | AXT100-FC26-2 | AXT100-FC20-2 |
| 5 m | AXT100-FC26-3 | AXT100-FC20-3 |

*: For other commercial connectors, use a 20- or 26-pin type with strain relief conforming to MIL-C-83503.

*: Cannot be used for movable wiring.

Connector manufacturers' example

- HIROSE ELECTRIC CO., LTD.
- 3M Japan Limited
- Fujitsu Limited
- Japan Aviation Electronics Industry, Limited.
- J. S.T. Mfg. Co., Ltd.
- Oki Electric Cable Co., Ltd.

Special Wiring Specifications (Option) [-K]

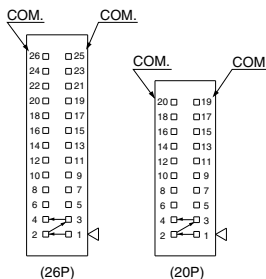

Mixed single and double wiring are available as an option. The maximum number of manifold stations is determined by the number of solenoids. Count one point for a single solenoid type and two points for a double solenoid type. The total number of solenoids (points) must not exceed 24 for 26P, 18 for 20P.

1. How to Order valves
Indicate an option symbol, -K, for the manifold part number and be sure to specify the mounting position and number of stations of the single and double wiring on the manifold specification sheet.

2. Wiring specifications
Connector terminal numbers are connected from solenoid station 1 on the A side in the order indicated by the arrows without skipping any terminal numbers.



How to Order Manifold

SS0751 - 08 C4 C8 PD1 -

Stations

| Symbol | Stations |
|--------|-------------|
| 02 | 2 stations |
| ⋮ | ⋮ |
| 24 | 24 stations |

*: The maximum number of stations will be different depending on the wiring specifications.

Cylinder port size

| Symbol | Port size | |
|--------|-------------------------------|--------|
| C2 | With ø2 One-touch fitting | Metric |
| C3 | With ø3.2 One-touch fitting | |
| C4 | With ø4 One-touch fitting | Inch |
| N1 | With ø1/8" One-touch fitting | |
| N3 | With ø5/32" One-touch fitting | |

P, R port size

| Symbol | Port size | |
|--------|-------------------------------|--------|
| C6 | With ø6 One-touch fitting | Metric |
| C8 | With ø8 One-touch fitting | |
| N7 | With ø1/4" One-touch fitting | Inch |
| N9 | With ø5/16" One-touch fitting | |

*: If an inch size cylinder port is selected, select inch size piping connections for the P and R ports as well.

Option

| Symbol | Specifications |
|--------|--|
| Nil | None |
| D | With DIN rail (Rail length: Standard) |
| D0 | Without DIN rail (With bracket) |
| D□*1 | With DIN rail Designated length (□: Station) |
| K*2 | Special wiring specifications (Except double wiring) |
| R*3 | External pilot |
| S | Built-in silencer |

- *1: The available number of stations is larger than the number of manifold stations.
- *2: Indicate the wiring specifications for mixed single and double wirings.
- *3: For details, refer to page 718.
- *: When two or more options are specified, indicate them alphabetically. Example) -DKR
- *: For manifold optional parts, refer to pages 718 to 724.
- *: For manifold exploded view, refer to page 672.

Kit type/Cable length

| Kit type | Symbol | Specifications | Standard station | Max. number of stations for special wiring specifications | Max. number of solenoids |
|----------|--------|---|------------------|---|--------------------------|
| P kit | PD0 | Flat ribbon cable (26P), without cable | 2 to 12 stations | 24 stations | 24 |
| | PD1 | Flat ribbon cable (26P), with 1.5 m cable | | | |
| | PD2 | Flat ribbon cable (26P), with 3.0 m cable | | | |
| | PD3 | Flat ribbon cable (26P), with 5.0 m cable | 2 to 9 stations | 18 stations | 18 |
| | PDC | Flat ribbon cable (20P), without cable | | | |

*: The maximum number of stations is determined by the total number of solenoids. For mixed single and double wirings, enter -K to the order code options.

| Type of actuation | Single | Double, Dual 3-port |
|---------------------|--------|---------------------|
| Number of solenoids | 1 | 2 |

How to Order Valves

S07 1 1 - 5

Type of actuation

| Symbol | Specifications |
|--------|--|
| 1 | 2-position single |
| 2 | 2-position double |
| A | 4-position dual 3-port (N.C. + N.C.) [Exhaust center] |
| B | 4-position dual 3-port (N.O. + N.O.) [Pressure center] |
| C | 4-position dual 3-port (N.C. + N.O.) |

*: For symbol, refer to page 652.

Voltage

| Symbol | Specifications |
|--------|----------------|
| 5 | 24 VDC |
| 6 | 12 VDC |

Function

| Symbol | Specifications |
|--------|------------------|
| Nil | Standard |
| R | External pilot*1 |

*1: Not compatible with dual 3-port valves. The 3(R) port is open to the atmosphere. (Cannot be used for applying pressure or vacuum)

Base mounted plug-in

How to Order Manifold Assembly

Example Flat ribbon cable kit

Specify the part numbers for valves and options together beneath the manifold base part number.

SS0751-08C4C8PD1 ... 1 set - Manifold base part no.
 * S0711-5 2 sets - Valve part no. (Stations 1 to 3)
 * S0721-5 4 sets - Valve part no. (Stations 4 to 5)
 * S07A1-5 1 set - Valve part no. (Stations 6 to 7)
 * SS0700-10A-3 1 set - Blanking plate part no. (Station 8)

Prefix the asterisk to the part numbers of the solenoid valve etc. Write sequentially from the 1st station on the D side. When part numbers written collectively are complicated, specify on the manifold specification sheet.

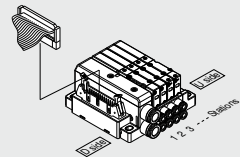



S0700 Series Kit (Flat Ribbon Cable)

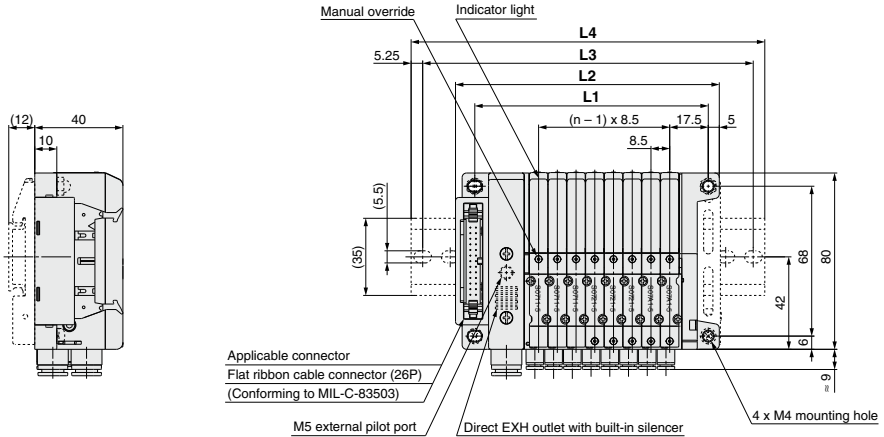

D side Stations ① ② ③ ④ ⑤ ⑥ ⑦ ⑧ U side

Flat ribbon cable connector assembly (26P)
 AXT100-FC26-1: 1.5 m
 AXT100-FC26-2: 3 m
 AXT100-FC26-3: 5 m

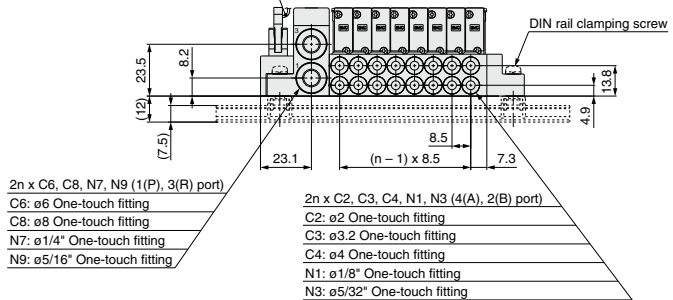

Dimensions

Formula $L1 = 8.5n + 38$, $L2 = 8.5n + 51.7$ n: Station (Maximum 24 stations)

| L \ n | 2 | 3 | 4 | 5 | 6 | 7 | 8 | 9 | 10 | 11 | 12 | 13 | 14 | 15 | 16 | 17 | 18 | 19 | 20 | 21 | 22 | 23 | 24 |
|-------|-------|-------|-------|-------|-------|-------|-------|-------|-------|-------|-------|-------|-------|-------|-------|-------|-------|-------|-------|-------|-------|-------|-------|
| L1 | 55 | 63.5 | 72 | 80.5 | 89 | 97.5 | 106 | 114.5 | 123 | 131.5 | 140 | 148.5 | 157 | 165.5 | 174 | 182.5 | 191 | 199.5 | 208 | 216.5 | 225 | 233.5 | 242 |
| L2 | 68.7 | 77.2 | 85.7 | 94.2 | 102.7 | 111.2 | 119.7 | 128.2 | 136.7 | 145.2 | 153.7 | 162.2 | 170.7 | 179.2 | 187.7 | 196.2 | 204.7 | 213.2 | 221.7 | 230.2 | 238.7 | 247.2 | 255.7 |
| L3 | 100 | 100 | 112.5 | 125 | 137.5 | 150 | 162.5 | 175 | 187.5 | 200 | 200 | 212.5 | 225 | 225 | 225 | 237.5 | 250 | 250 | 262.5 | 275 | 275 | 275 | 275 |
| L4 | 110.5 | 110.5 | 123 | 135.5 | 148 | 148 | 160.5 | 160.5 | 173 | 185.5 | 185.5 | 198 | 210.5 | 210.5 | 223 | 235.5 | 235.5 | 248 | 260.5 | 260.5 | 273 | 285.5 | 285.5 |

Construction

Single: S0711

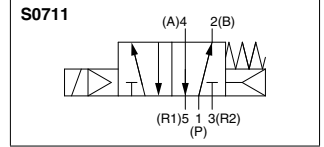
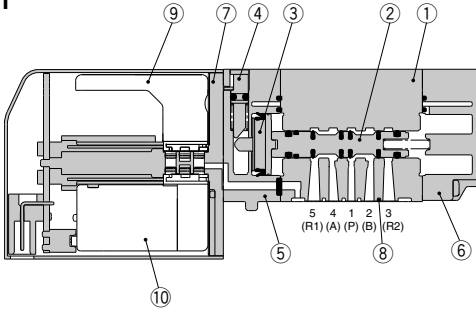

| |
|-------|
| SJ |
| SY |
| SY |
| S0700 |
| S0700 |

Double: S0721

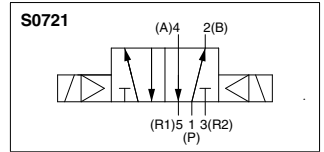
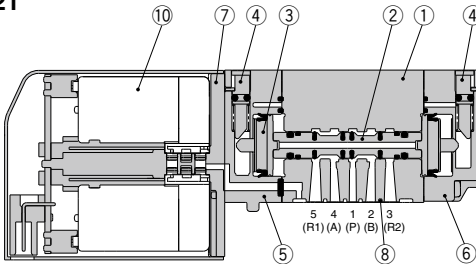

Dual 3-Port: S07B1
A
C

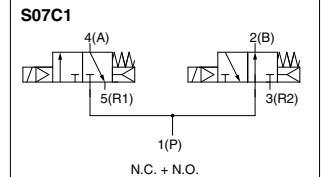
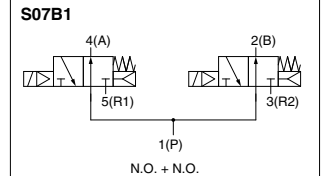
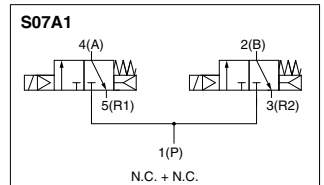
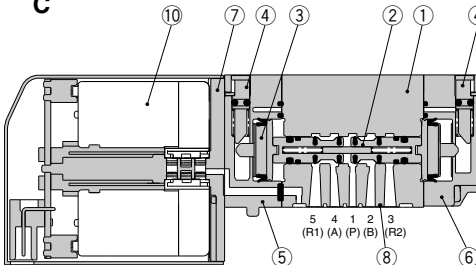

Component Parts

| No. | Description | Material |
|-----|------------------------|-----------------|
| 1 | Body | Zinc die-casted |
| 2 | Spool | Aluminum |
| 3 | Piston | Resin |
| 4 | Manual override | Resin |
| 5 | Adapter plate | Resin |
| 6 | End plate | Resin |
| 7 | Pilot spacer | Resin |
| 8 | Interface gasket | HNBR |
| 9 | Plate | Resin |
| 10 | Pilot valve assembly*1 | — |

*1: Please consult with SMC for pilot valve replacement.

S0700 Series Slim Compact Bar Base Manifold Exploded View

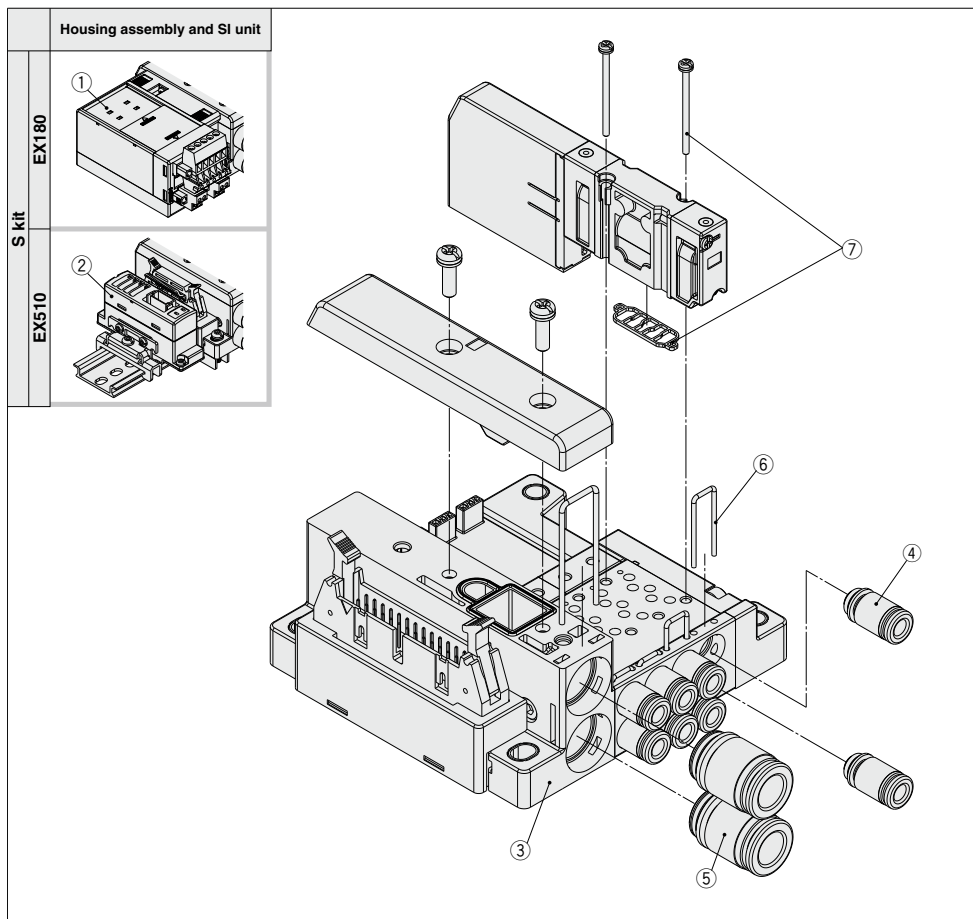

*: It is not possible to increase or decrease the number of stations or change the wiring kit on the slim compact bar base.
To change them, please change the entire base unit.

Manifold Assembly Part No.

| No. | Description | Part no. | Note |
|-----|-------------|--------------------|---|
| ① | SI unit | EX180-SDN3 | DeviceNet® 32 outputs NPN (positive common) T-branch type communication connector |
| | | EX180-SDN3A | DeviceNet® 32 outputs NPN (positive common) Straight type communication connector |
| | | EX180-SDN4 | DeviceNet® 16 outputs NPN (positive common) T-branch type communication connector |
| | | EX180-SDN4A | DeviceNet® 16 outputs NPN (positive common) Straight type communication connector |
| | | EX180-SMJ3 | CC-Link 32 outputs NPN (positive common) T-branch type communication connector |
| | | EX180-SMJ3A | CC-Link 32 outputs NPN (positive common) Straight type communication connector |
| | | EX180-SDN5 | DeviceNet® 32 outputs PNP (negative common) T-branch type communication connector |
| | | EX180-SDN5A | DeviceNet® 32 outputs PNP (negative common) Straight type communication connector |
| | | EX180-SDN6 | DeviceNet® 16 outputs PNP (negative common) T-branch type communication connector |
| | | EX180-SDN6A | DeviceNet® 16 outputs PNP (negative common) Straight type communication connector |
| | | EX180-SMJ5 | CC-Link 32 outputs PNP (negative common) T-branch type communication connector |
| | | EX180-SMJ5A | CC-Link 32 outputs PNP (negative common) Straight type communication connector |
| ② | SI unit | EX510-S002A | NPN (Positive common) |
| | | EX510-S102A | PNP (Negative common) |
| ③ | Base unit | SS0751-□□□□ | Refer to How to Order for each kit. |

SJ
SY
SY
S0700
S0700

④ Fitting assembly part number for cylinder port

VVQ0000-50A-□

◆ Port size

| Symbol | Applicable tube |
|-----------|------------------------|
| C2 | Applicable tube ø2 |
| C3 | Applicable tube ø3 |
| C4 | Applicable tube ø4 |
| N1 | Applicable tube ø1/8" |
| N3 | Applicable tube ø5/32" |

*: Purchasing order is available in units of 10 pieces.

*: For One-touch fittings replacement, refer to Specific Product Precautions 2.

⑤ Fitting assembly part number for P, R port

VVQ1000-51A-□

◆ Port size

| Symbol | Applicable tube |
|-----------|------------------------|
| C6 | Applicable tube ø6 |
| C8 | Applicable tube ø8 |
| N7 | Applicable tube ø1/4" |
| N9 | Applicable tube ø5/16" |

*: Purchasing order is available in units of 10 pieces.

*: For One-touch fittings replacement, refer to Specific Product Precautions 2.

| No. | Description | Part no. |
|-----|-------------|---------------------|
| ⑥ | Clip | SS0700-80A-5 |

*: 1 set includes 10 pieces.

| No. | Description | Part no. |
|-----|---------------|-------------------|
| ⑦ | Gasket, Screw | S0700-GS-3 |

*: 1 set includes 10 pieces. (1 gasket, 2 screws)

Plug-in Type Stacking Base

Serial Transmission

S Kit

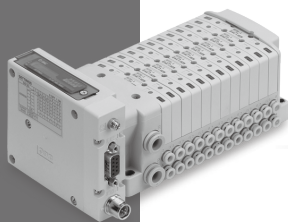

For Output
Serial Transmission System

EX260



SJ

SY

SY

S0700

S0700

→ Page 676

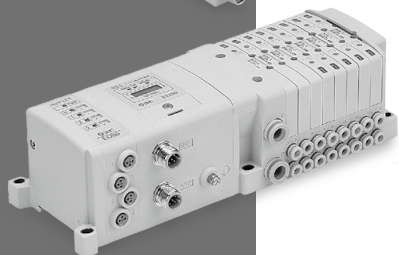

For Input/Output
Serial Transmission System

EX250

→ Page 678

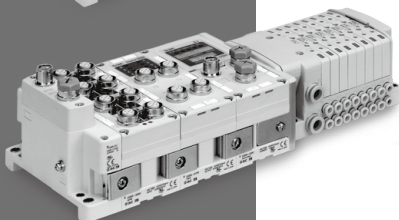

For Input/Output
Serial Transmission System

EX600

→ Page 680



Gateway Decentralized System 2

EX500

→ Page 684

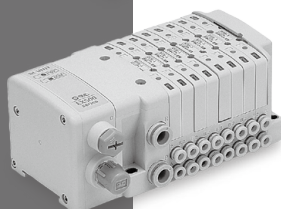

Gateway Decentralized System

EX500

→ Page 686

Plug-in Type

S

S0700 Series Stacking Base

Kit (Serial Transmission) EX260 (For Output) Serial Transmission System

How to Order Manifold

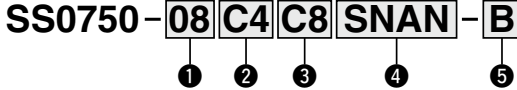
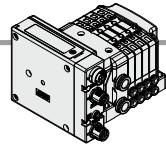

① Stations

In the case of the 32-output SI unit

| Symbol | Stations | Note |
|--------|-------------|--|
| 01 | 1 station | Double wiring*1 |
| : | : | |
| 16 | 16 stations | |
| 01 | 1 station | Specified layout*2 (Available up to 32 solenoids) |
| : | : | |
| 24 | 24 stations | |

In the case of the 16-output SI unit

| Symbol | Stations | Note |
|--------|-------------|--|
| 01 | 1 station | Double wiring*1 |
| : | : | |
| 08 | 8 stations | |
| 01 | 1 station | Specified layout*2 (Available up to 16 solenoids) |
| : | : | |
| 16 | 16 stations | |

*1: Double wiring : single, double, 3-position and 4-position solenoid valves can be used on all manifold stations.

Up to 24 stations due to the structure of the manifold. Please note the maximum number of stations is 24 for single wiring, too.

*2: Specified layout: Indicate the wiring specifications with the manifold specification sheet. (Note that double, 3-position and 4-position valves cannot be used where single solenoid wiring has been specified.)

*: This also includes the number of blanking plate assembly.

② Cylinder port size

| Symbol | Port size | |
|--------|----------------------------------|--------|
| C2 | With ø2 One-touch fitting | Metric |
| C3 | With ø3.2 One-touch fitting | |
| C4 | With ø4 One-touch fitting | |
| CM | Mixed sizes and with port plug*1 | |
| N1 | With ø1/8" One-touch fitting | Inch |
| N3 | With ø5/32" One-touch fitting | |
| NM | Mixed sizes and with port plug*1 | |

*1: Specify Mixed sizes and with port plug on the manifold specification sheet.

③ P, R port size

| Symbol | Port size | |
|--------|-------------------------------|--------|
| C6 | With ø6 One-touch fitting | Metric |
| C7 | With ø8 One-touch fitting | |
| N8 | With ø1/4" One-touch fitting | Inch |
| N9 | With ø5/16" One-touch fitting | |

*: If an inch size cylinder port is selected, select inch size piping connections for the P and R ports as well.

④ SI Unit specifications

(output polarity, protocol, number of outputs, communication connector)

| Symbol (output polarity) | | Protocol | Number of outputs | Communication connector |
|--------------------------|-----------------------|--------------|-------------------|-------------------------|
| Positive common (NPN) | Negative common (NPN) | | | |
| SDO*1 | | | | |
| Without SI unit | | | | |
| SQA | SQAN | DeviceNet® | 32 | M12 |
| SQB | SQAN | | 16 | |
| SNA | SNAN | PROFIBUS | 32 | M12 |
| SNB | SNBN | | 16 | |
| SNC | SNCN | DP | 32 | *4 D-sub |
| SND | SNDN | | 16 | |
| SVA | SVAN | CC-Link | 32 | M12 |
| SVB | SVBN | | 16 | |
| SDA | SDAN | EtherCAT | 32 | M12 |
| SDB | SDBN | | 16 | |
| SFA | SFAN | PROFINET | 32 | M12 |
| SFB | SFBN | | 16 | |
| SEA | SEAN | EtherNet/IP™ | 32 | M12 |
| SEB | SEBN | | 16 | |
| —*3 | SGAN | Ethernet | 32 | M12 |
| —*3 | SGBN | | 16 | |
| —*3 | POWERLINK | 32 | | |

*1: Without SI Unit, the output polarity is decided by the SI unit used.

*2: DIN rail cannot be mounted without SI Unit.

*3: Positive common (NPN) type is not applicable.

*4: IP40 for the D-sub applicable communication connector specification.

*5: The maximum number of stations is determined by the total number of solenoids. For mixed single and double wirings, enter -K to the order code options.

*6: For SI unit part number, refer to page 715.

| Type of actuation | Single | Double, Dual 3-port |
|---------------------|--------|---------------------|
| Number of solenoids | 1 | 2 |

⑤ Option

| Symbol | Specifications |
|--------|--|
| NII | None |
| B*1 | With back pressure check valve (All stations) |
| D | With DIN rail (Rail length: Standard) |
| D0 | Without DIN rail (with bracket) |
| D□*2 | With DIN rail. Designated length (□: Station) |
| K*3 | Special wiring specifications (Except double wiring) |
| N | With name plate |
| R*4 | External pilot |
| S | Built-in silencer |

*1: When installing a back pressure check valve on the required station, enter the part number and specify the station position on the manifold specification sheet.

*2: The available number of stations is larger than the number of manifold stations.

*3: Indicate the wiring specifications for mixed single and double wirings.

*4: For details, refer to page 718.

*: When two or more options are specified, indicate them alphabetically. Example) -BKN

*: For manifold optional parts, refer to pages 718 to 724.

*: For manifold exploded view, refer to page 714.

*: When the SDO (Without SI unit) is specified, -D, -D□ cannot be selected.

Refer to pages 789 to 800 and the Operation Manual for the details of the EX260 Integrated-type (For Output) Serial Transmission System. Please download the Operation Manual via our website, <http://www.smcworld.com>

How to Order Manifold Assembly

Example Serial transmission kit

Specify the part numbers for valves and options together beneath the manifold base part number.

SS0750-04C4C8SNAN-- 1 set - Manifold base part no.
 S0720-5 4 sets - Valve part no. (Stations 1 to 4)

Prefix the asterisk to the part numbers of the solenoid valve etc. Write sequentially from the 1st station on the D side. When part numbers written collectively are complicated, specify on the manifold specification sheet.

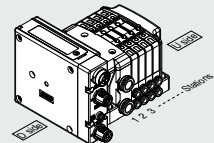

How to Order Valves

S07 1 0 - 5

• Voltage: 24 VDC

• Type of actuation

| Symbol | Specifications |
|--------|--|
| 1 | 2-position single |
| 2 | 2-position double |
| A | 4-position dual 3-port (N.C. + N.C.) [Exhaust center] |
| B | 4-position dual 3-port (N.O. + N.O.) [Pressure center] |
| C | 4-position dual 3-port (N.C. + N.O.) |

*: For symbol, refer to page 652.

• Function

| Symbol | Specifications |
|--------|------------------|
| NII | Standard |
| R | External pilot*1 |

*1: Not compatible with dual 3-port valves. The 3(R) port is open to the atmosphere. (Cannot be used for applying pressure or vacuum)

• Base mounted plug-in

Plug-in Type **Stacking Base**
EX260 (For Output) Serial Transmission System **S0700 Series**

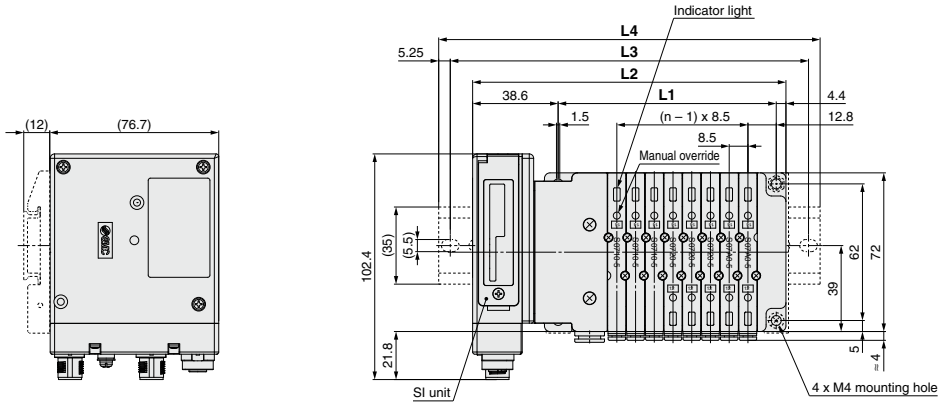

SJ
SY
SY
S0700
S0700

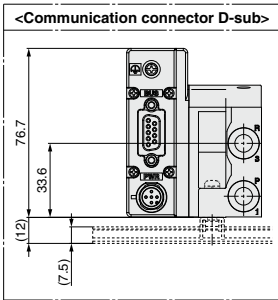

D side (Stations) 1 2 3 4 5 6 7 8 n U side

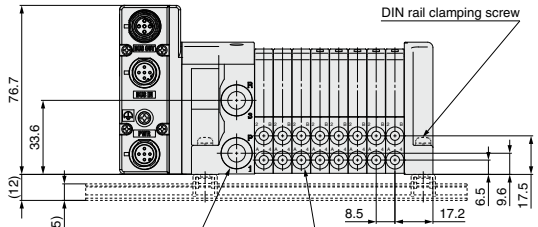

2 x C6, C8, N7, N9 (1(P), 3(R) port)
 C6: ø6 One-touch fitting
 C8: ø8 One-touch fitting
 N7: ø1/4" One-touch fitting
 N9: ø5/16" One-touch fitting

2n x C2, C3, C4, N1, N3 (4(A), 2(B) port)
 C2: ø2 One-touch fitting
 C3: ø3.2 One-touch fitting
 C4: ø4 One-touch fitting
 N1: ø1/8" One-touch fitting
 N3: ø5/32" One-touch fitting

Dimensions

Formula L1 = 8.5n + 31, L2 = 8.5n + 74 n: Station (Maximum 24 stations)

| L \ n | 1 | 2 | 3 | 4 | 5 | 6 | 7 | 8 | 9 | 10 | 11 | 12 | 13 | 14 | 15 | 16 |
|-------|-------|-------|-------|-------|-------|-------|-------|-------|-------|-------|-------|-------|-------|-------|-------|-------|
| L1 | 39.5 | 48 | 56.5 | 65 | 73.5 | 82 | 90.5 | 99 | 107.5 | 116 | 124.5 | 133 | 141.5 | 150 | 158.5 | 167 |
| L2 | 82.5 | 91 | 99.5 | 108 | 116.5 | 125 | 133.5 | 142 | 150.5 | 159 | 167.5 | 176 | 184.5 | 193 | 201.5 | 210 |
| L3 | 112.5 | 112.5 | 125 | 137.5 | 137.5 | 150 | 162.5 | 162.5 | 175 | 187.5 | 187.5 | 200 | 212.5 | 212.5 | 225 | 237.5 |
| L4 | 123 | 123 | 135.5 | 148 | 148 | 160.5 | 173 | 173 | 185.5 | 198 | 198 | 210.5 | 223 | 223 | 235.5 | 248 |

| L \ n | 17 | 18 | 19 | 20 | 21 | 22 | 23 | 24 |
|-------|-------|-------|-------|-------|-------|-------|-------|-------|
| L1 | 175.5 | 184 | 192.5 | 201 | 209.5 | 218 | 226.5 | 235 |
| L2 | 218.5 | 227 | 235.5 | 244 | 252.5 | 261 | 269.5 | 278 |
| L3 | 250 | 250 | 262.5 | 275 | 275 | 287.5 | 300 | 300 |
| L4 | 260.5 | 260.5 | 273 | 285.5 | 285.5 | 298 | 310.5 | 310.5 |

Plug-in Type

S

S0700 Series Stacking Base

Kit (Serial Transmission) EX250 (For Input/Output) Serial Transmission System

PROFIBUS DP compatible products (Kit type/Symbol: SDN) are to be discontinued as of November 2022. As a substitute, please consider the use of an EX600 series product (Kit type/Symbol: SD6N). However, keep in mind that the product specifications, external appearance, etc., differ. For details, please contact your SMC sales representative.

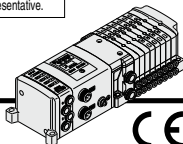

How to Order Manifold

SS0750 - **08** **C4** **C8** **SDQ** **N** **□** **□** **□** - **B**

① ② ③ ④ ⑤ ⑥ ⑦ ⑧ ⑨

1 Stations

| Symbol | Stations |
|-------------------------|-------------|
| 01 | 1 station |
| : | : |
| 24 ^{*1} | 24 stations |

*1: The maximum number of stations will be different depending on the wiring specifications.

2 Cylinder port size

| Symbol | Port size | |
|-----------|--|--------|
| C2 | With ø2 One-touch fitting | Metric |
| C3 | With ø3.2 One-touch fitting | |
| C4 | With ø4 One-touch fitting | |
| CM | Mixed sizes and with port plug ^{*1} | Inch |
| N1 | With ø1/8" One-touch fitting | |
| N3 | With ø5/32" One-touch fitting | |
| NM | Mixed sizes and with port plug ^{*1} | |

*1: Specify "Mixed sizes and with port plug" on the manifold specification sheet.

3 P, R port size

| Symbol | Port size | |
|-----------|-------------------------------|--------|
| C6 | With ø6 One-touch fitting | Metric |
| C8 | With ø8 One-touch fitting | |
| N7 | With ø1/4" One-touch fitting | Inch |
| N9 | With ø5/16" One-touch fitting | |

*1: If an inch size cylinder port is selected, select inch size piping connections for the P and R ports as well.

4 Kit type

| Kit type | Symbol | Specifications | Standard station | Max. number of stations for special wiring specifications | Max. number of solenoids | |
|----------|-----------------------------|----------------|---|---|---------------------------|----|
| | | | | | | |
| S kit | For I/O serial transmission | SD0 | Without SI unit | 1 to 16 stations | 24 ^{*2} stations | 32 |
| | | SDQ | DeviceNet [®] | | | |
| | | SDN | PROFIBUS DP | | | |
| | | SDY | CANopen | | | |
| | | SDZEN | EtherNet/IP™ | | | |
| | | SDTA | AS-Interface 31 slave, 8 in/8 out, 2 isolated common type | | | |
| | | SDTB | AS-Interface 31 slave, 4 in/4 out, 2 isolated common type | 1 to 2 stations | 4 stations | 4 |
| | | SDTC | AS-Interface 31 slave, 8 in/8 out, 1 common type | 1 to 4 stations | 8 stations | 8 |
| | | SDTD | AS-Interface 31 slave, 4 in/4 out, 1 common type | 1 to 2 stations | 4 stations | 4 |

*1: For SI unit part number, refer to page 715.

*2: Up to 24 stations due to the structure of the manifold. Please note the maximum number of stations is 24 for single wiring, too.

*3: The maximum number of stations is determined by the total number of solenoids.

For mixed single and double wirings, enter -K to the order code options.

| Type of actuation | Single | Double, Dual 3-port |
|---------------------|--------|---------------------|
| Number of solenoids | 1 | 2 |

How to Order Valves

S07 **1** **0** **□** - **5**

Type of actuation

| Symbol | Specifications |
|----------|--|
| 1 | 2-position single |
| 2 | 2-position double |
| A | 4-position dual 3-port (N.C. + N.C.) [Exhaust center] |
| B | 4-position dual 3-port (N.O. + N.O.) [Pressure center] |
| C | 4-position dual 3-port (N.C. + N.O.) |

*1: For symbol, refer to page 652.

Function

| Symbol | Specifications |
|------------|------------------------------|
| Nil | Standard |
| R | External pilot ^{*1} |

*1: Not compatible with dual 3-port valves. The (3R) port is open to the atmosphere. (Cannot be used for applying pressure or vacuum)

Base mounted plug-in

5 SI unit output polarity

| SI unit common | EX250 | | | | |
|----------------------------|------------------------|-------------|--------------|---------|--------------|
| | DeviceNet [®] | PROFIBUS DP | AS-Interface | CANopen | EtherNet/IP™ |
| Nil Positive common | — | — | — | — | — |
| N Negative common | ○ | ○ | ○ | ○ | ○ |

*: Without SI unit (SD0), the symbol is nil.

6 Input block (for I/O unit only)

| Symbol | Specifications |
|------------|---------------------------------|
| Nil | SI unit/Input block: None (SD0) |
| 0 | Input block: None |
| 1 | Input block: 1 pc. |
| : | : |
| 8 | Input block: 8 pcs. |

*: Without SI unit (SD0), the symbol is nil.

7 Input block type (for I/O unit only)

| Symbol | Specifications |
|------------|----------------------|
| Nil | Input block: None |
| 1 | M12 2 inputs |
| 2 | M12 4 inputs |
| 3 | M8 4 inputs (3 pins) |

*: Without SI unit (SD0), the symbol is nil.

8 Input block specification (for I/O unit only)

| Symbol | Specifications |
|------------|---|
| Nil | PNP sensor input or without input block |
| N | NPN sensor input |

*: Without SI unit (SD0), the symbol is nil.

9 Option

| Symbol | Specifications |
|---------------|--|
| Nil | None |
| B-1 | With back pressure check valve (All stations) |
| D-5 | With DIN rail (Rail length: Standard) |
| DO-5 | Without DIN rail (With bracket) |
| D□+2-5 | With DIN rail Designated length (□: Station) |
| K-3 | Special wiring specifications (Except double wiring) |
| N | With name plate |
| R-4 | External pilot |
| S | Built-in silencer |

*1: When installing a back pressure check valve on the required station, enter the part number and specify the station position on the manifold specification sheet.

*2: The available number of stations is larger than the number of manifold stations.

*3: Indicate the wiring specifications for mixed single and double wirings.

*4: For details, refer to page 718.

*5: When the SD0 (Without SI unit) is specified, -D, -□ cannot be selected.

*6: When two or more options are specified, indicate them alphabetically. Example) -BKN

*7: For manifold optional parts, refer to pages 718 to 724.

*8: For manifold exploded view, refer to page 714.

Refer to pages 802 to 814 and the Operation Manual for the details of the EX250 Integrated-type (For Output) Serial Transmission System. Please download the Operation Manual via our website, <http://www.smworld.com>

How to Order Manifold Assembly

Example Serial transmission kit

Specify the part numbers for valves and options together beneath the manifold base part number.

SS0750-08C4C8SDQN13N-- 1 set - Manifold base part no.
 * S0710-5 3 sets - Valve part no. (Stations 1 to 3)
 * S0720-5 2 sets - Valve part no. (Stations 4 to 5)
 * S07A0-5 2 sets - Valve part no. (Stations 6 to 7)
 * S0700-10A-1 1 set - Blanking plate part no. (Station 8)

Prefix the asterisk to the part numbers of the solenoid valve etc. Write sequentially from the 1st station on the D side. When part numbers written collectively are complicated, specify on the manifold specification sheet.

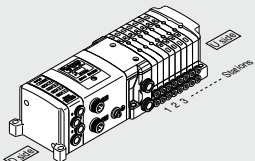

Plug-in Type **Stacking Base** **S0700 Series**
EX250 (For Input/Output) Serial Transmission System

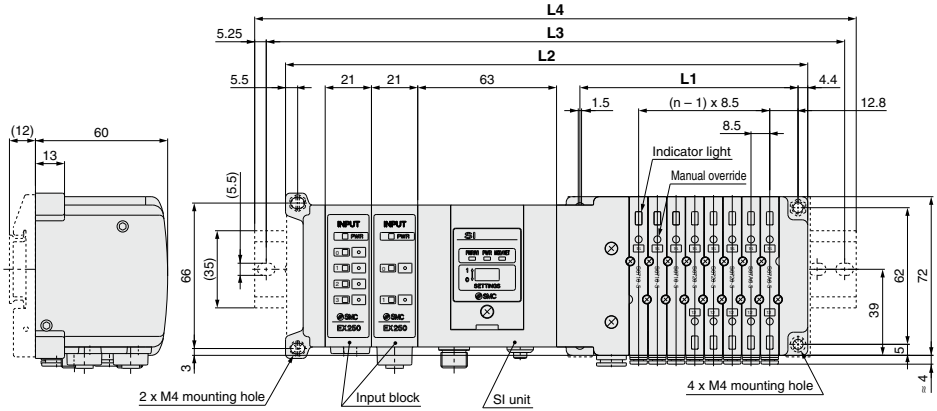

D side Stations --- ① ② ③ ④ ⑤ ⑥ ⑦ ⑧ n U side

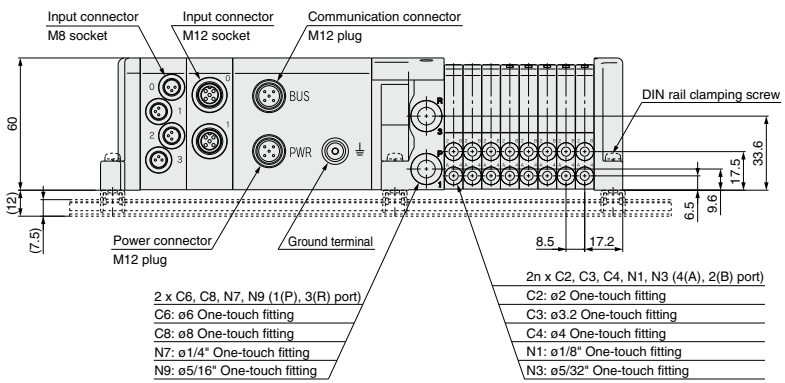

Dimensions Formula $L1 = 8.5n + 31$, $L2 = 8.5n + 169$ (In the case of 2 input blocks, 21 mm is added per 1 pc.). n: Station (Maximum 24 stations)

| L \ n | 2 | 3 | 4 | 5 | 6 | 7 | 8 | 9 | 10 | 11 | 12 | 13 | 14 | 15 | 16 |
|-----------|-------|-------|-------|-------|-------|-------|-------|-------|-------|-------|-------|-------|-------|-------|-------|
| L1 | 48 | 56.5 | 65 | 73.5 | 82 | 90.5 | 99 | 107.5 | 116 | 124.5 | 133 | 141.5 | 150 | 158.5 | 167 |
| L2 | 186 | 194.5 | 203 | 211.5 | 220 | 228.5 | 237 | 245.5 | 254 | 262.5 | 271 | 279.5 | 288 | 296.5 | 305 |
| L3 | 212.5 | 225 | 225 | 237.5 | 250 | 250 | 262.5 | 275 | 275 | 287.5 | 300 | 300 | 312.5 | 325 | 325 |
| L4 | 223 | 235.5 | 235.5 | 248 | 260.5 | 260.5 | 273 | 285.5 | 285.5 | 298 | 310.5 | 310.5 | 323 | 335.5 | 335.5 |

| L \ n | 17 | 18 | 19 | 20 | 21 | 22 | 23 | 24 |
|-----------|-------|-------|-------|-------|-------|-------|-------|-------|
| L1 | 175.5 | 184 | 192.5 | 201 | 209.5 | 218 | 226.5 | 235 |
| L2 | 313.5 | 322 | 330.5 | 339 | 347.5 | 356 | 364.5 | 373 |
| L3 | 337.5 | 350 | 350 | 362.5 | 375 | 387.5 | 387.5 | 400 |
| L4 | 348 | 360.5 | 360.5 | 373 | 385.5 | 398 | 398 | 410.5 |

EtherCAT compatible products (Kit type/Symbol: SD6D) are to be discontinued as of October 2022. As a substitute, please consider the use of an EX260 series product (SI unit specification/Symbol: SDA). However, keep in mind that the product specifications, external appearance, etc., differ. For details, please contact your SMC sales representative.

Plug-in Type

S

S0700 Series Stacking Base

Kit (Serial Transmission) EX600 (For Input/Output) Serial Transmission System (Fieldbus System)

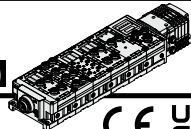

How to Order Manifold

SS0750 - 08 C4 SD6Q 2 N 1 - B

Stations

| Symbol | Stations |
|------------------|-------------|
| 01 | 1 station |
| : | : |
| 24 ^{*1} | 24 stations |

*1: Max. number of stations depends on the wiring specifications.

Cylinder port size

| Symbol | Port size | |
|--------|--|--------|
| C2 | With ø2 One-touch fitting | Metric |
| C3 | With ø3.2 One-touch fitting | |
| C4 | With ø4 One-touch fitting | |
| CM | Mixed sizes and with port plug ^{*1} | |
| N1 | With ø1/8" One-touch fitting | Inch |
| N3 | With ø5/32" One-touch fitting | |
| NM | Mixed sizes and with port plug ^{*1} | |

*1: Indicate the sizes on the manifold specification sheet in the case of CM and NM.

Kit type

| Kit type | Symbol | Specifications | Standard station | Max. number of stations for special wiring specifications | Max. number of solenoids |
|----------|-------------------------------|---|------------------|---|--------------------------|
| S kit | SD60 | Without SI unit | 1 to 16 stations | 24 stations ^{*1} | 32 |
| | SD6Q | DeviceNet [®] | | | |
| | SD6N | PROFIBUS DP | | | |
| | SD6V | CC-Link | | | |
| | SD6F | PROFINET | | | |
| | SD6ZE | EtherNet/IP [™] (1 port) | | | |
| | SD6EA | EtherNet/IP [™] (2 ports) | | | |
| | SD6D | EtherCAT | | | |
| | SD6WE | EtherNet/IP [™] compatible wireless base ^{*2} | | | |
| | SD6WF | PROFINET compatible wireless base ^{*2} | | | |
| SD6WS | Wireless remote ^{*2} | | | | |

*1: Up to 24 stations due to the structure of the manifold. Please note the maximum number of stations is 24 for single wiring, too.

*2: The wireless system is suitable for use only in a country where it is in accordance with the Radio Act and regulations of that country.

*3: Max. station number depends on the number of solenoid valve. Add the option symbol -K when the combination of single wiring and double wiring is specified.

*4: When Without SI unit is specified, valve plate to connect the manifold and SI unit is not mounted. Refer to page 732 for mounting method.

*5: I/O unit cannot be chosen without SI unit.

*6: For SI unit part number, refer to page 715.

| Type of actuation | Single | Double, Dual 3-port |
|---------------------------|--------|---------------------|
| Number of solenoid valves | 1 | 2 |

Option

| Symbol | Specifications |
|--------------------|--|
| Nil | None |
| B ^{*1} | With back pressure check valve (All sta.) |
| D ^{*4} | With DIN rail (Rail length: Standard) |
| DO ^{*4} | With DIN rail bracket (Without rail) |
| D□ ^{*2-4} | With DIN rail length specified (□: Sta.) |
| K ^{*3} | Special wiring specifications (Except double wiring) |
| N | With name plate |
| R ^{*5} | External pilot |
| S | Built-in silencer |

*1: When back pressure check valve is used only for specified station, specify back pressure check valve part number, and specify station number to which the valve is mounted on the manifold specification sheet.

*2: Specified station number shall be longer than manifold station number.

*3: When single wiring and double wiring are mixed, specify wiring type of each station with the manifold specification sheet.

*4: When Without SI unit (SD60) is specified, -D, -D□ cannot be selected.

*5: For details, refer to page 718.

*6: When two or more symbols are specified, indicate them alphabetically. Example) -BKN

I/O unit station number

| Symbol | Specifications |
|--------|----------------|
| Nil | None |
| 1 | 1 station |
| : | : |
| 9 | 9 stations |

*1: Without SI unit, the symbol is nil.

*2: SI unit is not included in I/O unit station number.

*3: When I/O unit is selected, it is shipped separately, and assembled by customer. Refer to the attached operation manual for mounting method.

SI unit output polarity

| Symbol | Specifications |
|--------|-----------------|
| Nil | Positive common |
| N | Negative common |

*1: Without SI unit the symbol is nil.

End plate type

| | |
|-----|--|
| Nil | No end plate |
| 2 | M12 power supply connector, B-coded |
| 3 | 7/8 inch power supply connector |
| 4 | M12 power supply connector IN/OUT, A-coded Pin arrangement 1 |
| 5 | M12 power supply connector IN/OUT, A-coded Pin arrangement 2 |

*1: Without SI Unit, the symbol is nil.

*2: The pin layout for "4" and "5" pin connector is different.

Refer to pages 815 to 843 and the Operation Manual for the details of the EX600 Integrated-type (For Output) Serial Transmission System. Please download the Operation Manual via our website, <http://www.smcworld.com>

How to Order Manifold Assembly (Example)

Example

Serial transmission kit

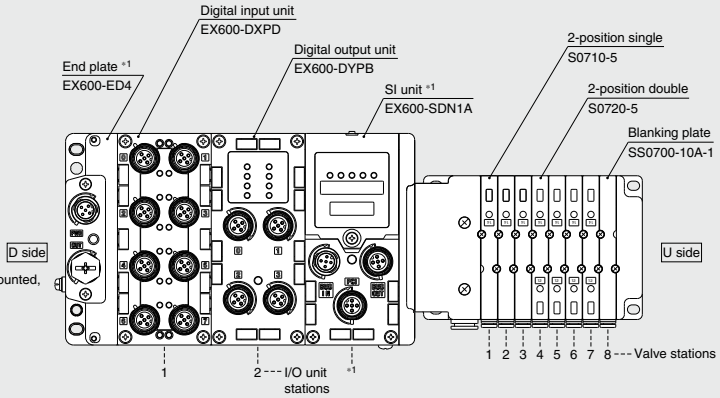

For the I/O unit part number mounted, refer to the **Web Catalog**.

- Digital input unit
- Digital output unit
- Digital I/O unit
- Analog input unit
- Analog output unit
- Analog I/O unit

- SJ
- SY
- SY
- S0700
- S0700

Serial transmission kit

- SS0750-08C4SD6Q4N2 1 set
- * S0710-5 3 sets
- * S0720-5 4 sets
- * SS0700-10A-1 1 set
- * EX600-DXPD 1 set
- * EX600-DYPB 1 set

- Manifold base part number**
- Valve part number (Stations 1 to 3)**
- Valve part number (Stations 4 to 7)**
- Blanking plate number (Station 8)**
- I/O unit part number (Station 1)**
- I/O unit part number (Station 2)**

Enter in order starting from the first station on the D side.
If arrangement becomes complicated, specify on a manifold specification sheet.

Enter in order starting from the first station on the D side.

*1: Do not enter the SI unit part number and the end plate part number together.

The asterisk denotes the symbol for assembly.
Prefix it to the part nos. of the solenoid valve, etc.

How to Order Valves

S07 1 0 [] - 5

Type of actuation

| | | |
|---|-----------------------|---|
| 1 | 2-position single | A 4-position dual 3-port valve (N.C. + N.C.) [Exhaust center] |
| | 2 | |
| | | C 4-position dual 3-port valve (N.C. + N.O.) |

Coil voltage

| | |
|---|--------|
| 5 | 24 VDC |
|---|--------|

Function

| Symbol | Specifications |
|--------|-------------------|
| Nil | Standard |
| R | External pilot *1 |

*1: Not compatible with dual 3-port valves.

Base mounted plug-in

Plug-in Type



S0700 Series Stacking Base

Kit (Serial Transmission) EX600 (For Input/Output Serial Transmission System (Fieldbus System))

Power Supply with M12 Connector

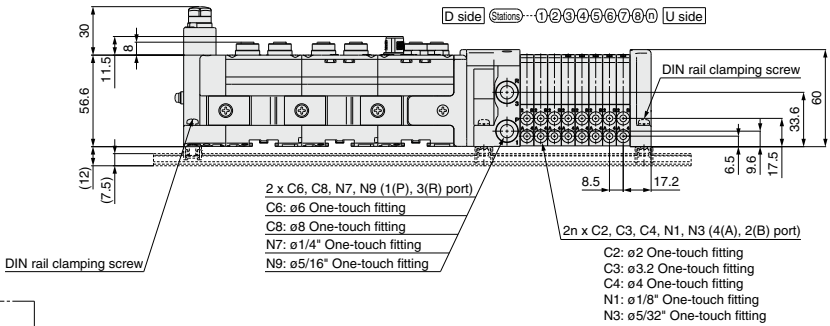
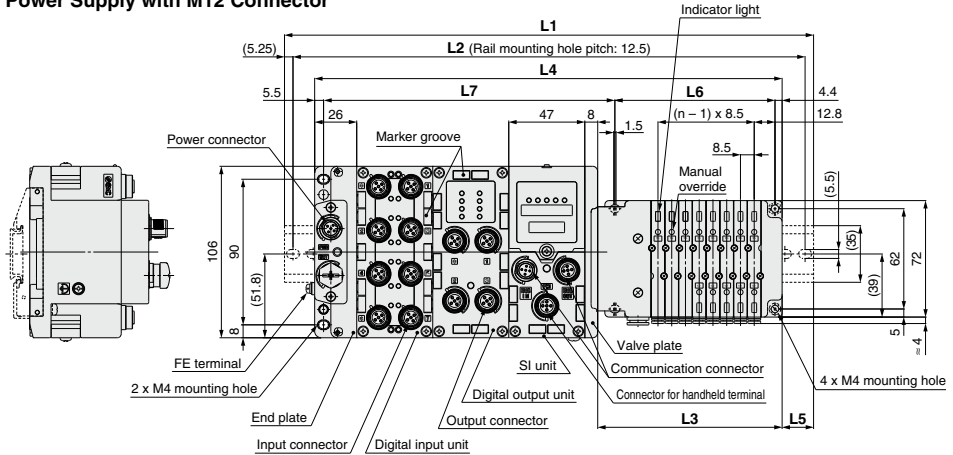

$L2 = L1 - 10.5$
 $L3 = 8.5 \times n1 + 46$
 $L4 = L3 + 81 + 47 \times n2$
 $L5 = (L1 - L4) / 2$
 $L6 = 8.5 \times n1 + 31$
 $L7 = 47 \times n2 + 86.1$

L1: DIN Rail Overall Length

| I/O unit stations (n2) | Valve stations (n1) | | | | | | | | | | | | | | | | | | | | | | | |
|------------------------|---------------------|-------|-------|-------|-------|-------|-------|-------|-------|-------|-------|-------|-------|-------|-------|-------|-------|-------|-------|-------|-------|-------|-------|-------|
| | 1 | 2 | 3 | 4 | 5 | 6 | 7 | 8 | 9 | 10 | 11 | 12 | 13 | 14 | 15 | 16 | 17 | 18 | 19 | 20 | 21 | 22 | 23 | 24 |
| 0 | 173 | 185.5 | 185.5 | 198 | 210.5 | 210.5 | 223 | 235.5 | 235.5 | 248 | 260.5 | 260.5 | 273 | 285.5 | 285.5 | 298 | 310.5 | 310.5 | 323 | 335.5 | 335.5 | 348 | 360.5 | 373 |
| 1 | 223 | 223 | 235.5 | 248 | 248 | 260.5 | 273 | 273 | 285.5 | 298 | 298 | 310.5 | 323 | 323 | 335.5 | 348 | 360.5 | 360.5 | 373 | 385.5 | 385.5 | 398 | 410.5 | 410.5 |
| 2 | 260.5 | 273 | 285.5 | 285.5 | 298 | 310.5 | 310.5 | 323 | 335.5 | 348 | 348 | 360.5 | 373 | 373 | 385.5 | 398 | 398 | 410.5 | 423 | 423 | 435.5 | 448 | 448 | 460.5 |
| 3 | 310.5 | 323 | 335.5 | 335.5 | 348 | 360.5 | 360.5 | 373 | 385.5 | 385.5 | 398 | 410.5 | 410.5 | 423 | 435.5 | 435.5 | 448 | 460.5 | 460.5 | 473 | 485.5 | 485.5 | 498 | 510.5 |
| 4 | 360.5 | 373 | 373 | 385.5 | 398 | 398 | 410.5 | 423 | 423 | 435.5 | 448 | 448 | 460.5 | 473 | 473 | 485.5 | 498 | 498 | 510.5 | 523 | 535.5 | 535.5 | 548 | 560.5 |
| 5 | 410.5 | 410.5 | 423 | 435.5 | 435.5 | 448 | 460.5 | 460.5 | 473 | 485.5 | 485.5 | 498 | 510.5 | 523 | 523 | 535.5 | 548 | 548 | 560.5 | 573 | 573 | 585.5 | 598 | 598 |
| 6 | 448 | 460.5 | 473 | 473 | 485.5 | 498 | 510.5 | 510.5 | 523 | 535.5 | 535.5 | 548 | 560.5 | 560.5 | 573 | 585.5 | 585.5 | 598 | 610.5 | 610.5 | 623 | 635.5 | 635.5 | 648 |
| 7 | 498 | 510.5 | 523 | 523 | 535.5 | 548 | 548 | 560.5 | 573 | 573 | 585.5 | 598 | 598 | 610.5 | 623 | 623 | 635.5 | 648 | 648 | 660.5 | 673 | 673 | 685.5 | 698 |
| 8 | 548 | 560.5 | 560.5 | 573 | 585.5 | 585.5 | 598 | 610.5 | 610.5 | 623 | 635.5 | 635.5 | 648 | 660.5 | 660.5 | 673 | 685.5 | 698 | 698 | 710.5 | 723 | 723 | 735.5 | 748 |
| 9 | 598 | 598 | 610.5 | 623 | 623 | 635.5 | 648 | 648 | 660.5 | 673 | 685.5 | 685.5 | 698 | 710.5 | 710.5 | 723 | 735.5 | 735.5 | 748 | 760.5 | 760.5 | 773 | 785.5 | 785.5 |



Power Supply with 7/8 Inch Connector

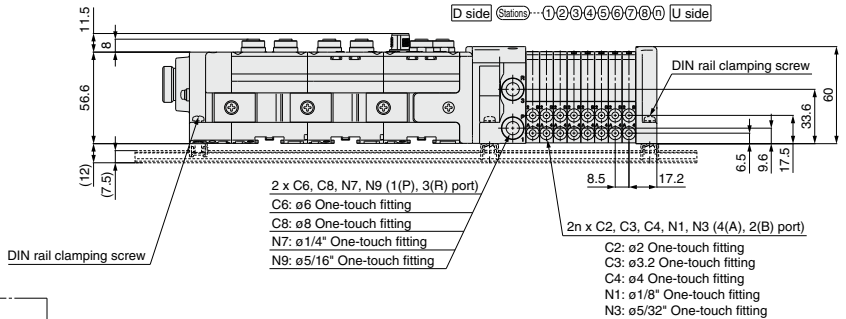
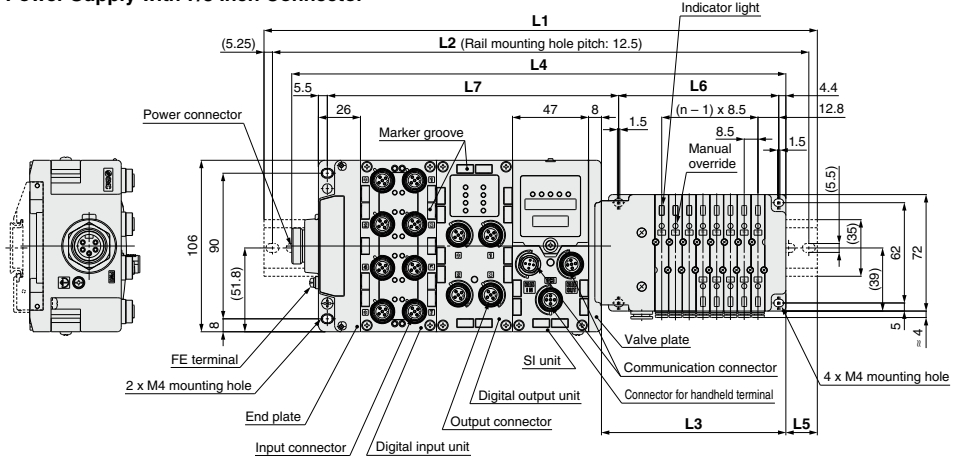

$L2 = L1 - 10.5$
 $L3 = 8.5 \times n1 + 46$
 $L4 = L3 + 97.5 + 47 \times n2$
 $L5 = (L1 - L4) / 2$
 $L6 = 8.5 \times n1 + 31$
 $L7 = 47 \times n2 + 86.1$

L1: DIN Rail Overall Length

| I/O unit stations (n2) | Valve stations (n1) | | | | | | | | | | | | | | | | | | | | | | | |
|------------------------|---------------------|-------|-------|-------|-------|-------|-------|-------|-------|-------|-------|-------|-------|-------|-------|-------|-------|-------|-------|-------|-------|-------|-------|-------|
| | 1 | 2 | 3 | 4 | 5 | 6 | 7 | 8 | 9 | 10 | 11 | 12 | 13 | 14 | 15 | 16 | 17 | 18 | 19 | 20 | 21 | 22 | 23 | 24 |
| 0 | 185.5 | 198 | 210.5 | 210.5 | 223 | 235.5 | 235.5 | 248 | 260.5 | 260.5 | 273 | 285.5 | 285.5 | 298 | 310.5 | 310.5 | 323 | 335.5 | 335.5 | 348 | 360.5 | 360.5 | 373 | 385.5 |
| 1 | 235.5 | 248 | 248 | 260.5 | 273 | 273 | 285.5 | 298 | 298 | 310.5 | 323 | 323 | 335.5 | 348 | 348 | 360.5 | 373 | 385.5 | 385.5 | 398 | 410.5 | 410.5 | 423 | 435.5 |
| 2 | 285.5 | 285.5 | 298 | 310.5 | 310.5 | 323 | 335.5 | 335.5 | 348 | 360.5 | 373 | 373 | 385.5 | 398 | 398 | 410.5 | 423 | 423 | 435.5 | 448 | 448 | 460.5 | 473 | 473 |
| 3 | 323 | 335.5 | 348 | 360.5 | 360.5 | 373 | 385.5 | 385.5 | 398 | 410.5 | 410.5 | 423 | 435.5 | 435.5 | 448 | 460.5 | 460.5 | 473 | 485.5 | 485.5 | 498 | 510.5 | 510.5 | 523 |
| 4 | 373 | 385.5 | 398 | 398 | 410.5 | 423 | 423 | 435.5 | 448 | 448 | 460.5 | 473 | 473 | 485.5 | 498 | 498 | 510.5 | 523 | 523 | 535.5 | 548 | 548 | 560.5 | 560.5 |
| 5 | 423 | 435.5 | 435.5 | 448 | 460.5 | 460.5 | 473 | 485.5 | 485.5 | 498 | 510.5 | 510.5 | 523 | 535.5 | 548 | 548 | 560.5 | 573 | 573 | 585.5 | 598 | 598 | 610.5 | 623 |
| 6 | 473 | 473 | 485.5 | 498 | 498 | 510.5 | 523 | 535.5 | 535.5 | 548 | 560.5 | 560.5 | 573 | 585.5 | 585.5 | 598 | 610.5 | 610.5 | 623 | 635.5 | 635.5 | 648 | 660.5 | 660.5 |
| 7 | 523 | 523 | 535.5 | 548 | 548 | 560.5 | 573 | 573 | 585.5 | 598 | 598 | 610.5 | 623 | 623 | 635.5 | 648 | 648 | 660.5 | 673 | 673 | 685.5 | 698 | 698 | 710.5 |
| 8 | 560.5 | 573 | 585.5 | 585.5 | 598 | 610.5 | 610.5 | 623 | 635.5 | 635.5 | 648 | 660.5 | 660.5 | 673 | 685.5 | 685.5 | 698 | 710.5 | 710.5 | 723 | 723 | 735.5 | 748 | 748 |
| 9 | 610.5 | 623 | 623 | 635.5 | 648 | 648 | 660.5 | 673 | 673 | 685.5 | 698 | 710.5 | 710.5 | 723 | 735.5 | 735.5 | 748 | 760.5 | 760.5 | 773 | 785.5 | 785.5 | 798 | 810.5 |

SJ
SY
SY
S0700
S0700

Plug-in Type

S

S0700 Series Stacking Base

Kit (Serial Transmission) EX500 Gateway Decentralized System 2

How to Order Manifold

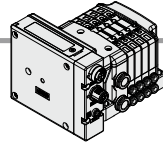

SS0750 - **08** **C4** **C8** **SDA3** **N** - **B**

1 2 3 4 5 6

1 Valve stations

| Stations | Note |
|----------------|--|
| 01 1 station | Double wiring |
| ⋮ | |
| 16 16 stations | |
| 01 1 station | Specified layout*1 (Available up to 32 solenoids) |
| ⋮ | |
| 24 24 stations | |

*1: Specified layout: Indicate the wiring specifications on the manifold specification sheet. (Note that 2-position double, 3-position and 4-position valves cannot be used where single wiring has been specified.) In addition, select the option K.

2 A, B port size

Metric size

| | |
|-----------------|---------------------------|
| C2 | ø2 One-touch fitting |
| C3 | ø3.2 One-touch fitting |
| C4 | ø4 One-touch fitting |
| CM ¹ | Mixed sizes and port plug |

Inch size

| | |
|-----------------|---------------------------|
| N1 | ø1/8" One-touch fitting |
| N3 | ø5/32" One-touch fitting |
| NM ¹ | Mixed sizes and port plug |

*1: Indicate the sizes on the manifold specification sheet.

3 P, R port size

Metric size

| | |
|----|----------------------|
| C6 | ø6 One-touch fitting |
| C8 | ø8 One-touch fitting |

Inch size

| | |
|----|--------------------------|
| N7 | ø1/4" One-touch fitting |
| N9 | ø5/16" One-touch fitting |

*1: If an inch size cylinder port is selected, select inch size piping connections for the P and R ports as well.

4 SI unit (Number of outputs, Max. number of valve stations)

| | |
|------|---|
| SD0 | Without SI unit |
| SDA3 | 32 outputs*1, 2, 1 to 16 stations (24 stations*2) |

*1: When using the SI unit with 32 outputs, use the GW unit compatible with the EX500 Gateway Decentralized System 2 (128 points).

*2: 16 outputs can be set by switching the built-in setting switch.

*3: (): Maximum number of stations for mixed single and double wiring.

*4: For SI unit part number, refer to page 716.

5 SI unit (Output polarity)

| | |
|-----|-------------------|
| Nll | (Without SI unit) |
| N | Negative common |

6 Option

| | |
|--------------------|---|
| Nll | None |
| B ¹ | With back pressure check valve (All stations) |
| D ⁵ | With DIN bracket, DIN rail with standard length |
| D0 ⁵ | With DIN bracket, without DIN rail |
| D□ ^{2, 5} | With DIN bracket, DIN rail for □ stations |
| K ³ | Special wiring specification (Except double wiring) |
| N | With name plate |
| R ⁴ | External pilot |
| S | Built-in silencer |

*1: When a back pressure check valve is used only for specified station, specify the back pressure check valve part number, and specify the station number to which the valve is mounted, on the manifold specification sheet.

*2: □: Specify a longer rail than the length of valve stations.

Example) -D08

In this case, the valves will be mounted on the DIN rail for 8 stations, regardless of the number of manifold stations.

*3: When single wiring and double wiring are mixed, specify wiring type of each station on the manifold specification sheet.

*4: For details, refer to page 718.

*5: When the SD0 (Without SI unit) is specified, -D, -D□ cannot be selected.

*: When multiple symbols are specified, indicate them alphabetically. Example) -BKN

*1: For manifold optional parts, refer to pages 718 to 724.

*: For manifold exploded view, refer to page 714.

How to Order Valves

S07 1 0 □ - 5

• Voltage: 24 VDC

| Symbol | Type of actuation | Specifications |
|--------|---|----------------|
| 1 | 2-position single | |
| 2 | 2-position double | |
| A | 4-position dual 3-port (N.C. + N.C.) [Exhaust center] | |
| B | 4-position dual 3-port (N.O. + N.O.) [Pressure center] | |
| C | 4-position dual 3-port (N.C. + N.O.) | |

*: For symbol, refer to page 652.

• Function

| Symbol | Specifications |
|--------|------------------|
| Nll | Standard |
| R | External pilot*1 |

*1: Not compatible with dual 3-port valves.

The 3(R) port is open to the atmosphere.

(Cannot be used for applying pressure or vacuum)

• Base mounted plug-in

How to Order Manifold Assembly

Example Serial transmission kit

Specify the part numbers for valves and options together beneath the manifold base part number.

SS0750-04C4C8SDA3 ... 1 set - Manifold base part no.
 * S0720-5 2 sets - 2-position double part no.
 * S07A0-5 2 sets - 4-position dual 3-port part no.

Prefix the asterisk to the part numbers of the solenoid valve etc.

Write sequentially from the 1st station on the D side. When part numbers written collectively are complicated, specify on the manifold specification sheet.

Manifold base 2-position double 4-position dual 3-port

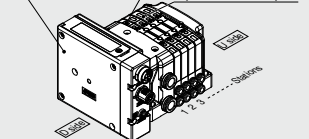

Plug-in Type Stacking Base
EX500 Gateway Decentralized System 2 S0700 Series

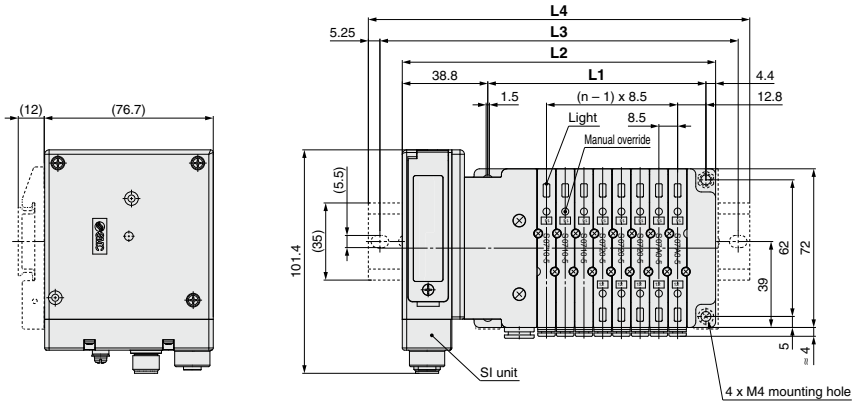

SJ
SY
SY
S0700
S0700

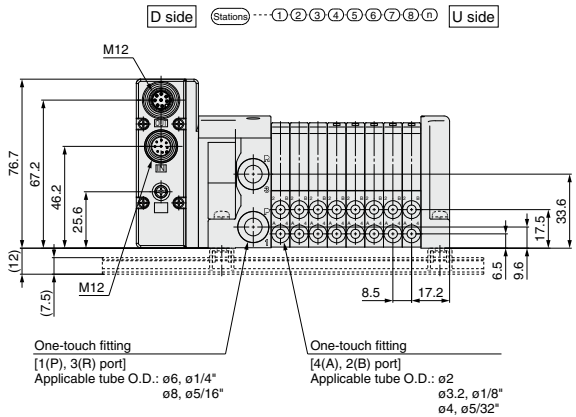

Dimensions

Formula L1 = 8.5n + 31, L2 = 8.5n + 74 n: Station (Maximum 24 stations)

| L \ n | 1 | 2 | 3 | 4 | 5 | 6 | 7 | 8 | 9 | 10 | 11 | 12 | 13 | 14 | 15 | 16 |
|-----------|-------|-------|-------|-------|-------|-------|-------|-------|-------|-------|-------|-------|-------|-------|-------|-------|
| L1 | 39.5 | 48 | 56.5 | 65 | 73.5 | 82 | 90.5 | 99 | 107.5 | 116 | 124.5 | 133 | 141.5 | 150 | 158.5 | 167 |
| L2 | 82.5 | 91 | 99.5 | 108 | 116.5 | 125 | 133.5 | 142 | 150.5 | 159 | 167.5 | 176 | 184.5 | 193 | 201.5 | 210 |
| L3 | 112.5 | 112.5 | 125 | 137.5 | 137.5 | 150 | 162.5 | 162.5 | 175 | 187.5 | 187.5 | 200 | 212.5 | 212.5 | 225 | 237.5 |
| L4 | 123 | 123 | 135.5 | 148 | 148 | 160.5 | 173 | 173 | 185.5 | 198 | 198 | 210.5 | 223 | 223 | 235.5 | 248 |

| L \ n | 17 | 18 | 19 | 20 | 21 | 22 | 23 | 24 |
|-----------|-------|-------|-------|-------|-------|-------|-------|-------|
| L1 | 175.5 | 184 | 192.5 | 201 | 209.5 | 218 | 226.5 | 235 |
| L2 | 218.5 | 227 | 235.5 | 244 | 252.5 | 261 | 269.5 | 278 |
| L3 | 250 | 250 | 262.5 | 275 | 275 | 287.5 | 300 | 300 |
| L4 | 260.5 | 260.5 | 273 | 285.5 | 285.5 | 298 | 310.5 | 310.5 |

Plug-in Type

S

S0700 Series Stacking Base

Kit (Serial Transmission) EX500 Gateway Decentralized System

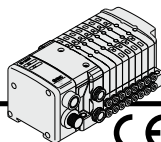

How to Order Manifold

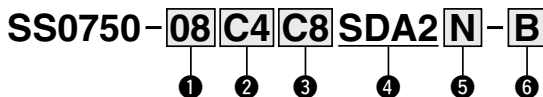

① Valve stations

| Stations | Note |
|----------------|--|
| 01 1 station | Double wiring |
| ⋮ | |
| 08 8 stations | |
| 01 1 station | Specified layout*1 (Available up to 16 solenoids) |
| ⋮ | |
| 16 16 stations | |

*1: Specified layout: Indicate the wiring specifications on the manifold specification sheet. (Note that 2-position double, 3-position and 4-position valves cannot be used where single wiring has been specified.) In addition, select the option K.

② A, B port size

Metric size

| | |
|------|---------------------------|
| C2 | ø2 One-touch fitting |
| C3 | ø3.2 One-touch fitting |
| C4 | ø4 One-touch fitting |
| CM*1 | Mixed sizes and port plug |

Inch size

| | |
|------|---------------------------|
| N1 | ø1/8" One-touch fitting |
| N3 | ø5/32" One-touch fitting |
| NM*1 | Mixed sizes and port plug |

*1: Indicate the sizes on the manifold specification sheet.

③ P, R port size

Metric size

| | |
|----|----------------------|
| C6 | ø6 One-touch fitting |
| C8 | ø8 One-touch fitting |

Inch size

| | |
|----|--------------------------|
| N7 | ø1/4" One-touch fitting |
| N9 | ø5/16" One-touch fitting |

*: If an inch size cylinder port is selected, select inch size piping connections for the P and R ports as well.

④ SI unit (Number of outputs, Max. number of valve stations)

| | |
|------|---|
| SD0 | Without SI unit |
| SDA2 | 16 outputs, 1 to 8 stations (16 stations)*1 |

*1: (): Maximum number of stations for mixed single and double wiring.
*: For SI unit part number, refer to page 716.

⑤ SI unit (Output polarity)

| | |
|-----|-----------------|
| Nii | Positive common |
| N | Negative common |

*: Ensure a match with the common specification of the valve to be used.
*: Select Nil for without SI unit.

⑥ Option

| | |
|--------|---|
| Nil | None |
| B*1 | With back pressure check valve (All stations) |
| D*5 | With DIN bracket, DIN rail with standard length |
| D0*5 | With DIN bracket, without DIN rail |
| D□*2*5 | With DIN bracket, DIN rail for □ stations |
| K*3 | Special wiring specification (Except double wiring) |
| N | With name plate |
| R*4 | External pilot |
| S | Built-in silencer |

*1: When a back pressure check valve is used only for specified station, specify the back pressure check valve part number, and specify the station number to which the valve is mounted, on the manifold specification sheet.

*2: □: Specify a longer rail than the length of valve stations.

Example) -D08

In this case, the valves will be mounted on the DIN rail for 8 stations, regardless of the number of manifold stations.

*3: When single wiring and double wiring are mixed, specify wiring type of each station on the manifold specification sheet.

*4: For details, refer to page 718.

*5: When the SD0 (Without SI unit) is specified, -D, -D□ cannot be selected.

*: When multiple symbols are specified, indicate them alphabetically. Example) -BKN

*: For manifold optional parts, refer to pages 718 to 724.

*: For manifold exploded view, refer to page 714.

How to Order Valves

S07 1 0 □ - 5

• Voltage: 24 VDC

Type of actuation

| Symbol | Specifications |
|--------|---|
| 1 | 2-position single |
| 2 | 2-position double |
| A | 4-position dual 3-port (N.C. + N.C.) [Exhaust center] |
| B | 4-position dual 3-port (N.O. + N.O.) [Pressure center] |
| C | 4-position dual 3-port (N.C. + N.O.) |

*: For symbol, refer to page 652.

Function

| Symbol | Specifications |
|--------|------------------|
| Nil | Standard |
| R | External pilot*1 |

*1: Not compatible with dual 3-port valves.

The 3(R) port is open to the atmosphere.
(Cannot be used for applying pressure or vacuum)

• Base mounted plug-in

How to Order Manifold Assembly

Example Serial transmission kit

Specify the part numbers for valves and options together beneath the manifold base part number.

SS0750-08C4C8SDA2... 1 set - Manifold base part no.
* S0710-5 3 sets - 2-position single part no.
* S0720-5 4 sets - 2-position double part no.
* SS0700-10A-1 1 set - Blanking plate part no.

Prefix the asterisk to the part
Write sequentially from the 1st station on the D side. When part numbers written collectively are complicated, specify on the manifold specification sheet.

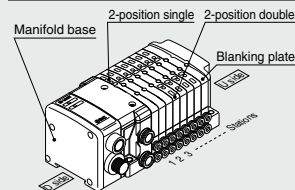

Plug-in Type Stacking Base
EX500 Gateway Decentralized System S0700 Series

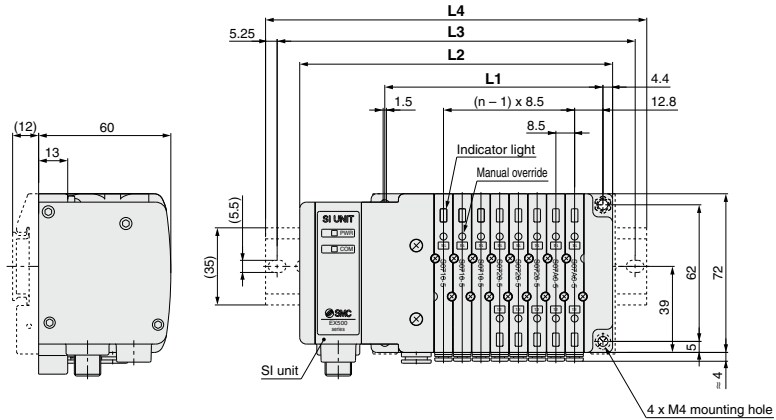

D side Stations ① ② ③ ④ ⑤ ⑥ ⑦ ⑧ ⑨ ⑩ ⑪ ⑫ ⑬ ⑭ ⑮ ⑯ U side

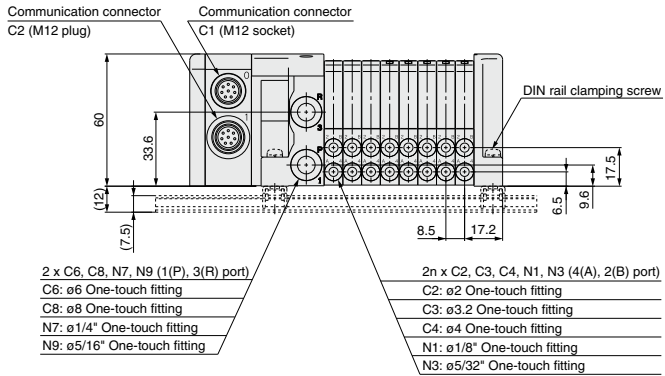

Dimensions

Formula L1 = 8.5n + 31, L2 = 8.5n + 74 n: Station (Maximum 16 stations)

| L \ n | 2 | 3 | 4 | 5 | 6 | 7 | 8 | 9 | 10 | 11 | 12 | 13 | 14 | 15 | 16 |
|-------|-------|-------|-------|-------|-------|-------|-------|-------|-------|-------|-------|-------|-------|-------|-------|
| L1 | 48 | 56.5 | 65 | 73.5 | 82 | 90.5 | 99 | 107.5 | 116 | 124.5 | 133 | 141.5 | 150 | 158.5 | 167 |
| L2 | 91 | 99.5 | 108 | 116.5 | 125 | 133.5 | 142 | 150.5 | 159 | 167.5 | 176 | 184.5 | 193 | 201.5 | 210 |
| L3 | 112.5 | 125 | 137.5 | 150 | 162.5 | 175 | 187.5 | 198 | 210.5 | 222 | 233.5 | 245 | 256.5 | 267.5 | 278.5 |
| L4 | 123 | 135.5 | 148 | 160.5 | 173 | 185.5 | 198 | 210.5 | 223 | 235.5 | 248 | 260.5 | 272.5 | 284.5 | 296.5 |

Plug-in Type Stacking Base

D-sub Connector

F Kit



SJ

SY

SY

S0700

S0700

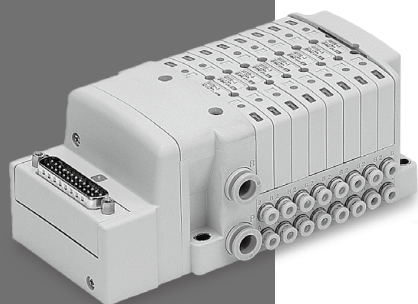

MIL Standard

- 25 pins
- Cable length: 1.5 m, 3 m, 5 m

Connector mounting direction: top or side selectable

➤ Page 690

Plug-in Type

F S0700 Series Stacking Base Kit (D-sub Connector)

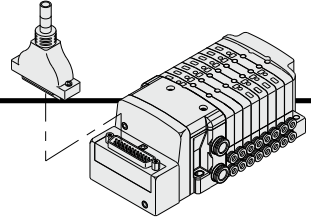

- The D-sub connector reduces installation labor for electrical connections.
- Using the D-sub connector (25P), conforming to MIL standard permits the use of connectors put on the market and gives a wide interchangeability.
- Top or side receptacle position can be selected in accordance with the available mounting space.

Electrical Wiring Specifications

D-sub connector

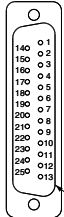

As the standard electrical wiring specifications, double wiring (connected to SOL. A and SOL. B) is adopted for the internal wiring of each station for 12 stations or less, regardless of valve and option types. Mixed single and double wiring is available as an option. For details, refer to Special Wiring Specifications (Option) below.

D-sub connector assembly⁰¹⁵ wire color (AXT100-DS25-030⁰³⁰ 050)

| Terminal no. | Polarity | Lead wire color | Dot marking |
|--------------|----------|-----------------|--------------|
| Station 1 | SOL.A 1 | (-) (+) | Black None |
| | SOL.B 14 | (-) (+) | Yellow Black |
| Station 2 | SOL.A 2 | (-) (+) | Brown None |
| | SOL.B 15 | (-) (+) | Pink Black |
| Station 3 | SOL.A 3 | (-) (+) | Red None |
| | SOL.B 16 | (-) (+) | Blue White |
| Station 4 | SOL.A 4 | (-) (+) | Orange None |
| | SOL.B 17 | (-) (+) | Purple None |
| Station 5 | SOL.A 5 | (-) (+) | Yellow None |
| | SOL.B 18 | (-) (+) | Gray None |
| Station 6 | SOL.A 6 | (-) (+) | Pink None |
| | SOL.B 19 | (-) (+) | Orange Black |
| Station 7 | SOL.A 7 | (-) (+) | Blue None |
| | SOL.B 20 | (-) (+) | Red White |
| Station 8 | SOL.A 8 | (-) (+) | Purple White |
| | SOL.B 21 | (-) (+) | Brown White |
| Station 9 | SOL.A 9 | (-) (+) | Gray Black |
| | SOL.B 22 | (-) (+) | Pink Red |
| Station 10 | SOL.A 10 | (-) (+) | White Black |
| | SOL.B 23 | (-) (+) | Gray Red |
| Station 11 | SOL.A 11 | (-) (+) | White Red |
| | SOL.B 24 | (-) (+) | Black White |
| Station 12 | SOL.A 12 | (-) (+) | Yellow Red |
| | SOL.B 25 | (-) (+) | White None |
| COM. | 13 | (+) (-) | Orange Red |

Positive COM Negative¹¹ COM

*1: Mounting valve has no polarity. It can also be used as a negative common.

Special Wiring Specifications (Option) [-K]

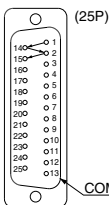

Mixed single and double wiring are available as an option. The maximum number of manifold stations is determined by the number of solenoids. Count one point for a single solenoid type and two points for a double solenoid type. The total number of solenoids (points) must not exceed 24.

1. How to Order valves

Indicate an option symbol, -K, for the manifold part number and be sure to specify the mounting position and number of stations of the single and double wiring on the manifold specification sheet.

2. Wiring specifications

Connector terminal numbers are connected from solenoid station 1 on the A side in the order indicated by the arrows without skipping any terminal numbers.

Cable Assembly

015
AXT100-DS25-030
050

(The D-sub connector cable assemblies can be ordered with manifolds.)
(Refer to How to Order Manifold.)

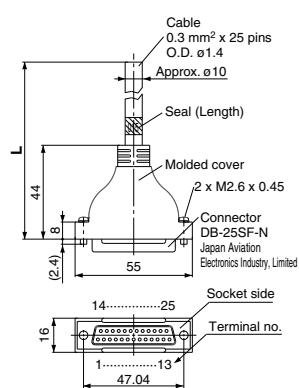

D-sub connector cable assembly Wire Color by Terminal No.

| Terminal no. | Lead wire color | Dot marking |
|--------------|-----------------|-------------|
| 1 | Black | None |
| 2 | Brown | None |
| 3 | Red | None |
| 4 | Orange | None |
| 5 | Yellow | None |
| 6 | Pink | None |
| 7 | Blue | None |
| 8 | Purple | White |
| 9 | Gray | Black |
| 10 | White | Black |
| 11 | White | Red |
| 12 | Yellow | Red |
| 13 | Orange | Red |
| 14 | Yellow | Black |
| 15 | Pink | Black |
| 16 | Blue | White |
| 17 | Purple | None |
| 18 | Gray | None |
| 19 | Orange | Black |
| 20 | Red | White |
| 21 | Brown | White |
| 22 | Pink | Red |
| 23 | Gray | Red |
| 24 | Black | White |
| 25 | White | None |

D-sub Connector Cable Assembly (Option)

| Cable length (L) | Assembly part no. | Note |
|------------------|-------------------|--------------------------------------|
| 1.5 m | AXT100-DS25-015 | Cable 0.3 mm ² x 25 cores |
| 3 m | AXT100-DS25-030 | |
| 5 m | AXT100-DS25-050 | |

*1: For other commercial connectors, use a 25-pin type with female connector conforming to MIL-C-24308.

*2: Cannot be used for movable wiring.

Electrical Characteristics

| Item | Property |
|--------------------------------------|------------|
| Conductor resistance Ω/km, 20°C | 65 or less |
| Voltage limit V, 1 min, AC | 1000 |
| Insulation resistance MΩ/km, 20°C | 5 or more |

*3: The minimum bending inner radius of D-sub connector cable is 20 mm.

Connector manufacturers' example

- Fujitsu Limited
- Japan Aviation Electronics Industry, Limited
- J.S.T. Mfg. Co., Ltd.
- HIROSE ELECTRIC CO., LTD.



How to Order Manifold

SS0750-08 C4 C8 FD1-B

Stations

| Symbol | Stations |
|--------|-------------|
| 01 | 1 station |
| ⋮ | ⋮ |
| 24*1 | 24 stations |

*1: The maximum number of stations will be different depending on the wiring specifications.

Cylinder port size

| Symbol | Port size | |
|--------|----------------------------------|--------|
| C2 | With ø2 One-touch fitting | Metric |
| C3 | With ø3.2 One-touch fitting | |
| C4 | With ø4 One-touch fitting | |
| CM | Mixed sizes and with port plug*1 | |
| N1 | With ø1/8" One-touch fitting | Inch |
| N3 | With ø5/32" One-touch fitting | |
| NM | Mixed sizes and with port plug*1 | |

*1: Indicate the sizes on the manifold specification sheet in the case of CM and NM.

P, R port size

| Symbol | Port size | |
|--------|-------------------------------|--------|
| C6 | With ø6 One-touch fitting | Metric |
| C8 | With ø8 One-touch fitting | |
| N7 | With ø1/4" One-touch fitting | Inch |
| N9 | With ø5/16" One-touch fitting | |

*: If an inch size cylinder port is selected, select inch size piping connections for the P and R ports as well.

Option

| Symbol | Specifications |
|--------|--|
| Nil | None |
| B*1 | With back pressure check valve (All sta.) |
| D | With DIN rail (Rail length: Standard) |
| D0 | Without DIN rail (With bracket) |
| D□*2 | With DIN rail Designated length (□: Station) |
| K*3 | Special wiring specifications (Except double wiring) |
| N | With name plate |
| R*4 | External pilot |
| S | Built-in silencer |

*1: When installing a back pressure check valve on the required station, enter the part number and specify the station position on the manifold specification sheet.

*2: The available number of stations is larger than the number of manifold stations.

*3: Indicate the wiring specifications for mixed single and double wirings.

*4: For details, refer to page 718.

*: When two or more options are specified, indicate them alphabetically. Example) -BKN

*: For manifold optional parts, refer to pages 718 to 724.

*: For manifold exploded view, refer to page 714.

Kit type/Cable length

| Kit type | Symbol | Specifications | Standard station | Max. number of stations for special wiring specifications | Max. number of solenoids |
|----------|--------|---|------------------|---|--------------------------|
| F kit | FD0 | D-sub connector (25P), without cable | 1 to 12 stations | 24 stations | 24 |
| | FD1 | D-sub connector (25P), with 1.5 m cable | | | |
| | FD2 | D-sub connector (25P), with 3.0 m cable | | | |
| | FD3 | D-sub connector (25P), with 5.0 m cable | | | |

*: The maximum number of stations is determined by the total number of solenoids. For mixed single and double wirings, enter -K to the order code options.

| Type of actuation | Single | Double, Dual 3-port |
|---------------------|--------|---------------------|
| Number of solenoids | 1 | 2 |

How to Order Valves

S07 1 0 - 5

Type of actuation

| Symbol | Specifications |
|--------|--|
| 1 | 2-position single |
| 2 | 2-position double |
| A | 4-position dual 3-port (N.C. + N.C.) [Exhaust center] |
| B | 4-position dual 3-port (N.O. + N.O.) [Pressure center] |
| C | 4-position dual 3-port (N.C. + N.O.) |

*: For symbol, refer to page 652.

Voltage

| Symbol | Specifications |
|--------|----------------|
| 5 | 24 VDC |
| 6 | 12 VDC |

Function

| Symbol | Specifications |
|--------|------------------|
| Nil | Standard |
| R | External pilot*1 |

*1: Not compatible with dual 3-port valves. The 3(R) port is open to the atmosphere. (Cannot be used for applying pressure or vacuum)

Base mounted plug-in

How to Order Manifold Assembly

Example D-sub connector kit

Specify the part numbers for valves and options together beneath the manifold base part number.

SS0750-08C4C8FD1-... 1 set - Manifold base part no.
 * S0710-5 3 sets - Valve part no. (Stations 1 to 3)
 * S0720-5 2 sets - Valve part no. (Stations 4 to 5)
 * S07A0-5 2 sets - Valve part no. (Stations 6 to 7)
 * SS0700-10A-1 1 set - Blanking plate part no. (Station 8)

Prefix the asterisk to the part numbers of the solenoid valve etc. Write sequentially from the 1st station on the D side. When part numbers written collectively are complicated, specify on the manifold specification sheet.

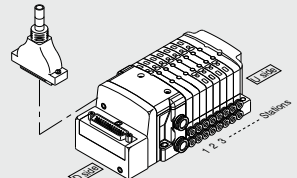

F

S0700 Series Kit (D-sub Connector)

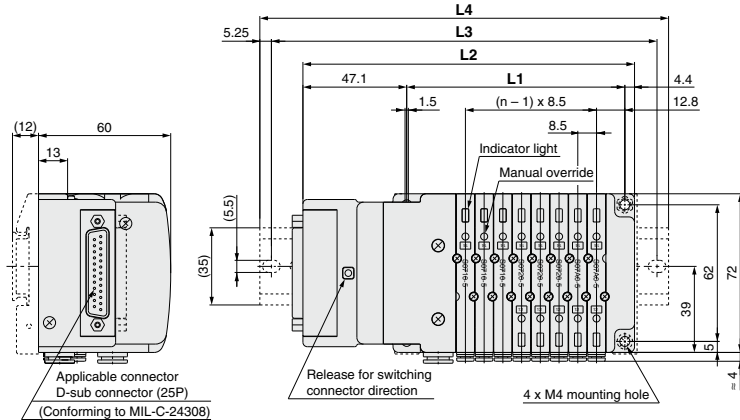

D side Stations ① ② ③ ④ ⑤ ⑥ ⑦ ⑧ ⑨ U side

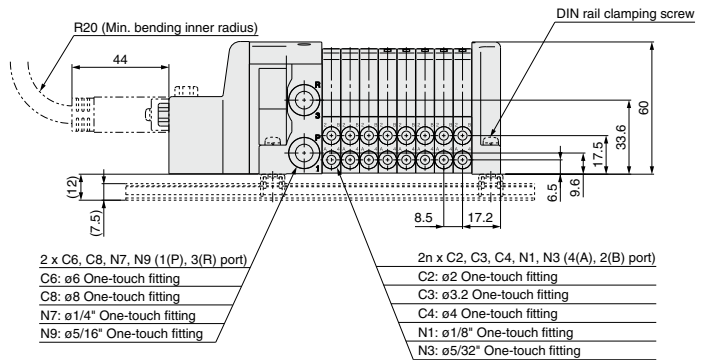

Dimensions

Formula L1 = 8.5n + 31, L2 = 8.5n + 82.5 n: Station (Maximum 24 stations)

| L \ n | 2 | 3 | 4 | 5 | 6 | 7 | 8 | 9 | 10 | 11 | 12 | 13 | 14 | 15 | 16 | 17 | 18 | 19 | 20 | 21 | 22 | 23 | 24 |
|-------|-------|-------|-------|-------|-------|-------|-------|-------|-------|-------|-------|-------|-------|-------|-------|-------|-------|-------|-------|-------|-------|-------|-------|
| L1 | 48 | 56.5 | 65 | 73.5 | 82 | 90.5 | 99 | 107.5 | 116 | 124.5 | 133 | 141.5 | 150 | 158.5 | 167 | 175.5 | 184 | 192.5 | 201 | 209.5 | 218 | 226.5 | 235 |
| L2 | 99.5 | 108 | 116.5 | 125 | 133.5 | 142 | 150.5 | 159 | 167.5 | 176 | 184.5 | 193 | 201.5 | 210 | 218.5 | 227 | 235.5 | 244 | 252.5 | 261 | 269.5 | 278 | 286.5 |
| L3 | 125 | 137.5 | 137.5 | 150 | 162.5 | 162.5 | 175 | 187.5 | 187.5 | 200 | 212.5 | 212.5 | 225 | 237.5 | 250 | 262.5 | 275 | 287.5 | 300 | 300 | 312.5 | 312.5 | 312.5 |
| L4 | 135.5 | 148 | 148 | 160.5 | 173 | 173 | 185.5 | 198 | 198 | 210.5 | 223 | 223 | 235.5 | 248 | 260.5 | 260.5 | 273 | 285.5 | 285.5 | 298 | 310.5 | 310.5 | 323 |

Plug-in Type Stacking Base

Flat Ribbon Cable

P Kit



SJ

SY

SY

S0700

S0700

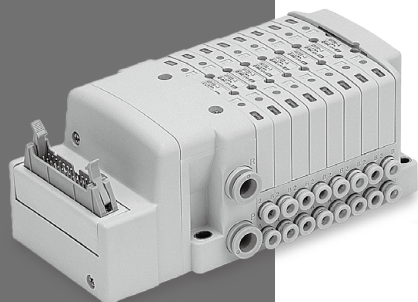

MIL Standard

■ 26 pins, 20 pins

■ Cable length: 1.5 m, 3 m, 5 m

Connector mounting direction: top or side selectable

➤ Page 694

Plug-in Type

P

S0700 Series Stacking Base Kit (Flat Ribbon Cable)

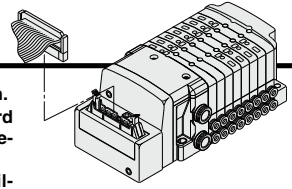

- Flat ribbon cable connector reduces installation labor for electrical connection.
- Using the connector for flat ribbon cable (26P, 20P) conforming to MIL standard permits the use of connectors put on the market and gives a wide interchangeability.
- Top or side receptacle position can be selected in accordance with the available mounting space.

Electrical Wiring Specifications

Flat ribbon cable connector

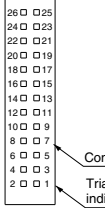

Double wiring (connected to SOL. A and SOL. B) is adopted for the internal wiring of each station, regardless of valve and option types.
Mixed single and double wiring is available as an option. For details, refer to Special Wiring Specifications (Option) below.

Connector terminal no.
Triangle mark indicator position

<26P>

Terminal Polarity no.

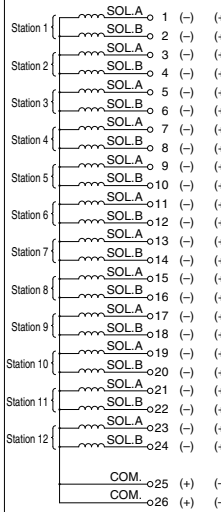

<20P>

Terminal Polarity no.

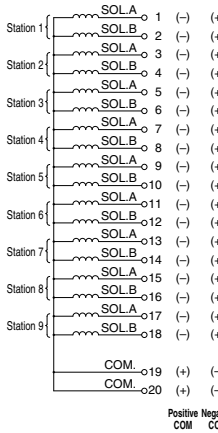

Positive Negative^{*1}
COM COM

*1: Mounting valve has no polarity. It can also be used as a negative common.

Cable Assembly

AXT100-FC²⁰₂₆¹-²₃

(Type 26P flat ribbon cable connector assemblies can be ordered) with manifolds. Refer to How to Order Manifold.

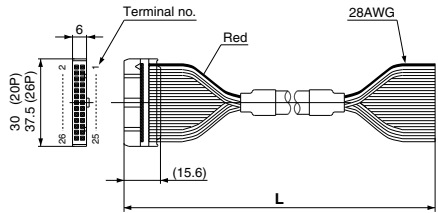

Flat Ribbon Cable Connector Assembly (Option)

| Cable length (L) | Assembly part no. | |
|------------------|-------------------|---------------|
| | 26P | 20P |
| 1.5 m | AXT100-FC26-1 | AXT100-FC20-1 |
| 3 m | AXT100-FC26-2 | AXT100-FC20-2 |
| 5 m | AXT100-FC26-3 | AXT100-FC20-3 |

*: For other commercial connectors, use a 20- or 26-pin type with strain relief conforming to MIL-C-83503.
*: Cannot be used for movable wiring.

Connector manufacturers' example

- HIROSE ELECTRIC CO., LTD.
- 3M Japan Limited
- Fujitsu Limited
- Japan Aviation Electronics Industry, Limited
- J.S.T. Mfg. Co., Ltd.
- Oki Electric Cable Co., Ltd.

Special Wiring Specifications (Option) [-K]

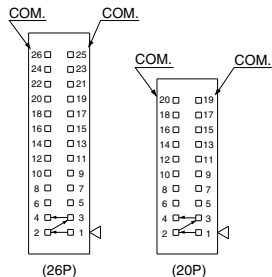

Mixed single and double wiring are available as an option. The maximum number of manifold stations is determined by the number of solenoids. Count one point for a single solenoid type and two points for a double solenoid type. The total number of solenoids (points) must not exceed 24 for 26P, 18 for 20P.

1. How to Order valves
Indicate an option symbol, -K, for the manifold part number and be sure to specify the mounting position and number of stations of the single and double wiring on the manifold specification sheet.

2. Wiring specifications
Connector terminal numbers are connected from solenoid station 1 on the A side in the order indicated by the arrows without skipping any terminal numbers.



How to Order Manifold

SS0750-08 C4 C8 PD1-B

Stations ↓

| Symbol | Stations |
|--------|-------------|
| 01 | 1 station |
| ⋮ | ⋮ |
| 24 | 24 stations |

*: The maximum number of stations will be different depending on the wiring specifications.

Cylinder port size ↓

| Symbol | Port size | |
|--------|-------------------------------|--------|
| C2 | With ø2 One-touch fitting | Metric |
| C3 | With ø3.2 One-touch fitting | |
| C4 | With ø4 One-touch fitting | |
| CM | Mixed sizes and with plug*1 | Inch |
| N1 | With ø1/8" One-touch fitting | |
| N3 | With ø5/32" One-touch fitting | |
| NM | Mixed sizes and with plug*1 | |

*1: Indicate the sizes on the manifold specification sheet in the case of CM and NM.

P, R port size ↓

| Symbol | Port size | |
|--------|-------------------------------|--------|
| C6 | With ø6 One-touch fitting | Metric |
| C8 | With ø8 One-touch fitting | |
| N7 | With ø1/4" One-touch fitting | Inch |
| N9 | With ø5/16" One-touch fitting | |

*: If an inch size cylinder port is selected, select inch size piping connections for the P and R ports as well.

Option

| Symbol | Specifications |
|--------|--|
| Nil | None |
| B*1 | With back pressure check valve (All sta.) |
| D | With DIN rail (Rail length: Standard) |
| D0 | Without DIN rail (With bracket) |
| D□*2 | With DIN rail Designated length (□: Station) |
| K*3 | Special wiring specifications (Except double wiring) |
| N | With name plate |
| R*4 | External pilot |
| S | Built-in silencer |

- *1: When installing a back pressure check valve on the required station, enter the part number and specify the station position on the manifold specification sheet.
- *2: The available number of stations is larger than the number of manifold stations.
- *3: Indicate the wiring specifications for mixed single and double wirings.
- *4: For details, refer to page 718.
- *: When two or more options are specified, indicate them alphabetically. Example) -BKN
- *: For manifold optional parts, refer to pages 718 to 724.
- *: For manifold exploded view, refer to page 714.

Kit type/Cable length ↓

| Kit type | Symbol | Specifications | Standard station | Max. number of stations for special wiring specifications | Max. number of solenoids |
|----------|--------|---|------------------|---|--------------------------|
| P kit | PD0 | Flat ribbon cable (26P), without cable | 1 to 12 stations | 24 stations | 24 |
| | PD1 | Flat ribbon cable (26P), with 1.5 m cable | | | |
| | PD2 | Flat ribbon cable (26P), with 3.0 m cable | | | |
| | PD3 | Flat ribbon cable (26P), with 5.0 m cable | 1 to 9 stations | 18 stations | 18 |
| | PDC | Flat ribbon cable (20P), without cable | | | |

*: The maximum number of stations is determined by the total number of solenoids. For mixed single and double wirings, enter -K to the order code options.

| Type of actuation | Single | Double, Dual 3-port |
|---------------------|--------|---------------------|
| Number of solenoids | 1 | 2 |

How to Order Valves

S07 1 0 □ - 5

Type of actuation ↓

| Symbol | Specifications |
|--------|--|
| 1 | 2-position single |
| 2 | 2-position double |
| A | 4-position dual 3-port (N.C. + N.C.) [Exhaust center] |
| B | 4-position dual 3-port (N.O. + N.O.) [Pressure center] |
| C | 4-position dual 3-port (N.C. + N.O.) |

*: For symbol, refer to page 652.

Voltage ↓

| Symbol | Specifications |
|--------|----------------|
| 5 | 24 VDC |
| 6 | 12 VDC |

Function ↓

| Symbol | Specifications |
|--------|------------------|
| Nil | Standard |
| R | External pilot*1 |

*1: Not compatible with dual 3-port valves. The 3(R) port is open to the atmosphere. (Cannot be used for applying pressure or vacuum)

Base mounted plug-in ↓

How to Order Manifold Assembly

Example Flat ribbon cable kit

Specify the part numbers for valves and options together beneath the manifold base part number.

- SS0750-08C4C8PD1... 1 set - Manifold base part no.
- * S0710-5 2 sets - Valve part no. (Stations 1 to 3)
- * S0720-5 4 sets - Valve part no. (Stations 4 to 5)
- * S07A0-5 1 set - Valve part no. (Stations 6 to 7)
- * SS0700-10A-1 1 set - Blanking plate part no. (Station 8)

Prefix the asterisk to the part numbers of the solenoid valve etc. Write sequentially from the 1st station on the D side. When part numbers written collectively are complicated, specify on the manifold specification sheet.

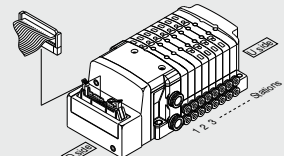

P S0700 Series Kit (Flat Ribbon Cable)

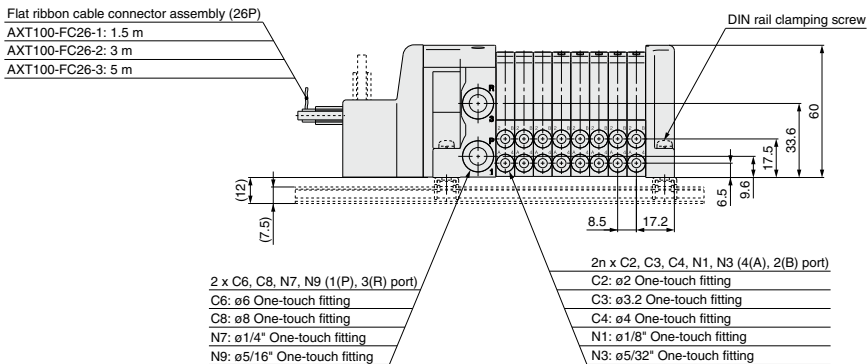
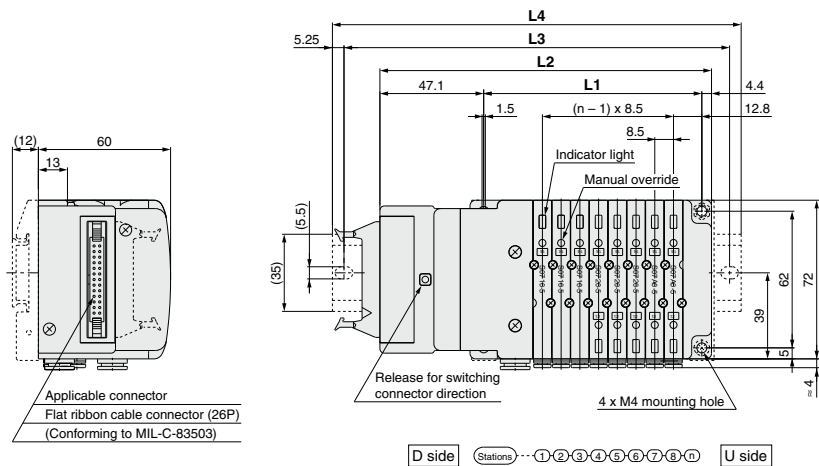

Dimensions

Formula L1 = 8.5n + 31, L2 = 8.5n + 82.5 n: Station (Maximum 24 stations)

| L \ n | 2 | 3 | 4 | 5 | 6 | 7 | 8 | 9 | 10 | 11 | 12 | 13 | 14 | 15 | 16 | 17 | 18 | 19 | 20 | 21 | 22 | 23 | 24 |
|-------|-------|-------|-------|-------|-------|-------|-------|-------|-------|-------|-------|-------|-------|-------|-------|-------|-------|-------|-------|-------|-------|-------|-------|
| L1 | 48 | 56.5 | 65 | 73.5 | 82 | 90.5 | 99 | 107.5 | 116 | 124.5 | 133 | 141.5 | 150 | 158.5 | 167 | 175.5 | 184 | 192.5 | 201 | 209.5 | 218 | 226.5 | 235 |
| L2 | 99.5 | 108 | 116.5 | 125 | 133.5 | 142 | 150.5 | 159 | 167.5 | 176 | 184.5 | 193 | 201.5 | 210 | 218.5 | 227 | 235.5 | 244 | 252.5 | 261 | 269.5 | 278 | 286.5 |
| L3 | 125 | 137.5 | 150 | 162.5 | 175 | 187.5 | 200 | 212.5 | 225 | 237.5 | 250 | 262.5 | 275 | 287.5 | 300 | 312.5 | 325 | 337.5 | 350 | 362.5 | 375 | 387.5 | 400 |
| L4 | 135.5 | 148 | 160.5 | 173 | 185.5 | 198 | 210.5 | 223 | 235.5 | 248 | 260.5 | 273 | 285.5 | 298 | 310.5 | 323 | 335.5 | 348 | 360.5 | 373 | 385.5 | 398 | 410.5 |

Plug-in Type Stacking Base

Terminal Block Box

T Kit



SJ

SY

SY

S0700

S0700

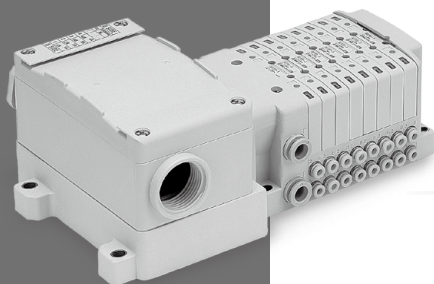

With Terminal Block Box

→ Page 702

Plug-in Type

T

S0700 Series Stacking Base Kit (Terminal Block Box)

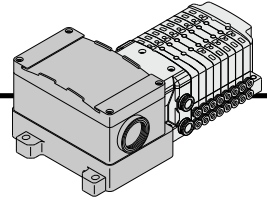

- This kit has a small terminal box inside a junction box. The electrical entry port (G3/4) permits connection of conduit fittings.

Terminal Block Connection

Step 1. How to remove terminal block cover

Loosen the 4 mounting screws (M4) and open the terminal block cover.

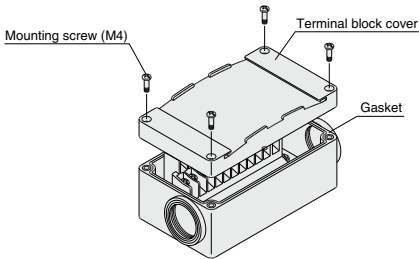

Step 2. The diagram below shows the terminal block wiring schematic. All stations are provided with double solenoid wiring.

Connect each wire to the power supply side, according to the markings provided inside the terminal block.

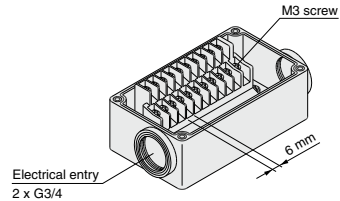

Step 3. How to replace terminal block cover

Securely tighten the screws with the torque shown in the table below, after confirming that the gasket is installed correctly.

| Proper tightening torque [N·m] |
|--------------------------------|
| 0.7 to 1.2 |

- Applicable crimped terminal: 1.25-3S, 1.25Y-3, 1.25Y-3N, 1.25Y-3.5
- Drip proof plug assembly (for G3/4): AXT100-B06A

Electrical Wiring Specifications

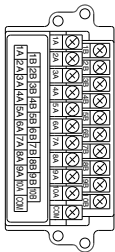

Double wiring (connected to SOL A and SOL B) is adopted for the internal wiring of each station, regardless of valve and option types. Mixed single and double wiring is available as an option.

*1: Mounting valve has no polarity. It can also be used as a negative common.

Standard wiring

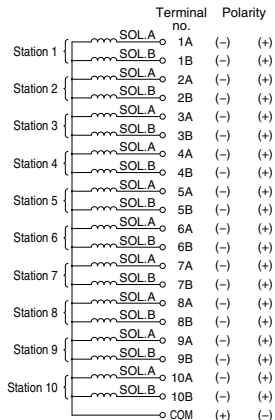

Positive COM⁺¹ Negative COM

Special Wiring Specifications (Option) [-K]

Mixed single and double wiring are available as an option. The maximum number of manifold stations is determined by the number of solenoids. Count one point for a single solenoid type and two points for a double solenoid type. The total number of solenoids (points) must not exceed 20.

1. How to Order valves

Indicate an option symbol, -K, for the manifold part number and be sure to specify the mounting position and number of stations of the single and double wiring on the manifold specification sheet.

2. Wiring specifications

Connector terminal numbers are connected from solenoid station 1 on the A side in the order indicated by the arrows without skipping any terminal numbers.

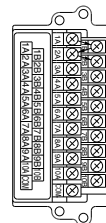



How to Order Manifold

SS0750-08 C4 C8 TD0-B

Stations

| Symbol | Stations |
|------------------------|-------------|
| 01 | 1 station |
| : | : |
| 20^{*1} | 20 stations |

*1: The maximum number of stations will be different depending on the wiring specifications.

Cylinder port size

| Symbol | Port size | |
|-----------|--|--------|
| C2 | With ø2 One-touch fitting | Metric |
| C3 | With ø3.2 One-touch fitting | |
| C4 | With ø4 One-touch fitting | |
| CM | Mixed sizes and with port plug ^{*1} | Inch |
| N1 | With ø1/8" One-touch fitting | |
| N3 | With ø5/32" One-touch fitting | |
| NM | Mixed sizes and with port plug ^{*1} | |

*1: Specify "Mixed sizes and with port plug" on the manifold specification sheet.

P, R port size

| Symbol | Port size | |
|-----------|-------------------------------|--------|
| C6 | With ø6 One-touch fitting | Metric |
| C8 | With ø8 One-touch fitting | |
| N7 | With ø1/4" One-touch fitting | Inch |
| N9 | With ø5/16" One-touch fitting | |

*: If an inch size cylinder port is selected, select inch size piping connections for the P and R ports as well.

Option

| Symbol | Specifications |
|------------------------|--|
| Nil | None |
| B^{*1} | With back pressure check valve (All stations) |
| D | With DIN rail (Rail length: Standard) |
| D0 | Without DIN rail (With bracket) |
| D□^{*2} | With DIN rail Designated length (□: Station) |
| K^{*3} | Special wiring specifications (Except double wiring) |
| N | With name plate |
| R^{*4} | External pilot |
| S | Built-in silencer |

*1: When installing a back pressure check valve on the required station, enter the part number and specify the station position on the manifold specification sheet.

*2: The available number of stations is larger than the number of manifold stations.

*3: Indicate the wiring specifications for mixed single and double wirings.

*4: For details, refer to page 718.

*: When two or more options are specified, indicate them alphabetically. Example) -BKN

*: For manifold optional parts, refer to pages 718 to 724.

*: For manifold exploded view, refer to page 714.

Kit type

| Kit type | Symbol | Specifications | Standard station | Max. number of stations for special wiring specifications | Max. number of solenoids |
|----------|------------|----------------|------------------|---|--------------------------|
| T kit | TD0 | Terminal block | 1 to 10 stations | 20 stations | 20 |

*: The maximum number of stations is determined by the total number of solenoids. For mixed single and double wirings, enter -K to the order code options.

| Type of actuation | Single | Double, Dual 3-port |
|---------------------|--------|---------------------|
| Number of solenoids | 1 | 2 |

How to Order Valves

S07 1 0 □ - 5

Type of actuation

| Symbol | Specifications |
|----------|--|
| 1 | 2-position single |
| 2 | 2-position double |
| A | 4-position dual 3-port (N.C. + N.C.) [Exhaust center] |
| B | 4-position dual 3-port (N.O. + N.O.) [Pressure center] |
| C | 4-position dual 3-port (N.C. + N.O.) |

*: For symbol, refer to page 652.

Voltage

| Symbol | Specifications |
|----------|----------------|
| 5 | 24 VDC |
| 6 | 12 VDC |

Function

| Symbol | Specifications |
|------------|------------------------------|
| Nil | Standard |
| R | External pilot ^{*1} |

*1: Not compatible with dual 3-port valves. The 3(R) port is open to the atmosphere. (Cannot be used for applying pressure or vacuum)

Base mounted plug-in

How to Order Manifold Assembly

Example Terminal block box kit

Specify the part numbers for valves and options together beneath the manifold base part number.

SS0750-08C4C8TD0-1 1 set - Manifold base part no.
 * **S0710-5** 3 sets - Valve part no. (Stations 1 to 3)
 * **S0720-5** 2 sets - Valve part no. (Stations 4 to 5)
 * **S07A0-5** 2 sets - Valve part no. (Stations 6 to 7)
 * **SS0700-10A-1** 1 set - Blanking plate part no. (Station 8)

Prefix the asterisk to the part numbers of the solenoid valve etc. Write sequentially from the 1st station on the D side. When part numbers written collectively are complicated, specify on the manifold specification sheet.

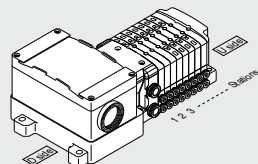



S0700 Series Kit (Terminal Block Box)

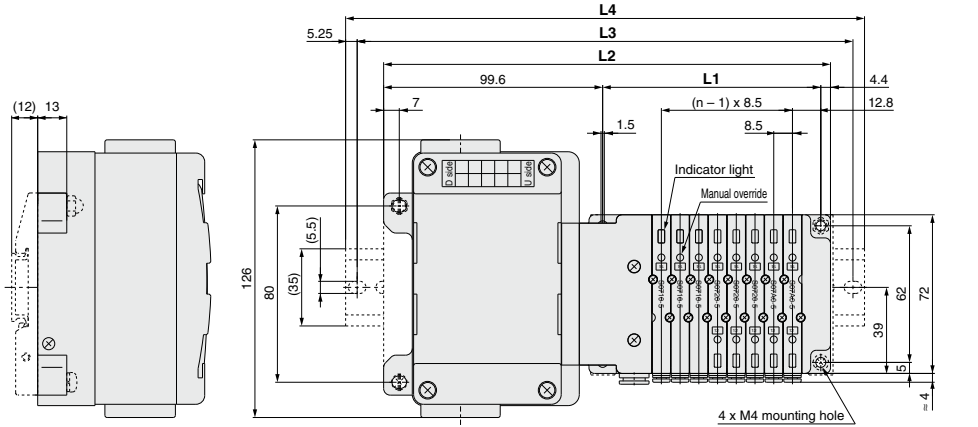

D side (Stations) ① ② ③ ④ ⑤ ⑥ ⑦ ⑧ ⑨ U side

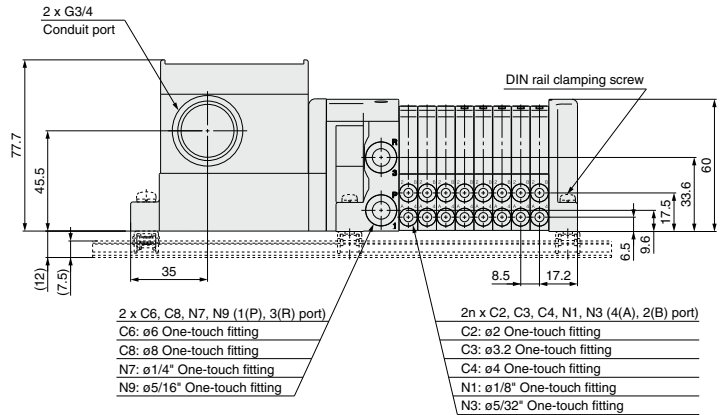

Dimensions

Formula L1 = 8.5n + 31, L2 = 8.5n + 135 n: Station (Maximum 20 stations)

| L \ n | 2 | 3 | 4 | 5 | 6 | 7 | 8 | 9 | 10 | 11 | 12 | 13 | 14 | 15 | 16 | 17 | 18 | 19 | 20 |
|-------|-------|-------|-------|-------|-------|-------|-------|-------|-------|-------|-------|-------|-------|-------|-------|-------|-------|-------|-------|
| L1 | 48 | 56.5 | 65 | 73.5 | 82 | 90.5 | 99 | 107.5 | 116 | 124.5 | 133 | 141.5 | 150 | 158.5 | 167 | 175.5 | 184 | 192.5 | 201 |
| L2 | 152 | 160.5 | 169 | 177.5 | 186 | 194.5 | 203 | 211.5 | 220 | 228.5 | 237 | 245.5 | 254 | 262.5 | 271 | 279.5 | 288 | 296.5 | 305 |
| L3 | 175 | 187.5 | 200 | 200 | 212.5 | 225 | 225 | 237.5 | 250 | 250 | 262.5 | 275 | 275 | 287.5 | 300 | 300 | 312.5 | 325 | 325 |
| L4 | 185.5 | 198 | 210.5 | 210.5 | 223 | 235.5 | 235.5 | 248 | 260.5 | 260.5 | 273 | 285.5 | 285.5 | 298 | 310.5 | 310.5 | 323 | 335.5 | 335.5 |

Plug-in Type Stacking Base

Lead Wire

L Kit



| |
|-------|
| SJ |
| SY |
| SY |
| S0700 |
| S0700 |

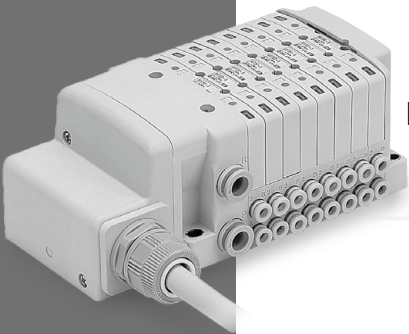

Lead Wire Direct Entry Type

→ Page 706

Plug-in Type

L S0700 Series Stacking Base Kit (Lead Wire)

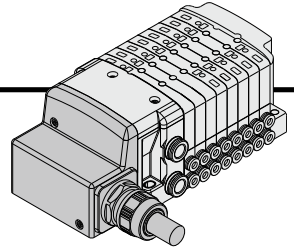

● Direct electrical entry type

Electrical Wiring Specifications

Lead wire specifications

Lead wire

0.3 mm² x 25 cores

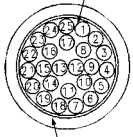

Sheath
Color: White

As the standard electrical wiring specifications, double wiring (connected to SOL. A and SOL. B) is adopted for the internal wiring of each station for 12 stations or less, regardless of valve and option types. Mixed single and double wiring is available as an option. For details, refer to Special Wiring Specifications (Option) below.

| | Terminal no. | Polarity | Lead wire color | Dot marking |
|------------|--------------|----------|-----------------|-------------|
| Station 1 | SOL.A 1 | (-) (+) | Black | None |
| | SOL.B 14 | (-) (+) | Yellow | Black |
| Station 2 | SOL.A 2 | (-) (+) | Brown | None |
| | SOL.B 15 | (-) (+) | Pink | Black |
| Station 3 | SOL.A 3 | (-) (+) | Red | None |
| | SOL.B 16 | (-) (+) | Blue | White |
| Station 4 | SOL.A 4 | (-) (+) | Orange | None |
| | SOL.B 17 | (-) (+) | Purple | None |
| Station 5 | SOL.A 5 | (-) (+) | Yellow | None |
| | SOL.B 18 | (-) (+) | Gray | None |
| Station 6 | SOL.A 6 | (-) (+) | Pink | None |
| | SOL.B 19 | (-) (+) | Orange | Black |
| Station 7 | SOL.A 7 | (-) (+) | Blue | None |
| | SOL.B 20 | (-) (+) | Red | White |
| Station 8 | SOL.A 8 | (-) (+) | Purple | White |
| | SOL.B 21 | (-) (+) | Brown | White |
| Station 9 | SOL.A 9 | (-) (+) | Gray | Black |
| | SOL.B 22 | (-) (+) | Pink | Red |
| Station 10 | SOL.A 10 | (-) (+) | White | Black |
| | SOL.B 23 | (-) (+) | Gray | Red |
| Station 11 | SOL.A 11 | (-) (+) | White | Red |
| | SOL.B 24 | (-) (+) | Black | White |
| Station 12 | SOL.A 12 | (-) (+) | Yellow | Red |
| | SOL.B 25 | (-) (+) | White | None |
| | COM. 13 | (+) (-) | Orange | Red |

Positive Negative*1
COM COM

*1: Mounting valve has no polarity. It can also be used as a negative common.

Lead wire length

SS0750 - 08 C4 LD 0

Lead wire length

| | |
|---|-------|
| 0 | 0.6 m |
| 1 | 1.5 m |
| 2 | 3.0 m |

Electrical Characteristics

| Item | Property |
|--------------------------------------|------------|
| Conductor resistance Ω/km, 20°C | 65 or less |
| Voltage limit V, 1 min, AC | 1000 |
| Insulation resistance MΩ/km, 20°C | 5 or more |

*1: Cannot be used for movable wiring. The minimum bending inner radius of cable is 20 mm.

Special Wiring Specifications (Option) [-K]

Mixed single and double wiring are available as an option. The maximum number of manifold stations is determined by the number of solenoids. Count one point for a single solenoid type and two points for a double solenoid type. The total number of solenoids (points) must not exceed 24.

1. How to Order valves

Indicate an option symbol, -K, for the manifold part number and be sure to specify the mounting position and number of stations of the single and double wiring on the manifold specification sheet.

2. Wiring specifications

Connector terminal numbers are connected from solenoid station 1 on the A side in the order indicated by the arrows without skipping any terminal numbers.



How to Order Manifold

SS0750-08 C4 C8 LD0-B

Stations

| Symbol | Stations |
|--------|-------------|
| 01 | 1 station |
| ⋮ | ⋮ |
| 24 | 24 stations |

*: The maximum number of stations will be different depending on the wiring specifications.

Cylinder port size

| Symbol | Port size | |
|--------|----------------------------------|--------|
| C2 | With ø2 One-touch fitting | Metric |
| C3 | With ø3.2 One-touch fitting | |
| C4 | With ø4 One-touch fitting | |
| CM | Mixed sizes and with port plug*1 | Inch |
| N1 | With ø1/8" One-touch fitting | |
| N3 | With ø5/32" One-touch fitting | |
| NM | Mixed sizes and with port plug*1 | |

*1: Specify "Mixed sizes and with port plug" on the manifold specification sheet.

P, R port size

| Symbol | Port size | |
|--------|-------------------------------|--------|
| C6 | With ø6 One-touch fitting | Metric |
| C8 | With ø8 One-touch fitting | |
| N7 | With ø1/4" One-touch fitting | Inch |
| N9 | With ø5/16" One-touch fitting | |

*: If an inch size cylinder port is selected, select inch size piping connections for the P and R ports as well.

Option

| Symbol | Specifications |
|--------|--|
| Nil | None |
| B-1 | With back pressure check valve (All stations) |
| D | With DIN rail (Rail length: Standard) |
| D0 | Without DIN rail (With bracket) |
| D□*2 | With DIN rail Designated length (□: Station) |
| K*3 | Special wiring specifications (Except double wiring) |
| N | With name plate |
| R*4 | External pilot |
| S | Built-in silencer |

*1: When installing a back pressure check valve on the required station, enter the part number and specify the station position on the manifold specification sheet.

*2: The available number of stations is larger than the number of manifold stations.

*3: Indicate the wiring specifications for mixed single and double wirings.

*4: For details, refer to page 718.

*: When two or more options are specified, indicate them alphabetically. Example) -BKN

*: For manifold optional parts, refer to pages 718 to 724.

*: For manifold exploded view, refer to page 714.

Kit type/Cable length

| Kit type | Symbol | Specifications | Standard station | Max. number of stations for special wiring specifications | Max. number of solenoids |
|----------|--------|-----------------------------|------------------|---|--------------------------|
| L kit | LD0 | Lead wire, with 0.6 m cable | 1 to 12 stations | 24 stations | 24 |
| | LD1 | Lead wire, with 1.5 m cable | | | |
| | LD2 | Lead wire, with 3.0 m cable | | | |

*: The maximum number of stations is determined by the total number of solenoids. For mixed single and double wirings, enter -K to the order code options.

| Type of actuation | Single | Double, Dual 3-port |
|---------------------|--------|---------------------|
| Number of solenoids | 1 | 2 |

How to Order Valves

S07 1 0 □ - 5

Type of actuation

| Symbol | Specifications |
|--------|--|
| 1 | 2-position single |
| 2 | 2-position double |
| A | 4-position dual 3-port (N.C. + N.C.) [Exhaust center] |
| B | 4-position dual 3-port (N.O. + N.O.) [Pressure center] |
| C | 4-position dual 3-port (N.C. + N.O.) |

*: For symbol, refer to page 652.

Voltage

| Symbol | Specifications |
|--------|----------------|
| 5 | 24 VDC |
| 6 | 12 VDC |

Function

| Symbol | Specifications |
|--------|------------------|
| Nil | Standard |
| R | External pilot*1 |

*1: Not compatible with dual 3-port valves. The 3(R) port is open to the atmosphere. (Cannot be used for applying pressure or vacuum)

Base mounted plug-in

How to Order Manifold Assembly

Example Lead wire kit

Specify the part numbers for valves and options together beneath the manifold base part number.

SS0750-08C4C8LD0... 1 set - Manifold base part no.
 * S0710-5 3 sets - Valve part no. (Stations 1 to 3)
 * S0720-5 2 sets - Valve part no. (Stations 4 to 5)
 * S07A0-5 2 sets - Valve part no. (Stations 6 to 7)
 * SS0700-10A-1 1 set - Blanking plate part no. (Station 8)

Prefix the asterisk to the part numbers of the solenoid valve etc. Write sequentially from the 1st station on the D side. When part numbers written collectively are complicated, specify on the manifold specification sheet.

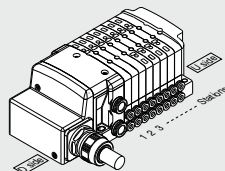

S0700 Series Kit (Lead Wire)

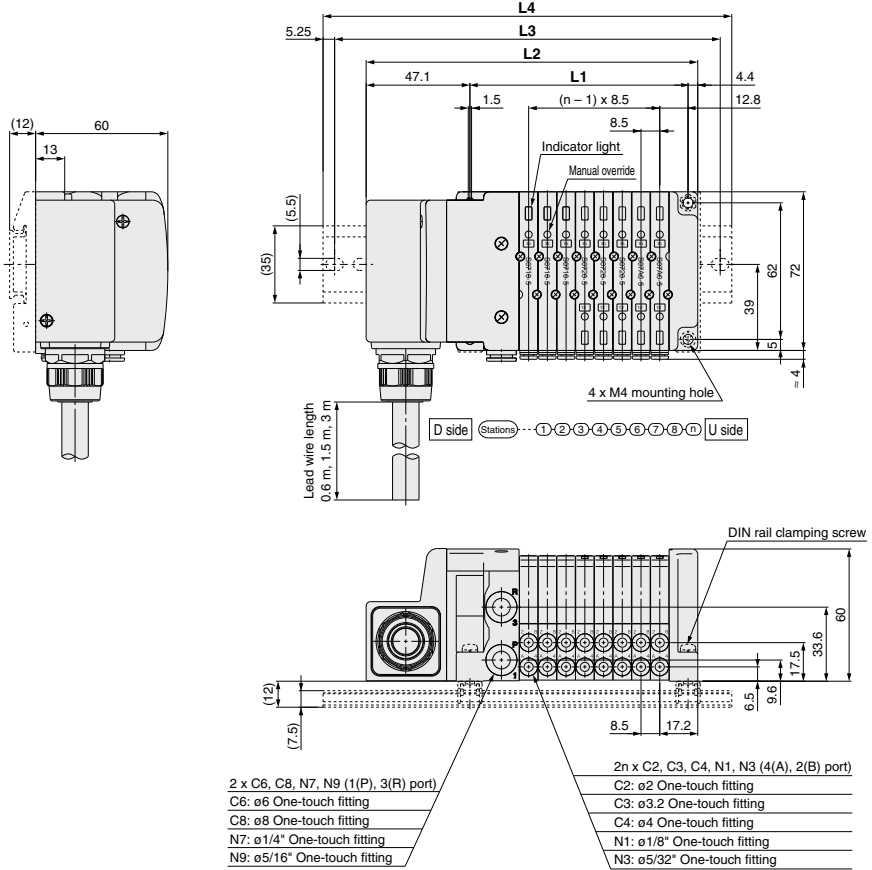

Dimensions

Formula $L1 = 8.5n + 31$, $L2 = 8.5n + 82.5$ n: Station (Maximum 24 stations)

| L \ n | 2 | 3 | 4 | 5 | 6 | 7 | 8 | 9 | 10 | 11 | 12 | 13 | 14 | 15 | 16 | 17 | 18 | 19 | 20 | 21 | 22 | 23 | 24 |
|-----------|-------|-------|-------|-------|-------|-------|-------|-------|-------|-------|-------|-------|-------|-------|-------|-------|-------|-------|-------|-------|-------|-------|-------|
| L1 | 48 | 56.5 | 65 | 73.5 | 82 | 90.5 | 99 | 107.5 | 116 | 124.5 | 133 | 141.5 | 150 | 158.5 | 167 | 175.5 | 184 | 192.5 | 201 | 209.5 | 218 | 226.5 | 235 |
| L2 | 99.5 | 108 | 116.5 | 125 | 133.5 | 142 | 150.5 | 159 | 167.5 | 176 | 184.5 | 193 | 201.5 | 210 | 218.5 | 227 | 235.5 | 244 | 252.5 | 261 | 269.5 | 278 | 286.5 |
| L3 | 125 | 137.5 | 137.5 | 150 | 162.5 | 162.5 | 175 | 187.5 | 187.5 | 200 | 212.5 | 212.5 | 225 | 237.5 | 250 | 250 | 262.5 | 275 | 287.5 | 300 | 300 | 312.5 | 312.5 |
| L4 | 135.5 | 148 | 148 | 160.5 | 173 | 173 | 185.5 | 198 | 198 | 210.5 | 223 | 223 | 235.5 | 248 | 260.5 | 260.5 | 273 | 285.5 | 285.5 | 298 | 310.5 | 310.5 | 323 |

Plug-in Type Stacking Base

Circular Connector

M Kit



SJ

SY

SY

S0700

S0700

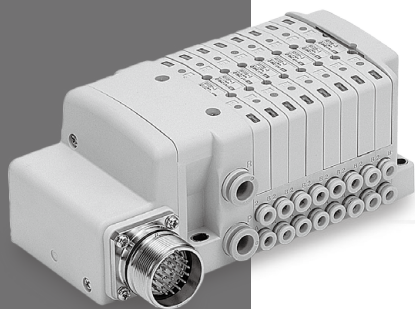

Circular Connector 26 Pins

Page 710

Plug-in Type

M S0700 Series Stacking Base Kit (Circular Connector)

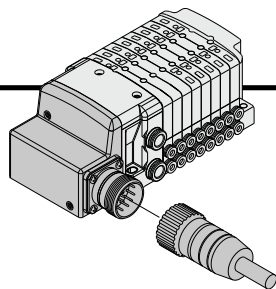

- Simplification and labor savings for wiring work can be achieved by using a circular connector for the electrical connection.

Electrical Wiring Specifications

Circular connector

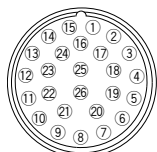

Double wiring (connected to SOL. A and SOL. B) is adopted for the internal wiring of each station, regardless of valve and option types.

Mixed single and double wiring is available as an option. For details, refer to Special Wiring Specifications (Option) below.

| | Terminal no. | Polarity |
|------------|--------------|------------|
| Station 1 | SOL.A | 1 (-) (+) |
| | SOL.B | 2 (-) (+) |
| Station 2 | SOL.A | 3 (-) (+) |
| | SOL.B | 4 (-) (+) |
| Station 3 | SOL.A | 5 (-) (+) |
| | SOL.B | 6 (-) (+) |
| Station 4 | SOL.A | 7 (-) (+) |
| | SOL.B | 8 (-) (+) |
| Station 5 | SOL.A | 9 (-) (+) |
| | SOL.B | 10 (-) (+) |
| Station 6 | SOL.A | 11 (-) (+) |
| | SOL.B | 12 (-) (+) |
| Station 7 | SOL.A | 13 (-) (+) |
| | SOL.B | 14 (-) (+) |
| Station 8 | SOL.A | 15 (-) (+) |
| | SOL.B | 16 (-) (+) |
| Station 9 | SOL.A | 17 (-) (+) |
| | SOL.B | 18 (-) (+) |
| Station 10 | SOL.A | 19 (-) (+) |
| | SOL.B | 20 (-) (+) |
| Station 11 | SOL.A | 21 (-) (+) |
| | SOL.B | 22 (-) (+) |
| Station 12 | SOL.A | 23 (-) (+) |
| | SOL.B | 24 (-) (+) |
| | COM. | 25 (+) (-) |
| | COM. | 26 (+) (-) |

Positive COM Negative¹ COM

*1: Mounting valve has no polarity. It can also be used as a negative common.

Special Wiring Specifications (Option) [-K]

Mixed single and double wiring are available as an option. The maximum number of manifold stations is determined by the number of solenoids. Count one point for a single solenoid type and two points for a double solenoid type. The total number of solenoids (points) must not exceed 24.

1. How to Order valves

Indicate an option symbol, -K, for the manifold part number and be sure to specify the mounting position and number of stations of the single and double wiring on the manifold specification sheet.

2. Wiring specifications

Connector terminal numbers are connected from solenoid station 1 on the A side in the order indicated by the arrows without skipping any terminal numbers.

Cable Assembly

AXT100-MC26-030
050

(Circular connector assembly (26P type) can be included in a specific manifold model number. Refer to How to Order Manifold.)

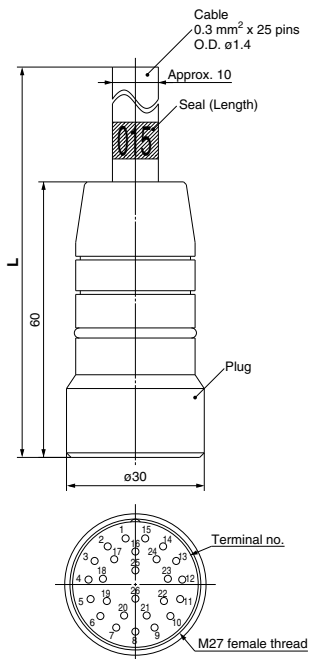

Circular Connector Cable Assembly (Option)

| Cable length (L) | Assembly part no. |
|------------------|-------------------|
| | 26P |
| 1.5 m | AXT100-MC26-015 |
| 3 m | AXT100-MC26-030 |
| 5 m | AXT100-MC26-050 |

*: Cannot be used for movable wiring.



How to Order Manifold

SS0750-08 C4 C8 MD1-B

Stations

| Symbol | Stations |
|--------|-------------|
| 01 | 1 station |
| ⋮ | ⋮ |
| 24*1 | 24 stations |

*1: The maximum number of stations will be different depending on the wiring specifications.

Cylinder port size

| Symbol | Port size | |
|--------|----------------------------------|--------|
| C2 | With ø2 One-touch fitting | Metric |
| C3 | With ø3.2 One-touch fitting | |
| C4 | With ø4 One-touch fitting | |
| CM | Mixed sizes and with port plug*1 | |
| N1 | With ø1/8" One-touch fitting | Inch |
| N3 | With ø5/32" One-touch fitting | |
| NM | Mixed sizes and with port plug*1 | |

*1: Specify Mixed sizes and with port plug on the manifold specification sheet.

P, R port size

| Symbol | Port size | |
|--------|-------------------------------|--------|
| C6 | With ø6 One-touch fitting | Metric |
| C8 | With ø8 One-touch fitting | |
| N7 | With ø1/4" One-touch fitting | Inch |
| N9 | With ø5/16" One-touch fitting | |

*: If an inch size cylinder port is selected, select inch size piping connections for the P and R ports as well.

Option

| Symbol | Specifications |
|--------|--|
| Nll | None |
| B*1 | With back pressure check valve (All stations) |
| D | With DIN rail (Rail length: Standard) |
| D0 | Without DIN rail (With bracket) |
| D□*2 | With DIN rail Designated length (□: Station) |
| K*3 | Special wiring specifications (Except double wiring) |
| N | With name plate |
| R*4 | External pilot |
| S | Built-in silencer |

*1: When installing a back pressure check valve on the required station, enter the part number and specify the station position on the manifold specification sheet.

*2: The available number of stations is larger than the number of manifold stations.

*3: Indicate the wiring specifications for mixed single and double wirings.

*4: For details, refer to page 718.

*: When two or more options are specified, indicate them alphabetically. Example) -BKN

*: For manifold optional parts, refer to pages 718 to 724.

*: For manifold exploded view, refer to page 714.

Kit type/Cable length

| Kit type | Symbol | Specifications | Standard station | Max. number of stations for special wiring specifications | Max. number of solenoids |
|----------|--------|--|------------------|---|--------------------------|
| M kit | MD0 | Circular connector (26P), without cable | 1 to 12 stations | 24 stations | 24 |
| | MD1 | Circular connector (26P), with 1.5 m cable | | | |
| | MD2 | Circular connector (26P), with 3.0 m cable | | | |
| | MD3 | Circular connector (26P), with 5.0 m cable | | | |

*: The maximum number of stations is determined by the total number of solenoids. For mixed single and double wirings, enter -K to the order code options.

| Type of actuation | Single | Double, Dual 3-port |
|---------------------|--------|---------------------|
| Number of solenoids | 1 | 2 |

How to Order Valves

S07 1 0 □ - 5

Type of actuation

| Symbol | Specifications |
|--------|--|
| 1 | 2-position single |
| 2 | 2-position double |
| A | 4-position dual 3-port (N.C. + N.C.) [Exhaust center] |
| B | 4-position dual 3-port (N.O. + N.O.) [Pressure center] |
| C | 4-position dual 3-port (N.C. + N.O.) |

*: For symbol, refer to page 652.

Voltage

| Symbol | Specifications |
|--------|----------------|
| 5 | 24 VDC |
| 6 | 12 VDC |

Function

| Symbol | Specifications |
|--------|------------------|
| Nll | Standard |
| R | External pilot*1 |

*1: Not compatible with dual 3-port valves. The 3(R) port is open to the atmosphere. (Cannot be used for applying pressure or vacuum)

Base mounted plug-in

How to Order Manifold Assembly

Example Circular connector kit

Specify the part numbers for valves and options together beneath the manifold base part number.

SS0750-08C4C8MD1-... 1 set - Manifold base part no.
 * S0710-5 3 sets - Valve part no. (Stations 1 to 3)
 * S0720-5 2 sets - Valve part no. (Stations 4 to 5)
 * S07A0-5 2 sets - Valve part no. (Stations 6 to 7)
 * SS0700-10A-1 1 set - Blanking plate part no. (Station 8)

Prefix the asterisk to the part numbers of the solenoid valve etc. Write sequentially from the 1st station on the D side. When part numbers written collectively are complicated, specify on the manifold specification sheet.

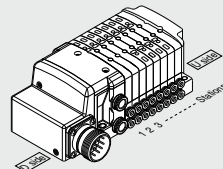



S0700 Series Kit (Circular Connector)

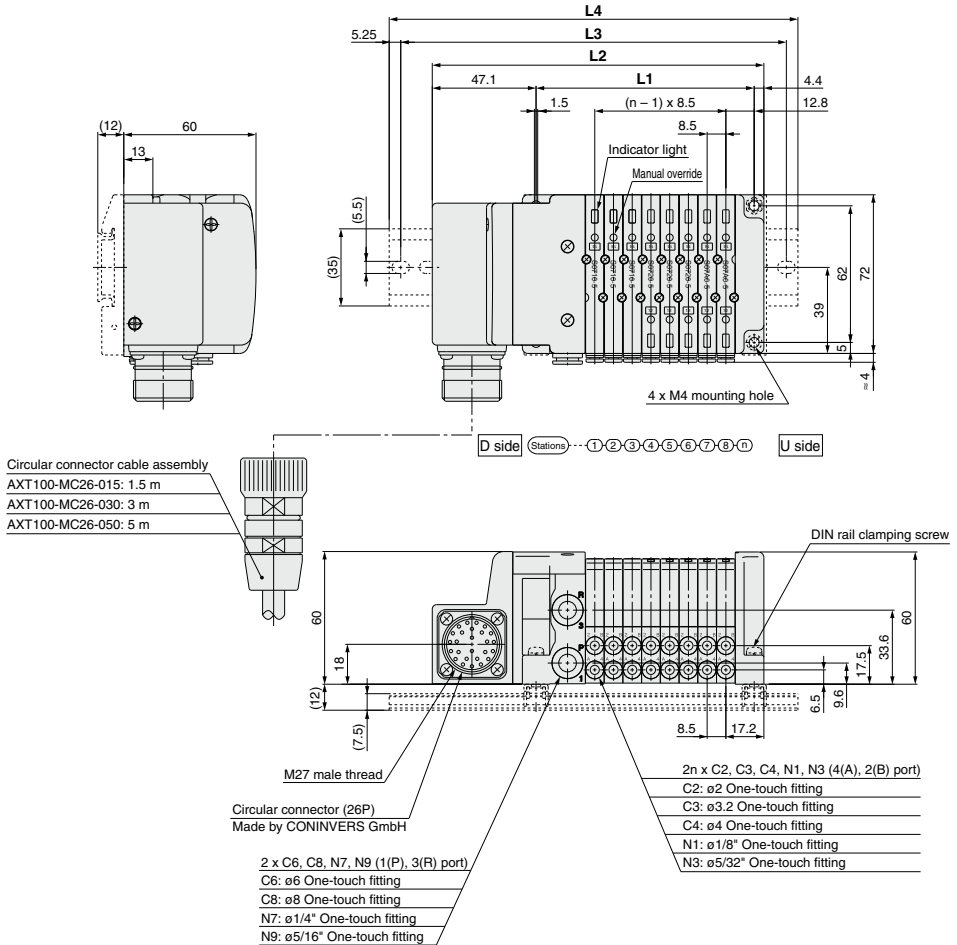

Dimensions

Formula L1 = 8.5n + 31, L2 = 8.5n + 82.5 n: Station (Maximum 24 stations)

| L \ n | 2 | 3 | 4 | 5 | 6 | 7 | 8 | 9 | 10 | 11 | 12 | 13 | 14 | 15 | 16 | 17 | 18 | 19 | 20 | 21 | 22 | 23 | 24 |
|-----------|-------|-------|-------|-------|-------|-------|-------|-------|-------|-------|-------|-------|-------|-------|-------|-------|-------|-------|-------|-------|-------|-------|-------|
| L1 | 48 | 56.5 | 65 | 73.5 | 82 | 90.5 | 99 | 107.5 | 116 | 124.5 | 133 | 141.5 | 150 | 158.5 | 167 | 175.5 | 184 | 192.5 | 201 | 209.5 | 218 | 226.5 | 235 |
| L2 | 99.5 | 108 | 116.5 | 125 | 133.5 | 142 | 150.5 | 159 | 167.5 | 176 | 184.5 | 193 | 201.5 | 210 | 218.5 | 227 | 235.5 | 244 | 252.5 | 261 | 269.5 | 278 | 286.5 |
| L3 | 125 | 137.5 | 137.5 | 150 | 162.5 | 162.5 | 175 | 187.5 | 187.5 | 200 | 212.5 | 225 | 237.5 | 250 | 250 | 262.5 | 275 | 275 | 287.5 | 300 | 300 | 312.5 | 312.5 |
| L4 | 135.5 | 148 | 148 | 160.5 | 173 | 173 | 185.5 | 198 | 198 | 210.5 | 223 | 223 | 235.5 | 248 | 260.5 | 260.5 | 273 | 285.5 | 285.5 | 298 | 310.5 | 310.5 | 323 |

Construction

Single: S0710

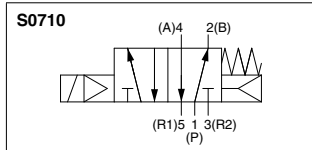
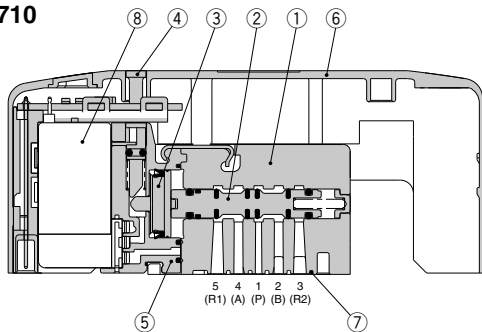

Double: S0720

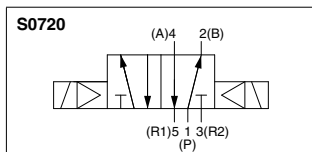
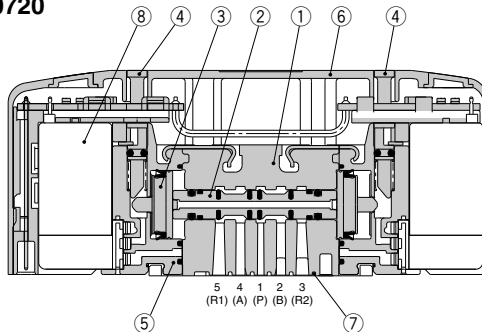

Dual 3-Port: S07B0

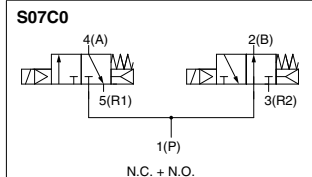
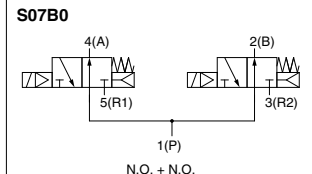
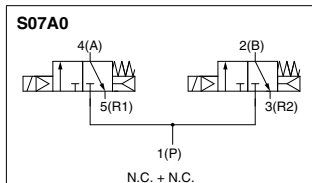
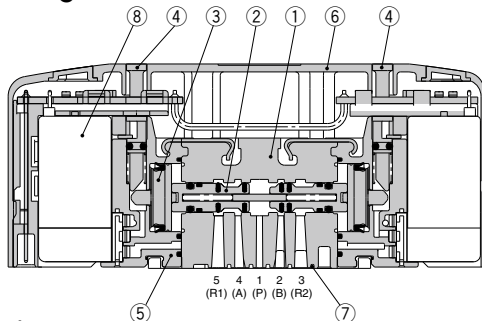

Component Parts

| No. | Description | Material |
|-----|------------------------|-----------------|
| 1 | Body | Zinc die-casted |
| 2 | Spool | Aluminum |
| 3 | Piston | Resin |
| 4 | Manual override | Resin |
| 5 | Adapter plate | Resin |
| 6 | Cover | Resin |
| 7 | Interface gasket | HNBR |
| 8 | Pilot valve assembly*1 | — |

*1: Please consult with SMC for pilot valve replacement.

SJ
SY
SY
S0700
S0700

Plug-in Type Stacking Base S0700 Series Manifold Exploded View

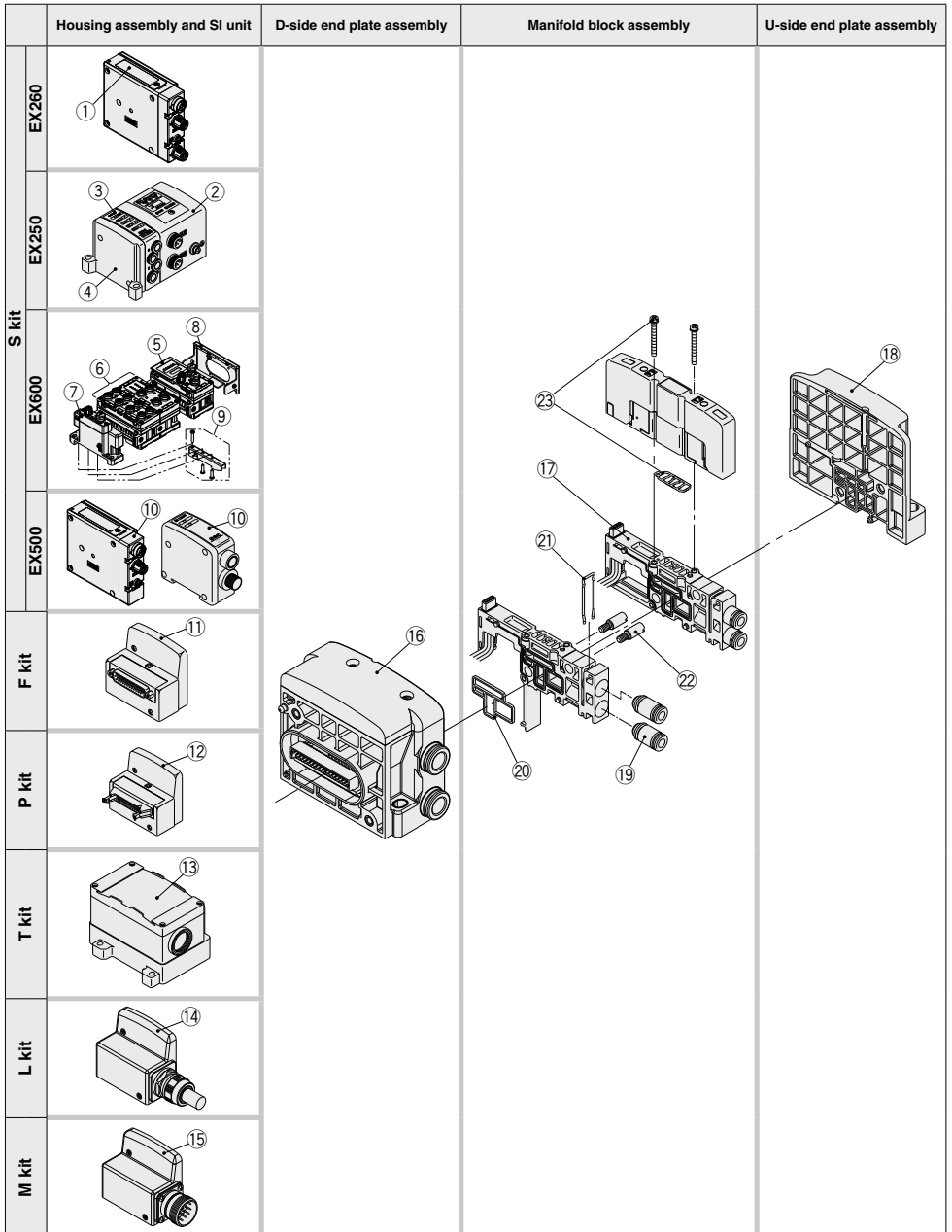

Note that the EX250-SPR1 PROFIBUS DP compatible SI unit is to be discontinued as of November 2022.

Note that EX600 series EtherCAT compatible SI units (EX600-SEC1 and EX600-SEC2) are to be discontinued as of October 2022.

Manifold Assembly Part No.

<Housing Assembly and SI Unit, Input Block>

| No. | Description | Part no. | Note | | |
|--------------------------|--|--------------------------|---|------------|--|
| ① | EX260 SI unit | EX260-SDN1 | DeviceNet® M12 connector, 32 outputs, PNP (Negative common) | | |
| | | EX260-SDN2 | DeviceNet® M12 connector, 32 outputs, NPN (Positive common) | | |
| | | EX260-SDN3 | DeviceNet® M12 connector, 16 outputs, PNP (Negative common) | | |
| | | EX260-SDN4 | DeviceNet® M12 connector, 16 outputs, NPN (Positive common) | | |
| | | EX260-SPR1 | PROFIBUS DP M12 connector, 32 outputs, PNP (Negative common) | | |
| | | EX260-SPR2 | PROFIBUS DP M12 connector, 32 outputs, NPN (Positive common) | | |
| | | EX260-SPR3 | PROFIBUS DP M12 connector, 16 outputs, PNP (Negative common) | | |
| | | EX260-SPR4 | PROFIBUS DP M12 connector, 16 outputs, NPN (Positive common) | | |
| | | EX260-SPR5 | PROFIBUS DP D-sub connector, 32 outputs, PNP (Negative common) | | |
| | | EX260-SPR6 | PROFIBUS DP D-sub connector, 32 outputs, NPN (Positive common) | | |
| | | EX260-SPR7 | PROFIBUS DP D-sub connector, 16 outputs, PNP (Negative common) | | |
| | | EX260-SPR8 | PROFIBUS DP D-sub connector, 16 outputs, NPN (Positive common) | | |
| | | EX260-SMJ1 | CC-Link M12 connector, 32 outputs, PNP (Negative common) | | |
| | | EX260-SMJ2 | CC-Link M12 connector, 32 outputs, NPN (Positive common) | | |
| | | EX260-SMJ3 | CC-Link M12 connector, 16 outputs, PNP (Negative common) | | |
| | | EX260-SMJ4 | CC-Link M12 connector, 16 outputs, NPN (Positive common) | | |
| | | EX260-SEC1 | EtherCAT M12 connector, 32 outputs, PNP (Negative common) | | |
| | | EX260-SEC2 | EtherCAT M12 connector, 32 outputs, NPN (Positive common) | | |
| | | EX260-SEC3 | EtherCAT M12 connector 16 outputs, PNP (Negative common) | | |
| | | EX260-SEC4 | EtherCAT M12 connector, 16 outputs, NPN (Positive common) | | |
| | | EX260-SPN1 | PROFINET M12 connector, 32 outputs, PNP (Negative common) | | |
| | | EX260-SPN2 | PROFINET M12 connector, 32 outputs, NPN (Positive common) | | |
| | | EX260-SPN3 | PROFINET M12 connector, 16 outputs, PNP (Negative common) | | |
| | | EX260-SPN4 | PROFINET M12 connector, 16 outputs, NPN (Positive common) | | |
| | | EX260-SEN1 | EtherNet/IP™ M12 connector, 32 outputs, PNP (Negative common) | | |
| | | EX260-SEN2 | EtherNet/IP™ M12 connector, 32 outputs, NPN (Positive common) | | |
| | | EX260-SEN3 | EtherNet/IP™ M12 connector 16 outputs, PNP (Negative common) | | |
| | | EX260-SEN4 | EtherNet/IP™ M12 connector, 16 outputs, NPN (Positive common) | | |
| | | EX260-SPL1 | Ethernet POWERLINK M12 connector, 32 outputs, PNP (Negative common) | | |
| | | EX260-SPL3 | Ethernet POWERLINK M12 connector, 16 outputs, PNP (Negative common) | | |
| | | ② | EX250 SI unit | EX250-SDN1 | DeviceNet® PNP (Negative common) |
| | | | | EX250-SPR1 | PROFIBUS DP PNP (Negative common) |
| | | | | EX250-SAS3 | AS-Interface 31 slave, 8 in/8 out, 2 isolated common type, PNP (Negative common) |
| EX250-SAS5 | AS-Interface 31 slave, 4 in/4 out, 2 isolated common type, PNP (Negative common) | | | | |
| EX250-SAS7 | AS-Interface 31 slave, 8 in/8 out, 1 common type, PNP (Negative common) | | | | |
| EX250-SAS9 | AS-Interface 31 slave, 4 in/4 out, 1 common type, PNP (Negative common) | | | | |
| EX250-SCA1A | CANopen PNP (Negative common) | | | | |
| EX250-SEN1 | EtherNet/IP™ PNP (Negative common) | | | | |
| ③ | EX250 input block | | | EX250-IE1 | M12 2 inputs |
| | | | | EX250-IE2 | M12 4 inputs |
| | | EX250-IE3 | M8 4 inputs | | |
| ④ | EX250 end plate assembly | EX250-EA1 | Direct mounting | | |
| | | EX250-EA2 | DIN rail mounting | | |
| ⑤ | EX600 SI unit | EX600-SDN1A | DeviceNet® PNP (Negative common) | | |
| | | EX600-SDN2A | DeviceNet® NPN (Positive common) | | |
| | | EX600-SMJ1 | CC-Link PNP (Negative common) | | |
| | | EX600-SMJ2 | CC-Link NPN (Positive common) | | |
| | | EX600-SPR1A | PROFIBUS DP PNP (Negative common) | | |
| | | EX600-SPR2A | PROFIBUS DP NPN (Positive common) | | |
| | | EX600-SEN1 | EtherNet/IP™ (1 port) PNP (Negative common) | | |
| | | EX600-SEN2 | EtherNet/IP™ (1 port) NPN (Positive common) | | |
| | | EX600-SEN3 | EtherNet/IP™ (2 ports) PNP (Negative common) | | |
| | | EX600-SEN4 | EtherNet/IP™ (2 ports) NPN (Positive common) | | |
| | | EX600-SPN1 | PROFINET PNP (Negative common) | | |
| | | EX600-SPN2 | PROFINET NPN (Positive common) | | |
| | | EX600-SEC1 | EtherCAT PNP (Negative common) | | |
| | | EX600-SEC2 | EtherCAT NPN (Positive common) | | |
| | | EX600-WEN1 ^{*1} | Wireless base module EtherNet/IP™ PNP (Negative common) | | |
| | | EX600-WEN2 ^{*1} | Wireless base module EtherNet/IP™ NPN (Positive common) | | |
| | | EX600-WPN1 ^{*1} | Wireless base module PROFINET PNP (Negative common) | | |
| | | EX600-WPN2 ^{*1} | Wireless base module PROFINET NPN (Positive common) | | |
| | | EX600-WSV1 ^{*1} | Wireless remote module PNP (Negative common) | | |
| EX600-WSV2 ^{*1} | Wireless remote module NPN (Positive common) | | | | |
| ⑥ | EX600 digital input unit | EX600-DXNB | NPN input, M12 connector, 5 pins (4 pcs.), 8 inputs | | |
| | | EX600-DXPB | PNP input, M12 connector, 5 pins (4 pcs.), 8 inputs | | |
| | | EX600-DXNC | NPN input, M8 connector, 3 pins (8 pcs.), 8 inputs | | |
| | | EX600-DXNC1 | NPN input, M8 connector, 3 pins (8 pcs.), 8 inputs, with open circuit detection | | |
| | | EX600-DXPC | PNP input, M8 connector, 3 pins (8 pcs.), 8 inputs | | |
| | | EX600-DXPC1 | PNP input, M8 connector, 3 pins (8 pcs.), 8 inputs, with open circuit detection | | |
| | | EX600-DXND | NPN input, M12 connector, 5 pins (8 pcs.), 16 inputs | | |
| | | EX600-DXPD | PNP input, M12 connector, 5 pins (8 pcs.), 16 inputs | | |
| | | EX600-DXNE | NPN input, D-sub connector, 25 pins, 16 inputs | | |
| | | EX600-DXPE | PNP input, D-sub connector, 25 pins, 16 inputs | | |
| | | EX600-DXNF | NPN input, Spring type terminal block, 32 pins, 16 inputs | | |
| EX600-DXPF | PNP input, Spring type terminal block, 32 pins, 16 inputs | | | | |

*1: The wireless system is suitable for use only in a country where it is in accordance with the Radio Act and regulations of that country.

SJ
SY
SY
S0700
S0700

S0700 Series

Manifold Assembly Part No.

<Housing Assembly and SI Unit, Input Block>

| No. | Description | Part no. | Note |
|-------------|---|------------------|---|
| ⑥ | EX600 digital output unit | EX600-DYNB | NPN output, M12 connector, 5 pins (4 pcs.), 8 outputs |
| | | EX600-DYPB | PNP output, M12 connector, 5 pins (4 pcs.), 8 outputs |
| | | EX600-DYNE | NPN output, D-sub connector, 25 pins, 16 outputs |
| | | EX600-DYPE | PNP output, D-sub connector, 25 pins, 16 outputs |
| | | EX600-DYNF | NPN output, Spring type terminal block, 32 pins, 16 outputs |
| | EX600 digital I/O unit | EX600-DYPE | PNP output, Spring type terminal block, 32 pins, 16 outputs |
| | | EX600-DMNE | NPN input/output, D-sub connector, 25 pins, 8 inputs/outputs |
| | | EX600-DMPE | PNP input/output, D-sub connector, 25 pins, 8 inputs/outputs |
| | | EX600-DMNF | NPN input/output, Spring type terminal block, 32 pins, 8 inputs/outputs |
| | | EX600-DMPF | PNP input/output, Spring type terminal block, 32 pins, 8 inputs/outputs |
| ⑦ | EX600 analog input unit | EX600-AXA | M12 connector, 5 pins (2 pcs.), 2-channel input |
| | EX600 analog output unit | EX600-AYA | M12 connector, 5 pins (2 pcs.), 2-channel output |
| | EX600 analog I/O unit | EX600-AMB | M12 connector, 5 pins (4 pcs.), 2-channel input/output |
| | EX600 end plate | EX600-ED2 | M12 power supply connector, B-coded |
| | | EX600-ED2-2 | M12 power supply connector, B-coded, with DIN rail mounting bracket |
| | | EX600-ED3 | 7/8 inch power supply connector |
| | | EX600-ED3-2 | 7/8 inch power supply connector, with DIN rail mounting bracket |
| EX600-ED4 | M12 power supply connector IN/OUT, A-coded, Pin arrangement 1 | | |
| EX600-ED4-2 | M12 power supply connector IN/OUT, A-coded, Pin arrangement 1, with DIN rail mounting bracket | | |
| ⑧ | EX600 valve plate | EX600-ED5 | M12 power supply connector IN/OUT, A-coded, Pin arrangement 2 |
| | | EX600-ED5-2 | M12 power supply connector IN/OUT, A-coded, Pin arrangement 2, with DIN rail mounting bracket |
| | | EX600-ZMV1 | Enclosed parts: Round head screw (M4 x 6) 2 pcs, Round head screw (M3 x 8) 4 pcs. |
| | | EX600-ZMA2 | This bracket is used for the end plate of DIN rail mounting. |
| | | EX500-S103 | EX500 Gateway Decentralized System 2 Negative common (PNP) |
| ⑨ | EX600 bracket for end plate | EX500-Q001 | EX500 Gateway Decentralized System Positive common (PNP) |
| | | EX500-Q101 | EX500 Gateway Decentralized System Negative common (PNP) |
| ⑩ | EX500 SI unit | | |
| ⑪ | D-sub connector housing assembly | VVQC1000-F25-1 | F kit, 25 pins |
| ⑫ | Flat ribbon cable housing assembly | VVQC1000-P26-1 | P kit, 26 pins |
| | | VVQC1000-P20-1 | P kit, 20 pins |
| ⑬ | Terminal block box housing assembly | VVQC1000-T0-1 | T kit |
| ⑭ | Lead wire housing assembly | VVQC1000-L25-0-1 | L kit, Lead wire length 0.6 m |
| | | VVQC1000-L25-1-1 | L kit, Lead wire length 1.5 m |
| | | VVQC1000-L25-2-1 | L kit, Lead wire length 3.0 m |
| ⑮ | Circular connector housing assembly | VVQC1000-M26-1 | M kit, 26 pins |

⑮ D-side end plate assembly part no.

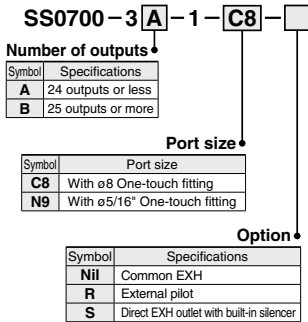

⑰ Manifold block assembly

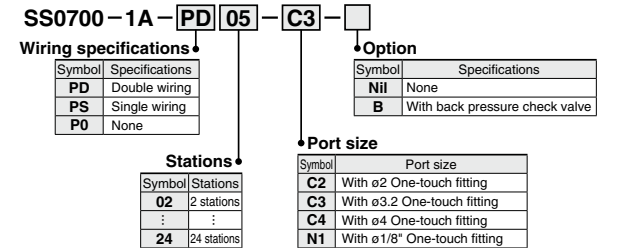

⑱ U-side end plate assembly part no.

SS0700 - 2A - 2

⑲ Fitting assembly part no.

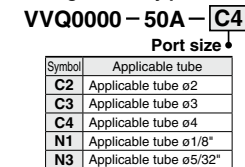

*: Purchasing order is available in units of 10 pieces.

*: For One-touch fittings replacement, refer to Specific Product Precautions.

<Replacement Parts for Manifold Block>

Replacement Parts

| No. | Description | Part no. | Qty. |
|-----|------------------|--------------|-----------------|
| ⑰ | Gasket | SS0700-80A-2 | 10 ¹ |
| ⑱ | Clip | SS0700-80A-4 | 10 ¹ |
| ⑳ | Tie-rod assembly | SS0700-TR-□ | 2 ² |

*1: 1 set includes 10 pieces.

*2: 1 set includes 2 pieces. Please order when eliminating manifold stations. When adding stations, tie-rods are attached to the manifold block assembly. Therefore, it is not necessary to order.

□: Stations 02 to 24

<Replacement Parts for Valve>

Replacement Parts

| No. | Description | Part no. | Qty. |
|-----|---------------|------------|------|
| ㉓ | Gasket, Screw | S0700-GS-5 | 10 |

*: Above part number consists of 10 units. Each unit has one gasket and two screws.

How to Add Manifold Stations (Plug-in Type/Lead Wire Connection Type)

What to order

- Manifold block assembly (Refer to ⑰ on page 716.)

Steps for adding stations

- ① Loosen hexagon bolts from the end plate at the U-side and remove the end plate.
- ② Connect the tie rod for increasing the station number, open the junction cover, mount the manifold block assembly and U-side end plate and tighten them by hexagon bolts.
(Tightening torque: 0.85 to 0.95 N·m)

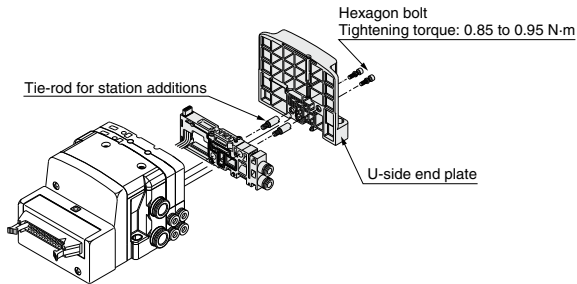

- ③ Connect the round type terminal of red lead wire to the common terminal inside the junction cover.

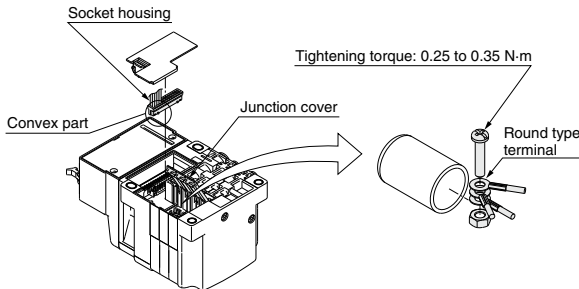

- ④ Take out the socket housing and connect the black and white lead wires.
The connection layout is common to all kits.

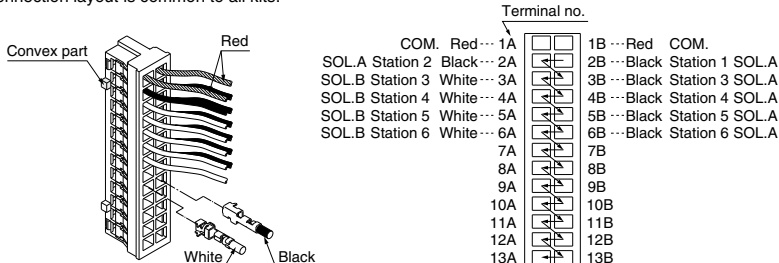

Note) This drawing shows a special wiring specification (K) manifold with single wiring for stations 1 and 2 and double wiring for stations 3 to 6.

Manifold Optional Parts

Slim Compact
Bar Base

Plug-in Type
Stacking Base

Blanking plate assembly

SS0700-10A-1/SS0700-10A-3

It is used by attaching on the manifold base for being prepared for removing a valve for maintenance reasons or planning to mount a valve, etc.

Weight: 25 g

| Applicable manifold | Part no. | Weight |
|----------------------------|---------------------|--------|
| Slim compact Bar base | SS0751 SS0700-10A-3 | 8 g |
| Plug-in type Stacking base | SS0750 SS0700-10A-1 | 25 g |

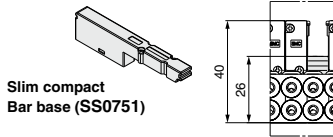

Slim compact Bar base (SS0751)

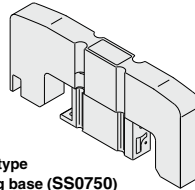

Plug-in type Stacking base (SS0750)

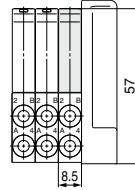

Slim Compact
Bar Base

Plug-in Type
Stacking Base

External pilot [-R]

This can be used when the air pressure is 0.1 to 0.2 MPa lower than the minimum operating pressure of the solenoid valves or used for vacuum specifications. Add -R to the part numbers of manifolds and valves to indicate the external pilot specifications. An M5 port will be installed on the top side of the manifold's SUP/EXH block.

●How to Order Valves (Example)

S071□ R -5
↓ External pilot

●How to Order Manifold (Example)

*: Indicate -R for an option.
SS075□-08C4FD1-R
↓ External pilot

External pilot port
(M5 x 0.8)

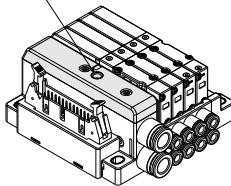

Slim compact Bar base (SS0751)

External pilot port
(M5 x 0.8)

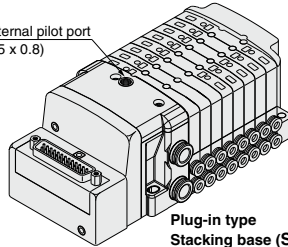

Plug-in type Stacking base (SS0750)

- *: Not compatible with dual 3-port valves.
- *: When the internal pilot type and external pilot type of valves are mixed up on the manifold, order the manifold suitable for the specifications of the external pilot valve.
- *: Valves with the external pilot have a pilot EXH with individual exhaust specifications and EXH can be pressurized. However, the pressure supplied from EXH should be 0.4 MPa or lower.

Slim Compact
Bar Base

Plug-in Type
Stacking Base

Direct EXH outlet with built-in silencer [-S]

This is a type with an exhaust port atop the manifold end plate. The built-in silencer exhibits an excellent noise suppression effect. (Noise reduction: 30 dB)

- *: A large quantity of drainage generated in the air source results in exhaust of air together with drainage.
- *: When ordering this option incorporated with a manifold, suffix -S to the end of the manifold part number.
- *: For precautions on handling and how to replace elements, refer to Specific Product Precautions.

Exhaust port

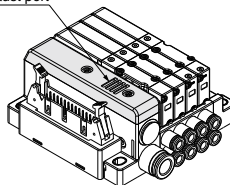

Slim compact Bar base (SS0751)

Exhaust port

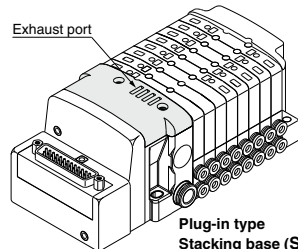

Plug-in type Stacking base (SS0750)

Plug-in Type
Stacking Base

Individual SUP/EXH spacer
SS0700-PR-1

If this spacer is installed instead of a valve, it is possible to add SUP and EXH ports. In this condition, the A port should be an SUP port and the B port an EXH port.

- *: Specify the spacer mounting position and SUP/EXH passage shut off positions on the manifold specification sheet.
- *: The spacer comes with a SUP block plate and an EXH block plate.
- *: Electrical wiring is also connected to the spacer mounting position.
- *: Do not install any back pressure check valve on the manifold station, on which the spacer is to be mounted. When installing the back pressure check valve on other manifold station, be sure to specify the manifold station position on the manifold specification sheet instead of ordering by specifying the manifold option symbol B.

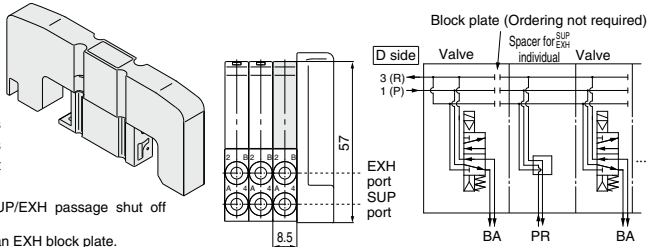

SJ
SY
SY
S0700
S0700

Slim Compact
Bar Base

Individual SUP spacer
SS0700-P-3-C4

Port size

| Symbol | Applicable tube |
|-----------|------------------------|
| C2 | Applicable tube ø2 |
| C3 | Applicable tube ø3 |
| C4 | Applicable tube ø4 |
| N1 | Applicable tube ø1/8" |
| N3 | Applicable tube ø5/32" |

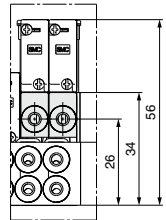
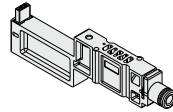

Mounted on the manifold block to make an independent supply port when each solenoid valve uses different operating pressure.

Weight: 15 g

Slim Compact
Bar Base

Individual EXH spacer
SS0700-R-3-C4

Port size

| Symbol | Applicable tube |
|-----------|------------------------|
| C2 | Applicable tube ø2 |
| C3 | Applicable tube ø3 |
| C4 | Applicable tube ø4 |
| N1 | Applicable tube ø1/8" |
| N3 | Applicable tube ø5/32" |

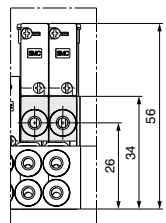
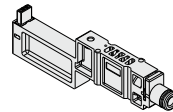

Mounted on the manifold block to make an independent exhaust port when the exhaust from one valve affects valves on other stations in the air circuit.

Weight: 15 g

Plug-in Type
Stacking Base

SUP block plate
SS0700-B-P

When different pressures, high and low, are supplied to one manifold, a SUP block plate is inserted between the stations under different pressures.

- *: Specify the number of stations on the manifold specification sheet.

<Block indication label>

When using block plates for SUP passage, indication label for confirmation of the blocking position from outside is attached. (One label of each)

- *: When ordering a block plate for SUP incorporated with the manifold, a block indication label is attached to the manifold.

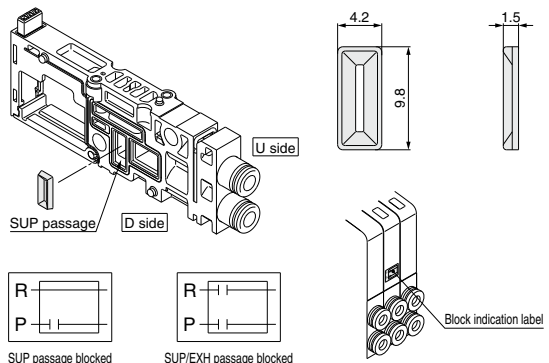

Weight: 0.3 g

S0700 Series

Plug-in Type
Stacking Base

EXH block plate

SS0700-B-R

When valve exhaust affects the other stations on the circuit, insert EXH block plate in between stations to separate valve exhaust.

*: Specify the number of stations on the manifold specification sheet.

<Block indication label>

When using block plates for EXH passage, indication label for confirmation of the blocking position from outside is attached. (One label of each)

*: When ordering a block plate for EXH incorporated with the manifold, a block indication label is attached to the manifold.

Weight: 0.3 g

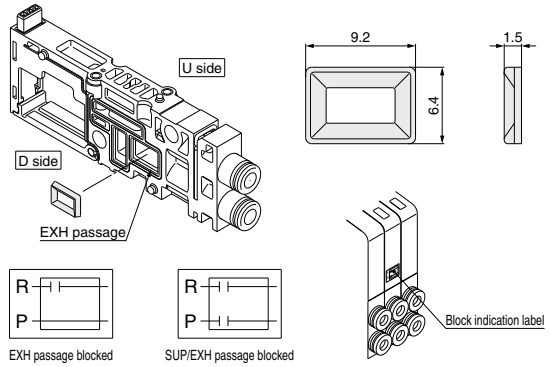

Plug-in Type
Stacking Base

Back pressure check valve [-B]

SS0700-7A-1

It prevents cylinder malfunction caused by other valve exhaust. Insert it into R (EXH) port on the manifold side of a valve which is affected. It is effective when a single action cylinder is used, etc.

*: When a check valve for back pressure prevention is desired, and is to be installed only in certain manifold stations, clearly write the part number and specify the number of stations on the manifold specification sheet.

*: When ordering this option incorporated with a manifold, suffix -B to the end of the manifold part number.

Weight: 0.1 g

⚠ Caution

1. The manifold installed type back pressure check valve assembly is assembly parts with a check valve structure. However, since slight air leakage against the back pressure is allowed due to its structure, adverse effects of the back pressure due to increase in exhaust resistance cannot be prevented if the manifold exhaust port and other exhaust ports are put together for piping or if the piping diameter is narrowed. As a result, this may cause the actuator and air operated equipment to malfunction. So, be careful not to restrict the exhaust air.
2. When a back pressure check valve is mounted, the effective area of the valve will decrease by about 20%.
3. When operating the cylinder by the external force, the cylinder is difficult to operate if the back pressure check valve is mounted.

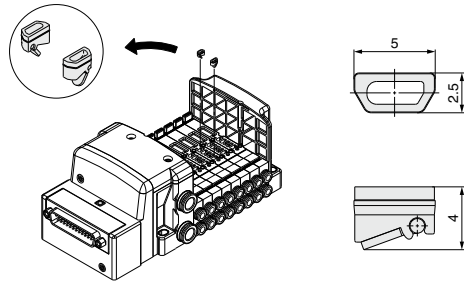

Slim Compact
Bar Base **Plug-in Type**
Stacking Base

Blanking plate with output

SS0700-1C

| Type | Lead wire length [mm] | |
|------|-----------------------|------|
| | Nil | 600 |
| 3C | 10 | 1000 |
| | 15 | 1500 |
| 1C | 20 | 2000 |
| | 25 | 2500 |
| | 30 | 3000 |

Blanking plate with a connector for individually outputting electricity to drive a single valve or equipment that are not on the manifold base.

*: Electric current should be 0.5 A or less. (Including the mounted valves) When the current is output from two positions at the same time, the current should be 0.25 A or less.

*: Please consult with SMC for the max. allowable current for serial transmission kit.

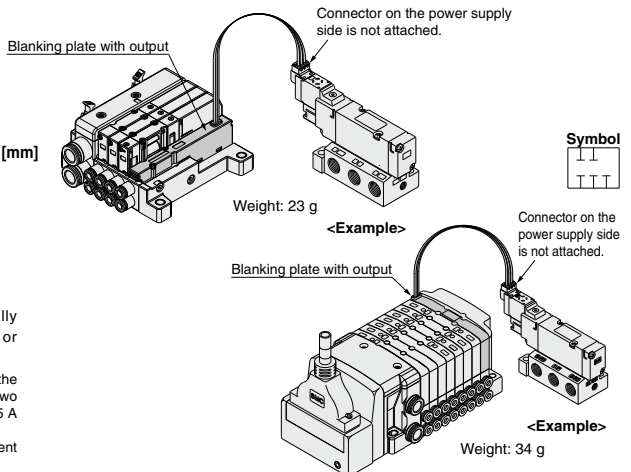

Slim Compact Bar Base

Plug-in Type Stacking Base

Port plug

VVQ000-CP

The plug is used to block the cylinder port when using a 5-port valve as a 3-port valve.

*: When ordering a plug incorporated with a manifold, indicate CM for the port size in the manifold part number, as well as, the mounting position and number of stations and cylinder port mounting positions, A and B on the manifold specification sheet.

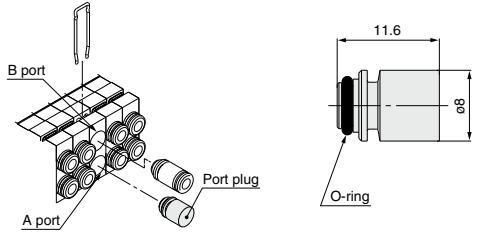

SJ

SY

SY

S0700

S0700

Slim Compact Bar Base

Plug-in Type Stacking Base

DIN rail mounting bracket

**Slim compact bar base
SS0700-57A-3**

**Plug-in type stacking base
SS0700-57A-□**



| Symbol | Specifications |
|--------|---------------------------------------|
| Nil | S (EX260/EX500/EX600), F, P, L, M kit |
| S | S (EX250) kit |
| T | T kit |

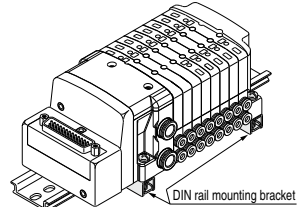
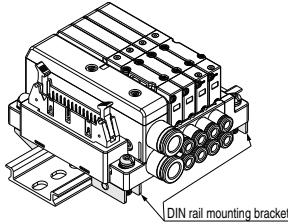

It is used for mounting a manifold on a DIN rail. The DIN rail mounted bracket is fixed to the manifold end plate. (The specification is the same as that for the option -D.) 1 set of DIN rail mounting bracket is included for 1 manifold (2 or 3 DIN rail mounting brackets (S, T kit)).

*: When ordering this option incorporated with a manifold, suffix D to the end of the manifold part number.

Slim Compact Bar Base

Plug-in Type Stacking Base

Applicable to DIN rail mounting

Each manifold can be mounted on a DIN rail. Order it by indicating a manifold mounting symbol for DIN rail mounting [-D]. Standard DIN rail which is approx. 30 mm longer than the manifold with the specified number of stations is attached. The following options are also available.

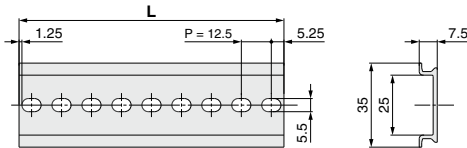

●DIN rail length longer than the standard (for stations to be added later, etc.)

In the manifold part number, specify -D for the manifold mounting symbol and add the number of required stations after the symbol.

Example) **SS0750-08C4FD0-D09K**



●How to Order DIN rail only

DIN rail part number
AXT100-DR-n

*: For n, enter a number from the No. line in the table below. For L dimension, refer to the dimensions of each kit.

L Dimension

| No. | 1 | 2 | 3 | 4 | 5 | 6 | 7 | 8 | 9 | 10 |
|-------------|-----|-------|-----|-------|-----|-------|-----|-------|-----|-------|
| L dimension | 23 | 35.5 | 48 | 60.5 | 73 | 85.5 | 98 | 110.5 | 123 | 135.5 |
| No. | 11 | 12 | 13 | 14 | 15 | 16 | 17 | 18 | 19 | 20 |
| L dimension | 148 | 160.5 | 173 | 185.5 | 198 | 210.5 | 223 | 235.5 | 248 | 260.5 |
| No. | 21 | 22 | 23 | 24 | 25 | 26 | 27 | 28 | 29 | 30 |
| L dimension | 273 | 285.5 | 298 | 310.5 | 323 | 335.5 | 348 | 360.5 | 373 | 385.5 |
| No. | 31 | 32 | 33 | 34 | 35 | 36 | 37 | 38 | 39 | 40 |
| L dimension | 398 | 410.5 | 423 | 435.5 | 448 | 460.5 | 473 | 485.5 | 498 | 510.5 |

L = 12.5 x n + 10.5

S0700 Series

Slim Compact
Bar Base

Plug-in Type
Stacking Base

Blanking plug (For One-touch fittings)

KJP-02

KQ2P-04
23
06

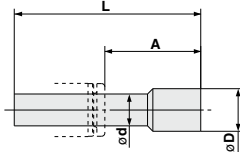
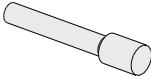

Dimensions

| Applicable fitting size ϕd | Model | A | L | D | Weight: g |
|----------------------------------|----------------|-----|------|-----|-----------|
| 2 | KJP-02 | 8.2 | 17 | 3 | 0.1 |
| 3.2 | KQ2P-23 | 16 | 31.5 | 3.2 | 1 |
| 4 | KQ2P-04 | 16 | 32 | 6 | 1 |
| 6 | KQ2P-06 | 18 | 35 | 8 | 1 |

It is inserted into an unused cylinder port and SUP/EXH ports.

Purchasing order is available in units of 10 pieces.

Slim Compact
Bar Base

Plug-in Type
Stacking Base

Silencer (For EXH port)

This silencer is to be inserted into the EXH port (One-touch fitting) of the common exhaust type.

AN15-C08

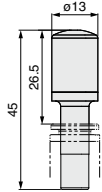
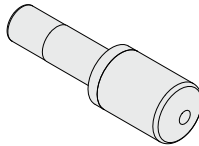

Specifications

| Model | Effective area [mm ²] (Cv factor) | Noise reduction [dB] |
|----------|--|----------------------|
| AN15-C08 | 20 (1.1) | 30 |

Plug-in Type
Stacking Base

Name plate [-N]

SS0700-N-Station (1 to max. stations)

It is a transparent resin plate for placing a label that indicates solenoid valve function, etc.

Insert it into the groove on the side of the end plate and bend it as shown in the figure.

*: When ordering this option incorporated with a manifold, suffix -N to the end of the manifold part number.

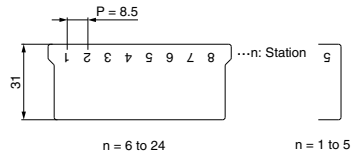
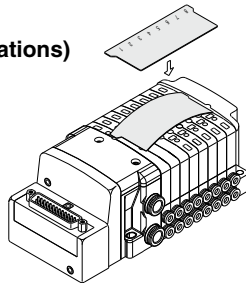

Plug-in Type
Stacking Base

Dual flow fitting
SS0700-52A-C6

Port size
C6 ø6

To drive a large bore cylinder, two valve stations are operated simultaneously to double the air flow. This fitting is used on the cylinder ports in this situation. Available sizes are ø6 One-touch fittings.

- *: A dedicated clip necessary to mount the dual flow fitting on the manifold is attached.
- *: When ordering the dual flow fitting mounted on the manifold, please specify CM (NM) for the port size of the manifold part number and the station positions on the manifold specification sheet.

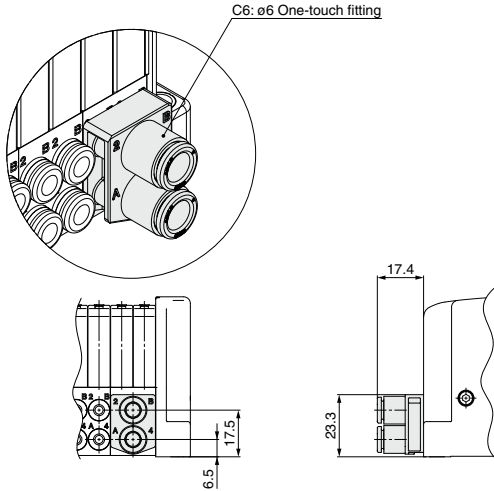

SJ
SY
SY
S0700
S0700

Plug-in Type
Stacking Base

SUP/EXH block
SS0700-PR-1-C6

P, R port size

(When the port size is a different diameter, the P port size is shown.)

| | |
|-----------|---|
| C0 | Without One-touch fitting (With a clip) |
| C6 | With ø6 One-touch fitting |
| C8 | With ø8 One-touch fitting |
| N7 | With ø1/4" One-touch fitting |
| N9 | With ø5/16" One-touch fitting |

Option

| | |
|------------|---|
| Nil | Internal pilot, Common exhaust (Standard) |
| R | External pilot |
| S | Direct exhaust (Built-in silencer) |
| RS | External pilot + Direct exhaust |

R port size

(P and R port sizes are different diameters.)

| | |
|------------|---------------------------------------|
| Nil | Same diameter and built-in silencer S |
| C6 | With ø6 One-touch fitting |
| C8 | With ø8 One-touch fitting |
| N7 | With ø1/4" One-touch fitting |
| N9 | With ø5/16" One-touch fitting |

It is added to the manifold to increase SUP/EXH capacity.

- *: SUP/EXH blocks are not included in the number of manifold stations.
- *: Specify the mounting position on the manifold specification sheet.

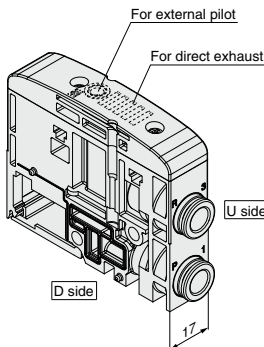

| | | Stations | | | |
|-------------------|------------------|----------|---|---|---|
| Description/Model | | 1 | 2 | 3 | 4 |
| Valve | Single | ● | ● | ● | |
| | ⋮ | | | | |
| Option | SUP/EXH block | | | | ● |
| | SS0700-PR-1-C6-□ | | | | |

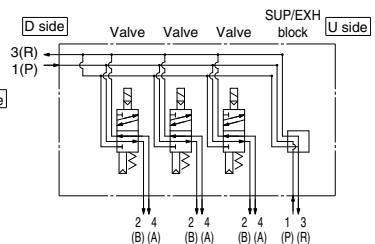



S0700 Series

Specific Product Precautions 1

Be sure to read this before handling the products.

Refer to back page 50 for Safety Instructions and pages 3 to 9 for 3/4/5 Port Solenoid Valve Precautions.

Manual Override

Warning

The manual override is used for switching the main valve.

Push type (Tool required)

Push down on the manual override button with a small screwdriver until it stops.

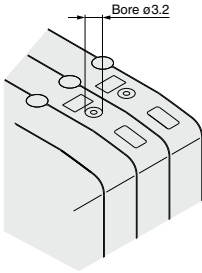

How to Mount Valve

Caution

Tighten the bolts firmly to stop the gasket from coming away from the valve using the appropriate torque as shown on the following table.

Proper tightening torque [N·m]

0.17 to 0.23

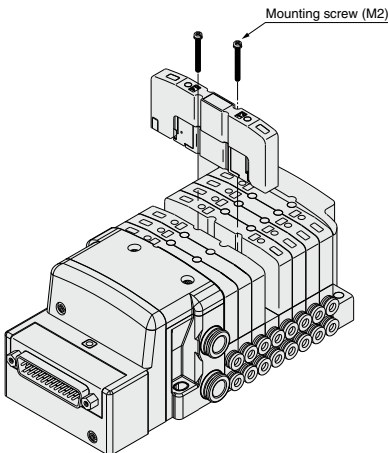

How to Mount/Remove DIN Rail

Caution

Removal

- 1) Loosen the clamping screw of the end plate on both sides.
- 2) Lift side (a) of the manifold base and slide the end plate in the direction of ② shown in the figure to remove.

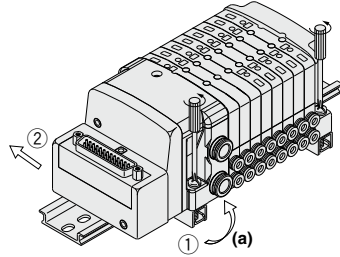

Mounting

- 1) Hook side (b) of the manifold base on the DIN rail.
- 2) Press down side (a) and mount the end plate on the DIN rail. Tighten the clamping screw on side (a) of the end plate. The proper tightening torque for screws is 0.4 to 0.6 N·m.

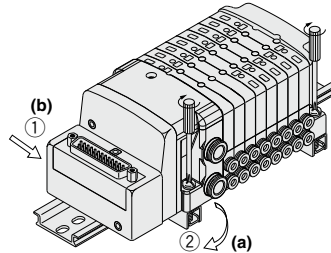

How to Change Connector Entry Direction

Caution

<Plug-in manifold stacking base>

The connector entry direction can be changed from the top to the side by simply pressing the manual release button.

It is not necessary to use the manual release button when switching from the side to the top.

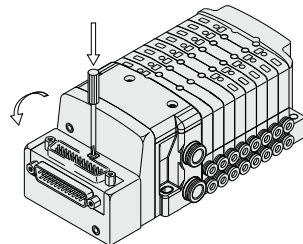

SJ

SY

SY

S0700

S0700



S0700 Series Specific Product Precautions 2

Be sure to read this before handling the products.
Refer to back page 50 for Safety Instructions and pages 3 to 9 for 3/4/5 Port Solenoid Valve Precautions.

Built-in Silencer Element

⚠ Caution

<Plug-in type only>

A silencer element is incorporated in the end plate on both sides of the base. A dirty and choked element may reduce cylinder speed or cause a malfunction. Clean or replace the dirty element.

Element Part No.

| Type | Element part no. |
|--|------------------|
| Slim compact plug-in manifold bar base SS0751 | SS0700-83A |
| Plug-in manifold stacking base SS0750 | SS0700-82A |

*: Above part number is for a set of ten elements.

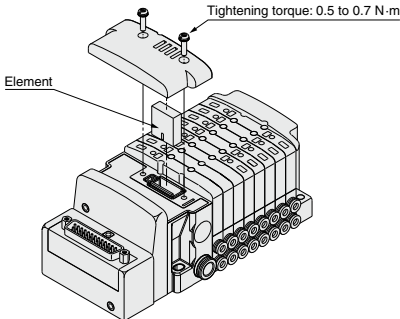

Remove the cover from the side of the end plate and remove the old element with a flat blade screwdriver, etc.

How to Replace Cylinder Port Fittings

⚠ Warning

The cylinder port fittings are a cassette for easy replacement. The fittings are blocked by a clip inserted from the top of the valve.

Remove the clip with a flat blade screwdriver to remove fittings. For replacement, insert the fitting assembly until it strikes against the inside wall and then re-insert the clip to the specified position.

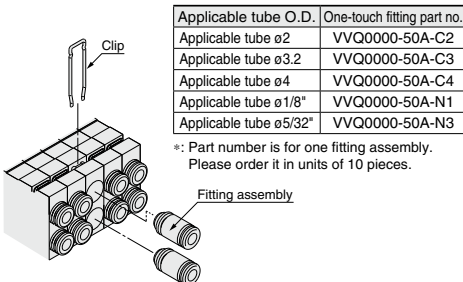

Internal Wiring Specifications

⚠ Caution

Light/surge voltage suppressor

No polarity by adopting non-polar light.

Single

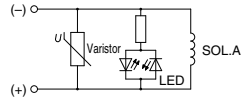

Double, Dual 3-port

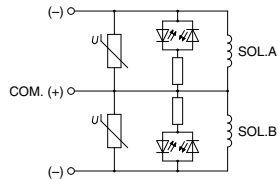

*: Coil surge voltage generated when OFF is about -60 V. Please contact SMC separately for further suppression of the coil surge voltage.

Slim type plug-in manifold

A: Red
B: Green

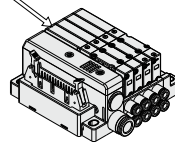

Plug-in manifold

Indicator light
A side

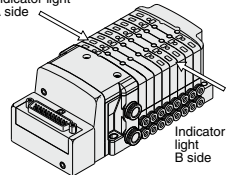

Surge Voltage Intrusion

⚠ Caution

The surge voltage created when the power supply is cut off could apply to the de-energized load equipment through the output circuit. In cases where the energized load equipment has a larger capacity (power consumption) and is connected to the same power supply as the product, the surge voltage could malfunction and/or damage the internal circuit element of the product and the internal device of the output equipment. To avoid this situation, place a diode which can suppress the surge voltage between the COM lines of the load equipment and output equipment.



S0700 Series

Specific Product Precautions 3

Be sure to read this before handling the products.

Refer to back page 50 for Safety Instructions and pages 3 to 9 for 3/4/5 Port Solenoid Valve Precautions.

Serial EX500/EX250/EX260 Precautions

Warning

1. These products are intended for use in general factory automation equipment.
Avoid using these products in machinery/equipment which affects human safety, and in cases where malfunction or failure can result in extensive damage.
2. Do not use in an explosive atmosphere, environment with inflammable gases, or corrosive atmosphere. This can cause injury or fire, etc.
3. Work such as transporting, installing, piping, wiring, operation, control and maintenance should be performed by personnel with specialized knowledge. There is a danger of electrocution, injury or fire, etc.
4. Install an external emergency stop circuit that can promptly stop operation and shut off the power supply.
5. Do not remodel these products, as there is a danger of injury and damage.

Caution

1. Read the operation manual carefully, strictly observe the precautions and operate within the range of the specifications.
2. Do not drop these products or submit them to strong impacts. This can cause damage, failure or malfunction, etc.
3. In locations with poor electrical conditions, take steps to ensure a steady flow of the rated power supply. Use of a voltage outside of the specifications can cause malfunction, damage to the unit, electrocution or fire, etc.
4. Do not touch connector terminals or internal substrates when current is being supplied. There is a danger of malfunction, damage to the unit or electrocution if connector terminals or internal substrates are touched when current is being supplied.
Be sure that the power supply is OFF when adding or removing manifold valves or input blocks, etc., or when connecting or disconnecting connectors.
5. Operate at an ambient temperature that is within the specifications. Even when the ambient temperature range is within the specifications, do not use in locations where there are rapid temperature changes.
6. Keep wire scraps and other extraneous material from getting inside these products. This can cause fire, failure or malfunction, etc.
7. This product is not constructed to withstand water or oil penetration. Therefore it should be fitted with a protective cover when used in environments where it could be exposed to water or oil splash.
8. Observe the proper tightening torque.
There is a possibility of damaging threads if tightening exceeds the tightening torque range.
9. Adjustment/Operation
DIP switches and rotary switches should be set with a small watchmakers' screwdriver.

Caution

10. Provide adequate protection when operating in locations such as the following:
 - Where noise is generated by static electricity, etc.
 - Where there is a strong electric field
 - Where there is a danger of exposure to radiation
 - When in close proximity to power supply lines
11. When these products are installed in equipment, provide adequate protection against noise by using noise filters, etc.
12. Since these products are components that are used after installation in other equipment, the customer should confirm conformity to EMC directives for the finished product.
13. Do not remove the name plate.
14. Perform periodic inspections and confirm normal operation. It may otherwise be impossible to guarantee safety due to unexpected malfunction or erroneous operation.
15. For the EX260-SPN□, the side of the SI unit may become hot.
It may cause burns.
16. Do not use this product in places where there are cyclic temperature changes.
In case that the cyclic temperature is beyond normal temperature changes, the inside product is likely to be adversely affected.
17. Do not use in direct sunlight.
Do not use in direct sunlight. It may cause a malfunction or damage.
18. Do not use in places where there is radiated heat around it.
Such a place is likely to cause a malfunction.

Safety Instructions on Power Supply

Caution

1. Operation is possible with a single power supply or a separate power supply. However, be sure to provide two wiring systems (one for solenoid valves, and one for input and control units).
2. When applicable to UL, use a Class 2 power supply unit conforming to UL1310 for direct current power supply.

SJ

SY

SY

S0700

S0700



S0700 Series

Specific Product Precautions 4

Be sure to read this before handling the products.

Refer to back page 50 for Safety Instructions and pages 3 to 9 for 3/4/5 Port Solenoid Valve Precautions.

Serial EX500/EX250/EX260 Precautions

Safety Instructions on Cable

⚠ Caution

1. Be careful of miswiring. This can cause malfunction, damage and fire in the unit.
2. Do not connect cables during energizing.
This could damage or cause malfunction to the SI unit.
3. To prevent noise and surge in signal lines, keep all wiring separate from power lines and high voltage lines. Otherwise, this can cause malfunction.
4. Check wiring insulation, as defective insulation can cause damage to the unit due to excessive voltage or current.
5. Do not bend or pull cables repeatedly, and do not place heavy objects on them or allow them to be pinched. This can cause broken lines.

Serial EX510 Precautions

Design/Selection

⚠ Warning

1. Use within the allowable voltage range.
Using beyond the allowable voltage range is likely to cause the units and connecting devices to be damaged or to malfunction.
2. Do not use beyond the specification range.
Using beyond the specification range is likely to cause a fire, malfunction, or breakdown in the units and connecting devices. Check the specifications before handling.
3. Establish a backup system beforehand, which employs fail-safe concepts such as multiple equipment and devices to prevent breakage or malfunction of this product.
4. Provide an external emergency stop circuit that will immediately stop an operation and cut off the power supply.
5. When using for an interlock circuit:
 - Provide a double interlock which is operated by another system (such mechanical protection function).
 - Perform an inspection to check that it is working properly because it can cause possible injuries.

⚠ Caution

1. Keep the surrounding space free for maintenance.
When designing a system, take into consideration the amount of free space needed for performing maintenance.
2. When applicable to UL, use a Class 2 power supply unit conforming to UL1310 for direct current power supply.
3. This product is one of the components to be equipped into a final equipment. Confirm the adaptability to the EMC directive as the whole equipment by customers themselves.
4. The power supply for the Gateway unit should be 0 V as the standard for both power supply for outputs as well as inputs and for the control unit of the Gateway.

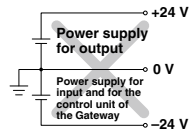
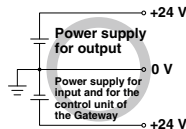

Mounting

⚠ Caution

1. Do not drop, bump, or apply excessive impact.
Otherwise, the unit can become damaged, malfunction, or fail to function.
2. Hold the body while handling this product.
Otherwise, the unit can become damaged, malfunction, or fail to function.
3. Observe the tightening torque range.
Tightening outside of the allowable torque range will likely damage the product.
4. Do not install a unit in a place where it can be used as a scaffold.
Applying any excessive load such as stepping on the unit by mistake or placing a foot on it, will cause it to break.



S0700 Series

Specific Product Precautions 5

Be sure to read this before handling the products.

Refer to back page 50 for Safety Instructions and pages 3 to 9 for 3/4/5 Port Solenoid Valve Precautions.

Serial EX510 Precautions

Wiring

Warning

- 1. Avoid miswiring.**
If miswired, there is a probability of damaging units or connecting devices.
- 2. Do not wire while energizing the product.**
It is likely to damage the units or connecting devices.
- 3. Avoid wiring the power line and high pressure line in parallel.**
Noise or surge produced by signal line resulting from the power line or high pressure line could cause a malfunction. Wiring of the reduced wiring system and the power line or high pressure line should be separated from each other.
- 4. Check the wiring insulation.**
Inferior insulation (contact with other circuit, insulation between terminals, etc.) will likely cause damage to the units or connecting devices due to excessive voltage or the influx of current.

Caution

- 1. Take measures to avoid applying repeated bending force or pulling force to the cable.**
Also, pay attention not to place any heavy matter on the cable or clipping. It is likely to cause a broken wire.
- 2. Check the grounding to maintain the safety of the reduced wiring system and for anti-noise performance.**
Grounding should be close to units and keep the grounding distance short.

Operating Environment

Warning

- 1. Do not use this product in the presence of dust, particles, water, chemicals, and oil.**
Use with such materials is likely to cause a malfunction or breakage.
- 2. Do not use this product in the presence of a magnetic field.**
Use in such an environment is likely to cause a malfunction.
- 3. Do not use this product in an atmosphere containing an inflammable gas, explosive gas, or corrosive gas.**
Use in such an atmosphere is likely to cause a fire, explosion, or corrosion. This wire-reduced system is not explosion-proof.
- 4. Do not use this product in places where there are cyclic temperature changes.**
In case that the cyclic temperature is beyond normal temperature changes, the internal unit is likely to be adversely affected.
- 5. Do not use this product in places where there is radiated heat around it.**
Such a place is likely to cause a malfunction or breakage.
- 6. Do not use this product near sources that generate a surge which exceeds the benchmark test, even though this product is CE/UKCA-marked certified.**
The internal circuit components are likely to deteriorate or become damaged when there are equipment (solenoid type lifter, high frequency guided furnace, motor, etc.) which generate a large surge around the reduced wiring system. Take measures to prevent an electrical surge and avoid having the wires touch each other.

Operating Environment

Warning

- 7. Use the product type that has an integrated surge absorption element when directly driving a load which generates surge voltage by relay or solenoid valves.**
- 8. The reduced wiring system should be installed in places with no vibration or shock.**
Such a place is likely to cause a malfunction or breakage.
- 9. Do not use in direct sunlight.**
Do not use in direct sunlight. It may cause a malfunction or damage.
- 10. Use this product within the specified ambient temperature range.**
This may cause a malfunction.

Adjustment/Operation

Warning

- 1. Do not short-circuit a load.**
If a load is short-circuited, excessive current can cause damage to the connected devices. The fuse of the input unit will melt. The output and SI unit will activate its overcurrent protection function. However, they cannot cover all modes, so damage is likely to occur.
- 2. Do not manipulate or perform settings with wet hands.**
Performing such activity will likely cause an electrical shock.

Caution

- 1. DIP switches and rotary switches should be set with a small watchmakers' screwdriver.**

Maintenance

Warning

- 1. Do not disassemble, modify (including circuit board replacement) or repair this product.**
Such actions are likely to cause injuries or breakage.
- 2. Perform periodic inspection.**
Confirm that wiring or screws are not loose. Otherwise, unpredicted malfunction in the system composition devices is likely to occur.
- 3. When an inspection is performed.**
 - Turn off the power supply.
 - Stop the supplied fluid and discharge the fluid in the piping and confirm the release to the atmosphere before performing an inspection. It is likely to cause injuries.

Caution

- 1. Do not wipe this product with chemicals such as benzine or thinner.**
Using such chemicals is likely to cause damage.

SJ

SY

SY

S0700

S0700



S0700 Series

Specific Product Precautions 6

Be sure to read this before handling the products.

Refer to back page 50 for Safety Instructions and pages 3 to 9 for 3/4/5 Port Solenoid Valve Precautions.

Serial EX600 Precautions

Design/Selection

⚠ Warning

- 1. Use this product within the specification range.**
Using beyond the specified specifications range can cause fire, malfunction, or damage to the system.
Check the specifications when operating.
- 2. When using for an interlock circuit:**
 - Provide a multiple interlock system which is operated by another system (such as mechanical protection function).
 - Perform an inspection to confirm that it is working properly.
This may cause possible injury due to malfunction.

⚠ Caution

- 1. When applicable to UL, use a Class 2 power supply unit conforming to UL1310 for direct current power supply.**
- 2. Use this product within the specified voltage range.**
Using beyond the specified voltage range is likely to cause the units and connecting devices to be damaged or to malfunction.
- 3. The power supply for the unit should be 0 V as the standard for both power supply for output as well as power supply for control/input.**

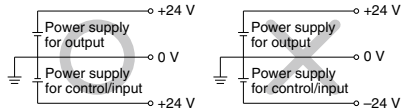

- 4. Do not install a unit in a place where it can be used as a foothold.**
Applying any excessive load such as stepping on the unit by mistake or placing a foot on it, will cause it to break.
- 5. Keep the surrounding space free for maintenance.**
When designing a system, take into consideration the amount of free space needed for performing maintenance.
- 6. Do not remove the name plate.**
Improper maintenance or incorrect use of operation manual can cause failure and malfunction. Also, there is a risk of losing conformity with safety standards.
- 7. Beware of inrush current when the power supply is turned on.**
Some connected loads can apply an initial charge current which will trigger the over current protection function, causing the unit to malfunction.

Mounting

⚠ Caution

- 1. When handling and assembling units:**
 - Do not touch the sharp metal parts of the connector or plug.
 - Do not apply excessive force to the unit when disassembling.
The connecting portions of the unit are firmly joined with seals.
 - When joining units, take care not to get fingers caught between units.
Injury can result.

Mounting

⚠ Caution

- 2. Do not drop, bump, or apply excessive impact.**
Otherwise, the unit can become damaged, malfunction, or fail to function.
- 3. Observe the tightening torque range.**
Tightening outside of the allowable torque range will likely damage the product.
IP67 protection class cannot be guaranteed if the screws are not tightened to the specified torque.
- 4. When lifting a large size manifold solenoid valve unit, take care to avoid causing stress to the valve connection joint.**
The connection parts of the unit may be damaged.
Because the unit may be heavy, carrying and installation should be performed by more than one operator to avoid strain or injury.
- 5. When placing a manifold, mount it on a flat surface.**
Torsion in the whole manifold can lead to trouble such as air leakage or defective insulation.

Wiring

⚠ Caution

- 1. Check the grounding to maintain the safety of the reduced wiring system and for anti-noise performance.**
Provide a specific grounding as close to the unit as possible to minimize the distance to grounding.
- 2. Avoid repeatedly bending or stretching the cable and applying a heavy object or force to it.**
Wiring applying repeated bending and tensile stress to the cable can break the circuit.
- 3. Avoid miswiring.**
If miswired, there is a danger of malfunction or damage to the reduced wiring system.
- 4. Do not wire while energizing the product.**
There is a danger of malfunction or damage to the reduced wiring system or input/output equipment.
- 5. Avoid wiring the power line and high pressure line in parallel.**
Noise or surge produced by signal line resulting from the power line or high pressure line could cause malfunction.
Wiring of the reduced wiring system or input/output device and the power line or high pressure line should be separated from each other.
- 6. Check the wiring insulation.**
Defective insulation (contact with other circuits, improper insulation between terminals, etc.) may cause damage to the reduced wiring system or input/output device due to excessive voltage or current.



S0700 Series

Specific Product Precautions 7

Be sure to read this before handling the products.

Refer to back page 50 for Safety Instructions and pages 3 to 9 for 3/4/5 Port Solenoid Valve Precautions.

Serial EX600 Precautions

Wiring

Caution

- When a reduced wiring system is installed in machinery/equipment, provide adequate protection against noise by using noise filters, etc.
Noise in signal lines may cause a malfunction.
- When connecting wires of input/output device or handheld terminal, prevent water, solvent or oil from entering inside from the connector section.
This can cause damage, equipment failure or malfunction.
- Avoid wiring patterns in which excessive stress is applied to the connector.
This may cause malfunction or damage to the unit due to contact failure.

Operating Environment

Warning

- Do not use in an atmosphere containing an inflammable gas or explosive gas.
Use in such an atmosphere is likely to cause a fire or explosion. This system is not explosion-proof.

Caution

- Select the proper type of enclosure according to the environment of operation.
IP65/67 is achieved when the following conditions are met.
 - Provide appropriate wiring between units using electrical wiring cables, communication connectors and cables with M12 connectors.
 - Suitable mounting of each unit and manifold valve.
 - Be sure to mount a seal cap on any unused connectors.
 If using in an environment that is exposed to water splashes, please take measures such as using a cover.
When the enclosure is IP40, do not use in an operating environment or atmosphere where it may come in contact with corrosive gas, chemical agents, seawater, water, or water vapor.
When connected to the EX600-D□□E or EX600-D□□F, manifold enclosure is IP40.
Also, the Handheld Terminal conforms to IP20, so prevent foreign matter from entering inside, and water, solvent or oil from coming in direct contact with it.
- Provide adequate protection when operating in locations such as the following.
Failure to do so may cause damage or malfunction. The effect of countermeasures should be checked in individual equipment and machine.
 - Where noise is generated by static electricity, etc.
 - Where there is a strong electric field
 - Where there is a danger of exposure to radiation
 - When in close proximity to power supply lines

Operating Environment

Caution

- Do not use in an environment where oil and chemicals are used.
Operating in environments with coolants, cleaning solvents, various oils or chemicals may cause adverse effects (damage, malfunction) to the unit even in a short period of time.
- Do not use in an environment where the product could be exposed to corrosive gas or liquid.
This may damage the unit and cause it to malfunction.
- Do not use in locations with sources of surge generation.
Installation of the unit in an area around the equipment (electromagnetic lifters, high frequency induction furnaces, welding machine, motors etc.) which generates the large surge voltage could cause to deteriorate an internal circuitry element of the unit or result in damage. Implement countermeasures against the surge from the generating source, and avoid touching the lines with each other.
- Use the product type that has an integrated surge absorption element when directly driving a load which generates surge voltage by relay, solenoid valves or lamp.
When a surge generating load is directly driven, the unit may be damaged.
- The product is CE/UKCA marked, but not immune to lightning strikes. Take measures against lightning strikes in your system.
- Keep dust, wire scraps and other extraneous material from getting inside the product.
This may cause a malfunction or damage.
- Mount the unit in such locations, where no vibration or shock is affected.
This may cause a malfunction or damage.
- Do not use in places where there are cyclic temperature changes.
In case that the cyclic temperature is beyond normal temperature changes, the internal unit is likely to be adversely effected.
- Do not use in direct sunlight.
Do not use in direct sunlight. It may cause a malfunction or damage.
- Use this product within the specified ambient temperature range.
This may cause a malfunction.
- Do not use in places where there is radiated heat around it.
Such a place is likely to cause a malfunction.

SJ

SY

SY

S0700

S0700



S0700 Series

Specific Product Precautions 8

Be sure to read this before handling the products.

Refer to back page 50 for Safety Instructions and pages 3 to 9 for 3/4/5 Port Solenoid Valve Precautions.

Serial EX600 Precautions

Adjustment/Operation

Maintenance

⚠ Warning

1. **Do not perform operation or setting with wet hands.**

There is a risk of electrical shock.

<Handheld Terminal>

2. **Do not apply pressure to the LCD.**

There is a possibility of the crack of LCD and injuring.

3. **The forced input/output function is used to change the signal status forcibly. When operating this function, be sure to check the safety of the surroundings and installation.**

Otherwise, injury or equipment damage could result.

4. **Incorrect setting of parameters can cause malfunction. Be sure to check the settings before use.**

This may cause injury or equipment damage.

⚠ Caution

1. **Use a watchmakers' screwdriver with thin blade for the setting of each switch of the SI unit. When setting the switch, do not touch other unrelated parts.**

This may cause parts damage or malfunction due to a short-circuit.

2. **Provide adequate setting for the operating conditions.**

Failure to do so could result in malfunction.

Refer to the operation manual for setting of the switches.

3. **For details on programming and address setting, refer to the manual from the PLC manufacturer.**

The content of programming related to protocol is designed by the manufacturer of the PLC used.

<Handheld Terminal>

4. **Do not press the setting buttons with a sharp pointed object.**

This may cause damage or malfunction.

5. **Do not apply excessive load and impact to the setting buttons.**

This may cause damage, equipment failure or malfunction.

⚠ Warning

1. **Do not disassemble, modify (including circuit board replacement) or repair this product.**

Such actions are likely to cause injuries or breakage.

2. **When an inspection is performed,**

- **Turn off the power supply.**
- **Stop the air supply, exhaust the residual pressure in piping and verify that the air is released before performing maintenance work.**

Unexpected malfunction of system components and injury can result.

⚠ Caution

1. **When handling and replacing the unit:**

- **Do not touch the sharp metal parts of the connector or plug.**
- **Do not apply excessive force to the unit when disassembling.**

The connecting portions of the unit are firmly joined with seals.

- **When joining units, take care not to get fingers caught between units.**

Injury can result.

2. **Perform periodic inspection.**

Unexpected malfunction in the system composition devices is likely to occur due to malfunction of machinery or equipment.

3. **After maintenance, make sure to perform an appropriate functionality inspection.**

In cases of abnormality such as faulty operation, stop operation. Unexpected malfunction in the system composition devices is likely to occur.

4. **Do not use benzene and thinner for cleaning units.**

Damage to the surface or erasure of the display can result. Wipe off any stains with a soft cloth.

If the stain is persistent, wipe off with a cloth soaked in a dilute solution of neutral detergent and wrung out tightly, and then finish with a dry cloth.

When the order does not include the SI unit, the valve plate to connect the manifold and SI unit is not mounted. Use attached valve fixing screws and mount the valve plate.
(Tightening torque: 0.6 to 0.7 N·m)

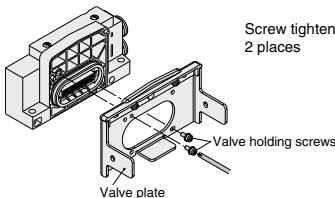

■ Trademark

DeviceNet® is a registered trademark of ODVA, Inc.

EtherNet/IP® is a registered trademark of ODVA, Inc.

EtherCAT® is registered trademark and patented technology, licensed by Beckhoff Automation GmbH, Germany.

S0700 Series Troubleshooting

| Trouble | In the event of product failure, take remedial measures by checking the following items as detailed below. | Cause | Measures |
|--|--|---|---|
| Operating failure The air supply direction has not been changed. | <pre> graph TD Q1{Does the product operate by pressing a manual button?} -- NO --> C1 Q1 -- YES --> C2 Q2{Does the indicator light illuminate when energizing?} -- NO --> C3 Q2 -- YES --> C4 Q2 -- YES --> C5 </pre> | 1) Slide failure or sticking of the main valve Foreign matter from the air source has been caught in the main valve and has caused slide failure and sticking. | <ul style="list-style-type: none"> Replace the valve. Purify the air source. (Refer to the 3/4/5 Port Solenoid Valves Precautions 6 on page 8.) |
| | | 2) Pressure drop The pressure of the air source decreases and fails to reach the minimum operating pressure of the valve, resulting in operating failure. | Adjust the pressure of the valve within the operating pressure range. |
| | | 1) Electric system error <ul style="list-style-type: none"> Sequencer failure Incorrect wiring Open fuse and lead wire disconnection Voltage drop | Check each item and take applicable measure. |
| | | 1) Voltage drop The product may not operate due to a voltage drop even when its indicator light remains illuminated. | Check the voltage and take applicable measure if decreased. |
| | | 2) Current leakage The product does not shift from off to on due to the residual voltage. | Check the residual voltage, which shall be 2% or less of rated voltage. |
| | | 3) Pilot valve failure <ul style="list-style-type: none"> Foreign matter from the air source has entered the inside of the pilot valve and has caused operating failure. Open coil circuit | <ul style="list-style-type: none"> Replace the valve. Purify the air source. (Refer to the 3/4/5 Port Solenoid Valves Precautions 6 on page 8.) |
| Response failure The product operates, but has a time delay. | | 1) Current leakage The response of the product was delayed due to the residual voltage. | Check the residual voltage, which should be 2% or less of the rated voltage. |
| | | 2) Clogging of the filter element of the manifold | <ul style="list-style-type: none"> Clean or replace the element. |
| | | 3) Foreign matter from the air source has entered the main valve and has caused slide failure and sticking. | <ul style="list-style-type: none"> Replace the valve. Purify the air source. (Refer to the 3/4/5 Port Solenoid Valves Precautions 6 on page 8.) |

SJ

SY

SY

S0700

S0700

S0700 Series

| Trouble | In the event of product failure, take remedial measures by checking the following items as detailed below. | Cause | Measures |
|-------------|---|--|--|
| Air leakage | <div style="border: 1px solid black; padding: 5px; display: inline-block;">Check the part where the air is leaking.</div> 1. Leakage between the valve and base → | 1-1) The clamping screw or mounting bolt is loose. | Tighten the clamping screw. Proper tightening torque 0.17 to 0.23 N·m Replace the gasket if it was damaged. |
| | | 1-2) The gasket got caught. | Replace the gasket. <Part no. of gasket and spare parts> S0700-GS-5 (10 sets) Plug-in Type Stacking Base S0700-GS-3 (10 sets) Slim Compact Bar Base |
| | 2. Air leakage from the One-touch fitting → | 2-1) The tube did not bottom out. 2-2) The tube had a flaw. 2-3) The tube end was cut uneven. |) Check each item and take applicable measures. |
| | | 2-4) The packing of the One-touch fitting was damaged. | |
| | 3. Leakage from R port → | 3-1) The mounting screw is loose. | Tighten the mounting bolt. Proper tightening torque • 0.17 to 0.23 N·m Replace the gasket if it was damaged. |
| | | 3-2) Foreign matter from the air source got caught in the main valve and increased the internal leakage. | • Replace the valve. Purify the air source. (Refer to the 3/4/5 Port Solenoid Valves Precautions 6 on page 8.) |