



e-Actuator

New



Easy to Operate

Integrated Controller

RoHS

Battery-less Absolute (Step Motor 24 VDC)

Easy to set up, just like air equipment!

2-position stop

Single/Double solenoid mode

Mode switching

3-position stop

Closed center mode

Cycle time setting available

Downsized with Integrated Controller

Wiring saving

Labor saving

· Programless · Reduced adjustment time

With internal battery-less absolute encoder

- Restart from the last stop position is possible after recovery of the power supply.
- Reduced maintenance (No need to manage or replace batteries)



Annual CO₂ emissions: **Max. 60% reduction** (SMC comparison)

p. 4

5.8 ← 14.1 [kg-CO₂e/year]

* The numerical values vary depending on the operating conditions.

Compatible Actuators

Slider Type
Size: 25, 32

Rod Type
Size: 25, 32



EQFS□H Series



EQY□H Series

EQFS□H/EQY□H Series

Simple setting allows for immediate use.

Two position stop with no programming required

For single solenoid (2-position)/ double solenoid (2-position) mode

All configurable on one screen.

Just **2 steps** to complete!

* When used in single solenoid mode, the operating mode must be changed.



Step 1 Select the operating mode.

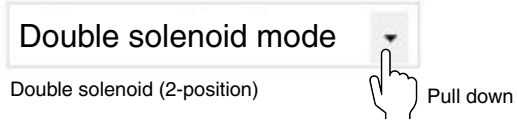

Step 2 Set the speed, acceleration, and deceleration.

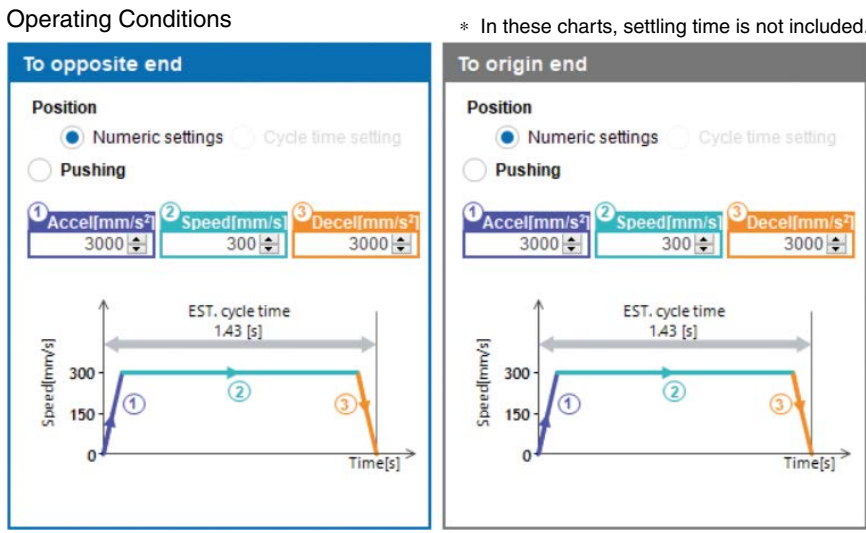

Setting complete Test operation is possible immediately after setting up.

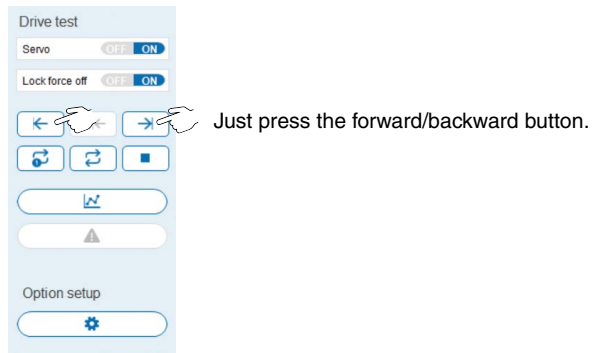

⚠ Caution

The stop position can be changed. For use in positions other than the default setting, refer to the operation manual.

Operation manual

Easy to set intermediate positions

Three position stop with no programming required For closed center (3-position) mode

All configurable on one screen.
 Just **3 steps** to complete!

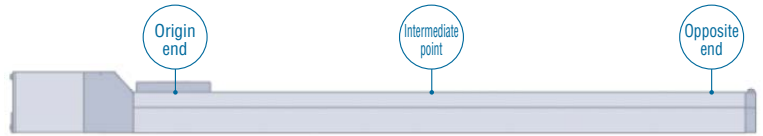

Step 1 Select the operating mode.

Closed center mode

3-position (Closed center)



Step 2 Set the intermediate point position.

Position Setup



Jog Inching

Position **0.00 mm** < >

Move speed 300mm/s

Step 3 Set the speed, acceleration, and deceleration.

Operating Conditions

* In these charts, settling time is not included.

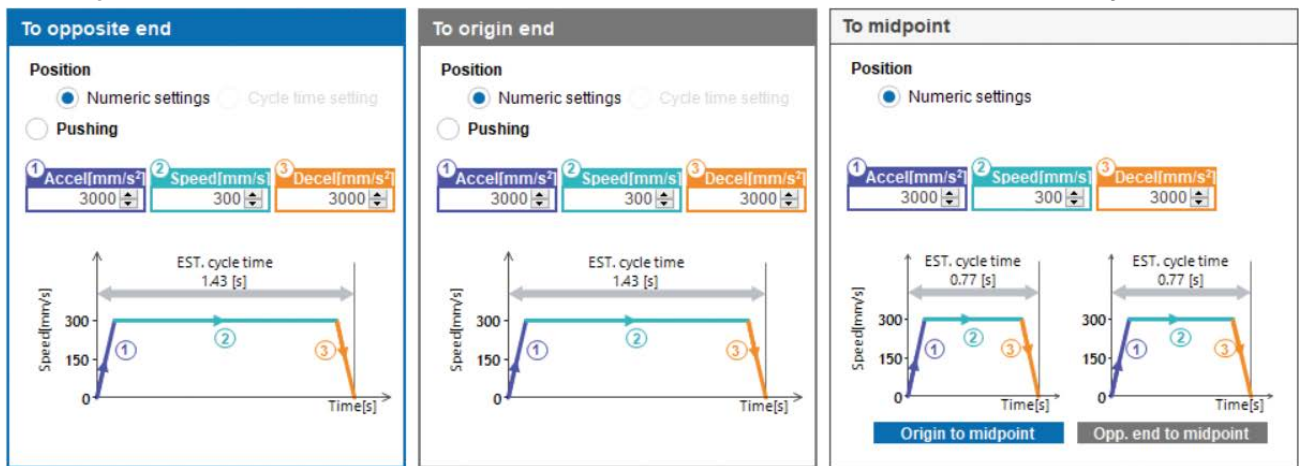

Setting complete

Test operation is possible immediately after setting up.

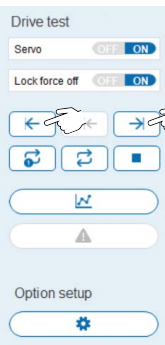

Just press the forward/backward button.

Cycle times are also *easily set*.

Cycle time can be set
in all operating modes.

For single solenoid (2-position)/ double solenoid (2-position) mode



Step 1 Forward and backward speeds, temporary setting of acceleration/deceleration

Operating Conditions

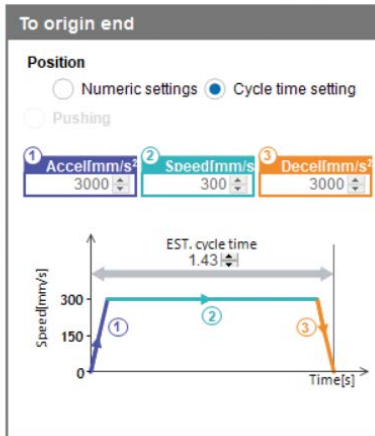
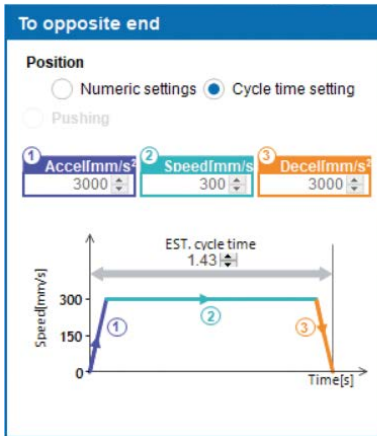

- * In these charts, settling time is not included.
- * The operating conditions to an intermediate point do not correspond to the cycle time setting.
- * Cycle time cannot be set for pushing operation.

Step 2 Operate one cycle and check the graph.

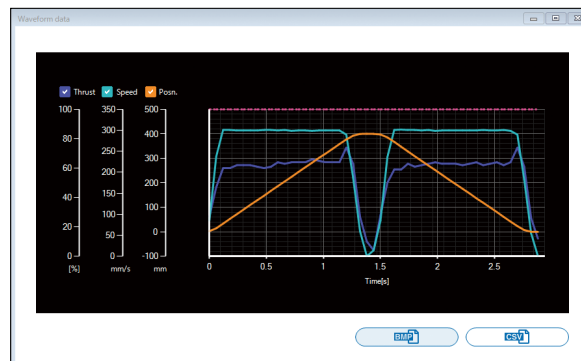
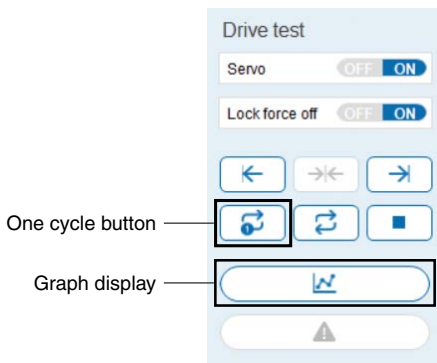

Green: Current speed
Blue: Current force
Orange: Current position

Setting complete Adjustable according to cycle time

Operating Conditions

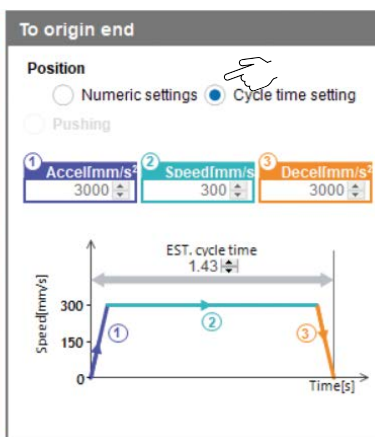
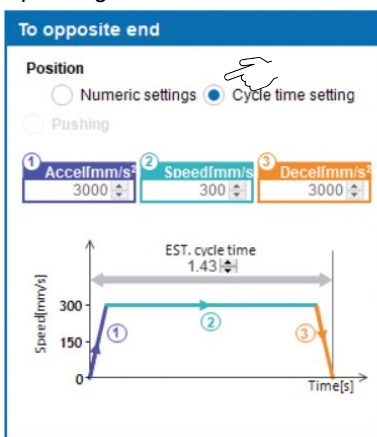

- * In these charts, settling time is not included.

Caution

The stop position can be changed. For use in positions other than the default setting, refer to the operation manual.



Operation manual

Annual CO₂ emissions reduced by up to 60% through motor control optimization (SMC comparison)

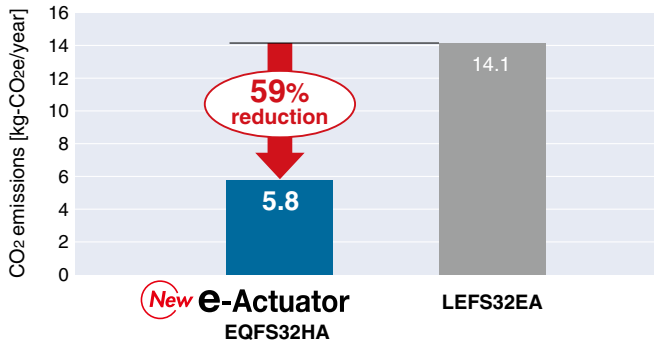

- Operating conditions
- Slider type, Size 32
 - Acceleration/Deceleration: 3000 mm/s²
 - Speed: 50 mm/s
 - Duty ratio: 20%

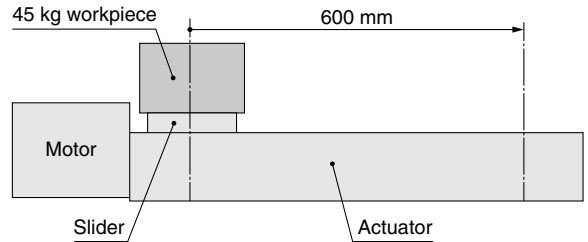

* The numerical values vary depending on the operating conditions.

Adopts metal connectors

PWR Green :

Lights up during normal operation after power on

ALM Red :

Lights up when an alarm is generated

OVL Orange :

Lights up when an overload condition occurs



Restart from the last stop position is possible.

Easy operation restart after recovery of the power supply

The position information is held by the encoder even when the power supply is turned off. A return to origin operation is not necessary when the power supply is recovered.

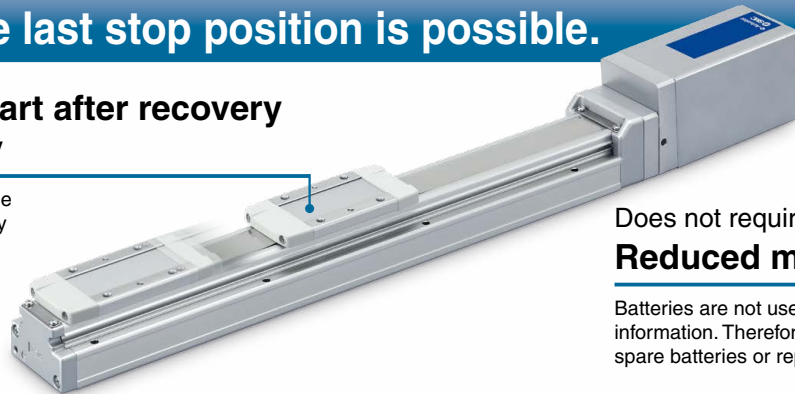

Does not require the use of batteries.

Reduced maintenance

Batteries are not used to store the position information. Therefore, there is no need to store spare batteries or replace dead batteries.

Auto switches are mountable.

2-color indicator solid state auto switch (Compatible with the D-M9□ series)

Accurate setting of the mounting position can be performed without mistakes.

A **green** light lights up when within the optimum operating range.

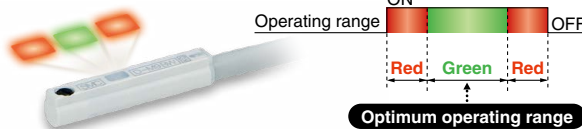

* The auto switches should be ordered separately. For details, refer to the [Web Catalog](#).

For the slider type

Allows for position detection of the table throughout the stroke

Size: 32



Size: 25

For the rod type

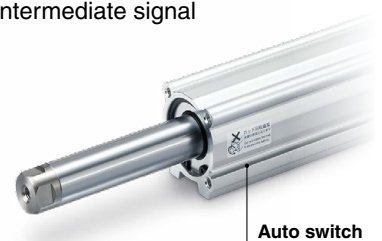
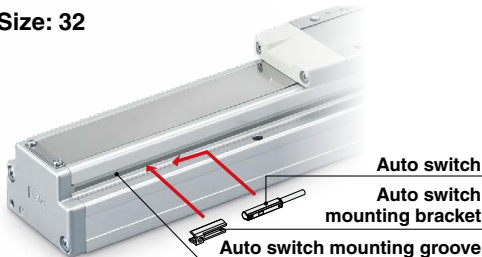
For checking the limit and the intermediate signal

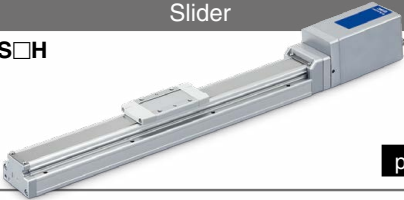

Variations

Type	Slider		Rod	
Series	EQFS□H  p. 6		EQY□H  p. 12	
Actuation type	Ball screw		Ball screw + Belt (In-line: Ball screw)	
Max. speed*1 [mm/s]	1200		500	
Positioning repeatability [mm]	±0.02		±0.02	
Drive motor	Battery-less absolute (Step motor 24 VDC) ●		●	
Power supply	24 VDC ±10%			
I/O signal	Parallel input: 3 inputs Parallel output: 4 outputs			
Operation mode	Positioning operation		Positioning operation Pushing operation (Excludes intermediate points)	
Size	25	●	●	
	32	●	●	
Max. work load [kg] <small>The values in parentheses are for when mounted vertically</small>	Size 25	40 (15)	70 (30)	
	Size 32	68 (20)	100 (46)	
Max. pushing force [N]	Size 25		452	
	Size 32		707	
Max. stroke [mm]	1000		500	
Auto switch mounting	●		●	

*1 The numerical values vary depending on the actuator type, work load, speed, and specifications. Please contact SMC for further details.

System Construction/General Purpose I/O

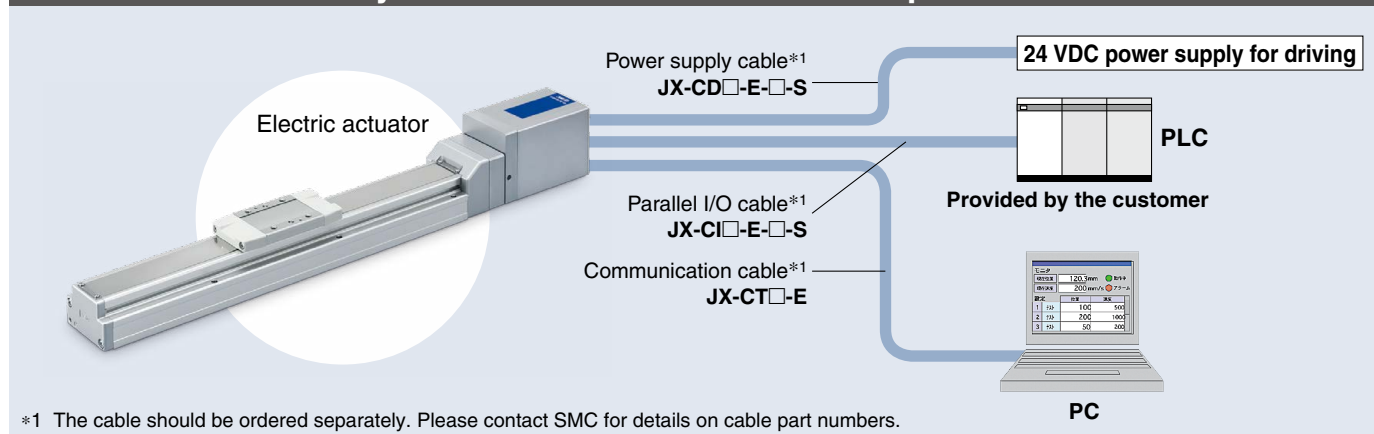

Battery-less Absolute (Step Motor 24 VDC)

e-Actuator Easy to Operate

Integrated Controller / Slider Type

EQFS□H Series EQFS25, 32



RoHS

How to Order

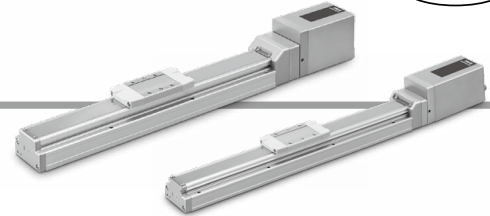

Integrated controller
Battery-less absolute
(Step motor 24 VDC)

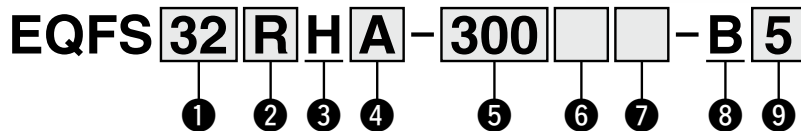

1 Size

25
32

2 Motor mounting position

Nil	In-line
R	Right side parallel
L	Left side parallel

3 Motor type

H	Battery-less absolute (Step motor 24 VDC)
---	--

4 Lead [mm]

Symbol	EQFS25	EQFS32
H	20	24
A	12	16
B	6	8
C	3	4

5 Stroke

50	50
to	to
1000	1000

* For details, refer to the applicable stroke table below.

6 Motor option

Nil	Without option
B	With lock

7 Grease application (Seal band part)

Nil	With
N	Without (Roller specification)

8 Controller position

B	Integrated controller
---	-----------------------

9 Parallel input

5	NPN
6	PNP

Applicable Stroke Table

Size	Stroke																			
	50	100	150	200	250	300	350	400	450	500	550	600	650	700	750	800	850	900	950	1000
25	●	●	●	●	●	●	●	●	●	●	●	●	●	●	●	●	—	—	—	—
32	●	●	●	●	●	●	●	●	●	●	●	●	●	●	●	●	●	●	●	●

For auto switches, refer to the **Web Catalog**.

Specifications

Model			EQFS25□H				EQFS32□H				
Actuator specifications	Stroke [mm] ^{*1}		50 to 800				50 to 1000				
	Work load [kg] ^{*2}		Horizontal	15	26	40	40	39.5	50	68	68
			Vertical	2	6	12.5	15	4	10	16	20
	Speed [mm/s]	Stroke range	Up to 400	20 to 1200	12 to 850	6 to 450	3 to 225	24 to 1100	16 to 750	8 to 450	4 to 125
			401 to 500	20 to 1100	12 to 750	6 to 400	3 to 225	24 to 1100	16 to 750	8 to 450	4 to 125
			501 to 600	20 to 900	12 to 540	6 to 270	3 to 135	24 to 1100	16 to 750	8 to 400	4 to 125
			601 to 700	20 to 630	12 to 420	6 to 230	3 to 115	24 to 930	16 to 620	8 to 310	4 to 125
			701 to 800	20 to 550	12 to 330	6 to 180	3 to 90	24 to 750	16 to 500	8 to 250	4 to 125
			801 to 900	—	—	—	—	24 to 610	16 to 410	8 to 200	4 to 100
			901 to 1000	—	—	—	—	24 to 500	16 to 340	8 to 170	4 to 85
	Max. acceleration/ deceleration [mm/s ²]		Horizontal	10000 (Varies depending on the work load and duty ratio ^{*2})							
			Vertical	5000 (Varies depending on the work load and duty ratio ^{*2})							
	Positioning repeatability [mm]		±0.02								
	Lost motion [mm] ^{*3}		0.1 or less								
Lead [mm]		20	12	6	3	24	16	8	4		
Impact/Vibration resistance [m/s ²] ^{*4}		50/20									
Actuation type		Ball screw (EQFS□H), Ball screw + Belt (EQFS□ ^R H)									
Guide type		Linear guide									
Operating temperature range [°C]		5 to 40									
Operating humidity range [%RH]		90 or less (No condensation)									
Electric specifications	Motor size		□42				□56.4				
	Motor type		Battery-less absolute (Step motor 24 VDC)								
	Encoder		Battery-less absolute								
	Power supply voltage [V]		24 VDC ±10%								
	Power [W] ^{*5 *7}		Max. power 89				Max. power 116				
Lock unit specifications	Type ^{*6}		Non-magnetizing lock								
	Holding force [N]		47	78	157	294	72	108	216	421	
	Power [W] ^{*7}		5				5				
Power supply voltage [V]		24 VDC ±10%									

*1 Please contact SMC for non-standard strokes as they are produced as special orders.

*2 The max. work load at 3000 mm/s² acceleration and deceleration speed
 Work load varies depending on the speed and acceleration. Please contact SMC for details.
 Furthermore, if the cable length exceeds 5 m, please contact SMC.

*3 A reference value for correcting errors in reciprocal operation

*4 Impact resistance: No malfunction occurred when the actuator was tested with a drop tester in both an axial direction and a perpendicular direction to the lead screw. (The test was performed with the actuator in the initial state.)
 Vibration resistance: No malfunction occurred in a test ranging between 45 to 2000 Hz. The test was performed in both an axial direction and a perpendicular direction to the lead screw. (The test was performed with the actuator in the initial state.)

*5 Indicates the max. power during operation
 This value can be used for the selection of the power supply.

*6 With lock only

*7 For an actuator with lock, add the power for the lock.

Dimensions: In-line Motor

EQFS25H

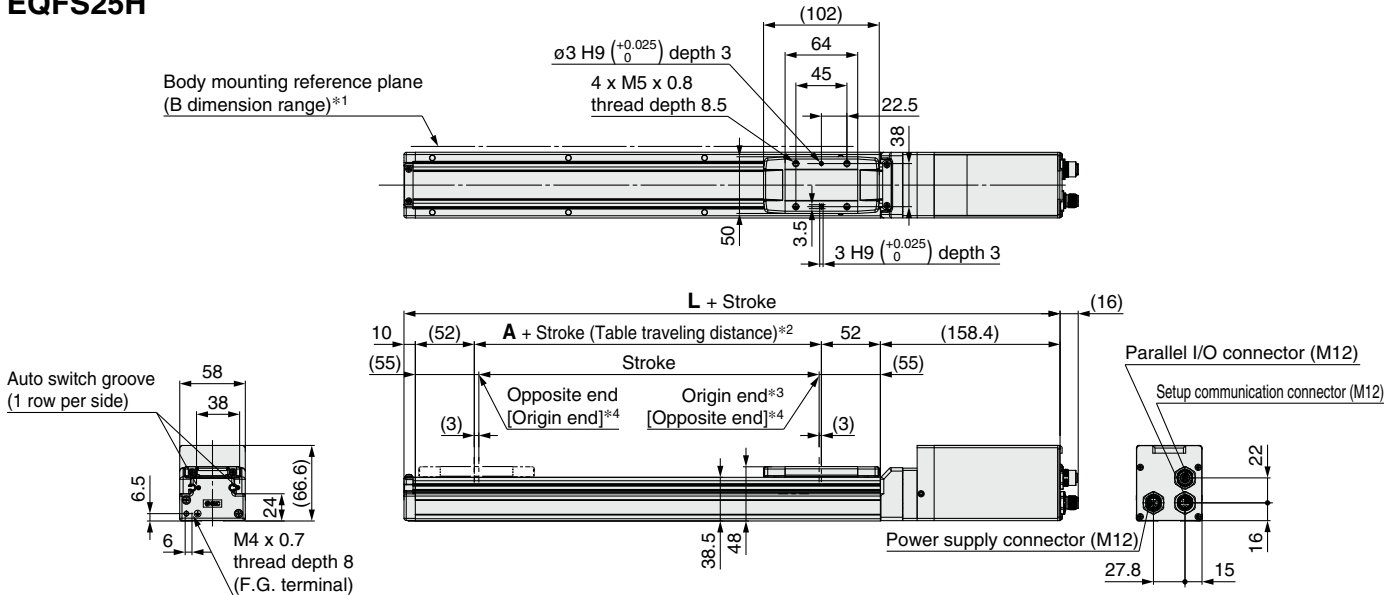

Motor option: With lock

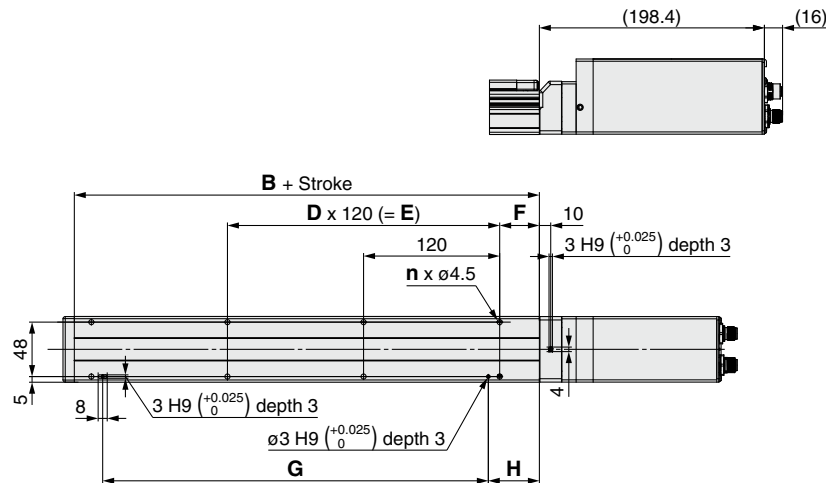

- *1 When mounting the actuator using the body mounting reference plane, set the height of the opposite surface or pin to be 3 mm or more. (Recommended height: 5 mm)
 In addition, be aware that surfaces other than the body mounting reference plane (B dimension range) may slightly protrude from the body mounting reference plane. Be sure to provide a clearance of 1 mm or more to avoid interference with workpieces, facilities, etc.
- *2 The distance the table moves according to movement instructions
 Make sure that workpieces mounted on the table do not interfere with other workpieces or the facilities around the table.
- *3 Indicates the factory default origin position (0 mm)
- *4 [] refers to when the rotation direction reference is changed.

Dimensions

Stroke [mm]	L		A	B	n	D	E	F	G	H
	Without lock	With lock								
50	278.4	318.4	6	110	4	—	—	25	100	45
100, 150					6	2	240			
200, 250					8	3	360	35	220	
300, 350, 400					10	4	480			
450, 500					12	5	600	340		
550, 600, 650					14	6	720			
700, 750					16	7	840	460		
800									580	
					700					
					820					

Dimensions: In-line Motor

EQFS32H

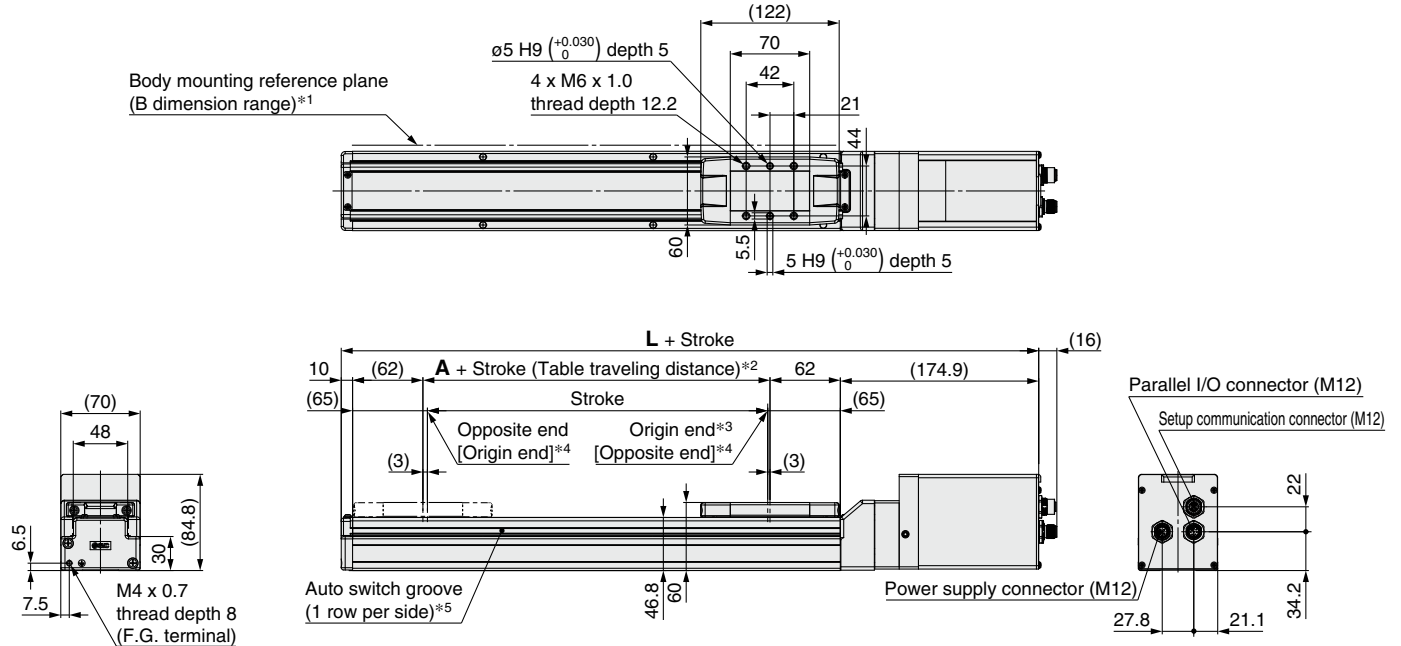

Motor option: With lock

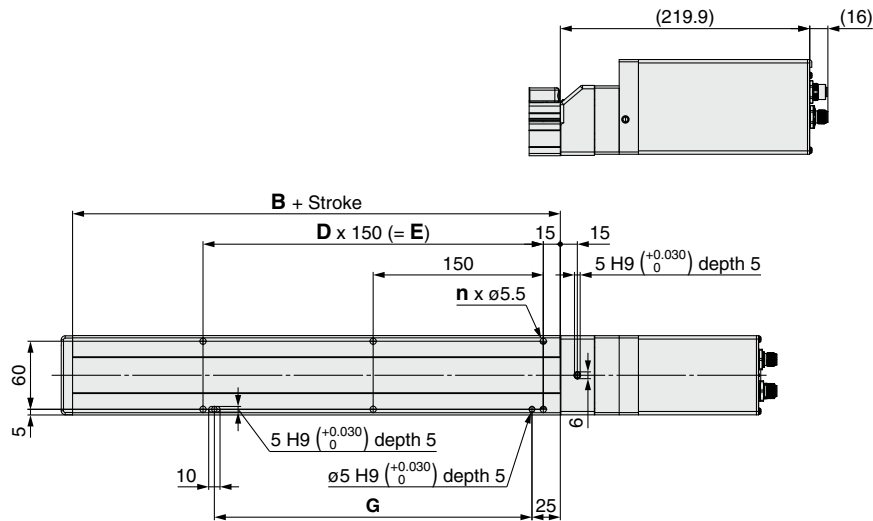

- *1 When mounting the actuator using the body mounting reference plane, set the height of the opposite surface or pin to be 3 mm or more. (Recommended height: 5 mm)
 In addition, be aware that surfaces other than the body mounting reference plane (B dimension range) may slightly protrude from the body mounting reference plane. Be sure to provide a clearance of 1 mm or more to avoid interference with workpieces, facilities, etc.
- *2 The distance the table moves according to movement instructions
 Make sure that workpieces mounted on the table do not interfere with other workpieces or the facilities around the table.
- *3 Indicates the factory default origin position (0 mm)
- *4 [] refers to when the rotation direction reference is changed.
- *5 A switch spacer (BM3-016) is required to secure auto switches. Please order it separately.

Dimensions

Stroke [mm]	L		A	B	n	D	E	G
	Without lock	With lock						
50, 100, 150	314.9	359.9	6	130	4	—	—	130
200, 250, 300					6	2	300	280
350, 400, 450					8	3	450	430
500, 550, 600					10	4	600	580
650, 700, 750					12	5	750	730
800, 850, 900					14	6	900	880
950, 1000					16	7	1050	1030

Dimensions: Right/Left Side Parallel Motor

EQFS25RH

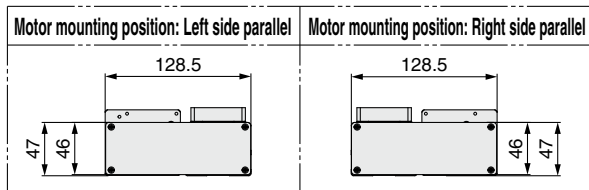
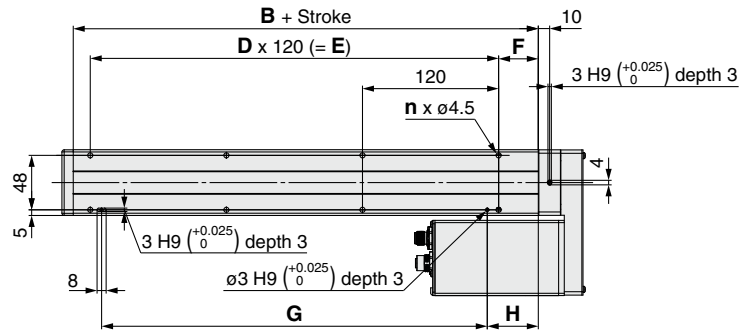
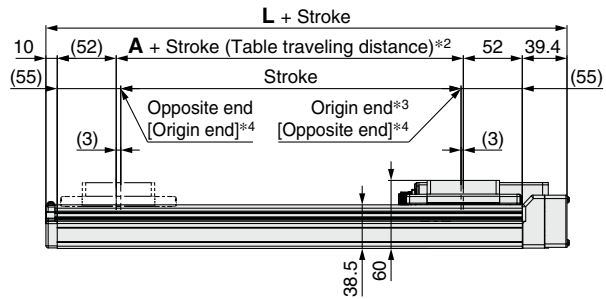
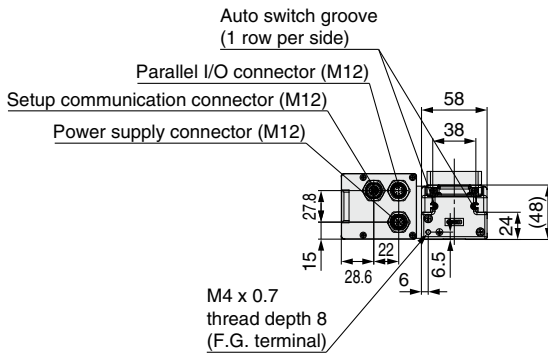
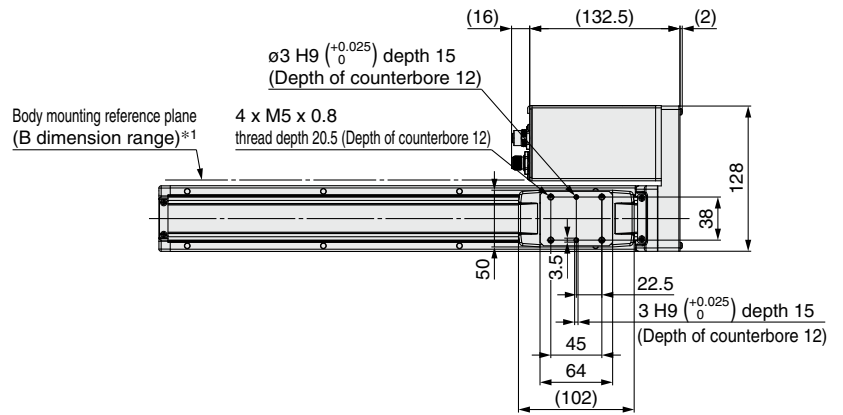
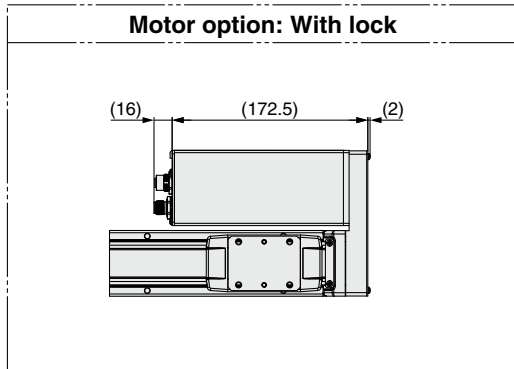

- *1 When mounting the actuator using the body mounting reference plane, set the height of the opposite surface or pin to be 3 mm or more. (Recommended height: 5 mm)
In addition, be aware that surfaces other than the body mounting reference plane (B dimension range) may slightly protrude from the body mounting reference plane. Be sure to provide a clearance of 1 mm or more to avoid interference with workpieces, facilities, etc.
- *2 The distance the table moves according to movement instructions
Make sure that workpieces mounted on the table do not interfere with other workpieces or the facilities around the table.
- *3 Indicates the factory default origin position (0 mm)
- *4 [] refers to when the rotation direction reference is changed.

Dimensions

Stroke [mm]	L	A	B	n	D	E	F	G	H
50	159.4	6	110	4	—	—	25	100	30
100, 150				6	2	240	220	45	
200, 250				8	3	360	340		
300, 350, 400				10	4	480	460		
450, 500				12	5	600	580		
550, 600, 650				14	6	720	700		
700, 750				16	7	840	820		
800									

Dimensions: Right/Left Side Parallel Motor

EQFS32RH

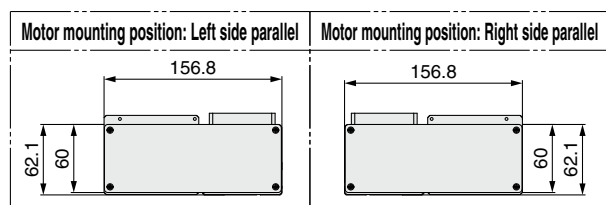
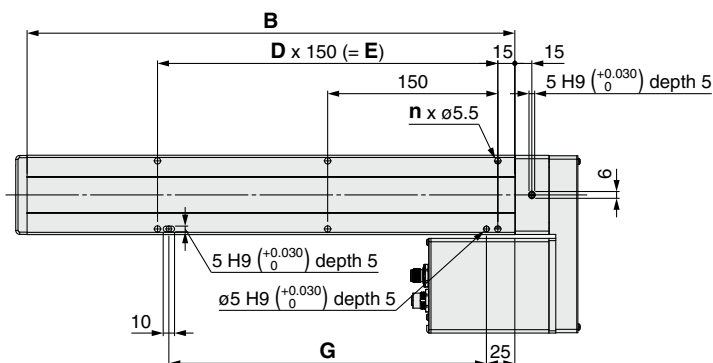
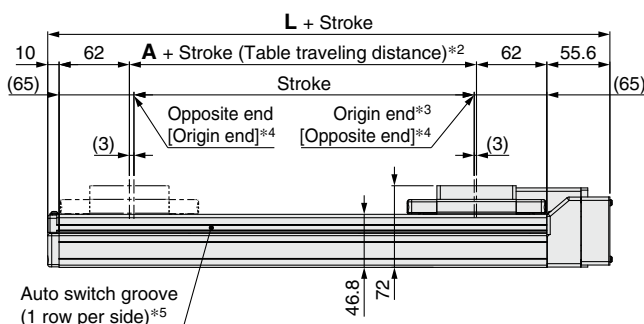
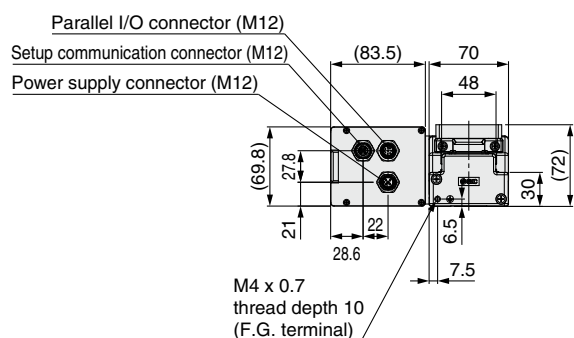
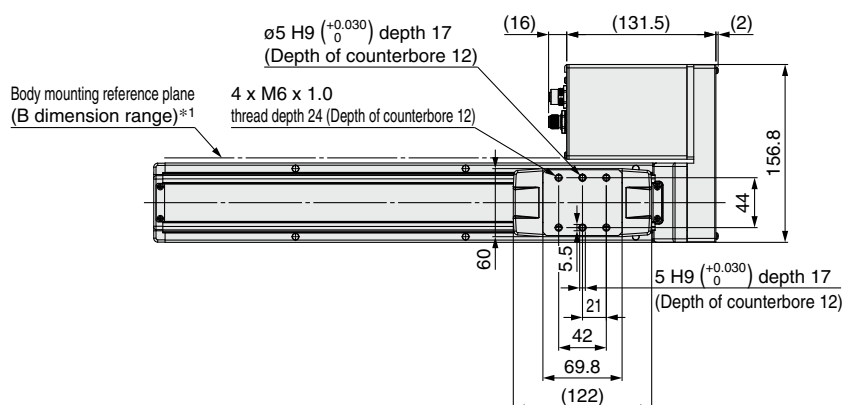
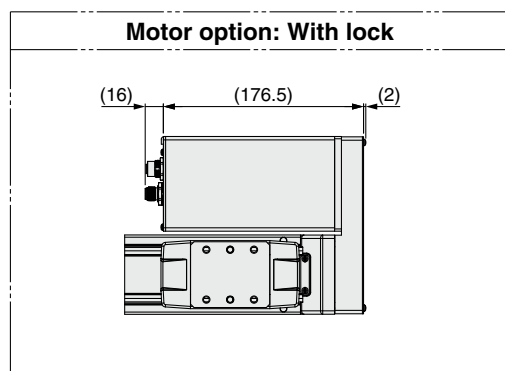

- *1 When mounting the actuator using the body mounting reference plane, set the height of the opposite surface or pin to be 3 mm or more. (Recommended height: 5 mm)
 In addition, be aware that surfaces other than the body mounting reference plane (B dimension range) may slightly protrude from the body mounting reference plane. Be sure to provide a clearance of 1 mm or more to avoid interference with workpieces, facilities, etc.
- *2 The distance the table moves according to movement instructions
 Make sure that workpieces mounted on the table do not interfere with other workpieces or the facilities around the table.
- *3 Indicates the factory default origin position (0 mm)
- *4 [] refers to when the rotation direction reference is changed.
- *5 A switch spacer (BM3-016) is required to secure auto switches. Please order it separately.

Dimensions

	[mm]						
Stroke [mm]	L	A	B	n	D	E	G
50, 100, 150	195.6	6	130	4	—	—	130
200, 250, 300				6	2	300	280
350, 400, 450				8	3	450	430
500, 550, 600				10	4	600	580
650, 700, 750				12	5	750	730
800, 850, 900				14	6	900	880
950, 1000				16	7	1050	1030

Battery-less Absolute (Step Motor 24 VDC)

e-Actuator Easy to Operate

Integrated Controller / Rod Type

EQY□H Series EQY25, 32



RoHS

How to Order

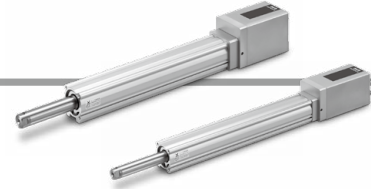

Integrated controller
Battery-less absolute
(Step motor 24 VDC)

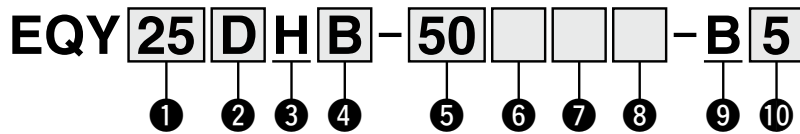

1 Size

25
32

2 Motor mounting position

Nil	Top side parallel
R	Right side parallel
L	Left side parallel
D	In-line

3 Motor type

H	Battery-less absolute (Step motor 24 VDC)
---	--

4 Lead [mm]

Symbol	EQY25	EQY32
H	20	24
A	12	16
B	6	8
C	3	4

5 Stroke [mm]

30	30
to	to
500	500

* For details, refer to the applicable stroke table below.

6 Motor option

Nil	Without option
B	With lock

7 Rod end thread

Nil	Rod end female thread
M	Rod end male thread (1 rod end nut is included.)

8 Mounting*1

Symbol	Type	Motor mounting position	
		Parallel	In-line
Nil	Ends tapped*2 Body bottom tapped	●	●
L	Foot bracket	●	—
F	Rod flange*2	●	●
G	Head flange*2	●*4	—
D	Double clevis*3	●	—

*1 The mounting bracket is shipped together with the product but does not come assembled.

*2 For the horizontal cantilever mounting of the rod flange or ends tapped types, use the actuator within the following stroke range.

· EQY25: 200 or less · EQY32: 100 or less

*3 For the mounting of the double clevis type, use the actuator within the following stroke range.

· EQY25: 200 or less · EQY32: 200 or less

*4 The head flange type is not available for the EQY32.

9 Controller position

B	Integrated controller
---	-----------------------

10 Parallel input

5	NPN
6	PNP

Applicable Stroke Table

Size	Stroke [mm]											Manufacturable stroke range
	30	50	100	150	200	250	300	350	400	450	500	
25	●	●	●	●	●	●	●	●	●	—	—	15 to 400
32	●	●	●	●	●	●	●	●	●	●	●	20 to 500

For auto switches, refer to the Web Catalog.

Specifications

Model		EQY25□H				EQY32□H					
Actuator specifications	Stroke [mm]	30 to 400				30 to 500					
	Work load [kg]*1	Horizontal	8	26	40	70	30	50	90	100	
		Vertical	2	8	16	30	3	13	26	46	
	Pushing force [N]*2 *3 *4		36 to 76	63 to 122	126 to 238	232 to 452	50 to 118	80 to 189	156 to 370	296 to 707	
	Speed [mm/s]	Stroke range	Up to 300	30 to 900	18 to 700	9 to 450	5 to 225	30 to 900	24 to 800	12 to 400	6 to 200
			350 to 400	30 to 900	18 to 600	9 to 300	5 to 150	30 to 900	24 to 640	12 to 320	6 to 160
			450 to 500	—	—	—	—	30 to 900	24 to 640	12 to 320	6 to 160
	Max. acceleration/ deceleration [mm/s ²]	Horizontal	10000 (Varies depending on the work load and duty ratio*1)								
		Vertical	5000 (Varies depending on the work load and duty ratio*1)								
	Pushing speed [mm/s ²]*5		35 or less				30 or less				
	Positioning repeatability [mm]		±0.02								
	Lost motion [mm]*6		0.1 or less								
	Lead [mm]		20	12	6	3	24	16	8	4	
Impact/Vibration resistance [m/s ²]*7		50/20									
Actuation type		Ball screw + Belt (EQY□H), Ball screw (EQY□DH)									
Guide type		Sliding bushing (Piston rod)									
Operating temperature range [°C]		5 to 40									
Operating humidity range [%RH]		90 or less (No condensation)									
Electric specifications	Motor size	□42				□56.4					
	Motor type	Battery-less absolute (Step motor 24 VDC)									
	Encoder	Battery-less absolute									
	Power supply voltage [V]	24 VDC ±10%									
Lock unit specifications	Power [W]*8 *9	Max. power 86				Max. power 109					
	Type*10	Non-magnetizing lock									
	Holding force [N]	47	78	157	294	75	108	216	421		
	Power [W]*9	5				5					
Power supply voltage [V]		24 VDC ±10%									

*1 Horizontal: Please use an external guide (friction coefficient: 0.1 or less). The work load shows the maximum value. The actual work load and transfer speed change according to the condition of the external guide.

For the speed, acceleration, and duty ratio according to the work load, please contact SMC.

Vertical: If the rod orientation is vertical or radial load is applied to the rod, please use an external guide (friction coefficient: 0.1 or less). The work load represents the maximum value. The actual work load and transfer speed change according to the condition of the external guide.

For the speed, acceleration, and duty ratio according to the work load, please contact SMC.

The values shown in () are the max. acceleration/deceleration.

Set the acceleration/deceleration speed to 10000 [mm/s²] or less for the horizontal direction and 5000 [mm/s²] or less for the vertical direction.

*2 Pushing force accuracy is ±20% (F.S.).

*3 The pushing force set values for EQY25□H are 25% to 50%, and for EQY32□H are 30% to 70%.

The pushing force values change according to the duty ratio and pushing speed. Please contact SMC for details.

*4 The speed and force may change depending on the cable length, load, and mounting conditions. Furthermore, if the cable length exceeds 5 m, then it will decrease by up to 10% for each 5 m. (At 15 m: Reduced by up to 20%)

*5 The allowable speed for pushing operation. When push conveying a workpiece, operate at the vertical work load or less.

*6 A reference value for correcting errors in reciprocal operation

*7 Impact resistance: No malfunction occurred when the actuator was tested with a drop tester in both an axial direction and a perpendicular direction to the lead screw. (The test was performed with the actuator in the initial state.)

Vibration resistance: No malfunction occurred in a test ranging between 45 to 2000 Hz. The test was performed in both an axial direction and a perpendicular direction to the lead screw. (The test was performed with the actuator in the initial state.)

*8 Indicates the max. power during operation. This value can be used for the selection of the power supply.

*9 For an actuator with lock, add the power for the lock.

*10 With lock only

Dimensions: Top Side Parallel Motor

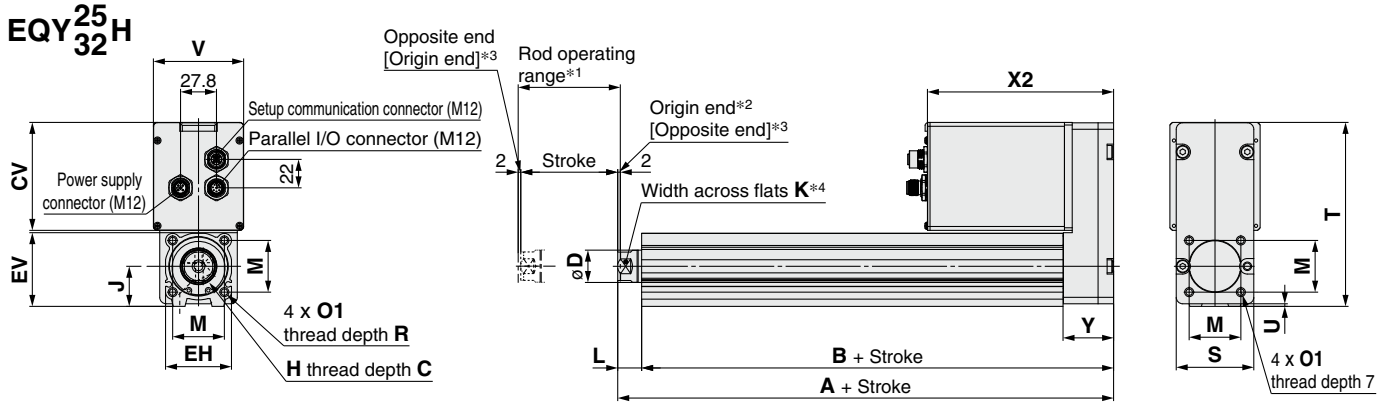

Motor option: With lock

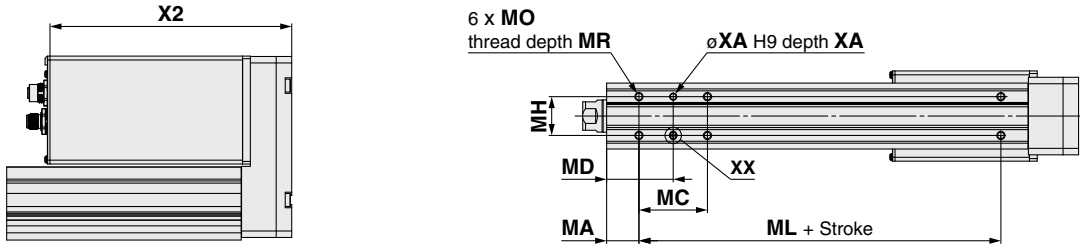

Motor mounting position

Left side parallel Right side parallel

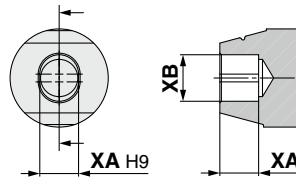
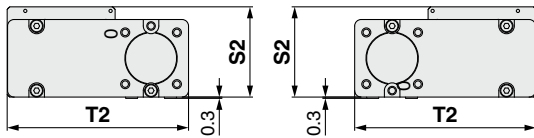

XX (2:1)

- *1 The range of movement of the rod according to the movement instructions. Make sure that workpieces mounted on the rod do not interfere with other workpieces or the facilities around the rod.
- *2 Indicates the factory default origin position (0 mm)
- *3 [] refers to when the rotation direction reference is changed.
- *4 The direction of rod end width across flats differs depending on the products.

Dimensions

Size	Stroke range [mm]	A	B	C	D	EH	EV	H	J	K	L	M	O1	R	S	S2	T	T2	U	CV	V	X2		Y
																						Without lock	With lock	
25	15 to 100	136.2	121.7	13	20	44	45.5	M8 x 1.25	24	17	14.5	34	M5 x 0.8	8	46	58.1	115	113.6	1	66.3	57.8	144	184	32.2
	101 to 400	161.2	146.7																					
32	20 to 100	153.6	135.1	13	25	51	56.5	M8 x 1.25	31	22	18.5	40	M6 x 1	10	60	70.8	142	140.3	2	83.5	69.8	144	187	39.1
	101 to 500	183.6	165.1																					

Body Bottom Tapped

Size	Stroke range [mm]	MA	MC	MD	MH	ML	MO	MR	XA	XB
25	15 to 39	20	24	32	29	50	M5 x 0.8	6.5	4	5
	40 to 100		42	41		75				
	101 to 124		59	49.5		75				
	125 to 200		76	58						
	201 to 400		76	58						
32	20 to 39	25	22	36	30	50	M6 x 1	8.5	5	6
	40 to 100		36	43		80				
	101 to 124		53	51.5		80				
	125 to 200		70	60						
	201 to 500		70	60						

Dimensions: In-line Motor

EQY²⁵₃₂DH

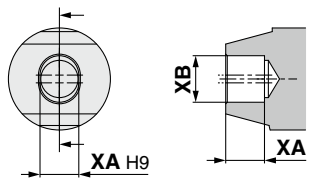
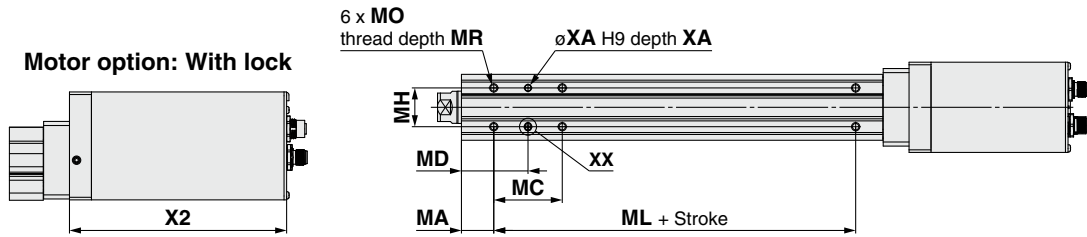
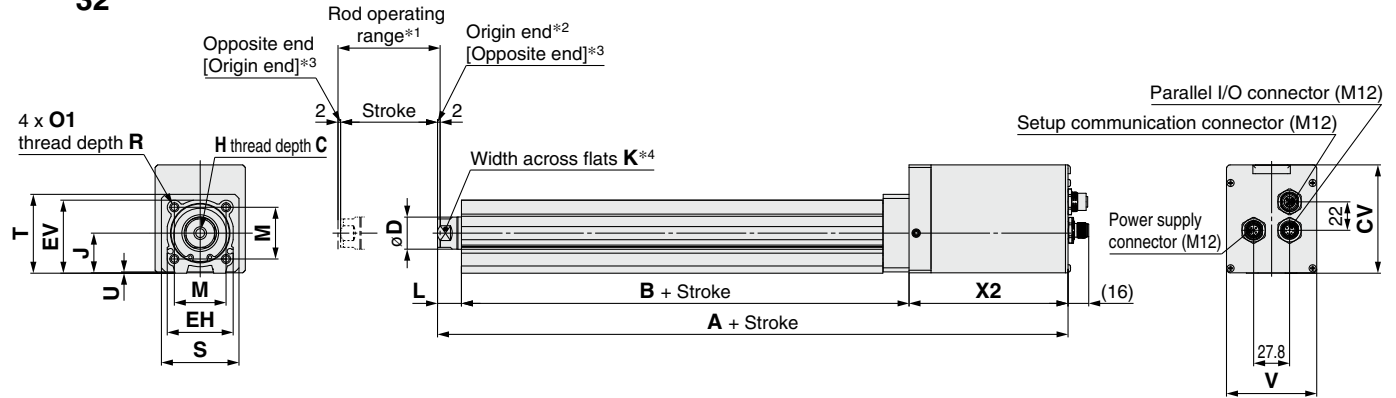

XX (2:1)

- *1 The range of movement of the rod according to the movement instructions. Make sure that workpieces mounted on the rod do not interfere with other workpieces or the facilities around the rod.
- *2 Indicates the factory default origin position (0 mm)
- *3 [] refers to when the rotation direction reference is changed.
- *4 The direction of rod end width across flats differs depending on the products.

Dimensions

Size	Stroke range [mm]	A		B	C	D	EH	EV	H	J	K	L	M	O1	R	S	T	U	V	X2		CV
		Without lock	With lock																	Without lock	With lock	
25	15 to 100	243.4	283.4	102.9	13	20	44	45.5	M8 x 1.25	24	17	14.5	34	M5 x 0.8	8	45	46.5	1.5	57.8	126	166	66.6
	101 to 400	268.4	308.4	127.9																		
32	20 to 100	257.8	302.8	116.3	13	25	51	56.5	M8 x 1.25	31	22	18.5	40	M6 x 1	10	60	61	1	69.8	123	168	83.8
	101 to 500	287.8	332.8	146.3																		

Body Bottom Tapped

Size	Stroke range [mm]	MA	MC	MD	MH	ML	MO	MR	XA	XB
25	15 to 39	20	24	32	29	50	M5 x 0.8	6.5	4	5
	40 to 100		42	41		75				
	101 to 124		59	49.5						
	125 to 200		76	58						
	201 to 400									
32	20 to 39	25	22	36	30	50	M6 x 1	8.5	5	6
	40 to 100		36	43		80				
	101 to 124		53	51.5						
	125 to 200		70	60						
	201 to 500									

Dimensions

End male thread: EQY²⁵₃₂□H^A□□M
B
C

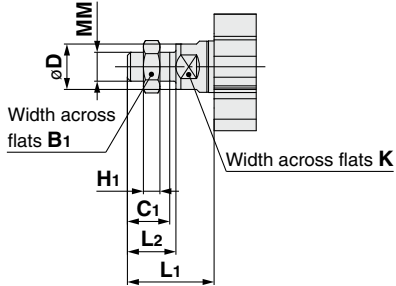

End Male Thread

Size	B ₁	C ₁	øD	H ₁	K	L ₁	L ₂	MM
25	22	20.5	20	8	17	38	23.5	M14 x 1.5
32	22	20.5	25	8	22	42	23.5	M14 x 1.5

* The L₁ measurement is when the unit is in the original position. At this position, 2 mm at the end.

* Refer to the **Web Catalog** for details on the rod end nut and mounting bracket.
 * Refer to the specific product precautions ("Handling") in the **Web Catalog** when mounting end brackets such as knuckle joint or workpieces.

Foot bracket: EQY²⁵₃₂□H^A□□L
B
C

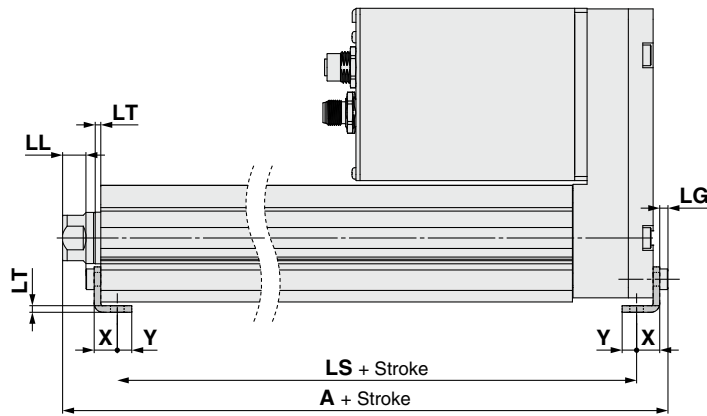
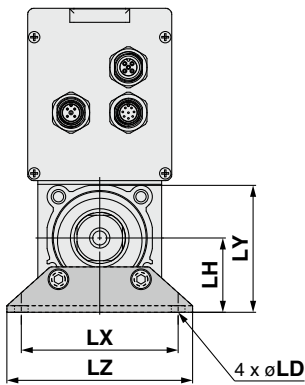

Outward mounting

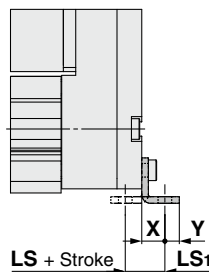

Included parts
 · Foot bracket
 · Body mounting bolt

Foot Bracket

Size	Stroke range [mm]	A	LS	LS ₁	LL	LD	LG	LH	LT	LX	LY	LZ	X	Y
25	30 to 100	142.3	104.5	19.8	8.4	6.6	3.5	30	2.6	57	51.5	71	11.2	5.8
	101 to 400	167.3	129.5											
32	30 to 100	160.8	119.1	19.2	11.3	6.6	4	36	3.2	76	61.5	90	11.2	7
	101 to 500	190.8	149.1											

Material: Carbon steel (Chromating)

* The A measurement is when the unit is in the original position. At this position, 2 mm at the end.

* When the motor mounting is the right or left side parallel type, the head side foot bracket should be mounted outward.

Dimensions

Rod flange: EQY $\frac{25}{32}$ □H $\frac{A}{B}$ - □□□F
 C

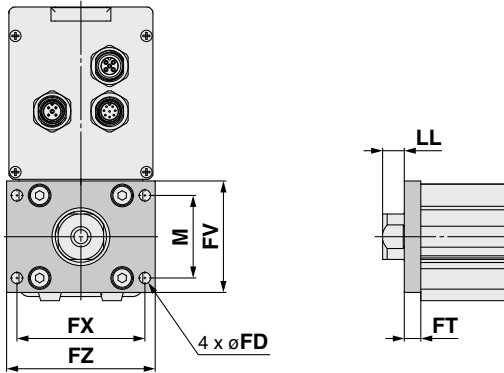

Head flange: EQY $\frac{25}{32}$ H $\frac{A}{B}$ - □□□G
 C

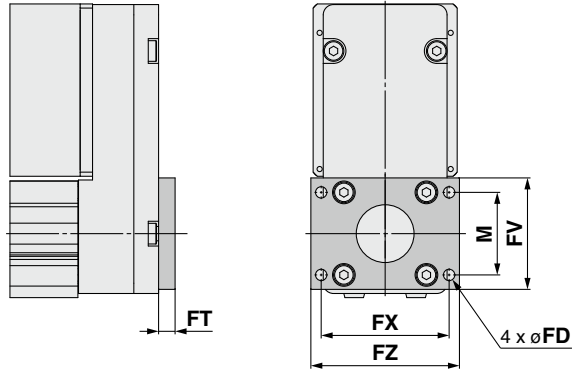

* The head flange type is not available for the EQY32.

Included parts
 · Flange
 · Body mounting bolt

Rod/Head Flange [mm]

Size	FD	FT	FV	FX	FZ	LL	M
25	5.5	8	48	56	65	6.5	34
32	5.5	8	54	62	72	10.5	40

Material: Carbon steel (Nickel plating)

Double clevis: EQY $\frac{25}{32}$ H $\frac{A}{B}$ - □□□D
 C

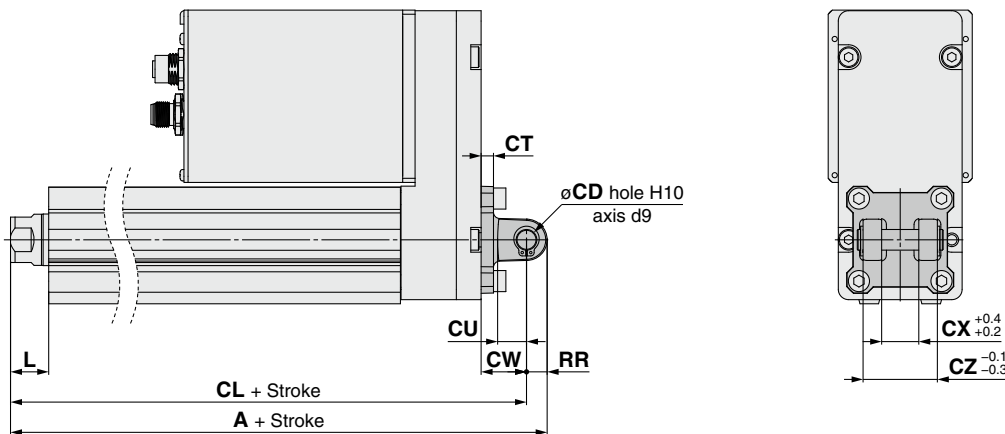

Included parts
 · Double clevis
 · Body mounting bolt
 · Clevis pin
 · Retaining ring

For the models and dimensions of the mounting bracket and simple joint bracket, refer to the **Web Catalog** for the LEY series.

* Refer to the **Web Catalog** for details on the rod end nut and mounting bracket.

Double Clevis [mm]

Size	Stroke range [mm]	A	CL	CD	CT	CU	CW	CX	CZ	L	RR
25	30 to 100	166.2	156.2	10	5	14	20	18	36	14.5	10
	101 to 200	191.2	181.2								
32	30 to 100	185.6	175.6	10	6	14	22	18	36	18.5	10
	101 to 200	215.6	205.6								

Material: Cast iron (Coating)

* The A and CL measurements are when the unit is in the original position. At this position, 2 mm at the end.

Safety Instructions

These safety instructions are intended to prevent hazardous situations and/or equipment damage. These instructions indicate the level of potential hazard with the labels of “**Caution**,” “**Warning**” or “**Danger**.” They are all important notes for safety and must be followed in addition to International Standards (ISO/IEC)*1), and other safety regulations.

 **Caution:** **Caution** indicates a hazard with a low level of risk which, if not avoided, could result in minor or moderate injury.

 **Warning:** **Warning** indicates a hazard with a medium level of risk which, if not avoided, could result in death or serious injury.

 **Danger :** **Danger** indicates a hazard with a high level of risk which, if not avoided, will result in death or serious injury.

*1) ISO 4414: Pneumatic fluid power – General rules relating to systems.
ISO 4413: Hydraulic fluid power – General rules relating to systems.
IEC 60204-1: Safety of machinery – Electrical equipment of machines.
(Part 1: General requirements)
ISO 10218-1: Manipulating industrial robots – Safety.
etc.

Warning

1. The compatibility of the product is the responsibility of the person who designs the equipment or decides its specifications.

Since the product specified here is used under various operating conditions, its compatibility with specific equipment must be decided by the person who designs the equipment or decides its specifications based on necessary analysis and test results. The expected performance and safety assurance of the equipment will be the responsibility of the person who has determined its compatibility with the product. This person should also continuously review all specifications of the product referring to its latest catalog information, with a view to giving due consideration to any possibility of equipment failure when configuring the equipment.

2. Only personnel with appropriate training should operate machinery and equipment.

The product specified here may become unsafe if handled incorrectly. The assembly, operation and maintenance of machines or equipment including our products must be performed by an operator who is appropriately trained and experienced.

3. Do not service or attempt to remove product and machinery/equipment until safety is confirmed.

1. The inspection and maintenance of machinery/equipment should only be performed after measures to prevent falling or runaway of the driven objects have been confirmed.
2. When the product is to be removed, confirm that the safety measures as mentioned above are implemented and the power from any appropriate source is cut, and read and understand the specific product precautions of all relevant products carefully.
3. Before machinery/equipment is restarted, take measures to prevent unexpected operation and malfunction.

4. Contact SMC beforehand and take special consideration of safety measures if the product is to be used in any of the following conditions.

1. Conditions and environments outside of the given specifications, or use outdoors or in a place exposed to direct sunlight.
2. Installation on equipment in conjunction with atomic energy, railways, air navigation, space, shipping, vehicles, military, medical treatment, combustion and recreation, or equipment in contact with food and beverages, emergency stop circuits, clutch and brake circuits in press applications, safety equipment or other applications unsuitable for the standard specifications described in the product catalog.
3. An application which could have negative effects on people, property, or animals requiring special safety analysis.
4. Use in an interlock circuit, which requires the provision of double interlock for possible failure by using a mechanical protective function, and periodical checks to confirm proper operation.

Caution

1. The product is provided for use in manufacturing industries.

The product herein described is basically provided for peaceful use in manufacturing industries.
If considering using the product in other industries, consult SMC beforehand and exchange specifications or a contract if necessary.
If anything is unclear, contact your nearest sales branch.

Limited warranty and Disclaimer/ Compliance Requirements

The product used is subject to the following “Limited warranty and Disclaimer” and “Compliance Requirements”.

Read and accept them before using the product.

Limited warranty and Disclaimer

1. The warranty period of the product is 1 year in service or 1.5 years after the product is delivered, whichever is first.*2)
Also, the product may have specified durability, running distance or replacement parts. Please consult your nearest sales branch.
2. For any failure or damage reported within the warranty period which is clearly our responsibility, a replacement product or necessary parts will be provided.
This limited warranty applies only to our product independently, and not to any other damage incurred due to the failure of the product.
3. Prior to using SMC products, please read and understand the warranty terms and disclaimers noted in the specified catalog for the particular products.

*2) Vacuum pads are excluded from this 1 year warranty.

A vacuum pad is a consumable part, so it is warranted for a year after it is delivered.
Also, even within the warranty period, the wear of a product due to the use of the vacuum pad or failure due to the deterioration of rubber material are not covered by the limited warranty.

Compliance Requirements

1. The use of SMC products with production equipment for the manufacture of weapons of mass destruction (WMD) or any other weapon is strictly prohibited.
2. The exports of SMC products or technology from one country to another are governed by the relevant security laws and regulations of the countries involved in the transaction. Prior to the shipment of a SMC product to another country, assure that all local rules governing that export are known and followed.

Caution

SMC products are not intended for use as instruments for legal metrology.

Measurement instruments that SMC manufactures or sells have not been qualified by type approval tests relevant to the metrology (measurement) laws of each country. Therefore, SMC products cannot be used for business or certification ordained by the metrology (measurement) laws of each country.

 **Safety Instructions** Be sure to read the “Handling Precautions for SMC Products” (M-E03-3) and “Operation Manual” before use.

SMC Corporation

Akihabara UDX 15F,
4-14-1, Sotokanda, Chiyoda-ku, Tokyo 101-0021, JAPAN
Phone: 03-5207-8249 Fax: 03-5298-5362
<https://www.smcworld.com>
© 2023 SMC Corporation All Rights Reserved

Specifications are subject to change without prior notice and any obligation on the part of the manufacturer.

D-G