

AC Servo Motor Driver



**Pulse Input Type/
Positioning Type** p. 13

**Incremental Type
LECSA Series**



Pulse Input Type p. 13

**Absolute Type
LECSB Series**



CC-Link Direct Input Type p. 13

**Absolute Type
LECSC Series**

CC-Link



SSCNET III Type p. 13

**Absolute Type
LECSS Series**

SSCNET III
SERVO SYSTEM CONTROLLER NETWORK

e-Factory Alliance



New **Pulse Input Type/
Positioning Type** p. 13

**Absolute Type
LECSB-T Series**



New **CC-Link
Direct Input Type** p. 13

**Absolute Type
LECSC-T Series**

CC-Link



SSCNET III/H Type p. 13

**Absolute Type
LECSS-T Series**

SSCNET III/H
SERVO SYSTEM CONTROLLER NETWORK

e-Factory Alliance

UL US LISTED



MECHATROLINK-II Type p. 37

**Absolute Type
LECYM Series**

MECHATROLINK-II



MECHATROLINK-III Type p. 37

**Absolute Type
LECYU Series**

MECHATROLINK-III









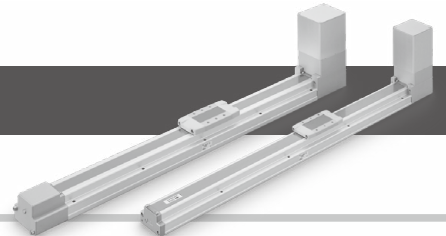

LECS□/LECS□-T/LECY□ Series



AC Servo Motor Driver

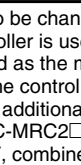

LECS□/LECS□-T/LECY□ Series List

Series	Compatible motor			Control method			Application/Function		Compatible option	
	100 W	200 W	400 W	Positioning ^{*1}	Pulse	Network direct input	Synchronous ^{*2}	Pushing operation ^{*4}	Setup software	
Incremental Type	 LECSA (Pulse input type/ Positioning type)	<input type="checkbox"/>	<input type="checkbox"/>	<input type="checkbox"/>	Up to 7 points	<input type="checkbox"/>			LEC-MRC2	
		<input type="checkbox"/>	<input type="checkbox"/>	<input type="checkbox"/>		<input type="checkbox"/>			LEC-MRC2	
	 LECSB (Pulse input type)	<input type="checkbox"/>	<input type="checkbox"/>	<input type="checkbox"/>		<input type="checkbox"/>			LEC-MRC2	
		 CC-Link LECSB (Pulse input type)	<input type="checkbox"/>	<input type="checkbox"/>	<input type="checkbox"/>	Up to 255 points		CC-Link Ver.1.10		LEC-MRC2
	 SSCNET III SERVO SYSTEM CONTROLLER NETWORK LECSB (SSCNET III type) Compatible with Mitsubishi Electric's servo system controller network		<input type="checkbox"/>	<input type="checkbox"/>	<input type="checkbox"/>			SSCNET III	<input type="checkbox"/>	<input type="checkbox"/>
		 LECSB-T (Pulse input type/ Positioning type)	<input type="checkbox"/>	<input type="checkbox"/>	<input type="checkbox"/>	Up to 255 points	<input type="checkbox"/>		<input type="checkbox"/>	LEC-MRC2
	 CC-Link LECSB-T (Pulse input type/ Positioning type)		<input type="checkbox"/>	<input type="checkbox"/>	<input type="checkbox"/>	Up to 255 points		CC-Link Ver.1.10		LEC-MRC2
		 SSCNET III/H SERVO SYSTEM CONTROLLER NETWORK LECSB-T (SSCNET III/H type) Compatible with Mitsubishi Electric's servo system controller network	<input type="checkbox"/>	<input type="checkbox"/>	<input type="checkbox"/>			SSCNET III/H	<input type="checkbox"/>	<input type="checkbox"/>
	 MECHATROLINK-II LECSB-T (Pulse input type/ Positioning type)		<input type="checkbox"/>	<input type="checkbox"/>	<input type="checkbox"/>			MECHATROLINK-II	<input type="checkbox"/>	
		 MECHATROLINK-III LECSB-T (Pulse input type/ Positioning type)	<input type="checkbox"/>	<input type="checkbox"/>	<input type="checkbox"/>			MECHATROLINK-III	<input type="checkbox"/>	
 LECYU	<input type="checkbox"/>		<input type="checkbox"/>	<input type="checkbox"/>						

*1 For positioning types, the settings need to be changed in order to use the max. set values. Setup software (MR Configurator2™) LEC-MRC2 is required.

*2 Available when a Mitsubishi motion controller is used as the master

*3 Available when a motion controller is used as the master

*4 The LECSB2-T is only applicable when the control method is positioning. The point table is used to set the pushing operation settings. To set the pushing operation settings, an additional dedicated file (pushing operation extension file) must be downloaded separately to be used with the setup software (MR Configurator2™: LEC-MRC2□). Please download this dedicated file from the SMC website: <https://www.smcworld.com/>
 When selecting the LECSS or LECSS2-T, combine it with a master station (such as the Simple Motion module manufactured by Mitsubishi Electric Corporation) which has a pushing operation function.

* For customer-provided PLC and motion controller setting and usage instructions, confirm with the retailer or manufacturer.

Gain adjustment using auto tuning

Auto-tuning function

- Controls the difference between the command value and the actual action

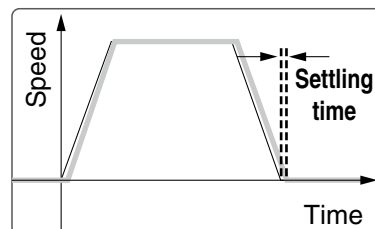
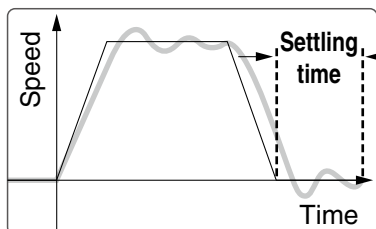

Vibration suppression control function

- Automatically suppresses low-frequency machine vibrations (1 to 100 Hz)

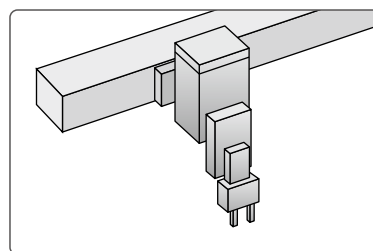
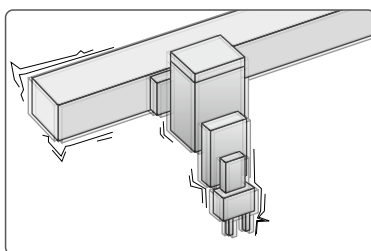

AC Servo Motor Driver

With display setting function

One-touch adjustment button

One-touch servo adjustment

Display

Display the monitor, parameters, and alarm.

Settings

Set the parameters, monitor display, etc., with push buttons.

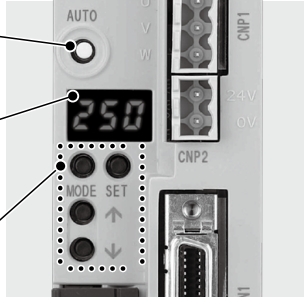

LECSA

Display

Display the monitor, parameters, and alarm.

Settings

Set the parameters, monitor display, etc., with push buttons.

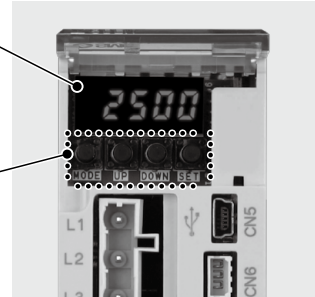

(With the front cover opened)

LECSB

Display

Display the communication status with the driver, the alarm, and the point table no.

Settings

Control the Baud rate, station number, and the occupied station count.

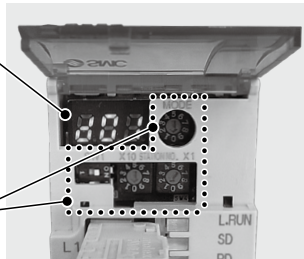

(With the front cover opened)

LECS C

Display

Display the communication status with the driver and the alarm.

Settings

Switches for selecting the axis and switching to the test operation

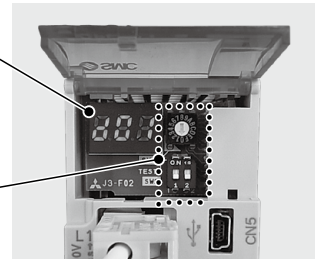

(With the front cover opened)

LECSS

Display

Display the monitor, parameters, and alarm.

Settings

Set the parameters, monitor display, etc., with push buttons.

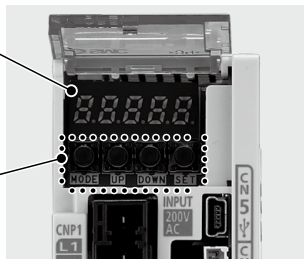

(With the front cover opened)

LECSB-T

Display

Display the communication status with the driver, the alarm, and the point table no.

Settings

Control the Baud rate, station number, and the occupied station count.

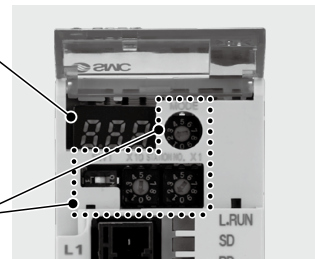

(With the front cover opened)

LECS C-T

Display

Display the communication status with the driver and the alarm.

Settings

Switches for axis setting, control axis deactivation, switching to the test operation, etc.

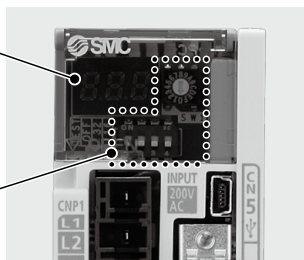

LECSS2-T

Settings

Switches for station address, communication speed, number of transmission bytes, etc.

Display

Display the driver status and alarm.

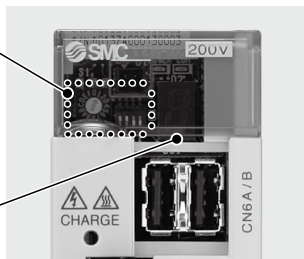

LECYM

Settings

Switches for station address, number of transmission bytes, etc.

Display

Display the driver status and alarm.

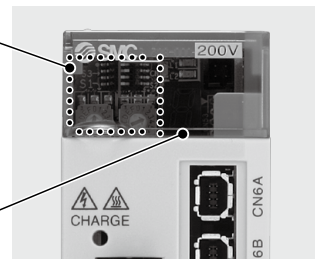

LECYU

System Construction

Incremental encoder compatible **LECSA Series** (Pulse input type/Positioning type)

Provided by the customer

Power supply

Single phase 100 to 120 VAC (50/60 Hz)
200 to 230 VAC (50/60 Hz)

Option

Regeneration option

Part no.: **LEC-MR-RB**

Motor cable

Standard cable	Robotic cable
LE-CSM-S	LE-CSM-R

Lock cable

Standard cable	Robotic cable
LE-CSB-S	LE-CSB-R

Provided by the customer

Power supply for lock
24 VDC

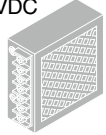

Electric actuator

Slider type
LEF Series

High rigidity slider type
LEJ Series

Rod type
LEY Series

Guide rod type
LEYG Series



Encoder cable

Standard cable	Robotic cable
LE-CSE-S	LE-CSE-R

Provided by the customer

Control circuit power supply
24 VDC



Control circuit power supply connector
(Accessory)



Option

Setup software

(MR Configurator2™)

Part no.: **LEC-MRC2**

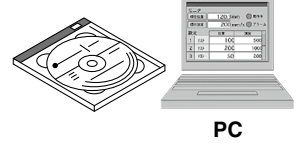

USB cable
Part no.: **LEC-MR-J3USB**

Option

I/O connector
Part no.: **LE-CSNA**
or
I/O cable
Part no.: **LEC-CSNA-1**

Provided by the customer

PLC (Positioning unit)

Power supply for I/O signal
24 VDC

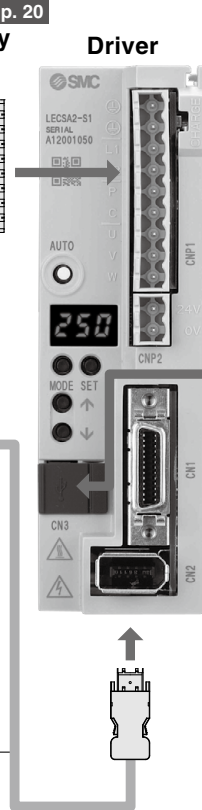
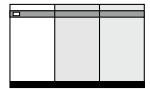

Absolute encoder compatible **LECSB Series** (Pulse input type)

Provided by the customer

Power supply

Single phase 100 to 120 VAC (50/60 Hz)
200 to 230 VAC (50/60 Hz)

Three phase 200 to 230 VAC (50/60 Hz)

Option

Regeneration option

Part no.: **LEC-MR-RB**

Motor cable

Standard cable	Robotic cable
LE-CSM-S	LE-CSM-R

Lock cable

Standard cable	Robotic cable
LE-CSB-S	LE-CSB-R

Provided by the customer

Power supply for lock
24 VDC



Electric actuator

Slider type
LEF Series

High rigidity slider type
LEJ Series

Rod type
LEY Series

Guide rod type
LEYG Series



Encoder cable

Standard cable	Robotic cable
LE-CSE-S	LE-CSE-R

Driver

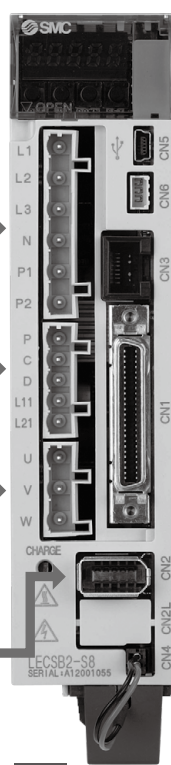

USB cable
Part no.: **LEC-MR-J3USB**

Part no.: **LEC-MR-J3USB**

Option

Setup software

(MR Configurator2™)

Part no.: **LEC-MRC2**

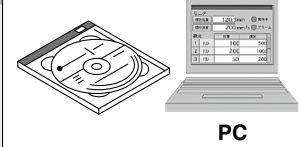

Analog monitor output

RS-422 communication

Control circuit power supply connector
(Accessory)

Motor connector
(Accessory)

Option

I/O connector
Part no.: **LE-CSNB**
or
I/O cable
Part no.: **LEC-CSNB-1**

Provided by the customer

PLC (Positioning unit)

Power supply for I/O signal
24 VDC

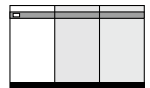

Battery (Accessory)
Part no.: **(LEC-MR-J3BAT)**

System Construction

Absolute encoder compatible **LECS** Series (CC-Link direct input type)

Provided by the customer

Power supply

Single phase 100 to 120 VAC (50/60 Hz)
200 to 230 VAC (50/60 Hz)
Three phase 200 to 230 VAC (50/60 Hz)

Option p. 34
Regeneration option
Part no.: **LEC-MR-RB**

Motor cable p. 32

Standard cable	Robotic cable
LE-CSM-S	LE-CSM-R

Lock cable p. 32

Standard cable	Robotic cable
LE-CSB-S	LE-CSB-R

Provided by the customer

Power supply for lock

24 VDC



Electric actuator

Slider type
LEF Series



High rigidity slider type
LEJ Series

Rod type
LEY Series

Guide rod type
LEYG Series

Encoder cable p. 32

Standard cable	Robotic cable
LE-CSE-S	LE-CSE-R

Main circuit p. 21
power supply connector
(Accessory)

Control circuit p. 21
power supply connector
(Accessory)

Motor p. 21
connector
(Accessory)

Battery (Accessory) p. 36
Part no.: **(LEC-MR-J3BAT)**

Driver

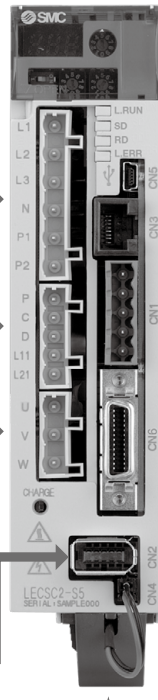

USB cable p. 36
Part no.: **LEC-MR-J3USB**

Option

Setup software p. 35
(MR Configurator2™)
Part no.: **LEC-MRC2**

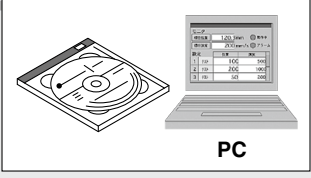

PC

RS-422 communication



CC-Link connector *1
(Accessory)

Option p. 32
I/O connector
Part no.: **LE-CSNA**

or
I/O cable p. 33
Part no.: **LEC-CSNA-1**

Provided by the customer

PLC (CC-Link master unit)

Power supply for I/O signal
24 VDC

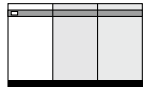

*1 Product number: K05A50230600 manufactured by Mitsubishi Electric System & Service Co., Ltd.

Absolute encoder compatible **LEC**SS Series (SSCNET III type)

Provided by the customer

Power supply

Single phase 100 to 120 VAC (50/60 Hz)
200 to 230 VAC (50/60 Hz)
Three phase 200 to 230 VAC (50/60 Hz)

Option p. 34
Regeneration option
Part no.: **LEC-MR-RB**

Motor cable p. 32

Standard cable	Robotic cable
LE-CSM-S	LE-CSM-R

Lock cable p. 32

Standard cable	Robotic cable
LE-CSB-S	LE-CSB-R

Provided by the customer

Power supply for lock

24 VDC



Electric actuator

Slider type
LEF Series



High rigidity slider type
LEJ Series

Rod type
LEY Series

Guide rod type
LEYG Series

Encoder cable p. 32

Standard cable	Robotic cable
LE-CSE-S	LE-CSE-R

Main circuit p. 21
power supply connector
(Accessory)

Control circuit p. 21
power supply connector
(Accessory)

Motor p. 21
connector
(Accessory)

Battery (Accessory) p. 36
Part no.: **(LEC-MR-J3BAT)**

Driver

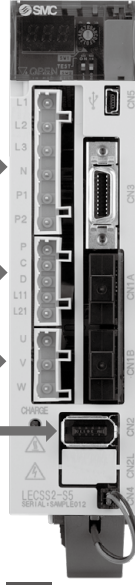

USB cable p. 36
Part no.: **LEC-MR-J3USB**

Option

Setup software p. 35
(MR Configurator2™)
Part no.: **LEC-MRC2**



PC

Option p. 32
I/O connector
Part no.: **LE-CSNS**
or
I/O cable p. 33
Part no.: **LEC-CSNS-1**

Option p. 33
SSCNET III optical cable
Part no.: **LE-CSS**

Option p. 33
SSCNET III optical cable
Part no.: **LE-CSS**

Option p. 33
SSCNET III optical cable
Part no.: **LE-CSS**

Provided by the customer

PLC (Positioning unit/
Motion controller)

Power supply for I/O signal
24 VDC

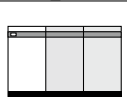

System Construction

Absolute encoder compatible **LECSB-T Series** (Pulse input type/Positioning type)

Provided by the customer

Power supply

Single phase 200 to 240 VAC (50/60 Hz)
Three phase 200 to 240 VAC (50/60 Hz)

Option

Regeneration option p. 34
Part no.: **LEC-MR-RB-**□

Motor cable p. 32

Standard cable	Robotic cable
LE-CSM-S□□	LE-CSM-R□□

Lock cable p. 32

Standard cable	Robotic cable
LE-CSB-S□□	LE-CSB-R□□

Provided by the customer

Power supply for lock
24 VDC

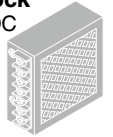

Electric actuator

Slider type
LEF Series

High rigidity slider type
LEJ Series

Rod type
LEY Series

Guide rod type
LEYG Series



Encoder cable p. 32

Standard cable	Robotic cable
LE-CSE-S□□	LE-CSE-R□□

Main circuit power supply connector (Accessory) p. 22

Control circuit power supply connector (Accessory) p. 22

Motor connector (Accessory) p. 22

Battery (Accessory) p. 36
Part no.: **(LEC-MR-BAT6V1SET)**

Driver

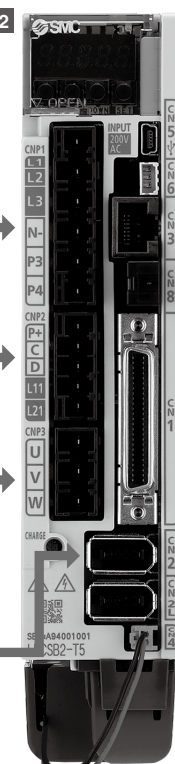

USB cable p. 36

Part no.: **LEC-MR-J3USB**

Option

Setup software p. 35

(MR Configurator2™)
Part no.: **LEC-MRC2**□

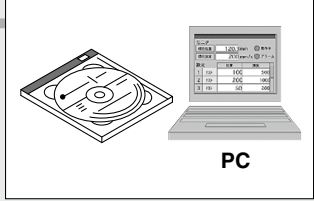

Analog monitor output
RS-422 communication

Option

STO cable (3 m) p. 36
Part no.: **LEC-MR-D05UDL3M**

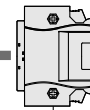

Option

I/O connector p. 32
Part no.: **LE-CSNB**

or
I/O cable p. 33
Part no.: **LEC-CSNB-1**

Provided by the customer

PLC (Positioning unit)

Power supply for I/O signal
24 VDC

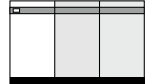

* The LECSB2-T□ cannot be used with the LEC-MR-SETUP221□.

Absolute encoder compatible **LECSC-T Series** (CC-Link direct input type)

Provided by the customer

Power supply

Single phase 200 to 230 VAC (50/60 Hz)
Three phase 200 to 230 VAC (50/60 Hz)

Option

Regeneration option p. 34
Part no.: **LEC-MR-RB-**□

Motor cable p. 32

Standard cable	Robotic cable
LE-CSM-S□□	LE-CSM-R□□

Lock cable p. 32

Standard cable	Robotic cable
LE-CSB-S□□	LE-CSB-R□□

Provided by the customer

Power supply for lock
24 VDC

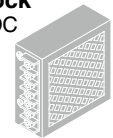

Electric actuator

Slider type
LEF Series

High rigidity slider type
LEJ Series

Rod type
LEY Series

Guide rod type
LEYG Series



Main circuit power supply connector (Accessory) p. 23

Control circuit power supply connector (Accessory) p. 23

Motor connector (Accessory) p. 23

Battery (Accessory) p. 36
Part no.: **(LEC-MR-J3BAT)**

Driver

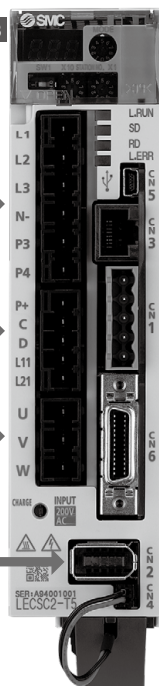

USB cable p. 36

Part no.: **LEC-MR-J3USB**

Option

Setup software p. 35

(MR Configurator2™)
Part no.: **LEC-MRC2**□

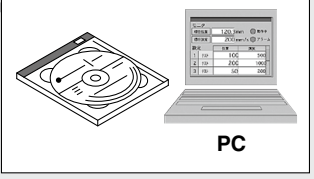

RS-422 communication

CC-Link connector*1 (Accessory)

Option

I/O connector p. 32
Part no.: **LE-CSNA**

or
I/O cable p. 33
Part no.: **LEC-CSNA-1**

Provided by the customer

PLC (CC-Link master unit)

Power supply for I/O signal
24 VDC



* The LECSC2-T□ cannot be used with the LEC-MR-SETUP221□.

*1 Product number: K05A50230600 manufactured by Mitsubishi Electric System & Service Co., Ltd.

System Construction

Absolute encoder compatible **LECSS-T Series**



Provided by the customer

Power supply
Single phase 200 to 240 VAC (50/60 Hz)
Three phase 200 to 240 VAC (50/60 Hz)

◎Option p. 34
Regeneration option
Part no.: LEC-MR-RB-□

●Motor cable p. 32
Standard cable Robotic cable
LE-CSM-S□□ LE-CSM-R□□

●Lock cable p. 32
Standard cable Robotic cable
LE-CSB-S□□ LE-CSB-R□□

Provided by the customer

Power supply for lock
24 VDC



Electric actuator

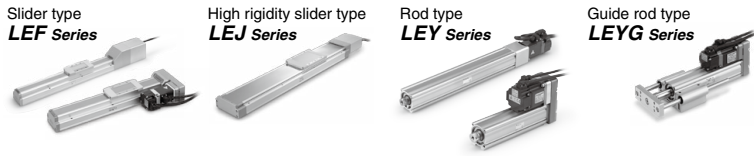

* The LECSS2-T□ cannot be used with the LEC-MR-SETUP221□.

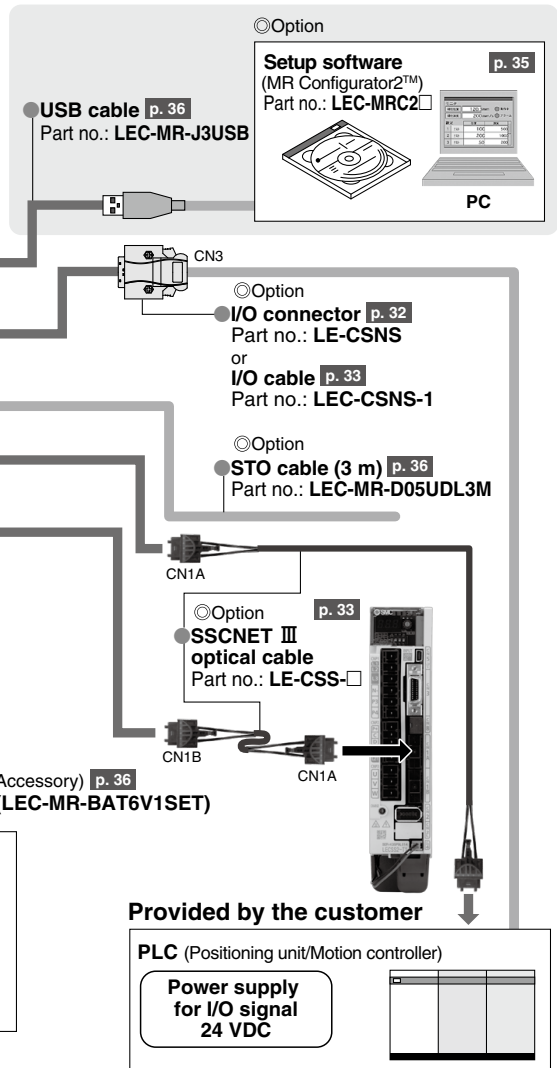
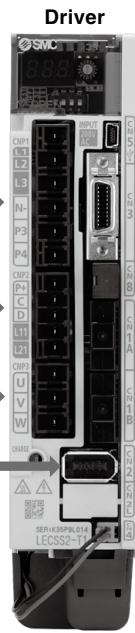

System Construction

Absolute encoder compatible **LECYM Series** MECHATROLINK-II type

Provided by the customer

Power supply

Single phase 200 to 230 VAC (50/60 Hz)
Three phase 200 to 230 VAC (50/60 Hz)

Provided by the customer

External regenerative resistor

p. 40

* If an external regenerative resistor is required, it should be provided by the customer. For external regenerative resistor selection, refer to the compatible actuator catalog.

Motor cable

p. 43

Standard cable	Robotic cable
LE-CYM-S□A-□	LE-CYM-R□A-□

Motor cable for lock option

p. 43

Standard cable	Robotic cable
LE-CYB-S□A-□	LE-CYB-R□A-□

Provided by the customer

Power supply for lock
24 VDC



Electric actuator

Slider type
LEF Series



High rigidity slider type
LEJ Series

Rod type
LEY/LEYG Series

Main circuit power supply connector (Accessory)

p. 40

Motor connector (Accessory)

Encoder cable

p. 43

Standard cable	Robotic cable
LE-CYE-S□A	LE-CYE-R□A

Driver



Option

MECHATROLINK-II cable p. 45
Part no.: LEC-CYM-□

2nd driver

Provided by the customer

PLC (Positioning unit/Motion controller)

Power supply for I/O signal
24 VDC

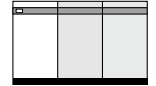

Option

USB cable p. 46
Part no.: LEC-JZ-CVUSB

Setup software

p. 46

(SigmaWin+™)

Please download it via our website.



PC

* Order the USB cable (Part no.: LEC-JZ-CVUSB) separately to use this software.

Option

I/O p. 44
connector
Part no.: LE-CYNA
or
I/O cable p. 44
Part no.: LEC-CSNA-1

Cable for safety function device (3 m) p. 46
Part no.: LEC-JZ-CVSAF

Absolute encoder compatible **LECYU Series** MECHATROLINK-III type

Provided by the customer

Power supply

Single phase 200 to 230 VAC (50/60 Hz)
Three phase 200 to 230 VAC (50/60 Hz)

Provided by the customer

External regenerative resistor

p. 40

* If an external regenerative resistor is required, it should be provided by the customer. For external regenerative resistor selection, refer to the compatible actuator catalog.

Motor cable

p. 43

Standard cable	Robotic cable
LE-CYM-S□A-□	LE-CYM-R□A-□

Motor cable for lock option

p. 43

Standard cable	Robotic cable
LE-CYB-S□A-□	LE-CYB-R□A-□

Provided by the customer

Power supply for lock
24 VDC



Electric actuator

Slider type
LEF Series



High rigidity slider type
LEJ Series

Rod type
LEY/LEYG Series

Main circuit power supply connector (Accessory)

p. 40

Motor connector (Accessory)

Encoder cable

p. 43

Standard cable	Robotic cable
LE-CYE-S□A	LE-CYE-R□A

Driver



Option

MECHATROLINK-III cable p. 45
Part no.: LEC-CYU-□

2nd driver

Provided by the customer

PLC (Positioning unit/Motion controller)

Power supply for I/O signal
24 VDC



Option

USB cable p. 46
Part no.: LEC-JZ-CVUSB

Setup software

p. 46

(SigmaWin+™)

Please download it via our website.



PC

* Order the USB cable (Part no.: LEC-JZ-CVUSB) separately to use this software.

Option

I/O p. 44
connector
Part no.: LE-CYNA
or
I/O cable p. 44
Part no.: LEC-CSNA-1

Cable for safety function device (3 m) p. 46
Part no.: LEC-JZ-CVSAF

AC Servo Motor Driver

LECS□ Series

Power supply voltage 100 to 120 VAC
200 to 230 VAC

Motor capacity 100/200/400 W

Incremental Type

LECSA Series (Pulse input type/ Positioning type)



- Up to 7 positioning points by point table
- Input type: Pulse input
- Control encoder: Incremental 17-bit encoder (Resolution: 131,072 p/rev)
- Parallel input: 6 inputs
output: 4 outputs

LECSB Series (Pulse input type)



- Input type: Pulse input
- Control encoder: Absolute 18-bit encoder (Resolution: 262,144 p/rev)
- Parallel input: 10 inputs
output: 6 outputs

LECS C Series (CC-Link direct input type)



- Position data/speed data setting and operation start/stop
- Positioning by up to 255 point tables (when 2 stations are occupied)
- Up to 32 drivers can be connected (when 2 stations are occupied) with CC-Link communication.
- Applicable Fieldbus protocol: CC-Link (Ver. 1.10, Max. communication speed: 10 Mbps)
- Control encoder: Absolute 18-bit encoder (Resolution: 262,144 p/rev)

CC-Link

LECSS Series (SSCNET III type)



- Compatible with Mitsubishi Electric's servo system controller network
- Reduced wiring and SSCNET III optical cable for one-touch connection
- The SSCNET III optical cable provides enhanced noise resistance.
- Up to 16 drivers can be connected with SSCNET III communication.
- Applicable Fieldbus protocol: SSCNET III
(High-speed optical communication, Max. bidirectional communication speed: 50 Mbps)
- Control encoder: Absolute 18-bit encoder (Resolution: 262,144 p/rev)

SSCNET III
SERVO SYSTEM CONTROLLER NETWORK

AC Servo Motor Driver

LECS□-T Series

Power supply voltage 200 to 240 VAC
(LECS-C-T Series: 200 to 230 VAC)

Motor capacity 100/200/400 W

Absolute Type

LECSB-T Series (Pulse input type/Positioning type)



- Positioning by up to 255 point tables
- Input type: Pulse input (Sink (NPN) type interface/Source (PNP) type interface)
- Control encoder: Absolute 22-bit encoder (Resolution: 4,194,304 p/rev)
- STO (Safe Torque Off) safety function available
- Parallel input: 10 inputs
output: 6 outputs

LECS-C-T Series (CC-Link direct input type)



- Position data/speed data setting and operation start/stop
- Positioning by up to 255 point tables (when 2 stations are occupied)
- Up to 32 drivers can be connected (when 2 stations are occupied) with CC-Link communication.
- Applicable Fieldbus protocol: CC-Link (Ver. 1.10, Max. communication speed: 10 Mbps)
- Control encoder: Absolute 18-bit encoder (Resolution: 262,144 p/rev)

CC-Link

LECSS-T Series (SSCNET III/H type)



- Applicable Fieldbus protocol: 
(High-speed optical communication, max. bidirectional communication speed: 150 Mbps)
- Bidirectional communication speed: 3 times
- SSCNET III/H and SSCNET III products are compatible.
- Improved noise resistance
- STO (Safe Torque Off) safety function available
- Control encoder: Absolute 22-bit encoder (Resolution: 4,194,304 p/rev)

SERVO SYSTEM CONTROLLER NETWORK

AC Servo Motor Driver

LECY□ Series

Power supply voltage 200 to 230 VAC

Motor capacity 100/200/400 W

Absolute Type

LECYM Series (MECHATROLINK-II type)



 MECHATROLINK-II

- **Applicable Fieldbus protocol:**  MECHATROLINK-II
- **Number of connectable drivers:** 30 units (Transmission distance: Max. 50 m in total)
- **Max. transmission speed:** 10 Mbps
- **Min. transmission cycle:** 250 μ s
- **Control encoder:** Absolute 20-bit encoder (Resolution: 1,048,576 p/rev)
- **STO (Safe Torque Off) safety function available**
- **Compliant with the SEMI F47 Standard (Torque limit for low DC power supply voltage for main circuit)**

LECYU Series (MECHATROLINK-III type)



 MECHATROLINK-III

- **Applicable Fieldbus protocol:**  MECHATROLINK-III
- **Number of connectable drivers:** 62 units (Transmission distance: Max. 75 m between stations)
- **Max. transmission speed:** 100 Mbps
- **Min. transmission cycle:** 125 μ s
- **Control encoder:** Absolute 20-bit encoder (Resolution: 1,048,576 p/rev)
- **STO (Safe Torque Off) safety function available**
- **Compliant with the SEMI F47 Standard (Torque limit for low DC power supply voltage for main circuit)**

CONTENTS

AC Servo Motor Driver



LECSA LECSB LECS LECS



LECSB-T LECS-T LECS-T



LECYM LECYU

Incremental Type / Absolute Type LECS□/LECS□-T Series

How to Order	p. 13
Dimensions	p. 14
Specifications	p. 16
Power Supply Wiring Example	p. 20
Control Signal Wiring Example	p. 24
Options	p. 32

MECHATROLINK Compatible Absolute Type LECY□ Series

How to Order	p. 37
Dimensions	p. 37
Specifications	p. 38
Power Supply Wiring Example	p. 40
Control Signal Wiring Example	p. 41
Options	p. 43

Specific Product Precautions	p. 47
------------------------------------	-------

LECS□/LECS□-T Series

LECY□ Series

Specific Product Precautions

AC Servo Motor Driver

Incremental Type

LECSA Series (Pulse Input Type/Positioning Type)

Absolute Type

LECSB (Pulse Input Type)/**LECSC** (CC-Link Direct Input Type)/**LECSS** (SSCNET III Type)

LECSB-T (Pulse Input Type/Positioning Type)/**LECSC-T** (CC-Link Direct Input Type)

LECSS-T (SSCNET III/H Type) **Series**



* LECSS-T only

How to Order

For LECSA/LECSB/LECSC/LECSS

LECS A 1 - S1

Driver type

A	Pulse input type/Positioning type (For incremental encoder)
B	Pulse input type (For absolute encoder)
C	CC-Link direct input type (For absolute encoder)
S	SSCNET III type (For absolute encoder)

Power supply voltage

1	100 to 120 VAC, 50/60 Hz
2	200 to 230 VAC, 50/60 Hz

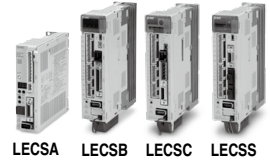

- * If an I/O connector is required, order the part number "LE-CSN□" separately.
- * If an I/O cable is required, order the part number "LEC-CSN□-1" separately.
(Since the electric actuator will not operate without emergency stop (EMG) wiring for the LECSB, an I/O connector or an I/O cable is required.)

Compatible motor type

Symbol	Type	Capacity	Encoder
S1	AC servo motor (S2*1)	100 W	Incremental
S3	AC servo motor (S3*1)	200 W	
S4	AC servo motor (S4*1)*2	400 W	
S5	AC servo motor (S6*1)	100 W	Absolute
S7	AC servo motor (S7*1)	200 W	
S8	AC servo motor (S8*1)*2	400 W	

*1 The symbol shows the motor type (actuator).

*2 Only available for power supply voltage "200 to 230 VAC"

For LECSB-T/LECSC-T/LECSS-T

LECS B 2 - T5

Driver type

B	Pulse input type/Positioning type (For absolute encoder)
C	CC-Link direct input type (For absolute encoder)
S	SSCNET III/H type (For absolute encoder)

Power supply voltage

2	200 to 240 VAC, 50/60 Hz (For LECSB2-T/LECSS2-T)
	200 to 230 VAC, 50/60 Hz (For LECSC2-T)



- * If an I/O connector is required, order the part number "LE-CSN□" separately.
- * If an I/O cable is required, order the part number "LEC-CSN□-1" separately.
(Since the electric actuator will not operate without forced stop (EM2) wiring when using the LECSB-T in any mode other than positioning mode, an I/O connector or an I/O cable is required.)

Compatible motor type

Symbol	Type	Capacity	Encoder
T5	AC servo motor (T6*1)	100 W	Absolute
T7	AC servo motor (T7*1)	200 W	
T8	AC servo motor (T8*1)	400 W	

*1 The symbol shows the motor type (actuator).

Dimensions

LECSA□

For LECSA□-S1, S3

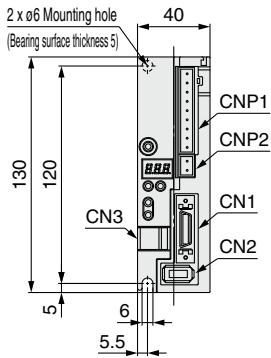

For LECSA□-S4

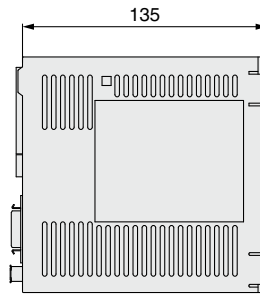
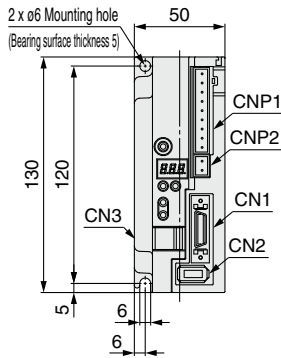

Connector name	Description
CN1	I/O signal connector
CN2	Encoder connector
CN3	USB communication connector
CNP1	Main circuit power supply connector
CNP2	Control circuit power supply connector

LECSB□

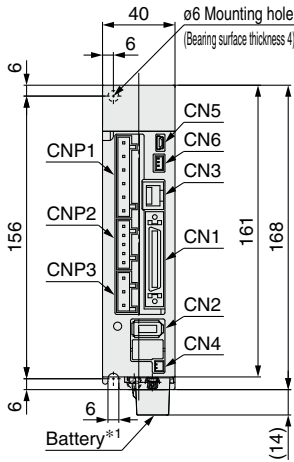

*1 Battery included

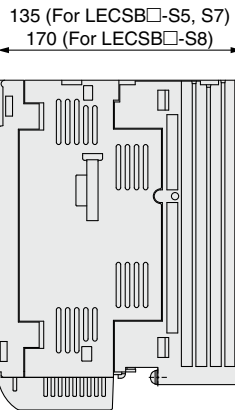

Connector name	Description
CN1	I/O signal connector
CN2	Encoder connector
CN3	RS-422 communication connector
CN4	Battery connector
CN5	USB communication connector
CN6	Analog monitor connector
CNP1	Main circuit power supply connector
CNP2	Control circuit power supply connector
CNP3	Servo motor power connector

LECS□

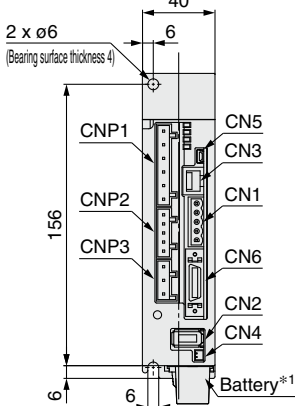

*1 Battery included

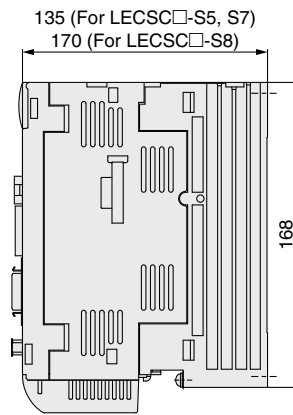

Connector name	Description
CN1	CC-Link connector
CN2	Encoder connector
CN3	RS-422 communication connector
CN4	Battery connector
CN5	USB communication connector
CN6	I/O signal connector
CNP1	Main circuit power supply connector
CNP2	Control circuit power supply connector
CNP3	Servo motor power connector

LECS□

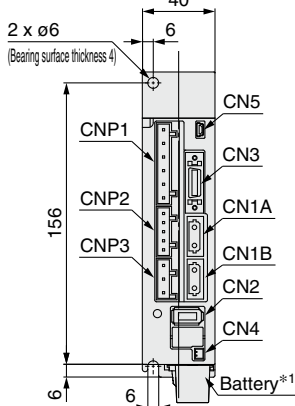

*1 Battery included

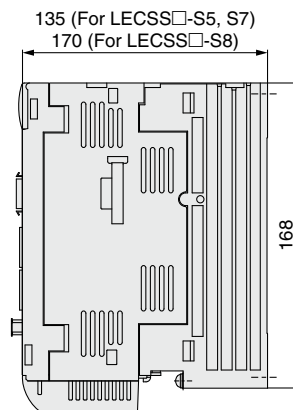

Connector name	Description
CN1A	Front axis connector for SSCNET III optical cable
CN1B	Rear axis connector for SSCNET III optical cable
CN2	Encoder connector
CN3	I/O signal connector
CN4	Battery connector
CN5	USB communication connector
CNP1	Main circuit power supply connector
CNP2	Control circuit power supply connector
CNP3	Servo motor power connector

LECS□/LECS□-T Series

LECY□ Series

Specific Product Precautions

LECS□/LECS□-T Series

Dimensions

LECSB2-T□

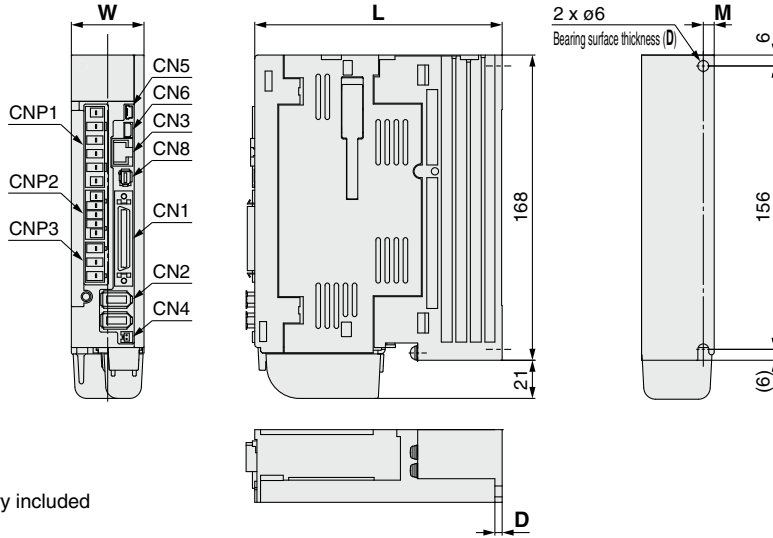

* Battery included

Connector name	Description
CN1	I/O signal connector
CN2	Encoder connector
CN3	RS-422 communication connector
CN4	Battery connector
CN5	USB communication connector
CN6	Analog monitor connector
CN8	STO input signal connector
CNP1	Main circuit power supply connector
CNP2	Control circuit power supply connector
CNP3	Servo motor power connector

Dimensions [mm]

Model	W	L	D	M
LECSB2-T5	40	135	4	6
LECSB2-T7		170	5	
LECSB2-T8				

LECS2-T□

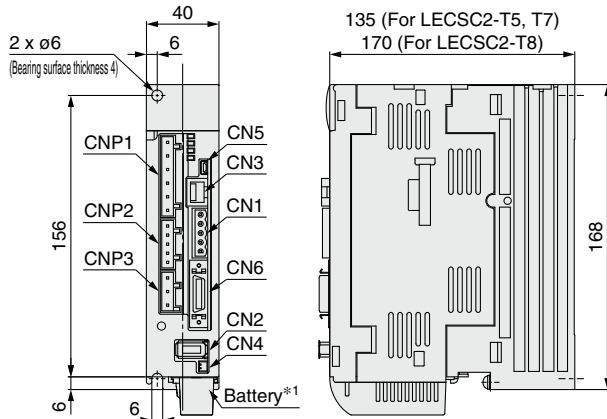

*1 Battery included

Connector name	Description
CN1	CC-Link connector
CN2	Encoder connector
CN3	RS-422 communication connector
CN4	Battery connector
CN5	USB communication connector
CN6	I/O signal connector
CNP1	Main circuit power supply connector
CNP2	Control circuit power supply connector
CNP3	Servo motor power connector

LECSS2-T□

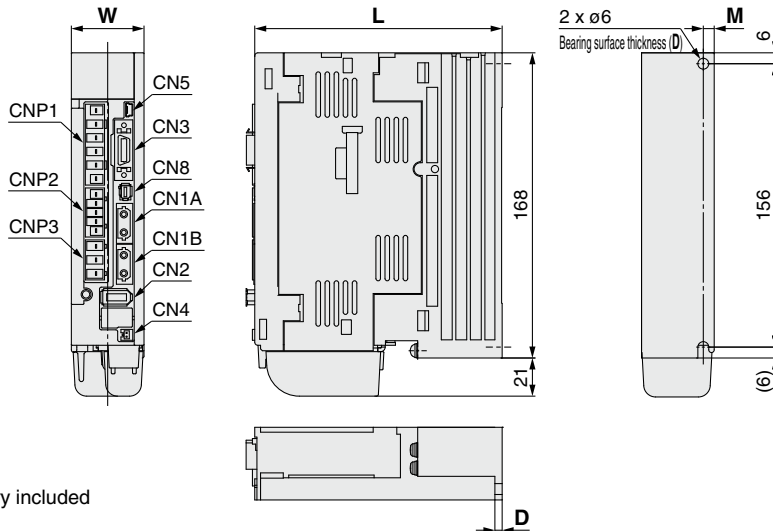

* Battery included

Connector name	Description
CN1A	Front axis connector for SSCNET III/H
CN1B	Rear axis connector for SSCNET III/H
CN2	Encoder connector
CN3	I/O signal connector
CN4	Battery connector
CN5	USB communication connector
CN8	STO input signal connector
CNP1	Main circuit power supply connector
CNP2	Control circuit power supply connector
CNP3	Servo motor power connector

Dimensions [mm]

Model	W	L	D	M
LECSS2-T5	40	135	4	6
LECSS2-T7		170	5	
LECSS2-T8				

Specifications

LECSA Series

Model		LECSA1-S1	LECSA1-S3	LECSA2-S1	LECSA2-S3	LECSA2-S4
Compatible motor capacity [W]		100	200	100	200	400
Compatible encoder		Incremental 17-bit encoder (Resolution: 131,072 p/rev)				
Main power supply	Power voltage [V]	Single phase 100 to 120 VAC (50/60 Hz)		Single phase 200 to 230 VAC (50/60 Hz)		
	Allowable voltage fluctuation [V]	Single phase 85 to 132 VAC		Single phase 170 to 253 VAC		
	Rated current [A]	3.0	5.0	1.5	2.4	4.5
Control power supply	Control power supply voltage [V]	24 VDC				
	Allowable voltage fluctuation [V]	21.6 to 26.4 VDC				
	Rated current [A]	0.5				
Parallel input		6 inputs				
Parallel output		4 outputs				
Max. input pulse frequency [pps]		1 M (for differential receiver), 200 k (for open collector)*2				
Function	In-position range setting [pulse]	0 to ±65535 (Command pulse unit)				
	Error excessive	±3 rotations				
	Torque limit	Parameter setting				
	Communication	USB communication				
Point table		Up to 7 points				
Operating temperature range [°C]		0 to 55 (No freezing)				
Operating humidity range [%RH]		90 or less (No condensation)				
Storage temperature range [°C]		-20 to 65 (No freezing)				
Storage humidity range [%RH]		90 or less (No condensation)				
Insulation resistance [MΩ]		Between the housing and SG: 10 (500 VDC)				
Weight [g]		600				700

LECSB Series

Model		LECSB1-S5	LECSB1-S7	LECSB2-S5	LECSB2-S7	LECSB2-S8
Compatible motor capacity [W]		100	200	100	200	400
Compatible encoder		Absolute 18-bit encoder (Resolution: 262,144 p/rev)				
Main power supply	Power voltage [V]	Single phase 100 to 120 VAC (50/60 Hz)		Three phase 200 to 230 VAC (50/60 Hz) Single phase 200 to 230 VAC (50/60 Hz)		
	Allowable voltage fluctuation [V]	Single phase 85 to 132 VAC		Three phase 170 to 253 VAC Single phase 170 to 253 VAC		
	Rated current [A]	3.0	5.0	0.9	1.5	2.6
Control power supply	Control power supply voltage [V]	Single phase 100 to 120 VAC (50/60 Hz)		Single phase 200 to 230 VAC (50/60 Hz)		
	Allowable voltage fluctuation [V]	Single phase 85 to 132 VAC		Single phase 170 to 253 VAC		
	Rated current [A]	0.4		0.2		
Parallel input		10 inputs				
Parallel output		6 outputs				
Max. input pulse frequency [pps]		1 M (for differential receiver), 200 k (for open collector)*2				
Function	In-position range setting [pulse]	0 to ±10000 (Command pulse unit)				
	Error excessive	±3 rotations				
	Torque limit	Parameter setting or external analog input setting (0 to 10 VDC)				
	Communication	USB communication, RS422 communication*1				
Operating temperature range [°C]		0 to 55 (No freezing)				
Operating humidity range [%RH]		90 or less (No condensation)				
Storage temperature range [°C]		-20 to 65 (No freezing)				
Storage humidity range [%RH]		90 or less (No condensation)				
Insulation resistance [MΩ]		Between the housing and SG: 10 (500 VDC)				
Weight [g]		800				1000

*1 USB communication and RS422 communication cannot be performed at the same time.

*2 If the command pulse train input is open collector method, it supports only the sink (NPN) type interface. It does not correspond to the source (PNP) type interface.

LECS□/LECS□-T Series

Specifications

LECSC Series

Model		LECSC1-S5	LECSC1-S7	LECSC2-S5	LECSC2-S7	LECSC2-S8
Compatible motor capacity [W]		100	200	100	200	400
Compatible encoder		Absolute 18-bit encoder (Resolution: 262,144 p/rev)				
Main power supply	Power voltage [V]	Single phase 100 to 120 VAC (50/60 Hz)		Three phase 200 to 230 VAC (50/60 Hz) Single phase 200 to 230 VAC (50/60 Hz)		
	Allowable voltage fluctuation [V]	Single phase 85 to 132 VAC		Three phase 170 to 253 VAC Single phase 170 to 253 VAC		
	Rated current [A]	3.0	5.0	0.9	1.5	2.6
Control power supply	Control power supply voltage [V]	Single phase 100 to 120 VAC (50/60 Hz)		Single phase 200 to 230 VAC (50/60 Hz)		
	Allowable voltage fluctuation [V]	Single phase 85 to 132 VAC		Single phase 170 to 253 VAC		
	Rated current [A]	0.4		0.2		
Communication specifications	Applicable Fieldbus protocol (Version)		CC-Link communication (Ver. 1.10)			
	Connection cable		CC-Link Ver. 1.10 compliant cable (Shielded 3-core twisted pair cable)*1			
	Remote station number		1 to 64			
	Cable length	Communication speed [bps]/ Maximum overall cable length [m]	16 k/1200, 625 k/900, 2.5 M/400, 5 M/160, 10 M/100			
		Cable length between stations [m]	0.2 or more			
	I/O occupation area (Inputs/Outputs)		1 station occupied (Remote I/O 32 points/32 points)/(Remote register 4 words/4 words) 2 stations occupied (Remote I/O 64 points/64 points)/(Remote register 8 words/8 words)			
	Number of connectable drivers		Up to 42 (when 1 station is occupied by 1 driver), Up to 32 (when 2 stations are occupied by 1 driver), when there are only remote device stations.			
Command method	Remote register input		Available with CC-Link communication (2 stations occupied)			
	Point table No. input		Available with CC-Link communication, RS422 communication CC-Link communication (1 station occupied): 31 points CC-Link communication (2 stations occupied): 255 points RS422 communication: 255 points			
	Indexer positioning input		Available with CC-Link communication CC-Link communication (1 station occupied): 31 points CC-Link communication (2 stations occupied): 255 points			
Communication function		USB communication, RS-422 communication*2				
Operating temperature range [°C]		0 to 55 (No freezing)				
Operating humidity range [%RH]		90 or less (No condensation)				
Storage temperature range [°C]		-20 to 65 (No freezing)				
Storage humidity range [%RH]		90 or less (No condensation)				
Insulation resistance [MΩ]		Between the housing and SG: 10 (500 VDC)				
Weight [g]		800			1000	

*1 If the system comprises of both CC-Link Ver. 1.00 and Ver. 1.10 compliant cables, Ver. 1.00 specifications are applied to the overall cable length and the cable length between stations.

*2 USB communication and RS422 communication cannot be performed at the same time.

LECSS Series

Model		LECSS1-S5	LECSS1-S7	LECSS2-S5	LECSS2-S7	LECSS2-S8
Compatible motor capacity [W]		100	200	100	200	400
Compatible encoder		Absolute 18-bit encoder (Resolution: 262,144 p/rev)				
Main power supply	Power voltage [V]	Single phase 100 to 120 VAC (50/60 Hz)		Three phase 200 to 230 VAC (50/60 Hz) Single phase 200 to 230 VAC (50/60 Hz)		
	Allowable voltage fluctuation [V]	Single phase 85 to 132 VAC		Three phase 170 to 253 VAC Single phase 170 to 253 VAC		
	Rated current [A]	3.0	5.0	0.9	1.5	2.6
Control power supply	Control power supply voltage [V]	Single phase 100 to 120 VAC (50/60 Hz)		Single phase 200 to 230 VAC (50/60 Hz)		
	Allowable voltage fluctuation [V]	Single phase 85 to 132 VAC		Single phase 170 to 253 VAC		
	Rated current [A]	0.4		0.2		
Applicable Fieldbus protocol		SSCNET III (High-speed optical communication)				
Communication function		USB communication				
Operating temperature range [°C]		0 to 55 (No freezing)				
Operating humidity range [%RH]		90 or less (No condensation)				
Storage temperature range [°C]		-20 to 65 (No freezing)				
Storage humidity range [%RH]		90 or less (No condensation)				
Insulation resistance [MΩ]		Between the housing and SG: 10 (500 VDC)				
Weight [g]		800			1000	

Specifications

LECSB-T Series

Model		LECSB2-T5	LECSB2-T7	LECSB2-T8
Compatible motor capacity [W]		100	200	400
Compatible encoder		Absolute 22-bit encoder (Resolution: 4,194,304 p/rev)		
Main power supply	Power voltage [V]	Three phase 200 to 240 VAC (50/60 Hz), Single phase 200 to 240 VAC (50/60 Hz)		
	Allowable voltage fluctuation [V]	Three phase 170 to 264 VAC (50/60 Hz), Single phase 170 to 264 VAC (50/60 Hz)		
	Rated current [A]	0.9	1.5	2.6
Control power supply	Control power supply voltage [V]	Single phase 200 to 240 VAC (50/60 Hz)		
	Allowable voltage fluctuation [V]	Single phase 170 to 264 VAC		
	Rated current [A]	0.2		
Parallel input		10 inputs		
Parallel output		6 outputs		
Max. input pulse frequency [pps]		4 M (for differential receiver), 200 k (for open collector)		
Function	In-position range setting [pulse]	0 to ±65535 (Command pulse unit)		
	Error excessive	±3 rotations		
	Torque limit	Parameter setting or external analog input setting (0 to 10 VDC)		
	Communication	USB communication, RS422 communication*1		
	Point table	Up to 255 points		
Pushing operation		Point table no. input method, Up to 127 points		
Operating temperature range [°C]		0 to 55 (No freezing)		
Operating humidity range [%RH]		90 or less (No condensation)		
Storage temperature range [°C]		-20 to 65 (No freezing)		
Storage humidity range [%RH]		90 or less (No condensation)		
Insulation resistance [MΩ]		Between the housing and SG: 10 (500 VDC)		
Weight [g]		800		1000

*1 USB communication and RS422 communication cannot be performed at the same time.

LECSC-T Series

Model		LECSC2-T5	LECSC2-T7	LECSC2-T8
Compatible motor capacity [W]		100	200	400
Compatible encoder		Absolute 18-bit encoder (Resolution: 262,144 p/rev)		
Main power supply	Power voltage [V]	Three phase 200 to 230 VAC (50/60 Hz), Single phase 200 to 230 VAC (50/60 Hz)		
	Allowable voltage fluctuation [V]	Three phase 170 to 253 VAC, Single phase 170 to 253 VAC		
	Rated current [A]	0.9	1.5	2.6
Control power supply	Control power supply voltage [V]	Single phase 200 to 230 VAC (50/60 Hz)		
	Allowable voltage fluctuation [V]	Single phase 170 to 253 VAC		
	Rated current [A]	0.2		
Communication specifications	Applicable Fieldbus protocol (Version)		CC-Link communication (Ver. 1.10)	
	Connection cable		CC-Link Ver. 1.10 compliant cable (Shielded 3-core twisted pair cable)*1	
	Remote station number		1 to 64	
	Cable length	Communication speed [bps]/ Maximum overall cable length [m]	16 k/1200, 625 k/900, 2.5 M/400, 5 M/160, 10 M/100	
		Cable length between stations [m]	0.2 or more	
	I/O occupation area (Inputs/Outputs)		1 station occupied (Remote I/O 32 points/32 points)/(Remote register 4 words/4 words) 2 stations occupied (Remote I/O 64 points/64 points)/(Remote register 8 words/8 words)	
	Number of connectable drivers		Up to 42 (when 1 station is occupied by 1 driver), Up to 32 (when 2 stations are occupied by 1 driver), when there are only remote device stations.	
Command method	Remote register input		Available with CC-Link communication (2 stations occupied)	
	Point table No. input		Available with CC-Link communication, RS422 communication CC-Link communication (1 station occupied): 31 points, CC-Link communication (2 stations occupied): 255 points RS422 communication: 255 points	
	Indexer positioning input		Available with CC-Link communication CC-Link communication (1 station occupied): 31 points, CC-Link communication (2 stations occupied): 255 points	
Communication function		USB communication, RS-422 communication*2		
Operating temperature range [°C]		0 to 55 (No freezing)		
Operating humidity range [%RH]		90 or less (No condensation)		
Storage temperature range [°C]		-20 to 65 (No freezing)		
Storage humidity range [%RH]		90 or less (No condensation)		
Insulation resistance [MΩ]		Between the housing and SG: 10 (500 VDC)		
Weight [g]		800		1000

*1 If the system comprises of both CC-Link Ver. 1.00 and Ver. 1.10 compliant cables, Ver. 1.00 specifications are applied to the overall cable length and the cable length between stations.

*2 USB communication and RS422 communication cannot be performed at the same time.

LECS□/LECS□-T Series

Specifications

LECSS-T Series

Model		LECSS2-T5	LECSS2-T7	LECSS2-T8
Compatible motor capacity [W]		100	200	400
Compatible encoder		Absolute 22-bit encoder (Resolution: 4,194,304 p/rev)		
Main power supply	Power voltage [V]	Three phase 200 to 240 VAC (50/60 Hz), Single phase 200 to 240 VAC (50/60 Hz)		
	Allowable voltage fluctuation [V]	Three phase 170 to 264 VAC (50/60 Hz), Single phase 170 to 264 VAC (50/60 Hz)		
	Rated current [A]	0.9	1.5	2.6
Control power supply	Control power supply voltage [V]	Single phase 200 to 240 VAC (50/60 Hz)		
	Allowable voltage fluctuation [V]	Single phase 170 to 264 VAC		
	Rated current [A]	0.2		
Applicable Fieldbus protocol		SSCNET III/H (High-speed optical communication)		
Communication function		USB communication		
Operating temperature range [°C]		0 to 55 (No freezing)		
Operating humidity range [%RH]		90 or less (No condensation)		
Storage temperature range [°C]		-20 to 65 (No freezing)		
Storage humidity range [%RH]		90 or less (No condensation)		
Insulation resistance [MΩ]		Between the housing and SG: 10 (500 VDC)		
Weight [g]		800		1000

Power Supply Wiring Example: LECSA

LECSA□-□

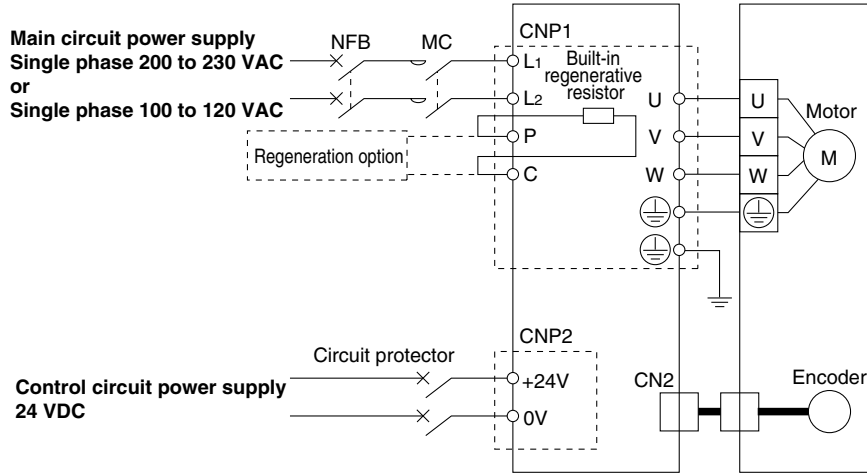

Main Circuit Power Supply Connector: CNP1 * Accessory

Terminal name	Function	Details
	Protective earth (PE)	Should be grounded by connecting the servo motor's earth terminal and the control panel's protective earth (PE)
L1	Main circuit power supply	Connect the main circuit power supply. LECSA1: Single phase 100 to 120 VAC, 50/60 Hz LECSA2: Single phase 200 to 230 VAC, 50/60 Hz
L2		
P	Regeneration option	Terminal to connect regeneration option LECSA□-S1: Not connected at time of shipping LECSA□-S3, S4: Connected at time of shipping * If regeneration option is required for "Model Selection," connect to this terminal.
C		
U	Servo motor power (U)	Connect to motor cable (U, V, W).
V	Servo motor power (V)	
W	Servo motor power (W)	

Control Circuit Power Supply Connector: CNP2 * Accessory

Terminal name	Function	Details
24V	Control circuit power supply (24 V)	24 V side of the control circuit power supply (24 VDC) supplied to the driver
0V	Control circuit power supply (0 V)	0 V side of the control circuit power supply (24 VDC) supplied to the driver

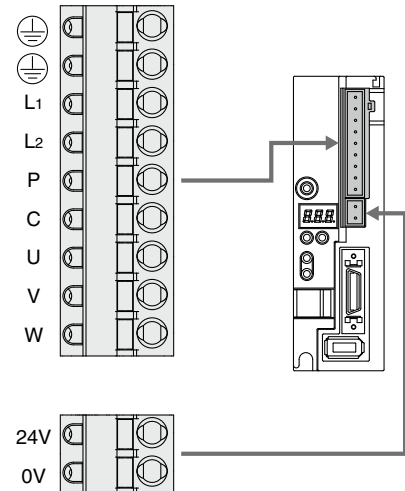

LECS□/LECS□-T Series

Power Supply Wiring Example: LECSB, LECS□, LECS□

LECSB1-□
LECS□1-□
LECS□1-□

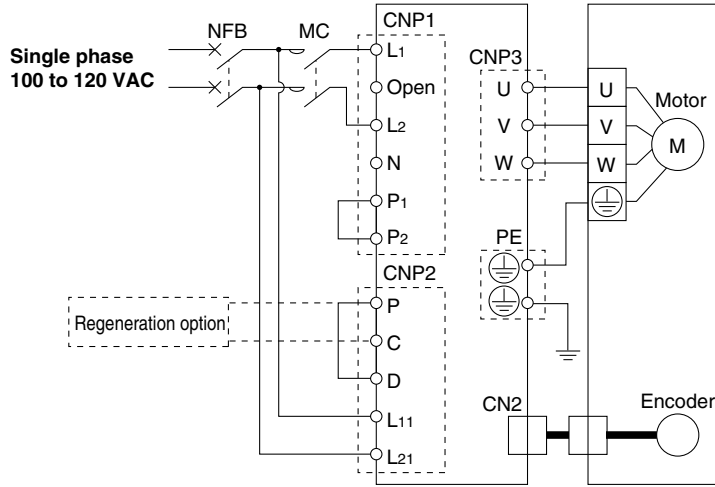

LECSB2-□
LECS□2-□
LECS□2-□

For single phase 200 VAC

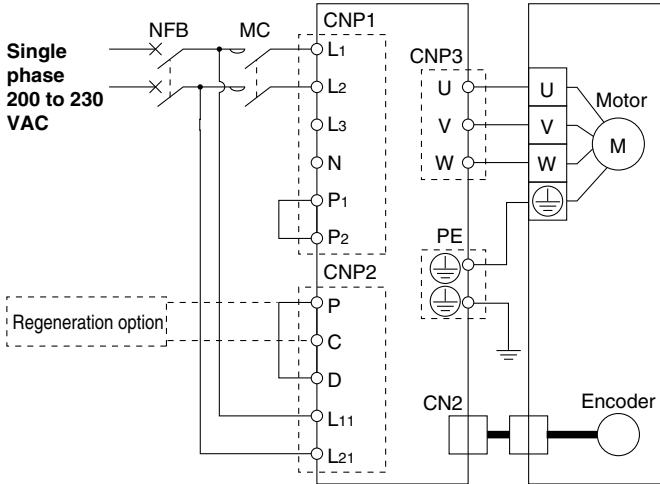

For three phase 200 VAC

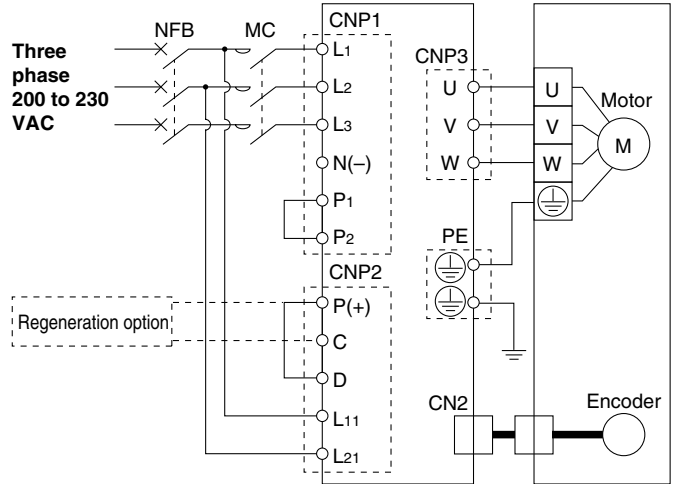

* For single phase 200 to 230 VAC, power supply should be connected to L1 and L2 terminals, with nothing connected to L3.

Main Circuit Power Supply Connector: CNP1 * Accessory

Terminal name	Function	Details
L1	Main circuit power supply	Connect the main circuit power supply. LECSB1/LECS□1/LECS□1: Single phase 100 to 120 VAC, 50/60 Hz Connection terminal: L1, L2 LECSB2/LECS□2/LECS□2: Single phase 200 to 230 VAC, 50/60 Hz Connection terminal: L1, L2 Three phase 200 to 230 VAC, 50/60 Hz Connection terminal: L1, L2, L3
L2		
L3		
N	Do not connect.	
P1	Connect between P1 and P2. (Connected at time of shipping)	
P2		

Control Circuit Power Supply Connector: CNP2 * Accessory

Terminal name	Function	Details
P	Regeneration option	Connect between P and D. (Connected at time of shipping) * If regeneration option is required for "Model Selection," connect to this terminal.
C		
D		
L11	Control circuit power supply	Connect the control circuit power supply. LECSB1/LECS□1/LECS□1: Single phase 100 to 120 VAC, 50/60 Hz Connection terminal: L11, L21 LECSB2/LECS□2/LECS□2: Single phase 200 to 230 VAC, 50/60 Hz Connection terminal: L11, L21
L21		

Motor Connector: CNP3 * Accessory

Terminal name	Function	Details
U	Servo motor power (U)	Connect to motor cable (U, V, W).
V	Servo motor power (V)	
W	Servo motor power (W)	

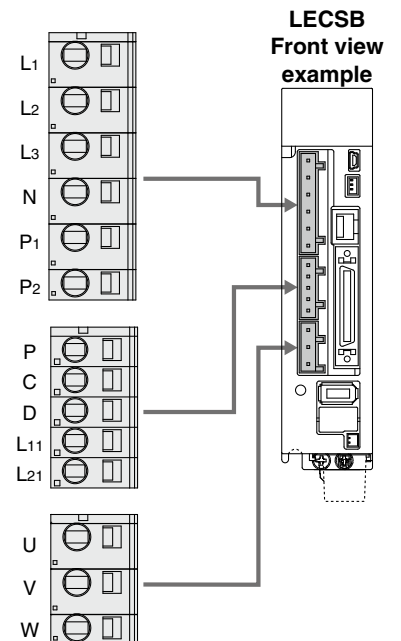

Power Supply Wiring Example: LECSB2-T□, LECSS2-T□

For single phase 200 VAC

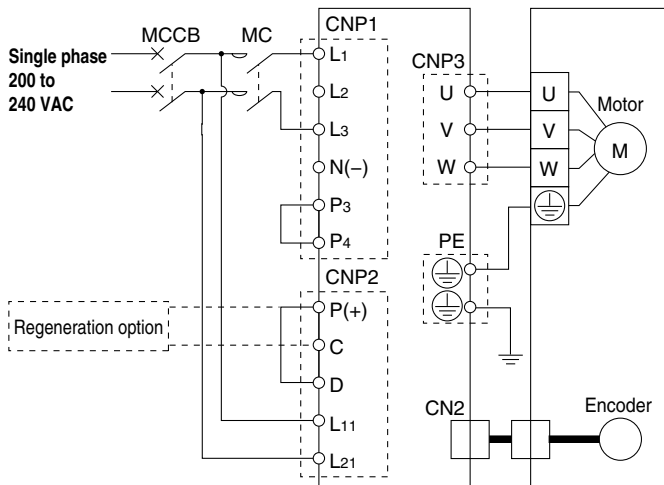

For three phase 200 VAC

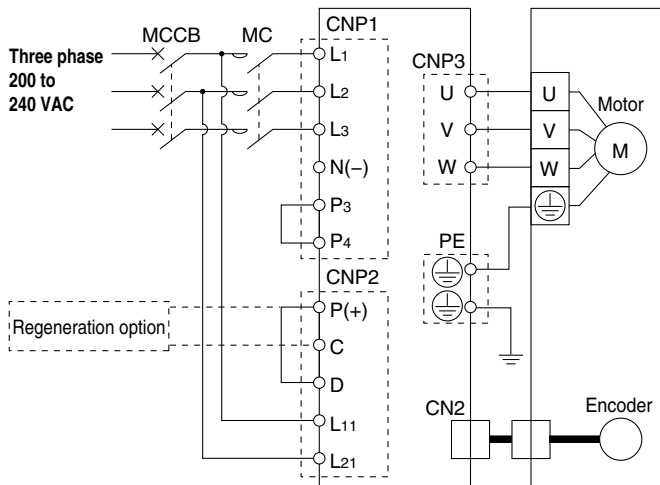

* For single phase 200 to 240 VAC, power supply should be connected to L1 and L3 terminals, with nothing connected to L2. Please note that the wiring locations differ from the LECS□.

Main Circuit Power Supply Connector: CNP1 * Accessory

Terminal name	Function	Details
L1	Main circuit power supply	Connect the main circuit power supply. LECSB2-T/LECSS2-T: Single phase 200 to 240 VAC, 50/60 Hz Connection terminal: L1, L3 Three phase 200 to 240 VAC, 50/60 Hz Connection terminal: L1, L2, L3
L2		
L3		
N(-)		Do not connect.
P3		Connect between P3 and P4. (Connected at time of shipping)
P4		

Control Circuit Power Supply Connector: CNP2 * Accessory

Terminal name	Function	Details
P(+)	Regeneration option	Connect between P(+) and D. (Connected at time of shipping) * If regeneration option is required for "Model Selection," connect to this terminal.
C		
D		
L11	Control circuit power supply	Connect the control circuit power supply. LECSB2-T/LECSS2-T: Single phase 200 to 240 VAC, 50/60 Hz Connection terminal: L11, L21
L21		

Motor Connector: CNP3 * Accessory

Terminal name	Function	Details
U	Servo motor power (U)	Connect to motor cable (U, V, W).
V	Servo motor power (V)	
W	Servo motor power (W)	

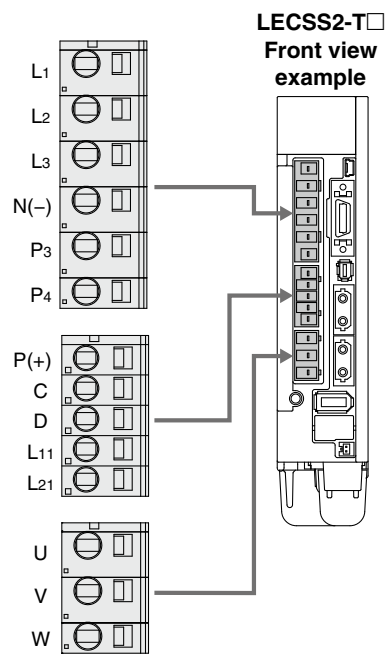

LECS□/LECS□-T Series

Power Supply Wiring Example: LECSC2-□

LECS2-T□

For single phase 200 VAC

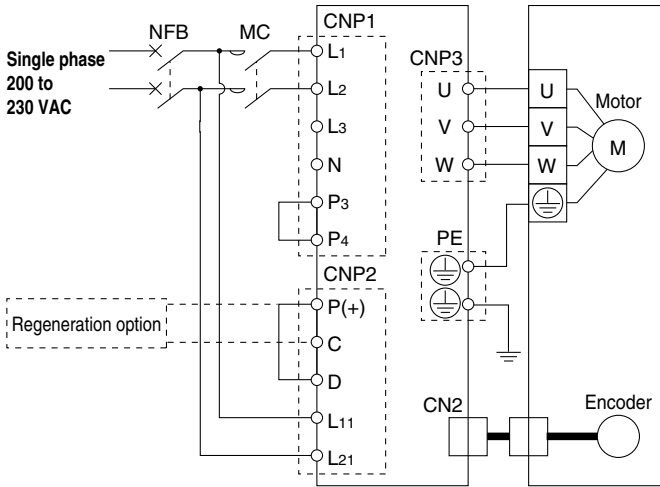

For three phase 200 VAC

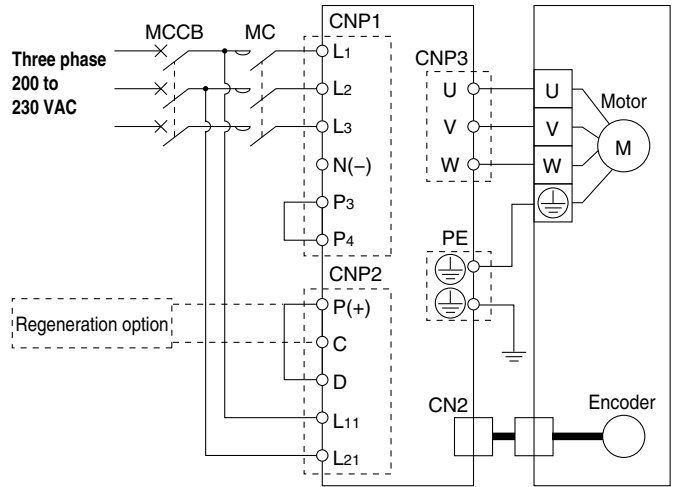

* For single phase 200 to 230 VAC, power supply should be connected to L1 and L2 terminals, with nothing connected to L3.

Main Circuit Power Supply Connector: CNP1 * Accessory

Terminal name	Function	Details
L1	Main circuit power supply	Connect the main circuit power supply. LECS2-T: Single phase 200 to 230 VAC, 50/60 Hz Connection terminal: L1, L2 Three phase 200 to 230 VAC, 50/60 Hz Connection terminal: L1, L2, L3
L2		
L3		
N	Do not connect.	
P3	Connect between P3 and P4. (Connected at time of shipping)	
P4		

Control Circuit Power Supply Connector: CNP2 * Accessory

Terminal name	Function	Details
P(+)	Regeneration option	Connect between P and D. (Connected at time of shipping) * If regeneration option is required for "Model Selection," connect to this terminal.
C		
D		
L11	Control circuit power supply	Connect the control circuit power supply. LECS2-T: Single phase 200 to 230 VAC, 50/60 Hz Connection terminal: L11, L21
L21		

Motor Connector: CNP3 * Accessory

Terminal name	Function	Details
U	Servo motor power (U)	Connect to motor cable (U, V, W).
V	Servo motor power (V)	
W	Servo motor power (W)	

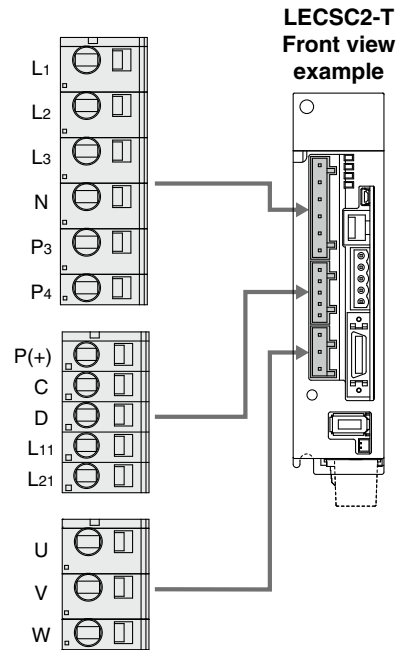

Control Signal Wiring Example: LECSA

LECSA□-□

This wiring example shows connection with a PLC (FX3U-□□MT/ES) manufactured by Mitsubishi Electric Corporation as when used in position control mode. Refer to the LECSA series Operation Manual and any technical literature or operation manuals for your PLC and positioning unit before connecting to another PLC or positioning unit.

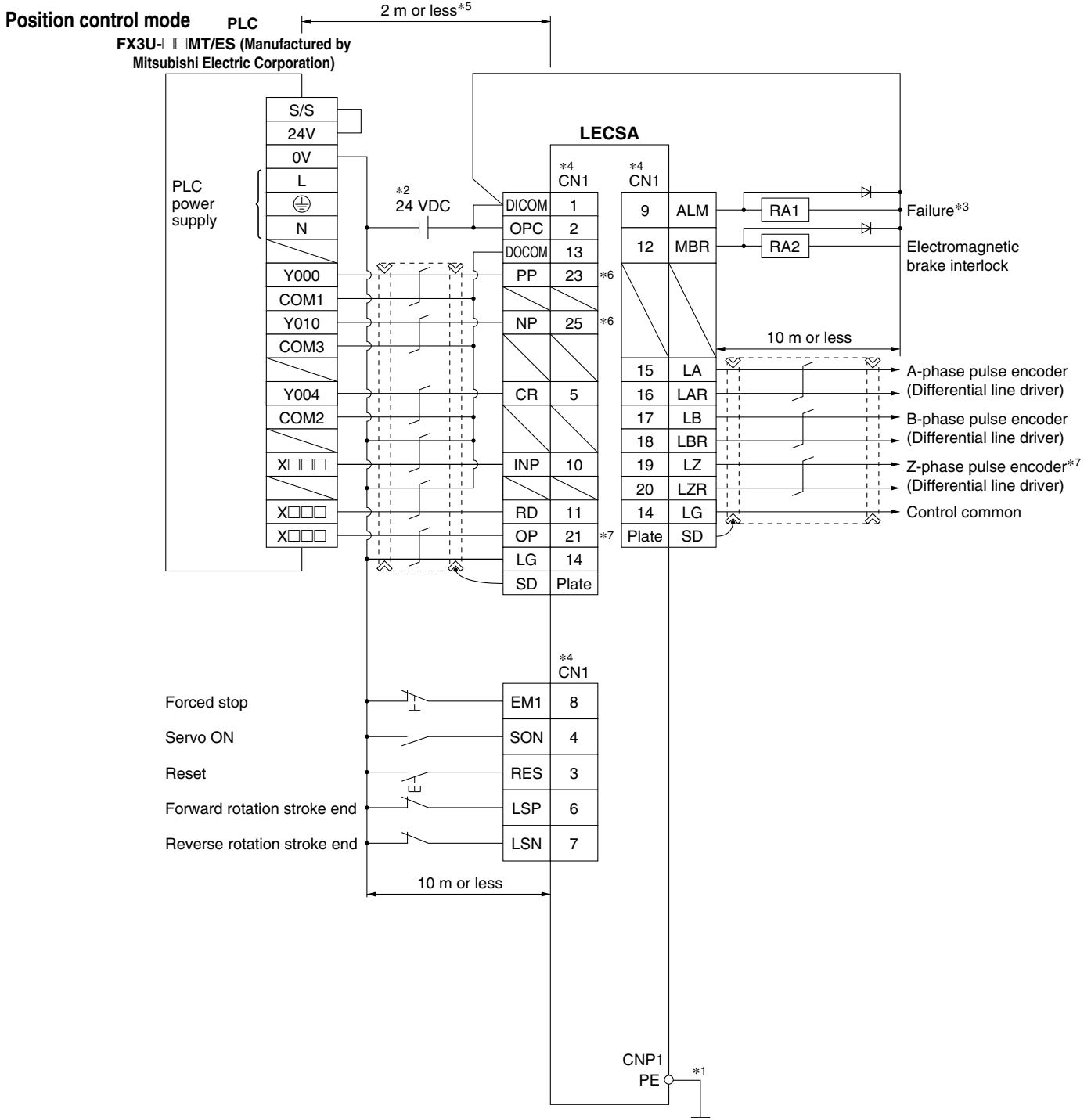

- *1 For preventing electric shock, be sure to connect the driver main circuit power supply connector (CNP1)'s protective earth (PE) terminal (marked ⊕) to the control panel's protective earth (PE).
- *2 For interface use, supply 24 VDC ±10% 200 mA using an external source. 200 mA is the value when all I/O command signals are being used. In addition, reducing the number of inputs/outputs can decrease the current capacity. Refer to the Operation Manual for required current for interface.
- *3 The failure (ALM) is normally ON. When it is OFF (alarm occurs), stop the PLC signal using the sequence program.
- *4 Signals of the same name are connected inside the driver.
- *5 For command pulse input with an open collector method. When a positioning unit loaded with a differential line driver method is used, it is 10 m or less.
- *6 If the command pulse train input is open collector method, it supports only the sink (NPN) type interface. It does not correspond to the source (PNP) type interface.
- *7 The Z-phase pulse encoder corresponds to the differential line driver method and the open collector method. If the Z-phase pulse encoder is using the open collector method, it supports only the sink (NPN) type interface. It does not correspond to the source (PNP) type interface.

LECS□/LECS□-T Series

Control Signal Wiring Example: LECSA

In this wiring example, the device of the CN1-10 pin in the initial status has been changed to the device shown below. For details on the device and changing method, refer to the LECSA series Operation Manual.
CN1-10: MEND (Travel completion)

Positioning mode (Point table method) For sink (NPN) I/O interface

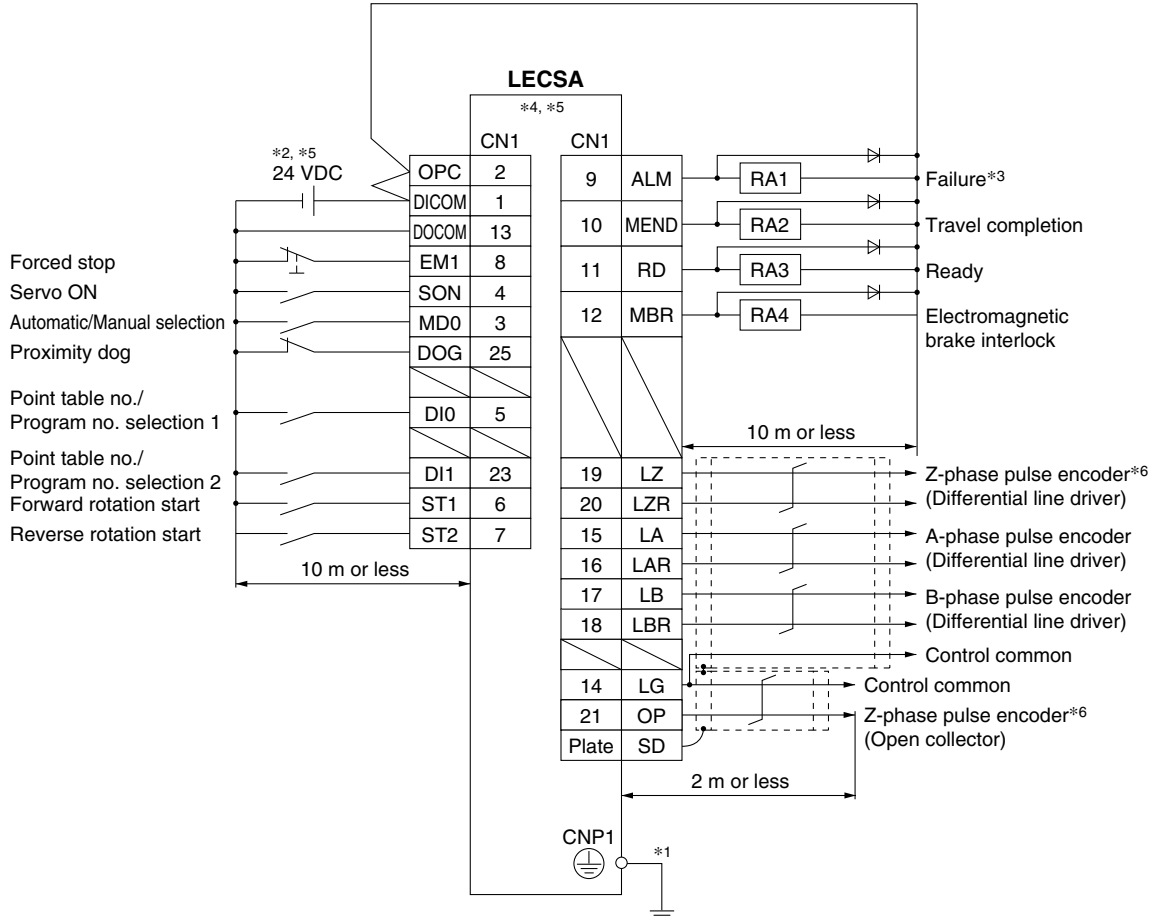

- *1 For preventing electric shock, be sure to connect the driver's protective earth (PE) terminal (marked \oplus) to the control panel's protective earth (PE).
- *2 For interface use, supply 24 VDC $\pm 10\%$ 200 mA using an external source. 200 mA is the value when all I/O command signals are being used. In addition, reducing the number of inputs/outputs can decrease the current capacity.
- *3 The failure (ALM) is normally ON.
- *4 Signals of the same name are connected inside the driver.
- *5 The wiring example is for the sink (NPN) type interface. Refer to the LECSA series Operation Manual for the source (PNP) type interface. Note that the 23 pin and 25 pin cannot be used for the source type interface.
- *6 The Z-phase pulse encoder corresponds to the differential line driver method and the open collector method. If the Z-phase pulse encoder is using the open collector method, it supports only the sink (NPN) type interface. It does not correspond to the source (PNP) type interface.

Control Signal Wiring Example: LECSB

This wiring example shows connection with a positioning unit (QD75D) manufactured by Mitsubishi Electric Corporation as when used in position control mode. Refer to the LECSB series Operation Manual and any technical literature or operation manuals for your PLC and positioning unit before connecting to another PLC or positioning unit.

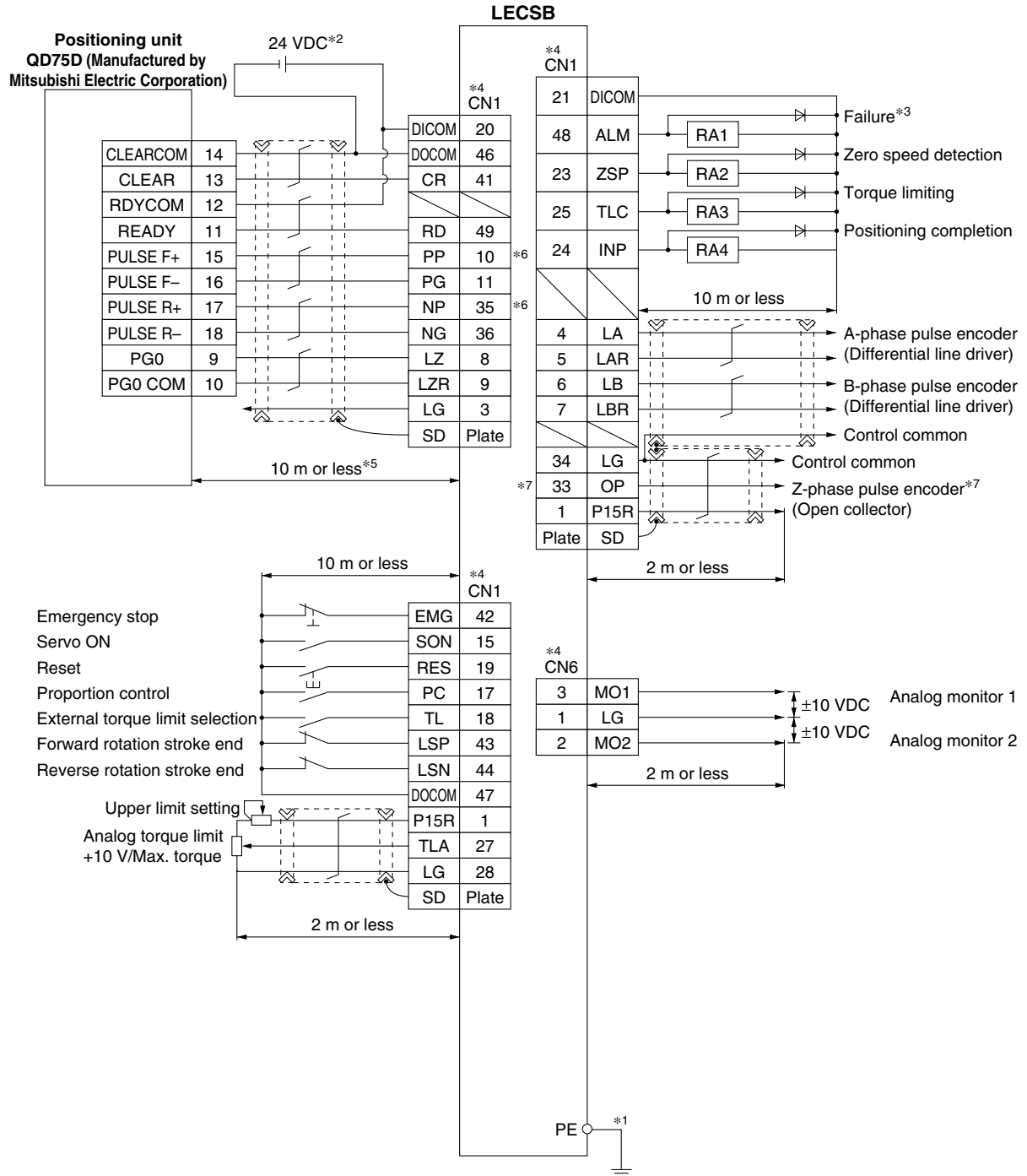

LECS□/LECS□-T Series

Control Signal Wiring Example: LECS□, LECS□-T□

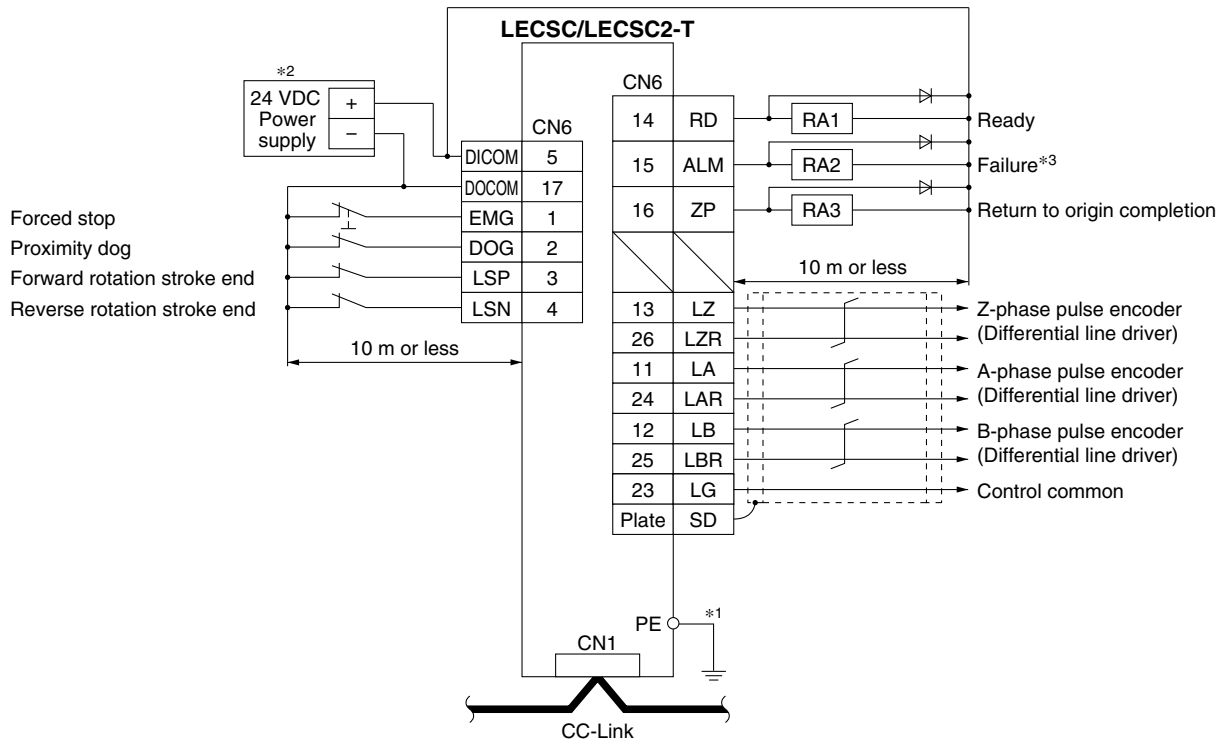

*1 For preventing electric shock, be sure to connect the driver's protective earth (PE) terminal (marked ⊕) to the control panel's protective earth (PE).

*2 For interface use, supply 24 VDC ±10% 150 mA using an external source.

*3 The failure (ALM) is normally ON. When it is OFF (alarm occurs), stop the PLC signal using the sequence program.

Control Signal Wiring Example: LECS□

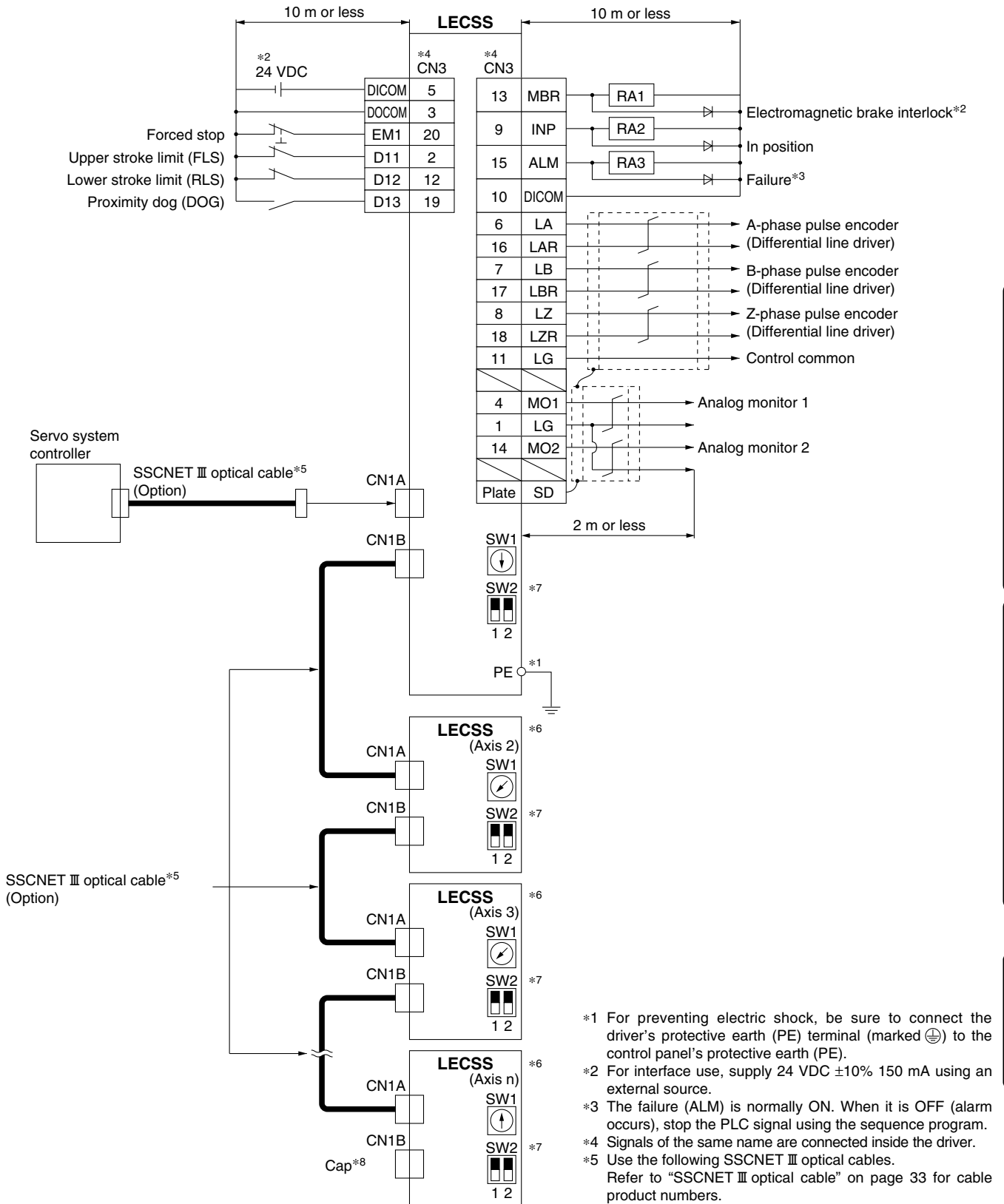

- *1 For preventing electric shock, be sure to connect the driver's protective earth (PE) terminal (marked ⊕) to the control panel's protective earth (PE).
- *2 For interface use, supply 24 VDC ±10% 150 mA using an external source.
- *3 The failure (ALM) is normally ON. When it is OFF (alarm occurs), stop the PLC signal using the sequence program.
- *4 Signals of the same name are connected inside the driver.
- *5 Use the following SSCNET III optical cables. Refer to "SSCNET III optical cable" on page 33 for cable product numbers.

Cable	Product no.	Cable length
SSCNET III optical cable	LE-CSS-□	0.15 m to 3 m

- *6 Connections from Axis 2 onward are omitted.
- *7 Up to 16 axes can be set.
- *8 Be sure to place a cap on unused CN1A/CN1B.

Control Signal Wiring Example: LECSB2-T□

In this wiring example, the devices of the CN1-22 pin, CN1-23 pin, and CN1-25 pin in the initial status have been changed to the devices shown below. For details on the devices and changing method, refer to the LECSB2-T series Operation Manual.
 CN1-22: CPO (Rough match)/CN1-23: ZP (Return to origin completion)/CN1-25: MEND (Travel completion)

Positioning mode (Point table method) For sink (NPN) I/O interface

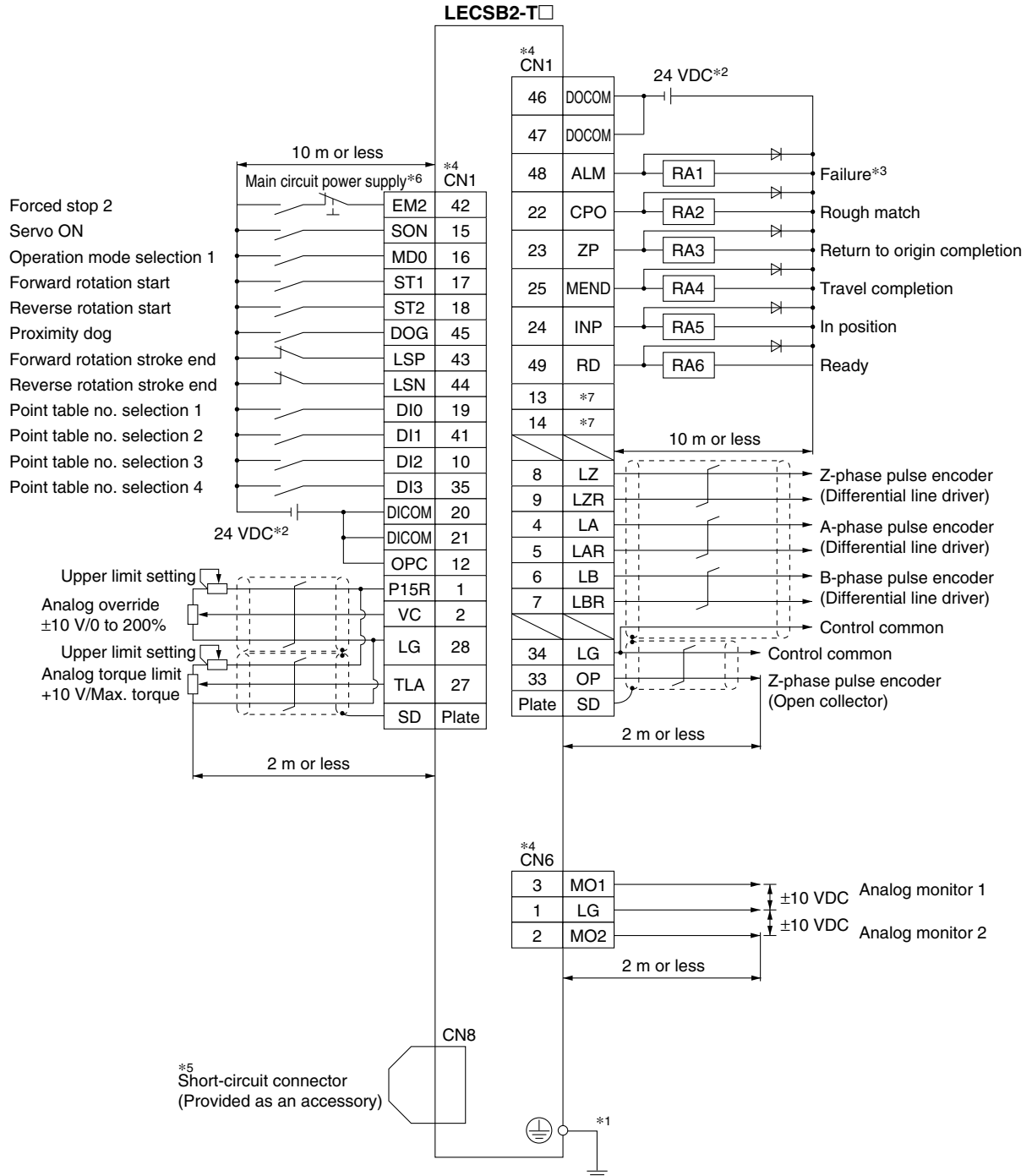

- *1 For preventing electric shock, be sure to connect the servo amplifier's protective earth (PE) terminal (marked ⊕) to the control panel's protective earth (PE).
- *2 For interface use, supply 24 VDC ±10% using an external source. Set the total current capacity to 500 mA. 500 mA is the value when all I/O command signals are being used. In addition, reducing the number of inputs/outputs can decrease the current capacity.
- *3 The ALM (Failure) is normally ON. (Normally closed contact)
- *4 Signals of the same name are connected inside the servo amplifier.
- *5 When not using the STO function, use the servo amplifier with the short-circuit connector (provided as an accessory) inserted.
- *6 Configure a circuit to turn off EM2 when the main circuit power is turned off to prevent any unexpected restarts of the driver.
- *7 Output devices are not assigned in the initial status. Assign the output devices as necessary.

LECS□/LECS□-T Series

Control Signal Wiring Example: LECSS2-T□

For sink (NPN) I/O interface

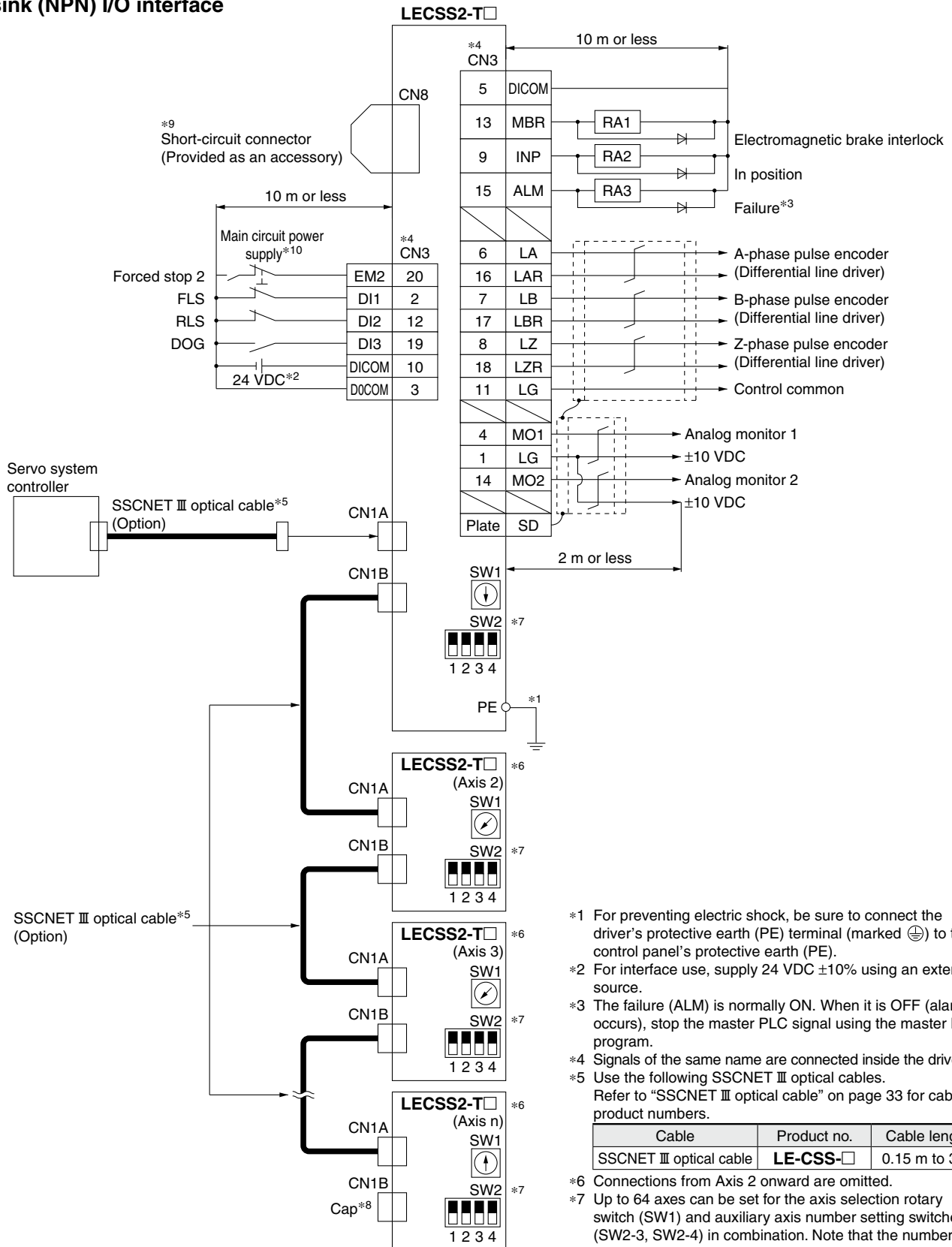

- *1 For preventing electric shock, be sure to connect the driver's protective earth (PE) terminal (marked ⊕) to the control panel's protective earth (PE).
- *2 For interface use, supply 24 VDC ±10% using an external source.
- *3 The failure (ALM) is normally ON. When it is OFF (alarm occurs), stop the master PLC signal using the master PLC program.
- *4 Signals of the same name are connected inside the driver.
- *5 Use the following SSCNET III optical cables. Refer to "SSCNET III optical cable" on page 33 for cable product numbers.

Cable	Product no.	Cable length
SSCNET III optical cable	LE-CSS-□	0.15 m to 3 m

- *6 Connections from Axis 2 onward are omitted.
- *7 Up to 64 axes can be set for the axis selection rotary switch (SW1) and auxiliary axis number setting switches (SW2-3, SW2-4) in combination. Note that the number of connection axes depends on the specifications of the master PLC.
- *8 Be sure to place a cap on unused CN1A/CN1B.
- *9 When not using the STO function, use the driver with the short-circuit connector (provided as an accessory) inserted.
- *10 Configure a circuit to turn off EM2 when the main circuit power is turned off to prevent any unexpected restarts of the driver.

Options

Motor cable, Lock cable, Encoder cable (LECS□, LECS□-T common)

LE - CSM - S 5 A

Motor type
S AC servo motor

Cable description
M Motor cable
B Lock cable
E Encoder cable

Cable type
S Standard cable
R Robotic cable

Cable length (L) [m]

2	2
5	5
A	10

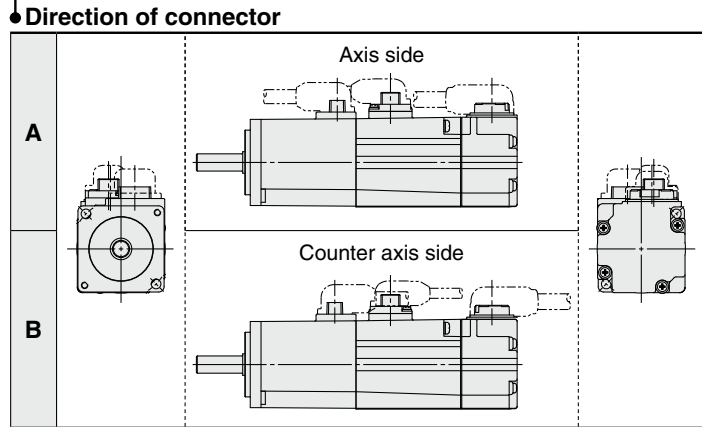

LE-CSM-□□: Motor cable

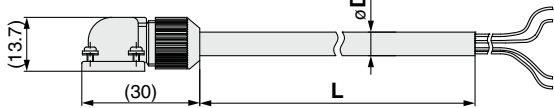

LE-CSB-□□: Lock cable*1

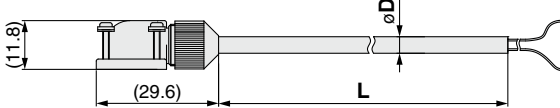

LE-CSE-□□: Encoder cable



*1 If using an actuator with a lock, a lock cable is required.

Product no.	øD
LE-CSM-S□A	6.2
LE-CSM-S□B	6.2
LE-CSM-R□A	5.7
LE-CSM-R□B	5.7

Product no.	øD
LE-CSB-S□A	4.7
LE-CSB-S□B	4.7
LE-CSB-R□A	4.5
LE-CSB-R□B	4.5

Weight

Product no.	Length [m]	Weight [g]
LE-CSM-S2□	2	180
LE-CSM-S5□	5	400
LE-CSM-SA□	10	800
LE-CSM-R2□	2	180
LE-CSM-R5□	5	400
LE-CSM-RA□	10	800

Weight

Product no.	Length [m]	Weight [g]
LE-CSB-S2□	2	80
LE-CSB-S5□	5	200
LE-CSB-SA□	10	400
LE-CSB-R2□	2	80
LE-CSB-R5□	5	200
LE-CSB-RA□	10	400

Weight

Product no.	Length [m]	Weight [g]
LE-CSE-S2□	2	220
LE-CSE-S5□	5	600
LE-CSE-SA□	10	1200
LE-CSE-R2□	2	220
LE-CSE-R5□	5	600
LE-CSE-RA□	10	1200

I/O connector (Without cable, Connector only)

LE - CSN A

Driver type

A	LECSA□, LECS□-S□/LECS□-T□
B	LECSB□-S□/LECSB□-T□
S	LECSS□-S□/LECSS□-T□

LE-CSNA

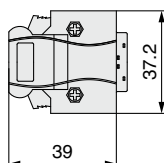

LE-CSNB

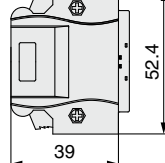

LE-CSNS

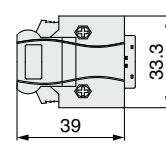

Weight

Product no.	Weight [g]
LE-CSNA	25
LE-CSNB	30
LE-CSNS	16

* LE-CSNA: 10126-3000PE (connector)/10326-52F0-008 (shell kit) manufactured by 3M Japan Limited or equivalent
 LE-CSNB: 10150-3000PE (connector)/10350-52F0-008 (shell kit) manufactured by 3M Japan Limited or equivalent
 LE-CSNS: 10120-3000PE (connector)/10320-52F0-008 (shell kit) manufactured by 3M Japan Limited or equivalent

* Applicable conductor size: AWG24 to 30
 * If using the LECSB, emergency stop (EMG) wiring is required in all cases. If using the LECSB-T in any mode other than positioning mode, forced stop (EM2) wiring is required in all cases. (The electric actuator will not operate without the wiring.)
 Prepare an I/O connector or an I/O cable in advance.

LECS□/LECS□-T Series

LECY□ Series

Specific Product Precautions

LECS□/LECS□-T Series

Options

SSCNET III optical cable (LECSS□-S□, LECS2-T□)

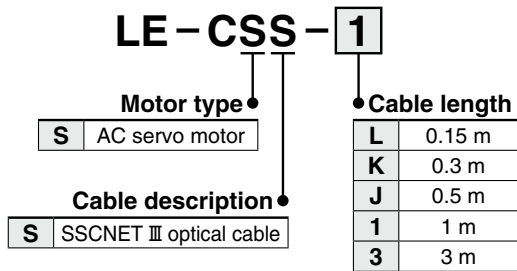

* LE-CSS-□ is MR-J3BUS□M manufactured by Mitsubishi Electric Corporation.

Weight

Product no.	Length [m]	Weight [g]
LE-CSS-L	0.15	100
LE-CSS-K	0.3	100
LE-CSS-J	0.5	200
LE-CSS-1	1	200
LE-CSS-3	3	200

I/O cable

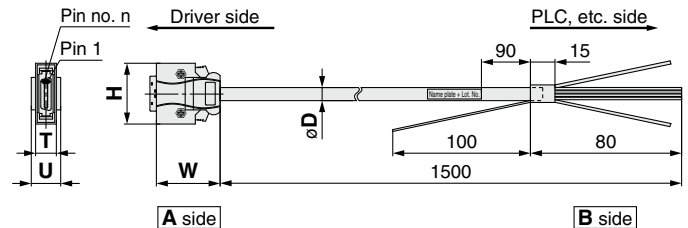
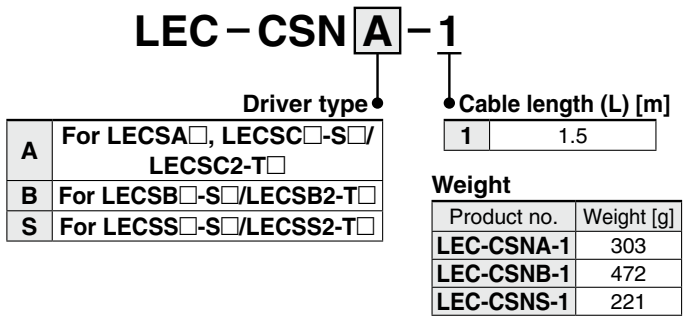

- * LEC-CSNA-1: 10126-3000PE (connector)/10326-52F0-008 (shell kit) manufactured by 3M Japan Limited or equivalent
- * LEC-CSNB-1: 10150-3000PE (connector)/10350-52F0-008 (shell kit) manufactured by 3M Japan Limited or equivalent
- * LEC-CSNS-1: 10120-3000PE (connector)/10320-52F0-008 (shell kit) manufactured by 3M Japan Limited or equivalent
- * Conductor size: AWG24
- * If using the LECSB, emergency stop (EMG) wiring is required in all cases. If using the LECSB-T in any mode other than positioning mode, forced stop (EM2) wiring is required in all cases. (The electric actuator will not operate without the wiring.)
- * Prepare an I/O connector or an I/O cable in advance.

Cable O.D.

Product no.	øD
LEC-CSNA-1	11.1
LEC-CSNB-1	13.8
LEC-CSNS-1	9.1

Dimensions/Pin Nos.

Product no.	W	H	T	U	Pin no. n
LEC-CSNA-1	39	37.2	12.7	14	14
LEC-CSNB-1		52.4		18	26
LEC-CSNS-1		33.3		14	21

Wiring

LEC-CSNA-1: Pin nos. 1 to 26

LEC-CSNB-1: Pin nos. 1 to 50

LEC-CSNS-1: Pin nos. 1 to 20

Connector pin no.	Pair no. of wire	Insulation color	Dot mark	Dot color	
A side	1	1	Orange	■	Red
	2	1	Orange	■	Black
	3	2	Light gray	■	Red
	4	2	Light gray	■	Black
	5	3	White	■	Red
	6	3	White	■	Black
	7	4	Yellow	■	Red
	8	4	Yellow	■	Black
	9	5	Pink	■	Red
	10	5	Pink	■	Black
	11	6	Orange	■ ■	Red
	12	6	Orange	■ ■	Black
	13	7	Light gray	■ ■	Red
	14	7	Light gray	■ ■	Black
	15	8	White	■ ■	Red
	16	8	White	■ ■	Black
	17	9	Yellow	■ ■	Red
	18	9	Yellow	■ ■	Black

Connector pin no.	Pair no. of wire	Insulation color	Dot mark	Dot color	
A side	19	10	Pink	■ ■	Red
	20	10	Pink	■ ■	Black
	21	11	Orange	■ ■ ■	Red
	22	11	Orange	■ ■ ■	Black
	23	12	Light gray	■ ■ ■	Red
	24	12	Light gray	■ ■ ■	Black
	25	13	White	■ ■ ■	Red
	26	13	White	■ ■ ■	Black
	27	14	Yellow	■ ■ ■	Red
	28	14	Yellow	■ ■ ■	Black
	29	15	Pink	■ ■ ■ ■	Red
	30	15	Pink	■ ■ ■ ■	Black
	31	16	Orange	■ ■ ■ ■	Red
	32	16	Orange	■ ■ ■ ■	Black
	33	17	Light gray	■ ■ ■ ■	Red
	34	17	Light gray	■ ■ ■ ■	Black

Connector pin no.	Pair no. of wire	Insulation color	Dot mark	Dot color	
A side	35	18	White	■ ■ ■ ■ ■	Red
	36	18	White	■ ■ ■ ■ ■	Black
	37	19	Yellow	■ ■ ■ ■ ■	Red
	38	19	Yellow	■ ■ ■ ■ ■	Black
	39	20	Pink	■ ■ ■ ■ ■	Red
	40	20	Pink	■ ■ ■ ■ ■	Black
	41	21	Orange	■ ■ ■ ■ ■	Red
	42	21	Orange	■ ■ ■ ■ ■	Black
	43	22	Light gray	■ ■ ■ ■ ■	Red
	44	22	Light gray	■ ■ ■ ■ ■	Black
	45	23	White	■ ■ ■ ■ ■	Red
	46	23	White	■ ■ ■ ■ ■	Black
	47	24	Yellow	■ ■ ■ ■ ■	Red
	48	24	Yellow	■ ■ ■ ■ ■	Black
	49	25	Pink	■ ■ ■ ■ ■	Red
	50	25	Pink	■ ■ ■ ■ ■	Black

Options

Regeneration option (LECS□ common)

LEC-MR-RB-12

Regeneration option type

032	Allowable regenerative power 30 W
12	Allowable regenerative power 100 W

* Confirm regeneration option to be used in "Model Selection."

LEC-MR-RB-032

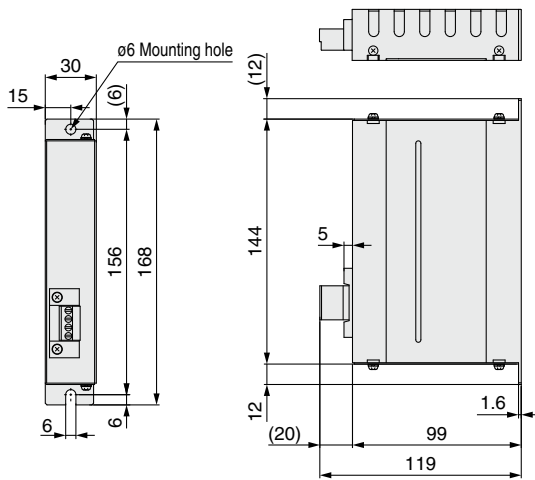

LEC-MR-RB-12

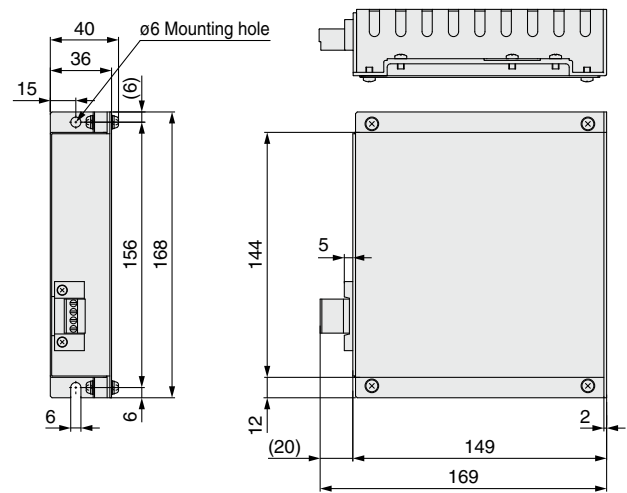

Weight

Product no.	Weight [kg]
LEC-MR-RB-032	0.5

* MR-RB032 manufactured by Mitsubishi Electric Corporation

Weight

Product no.	Weight [kg]
LEC-MR-RB-12	1.1

* MR-RB12 manufactured by Mitsubishi Electric Corporation

LECS□/LECS□-T Series

LECY□ Series

Specific Product Precautions

LECS□/LECS□-T Series

Options

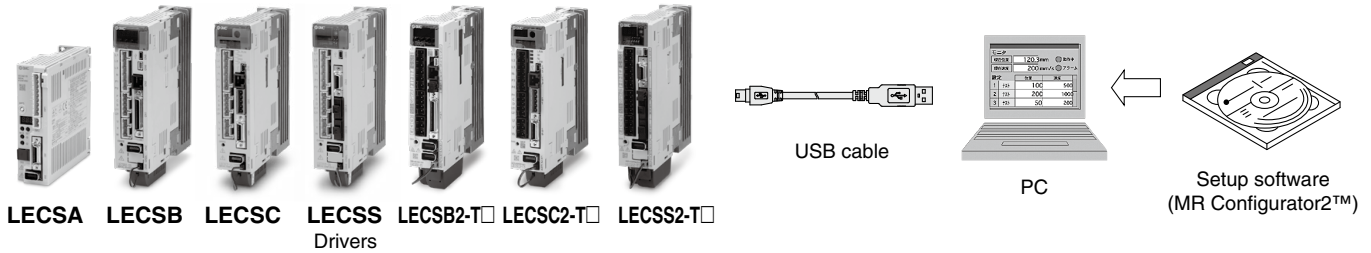

Setup software (MR Configurator2™) (LECSA, LECSB, LECS□, LECS□, LECSB2-T□, LECS□2-T□, LECS□2-T□ common)

LEC-MRC2□

Display language

N il	Japanese version
E	English version
C	Chinese version

* SW1DNC-MRC2□ manufactured by Mitsubishi Electric Corporation. Refer to Mitsubishi Electric Corporation's website for operating environment and version upgrade information. MR Configurator2™ is a registered trademark or trademark of Mitsubishi Electric Corporation.

Adjustment, waveform display, diagnostics, parameter read/write, and test operation can be performed upon a PC.

Compatible PC

When using setup software (MR Configurator2™), use an IBM PC/AT compatible PC that meets the following operating conditions.

Hardware Requirements

Equipment	Setup software (MR Configurator2™) LEC-MRC2□	
*1, 2, 3, 4, 5, 6, 7, 8, 9, 10 PC	OS	<p>Microsoft® Windows® 10 Edition Operating System</p> <p>Microsoft® Windows® 10 Enterprise Operating System</p> <p>Microsoft® Windows® 10 Pro Operating System</p> <p>Microsoft® Windows® 10 Home Operating System</p> <p>Microsoft® Windows® 8.1 Enterprise Operating System</p> <p>Microsoft® Windows® 8.1 Pro Operating System</p> <p>Microsoft® Windows® 8.1 Operating System</p> <p>Microsoft® Windows® 8 Enterprise Operating System</p> <p>Microsoft® Windows® 8 Pro Operating System</p> <p>Microsoft® Windows® 8 Operating System</p> <p>Microsoft® Windows® 7 Ultimate Operating System</p> <p>Microsoft® Windows® 7 Enterprise Operating System</p> <p>Microsoft® Windows® 7 Professional Operating System</p> <p>Microsoft® Windows® 7 Home Premium Operating System</p> <p>Microsoft® Windows® 7 Starter Operating System</p> <p>Microsoft® Windows Vista® Ultimate Operating System</p> <p>Microsoft® Windows Vista® Enterprise Operating System</p> <p>Microsoft® Windows Vista® Business Operating System</p> <p>Microsoft® Windows Vista® Home Premium Operating System</p> <p>Microsoft® Windows Vista® Home Basic Operating System</p> <p>Microsoft® Windows® XP Professional Operating System, Service Pack 3 or later</p> <p>Microsoft® Windows® XP Home Edition Operating System, Service Pack 3 or later</p>
	Hard disk	1 GB or more of free space
	Communication interface	Use USB port.
	Display	Resolution 1024 x 768 or more Must be capable of high color (16-bit) display. Connectable with the PC above
	Keyboard	Connectable with the PC above
	Mouse	Connectable with the PC above
	Printer	Connectable with the PC above
	USB cable*11	LEC-MR-J3USB

Setup Software Compatible Drivers

Compatible driver	Setup software	
	MR Configurator™ LEC-MR-SETUP221□	MR Configurator2™ LEC-MRC2□
LECSA	○	○
LECSB□-S□	○	○
LECS□-S□	○	○
LECS□-S□	○	○
LECSB2-T□	—	○
LECS□2-T□	—	○
LECS□2-T□	—	○

- *1 Before using a PC for setting LECSA point table method/program operation method, upgrade to version 1.18U (Japanese version)/ version 1.19V (English version) or later. Refer to Mitsubishi Electric Corporation's website for version upgrade information.
- *2 Windows® and Windows Vista® are registered trademarks of Microsoft Corporation in the United States and other countries.
- *3 On some PCs, setup software (MR Configurator2™) may not run properly.
- *4 The following functions cannot be used. If any of the following functions is used, this product may not operate normally.
 - Start of application in Windows® compatible mode
 - Fast User Switching
 - Remote Desktop
 - Windows XP Mode
 - Windows Touch or Touch
 - Modern UI
 - Client Hyper-V
 - Tablet Mode
 - Virtual desktop
 - 64-bit OSs are not supported, except for Microsoft® Windows®7 or later.
- *5 Multi-display is set, the screen of this product may not operate normally.
- *6 The size of the text or other items on the screen is not changed to the specified value (96 DPI, 100%, 9 pt, etc.), the screen of this product may not operate normally.
- *7 Changed the resolution of the screen during operating, the screen of this product may not operate normally.
- *8 Please use "Standard User," "Administrator" in Windows Vista® or later.
- *9 Using a PC for setting Windows®10, upgrade to version 1.52E or later.
Using a PC for setting Windows®8.1, upgrade to version 1.25B or later.
Using a PC for setting Windows®8, upgrade to version 1.20W or later.
Refer to Mitsubishi Electric Corporation's website for version upgrade information.
- *10 If .NET Framework 3.5 (including .NET 2.0 and 3.0) have been disabled in Windows®7 or later, it is necessary to enable it.
- *11 Order USB cable separately.
 - This cable is compatible with the setup software (MR Configurator™: LEC-MR-SETUP221□).

Options

USB cable (3 m)
 (LECSA, LECSB, LECSA, LECSB, LECSB-T,
 LECSA-T, LECSB-T common)

LEC – MR – J3USB

* MR-J3USBCBL3M manufactured by Mitsubishi Electric Corporation
 Weight: 140 g

Cable for connecting PC and driver when using the setup software (MR Configurator2™)
 Do not use any cable other than this cable.

STO cable (3 m)
 (Only for LECSB2-T□ and LECSA2-T□)

LEC – MR – D05UDL3M

* MR-D05UDL3M manufactured by Mitsubishi Electric Corporation

Cable for connecting the driver and device, when using the safety function
 Do not use any cable other than this cable.

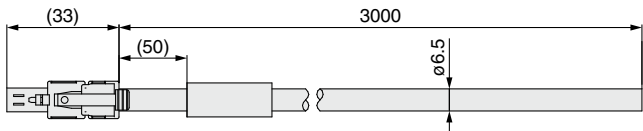

Weight: 500 g

Battery

LEC – MR – J3BAT

* MR-J3BAT manufactured by Mitsubishi Electric Corporation

Battery for replacement

Absolute position data is maintained by installing the battery to the driver.

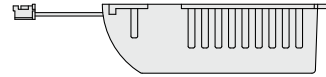

Weight: 30 g

* The LEC-MR-J3BAT is a single battery that uses lithium metal battery ER6V.

When transporting lithium metal batteries and devices with built-in lithium metal batteries by a method subject to UN regulations, it is necessary to apply measures according to the regulations stipulated in the United Nations Recommendations on the Transport of Dangerous Goods, the Technical Instructions (ICAO-TI) of the International Civil Aviation Organization (ICAO), and the International Maritime Dangerous Goods Code (IMDG CODE) of the International Maritime Organization (IMO). If a customer is transporting products such as shown above, it is necessary to confirm the latest regulations, or the laws and regulations of the country of transport on your own, in order to apply the proper measures. Please contact SMC sales representative for details.

LEC – MR – BAT6V1SET

* MR-BAT6V1SET manufactured by Mitsubishi Electric Corporation

Battery for replacement

Absolute position data is maintained by installing the battery to the driver.

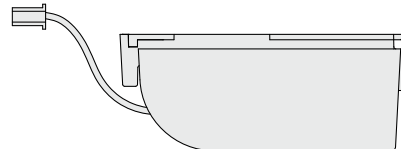

Weight: 60 g

* The LEC-MR-BAT6V1SET is an assembled battery that uses lithium metal battery 2CR17335A.

When transporting lithium metal batteries and devices with built-in lithium metal batteries by a method subject to UN regulations, it is necessary to apply measures according to the regulations stipulated in the United Nations Recommendations on the Transport of Dangerous Goods, the Technical Instructions (ICAO-TI) of the International Civil Aviation Organization (ICAO), and the International Maritime Dangerous Goods Code (IMDG CODE) of the International Maritime Organization (IMO). If a customer is transporting products such as shown above, it is necessary to confirm the latest regulations, or the laws and regulations of the country of transport on your own, in order to apply the proper measures. Please contact SMC sales representative for details.

Battery Types and Compatible Drivers

Compatible driver	Battery type	
	LEC-MR-J3BAT	LEC-MR-BAT6V1SET
LECSB□-S□	○	—
LECSA□-S□	○	—
LECSB□-T□	—	○
LECSA□-T□	○	—
LECSB□-T□	—	○

LECS□/LECS□-T Series

LECY□ Series

Specific Product Precautions

AC Servo Motor Driver Absolute Type

LECYM/LECYU Series

(MECHATROLINK-II Type) (MECHATROLINK-III Type)

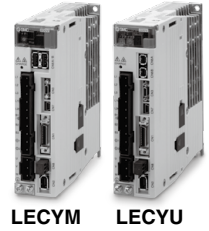

How to Order

Driver

LECY M 2 -

Driver type

M	MECHATROLINK-II type (For absolute encoder)
U	MECHATROLINK-III type (For absolute encoder)

Power supply voltage

2	200 to 230 VAC, 50/60 Hz
---	--------------------------

- * If an I/O connector (CN1) is required, order the part number "LE-CYNA" separately.
- * If an I/O cable (CN1) is required, order the part number "LEC-CSNA-1" separately.

Compatible motor type

Symbol	Type	Capacity	Encoder
V5	AC servo motor (V6 *1)	100 W	Absolute
V7	AC servo motor (V7 *1)	200 W	
V8	AC servo motor (V8 *1)	400 W	

*1 The symbol shows the motor type (actuator).

Dimensions

MECHATROLINK-II type

LECYM2-V□

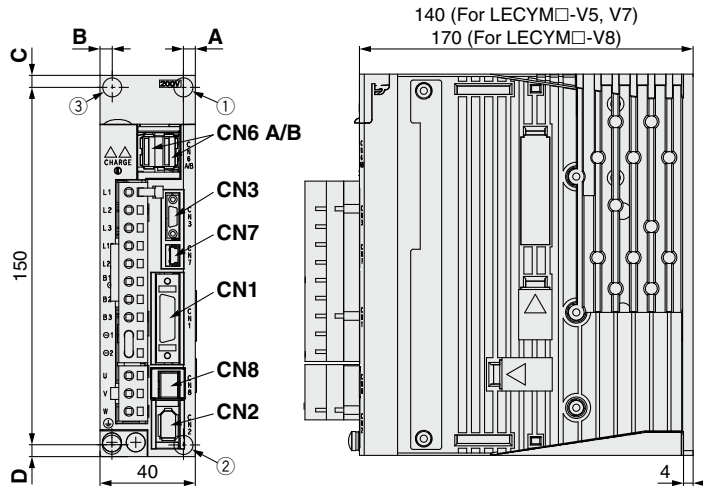

Connector name	Description
CN1	I/O signal connector
CN2	Encoder connector
CN3*1	Digital operator connector
CN6A	MECHATROLINK-II communication connector
CN6B	MECHATROLINK-II communication connector
CN7	PC connector
CN8	Safety connector

*1 Digital operator is JUSP-OP05A-1-E manufactured by YASKAWA Electric Corporation. When using the digital operator, it should be provided by the customer.

Motor capacity	Hole position	Mounting dimensions	Mounting hole
		A B C D	
V5 (100 W)	①②	5 — 5 5	ø5
V7 (200 W)	①②	5 — 5 5	
V8 (400 W)	②③	5 5 5 5	

* The mounting hole position varies depending on the motor capacity.

MECHATROLINK-III type

LECYU2-V□

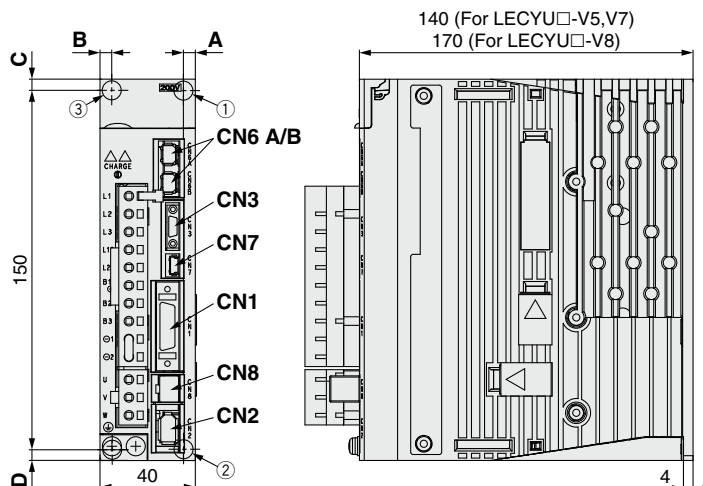

Connector name	Description
CN1	I/O signal connector
CN2	Encoder connector
CN3*1	Digital operator connector
CN6A	MECHATROLINK-III communication connector
CN6B	MECHATROLINK-III communication connector
CN7	PC connector
CN8	Safety connector

*1 Digital operator is JUSP-OP05A-1-E manufactured by YASKAWA Electric Corporation. When using the digital operator, it should be provided by the customer.

Motor capacity	Hole position	Mounting dimensions	Mounting hole
		A B C D	
V5 (100 W)	①②	5 — 5 5	ø5
V7 (200 W)	①②	5 — 5 5	
V8 (400 W)	②③	5 5 5 5	

* The mounting hole position varies depending on the motor capacity.

Specifications

MECHATROLINK-II Type

Model		LECYM2-V5	LECYM2-V7	LECYM2-V8
Compatible motor capacity [W]		100	200	400
Compatible encoder		Absolute 20-bit encoder (Resolution: 1,048,576 p/rev)		
Main circuit power supply	Power voltage [V]	Three phase 200 to 230 VAC (50/60 Hz)		
	Allowable voltage fluctuation [V]	Three phase 170 to 253 VAC		
Control power supply	Power voltage [V]	Single phase 200 to 230 VAC (50/60 Hz)		
	Allowable voltage fluctuation [V]	Single phase 170 to 253 VAC		
Power supply capacity (at rated output) [A]		0.91	1.6	2.8
Input circuit		NPN (Sink circuit)/PNP (Source circuit)		
Parallel input (7 inputs)	Number of optional allocations	7 inputs	[Initial allocation] · Homing deceleration switch (/DEC) · External latch (/EXT 1 to 3) · Forward run prohibited (P-OT), reverse run prohibited (N-OT) [Can be allocated by setting the parameters] · Forward external torque limit (/P-CL), reverse external torque limit (/N-CL) Signal allocations can be performed, and positive and negative logic can be changed.	
			Number of fixed allocations	1 output
Parallel output (4 outputs)	Number of optional allocations	3 outputs	[Initial allocation] · Lock (/BK) [Can be allocated by setting the parameters] · Positioning completion (/COIN) · Speed limit detection (/VLT) · Speed coincidence detection (/V-CMP) · Rotation detection (/TGON) · Warning (/WARN) · Servo ready (/S-RDY) · Near (/NEAR) · Torque limit detection (/CLT) Signal allocations can be performed, and positive and negative logic can be changed.	
MECHATROLINK communication	Communication protocol	MECHATROLINK-II		
	Station address	41H to 5FH		
	Transmission speed	10 Mbps		
	Transmission cycle	250 μs, 0.5 ms to 4 ms (Multiples of 0.5 ms)		
	Number of transmission bytes	17 bytes, 32 bytes		
	Max. number of stations	30		
	Cable length	Overall cable length: 50 m or less, Cable length between the stations: 0.5 m or more		
Command method	Control method	Position, speed, or torque control with MECHATROLINK-II communication		
	Command input	MECHATROLINK-II command (Motion, data setting, monitoring or adjustment)		
Function	Gain adjustment	Tuning-less/Advanced auto tuning/One-parameter tuning		
	Communication setting	USB communication, RS-422 communication		
	Torque limit	Internal torque limit, external torque limit, and torque limit by analog command		
	Encoder output	Phase A, B, Z: Line driver output		
	Emergency stop	CN8 Safety function		
	Overtravel	Dynamic brake stop, deceleration to a stop, or free run to a stop at P-OT or N-OT		
Alarm	Alarm signal, MECHATROLINK-II command			
Operating temperature range [°C]		0 to 55 (No freezing)		
Operating humidity range [%RH]		90 or less (No condensation)		
Storage temperature range [°C]		-20 to 85 (No freezing)		
Storage humidity range [%RH]		90 or less (No condensation)		
Insulation resistance [MΩ]		10 MΩ (500 VDC)		
Weight [g]		900		1000

LECS□/LECS□-T Series

LECY□ Series

Specific Product Precautions

Specifications

MECHATROLINK-III Type

Model			LECYU2-V5	LECYU2-V7	LECYU2-V8
Compatible motor capacity [W]			100	200	400
Compatible encoder			Absolute 20-bit encoder (Resolution: 1,048,576 p/rev)		
Main circuit power supply	Power voltage [V]		Three phase 200 to 230 VAC (50/60 Hz)		
	Allowable voltage fluctuation [V]		Three phase 170 to 253 VAC		
Control power supply	Power voltage [V]		Single phase 200 to 230 VAC (50/60 Hz)		
	Allowable voltage fluctuation [V]		Single phase 170 to 253 VAC		
Power supply capacity (at rated output) [A]			0.91	1.6	2.8
Input circuit			NPN (Sink circuit)/PNP (Source circuit)		
Parallel input (7 inputs)	Number of optional allocations	7 inputs	[Initial allocation] · Homing deceleration switch (/DEC) · External latch (/EXT 1 to 3) · Forward run prohibited (P-OT), reverse run prohibited (N-OT) [Can be allocated by setting the parameters] · Forward external torque limit (/P-CL), reverse external torque limit (/N-CL) Signal allocations can be performed, and positive and negative logic can be changed.		
			Number of fixed allocations	1 output	· Servo alarm (ALM)
Parallel output (4 outputs)	Number of optional allocations	3 outputs	[Initial allocation] · Lock (/BK) [Can be allocated by setting the parameters] · Positioning completion (/COIN) · Speed limit detection (/VLT) · Speed coincidence detection (/V-CMP) · Rotation detection (/TGON) · Warning (/WARN) · Servo ready (/S-RDY) · Near (/NEAR) · Torque limit detection (/CLT) Signal allocations can be performed, and positive and negative logic can be changed.		
MECHATROLINK communication	Communication protocol		MECHATROLINK-III		
	Station address		03H to EFH		
	Transmission speed		100 Mbps		
	Transmission cycle		125 μs, 250 μs, 500 μs, 750 μs, 1 ms to 4 ms (Multiples of 0.5 ms)		
	Number of transmission bytes		16 bytes, 32 bytes, 48 bytes,		
	Max. number of stations		62		
	Cable length		Cable length between the stations: 0.5 m or more, 75 m or less		
Command method	Control method		Position, speed, or torque control with MECHATROLINK-III communication		
	Command input		MECHATROLINK-III command (Motion, data setting, monitoring or adjustment)		
Function	Gain adjustment		Tuning-less/Advanced auto tuning/One-parameter tuning		
	Communication setting		USB communication, RS-422 communication		
	Torque limit		Internal torque limit, external torque limit, and torque limit by analog command		
	Encoder output		Phase A, B, Z: Line driver output		
	Emergency stop		CN8 Safety function		
	Overtravel		Dynamic brake stop, deceleration to a stop, or free run to a stop at P-OT or N-OT		
Alarm		Alarm signal, MECHATROLINK-III command			
Operating temperature range [°C]			0 to 55 (No freezing)		
Operating humidity range [%RH]			90 or less (No condensation)		
Storage temperature range [°C]			-20 to 85 (No freezing)		
Storage humidity range [%RH]			90 or less (No condensation)		
Insulation resistance [MΩ]			10 MΩ (500 VDC)		
Weight [g]			900		1000

Power Supply Wiring Example: LECY□

■ Three phase 200 V **LECYM2-□**
 LECYU2-□

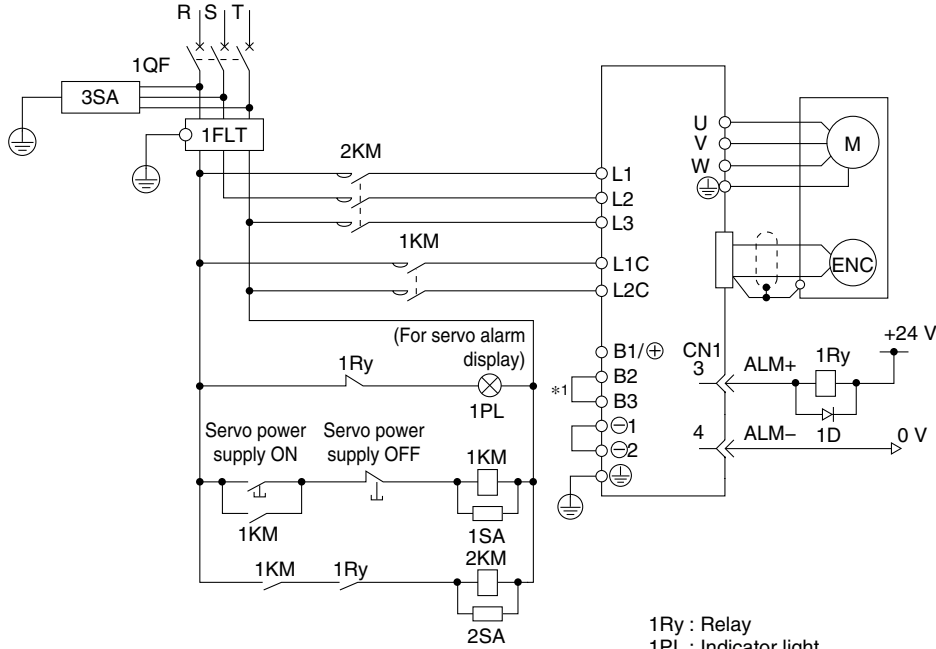

1QF : Molded-case circuit breaker
 1FLT: Noise filter
 1KM : Magnetic contactor (for control power supply)
 2KM : Magnetic contactor (for main circuit power supply)

1Ry : Relay
 1PL : Indicator light
 1SA : Surge absorber
 2SA : Surge absorber
 3SA : Surge absorber
 1D : Flywheel diode

*1 For the LECY□2-V5, LECY□2-V7 and LECY□2-V8, terminals B2 and B3 are not short-circuited. Do not short-circuit these terminals.

Main Circuit Power Supply Connector * Accessory

Terminal name	Function	Details
L1	Main circuit power supply	Connect the main circuit power supply. Single phase 200 to 230 VAC, 50/60 Hz Connection terminal: L1, L2 Three phase 200 to 230 VAC, 50/60 Hz Connection terminal: L1, L2, L3
L2		
L3		
L1C	Control power supply	Connect the control power supply. Single phase 200 to 230 VAC, 50/60 Hz Connection terminal: L1C, L2C
L2C		
B1(+)	External regenerative resistor connection terminal	When the regenerative resistor is required, connect it between terminals B1(+) and B2.
B2		
B3		
⊖1	Main circuit negative terminal	⊖1 and ⊖2 are connected at shipment.
⊖2		

Motor Connector * Accessory

Terminal name	Function	Details
U	Servo motor power (U)	Connect to motor cable (U, V, W).
V	Servo motor power (V)	
W	Servo motor power (W)	

Power Supply Wire Specifications

Item	Specifications
Applicable wire size	L1, L2, L3, L1C, L2C Single wire, Twisted wire, AWG14 (2.0 mm ²)
Stripped wire length	8 to 9 mm

Main circuit power supply connector

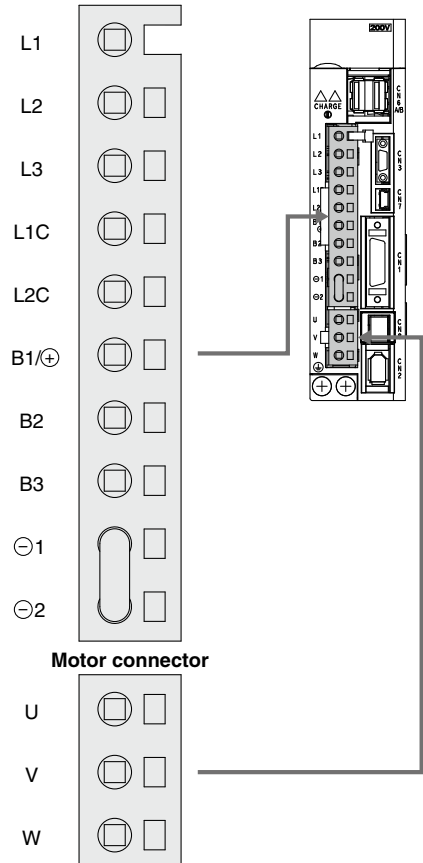

LECS□/LECS□-T Series

LECY□ Series

Specific Product Precautions

Control Signal Wiring Example: LECYM

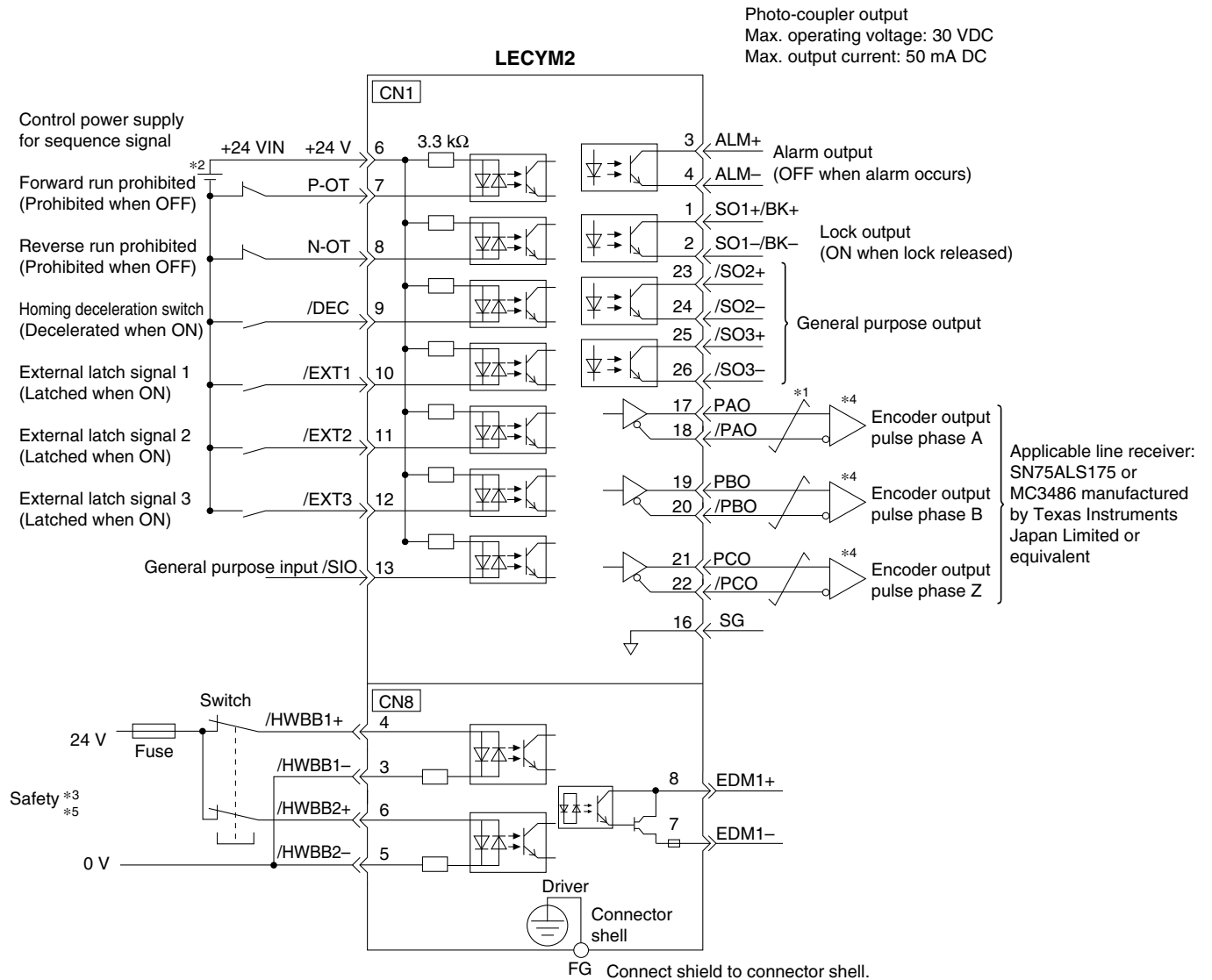

*1 $\overline{\text{---}}$ shows twisted-pair wires.

*2 The 24 VDC power supply is not included. Use a 24 VDC power supply with double insulation or reinforced insulation.

*3 When using the safety function, a safety function device must be connected to the wiring that is necessary to activate the safety function. Otherwise, the servo motor is not turned ON. When not using the safety function, use the driver with the Safety Jumper Connector (provided as an accessory) inserted into the CN8.

*4 Always use line receivers to receive the output signals.

** The functions allocated to the input signals /DEC, P-OT, N-OT, /EXT1, /EXT2 and /EXT3, and the output signals /SO1, /SO2 and /SO3 can be changed by setting the parameters.

*5 It is a safety function equivalent to the STO function (IEC 61800-5-2) using the hard wire base block function (HWBB).

Control Signal Wiring Example: LECYU

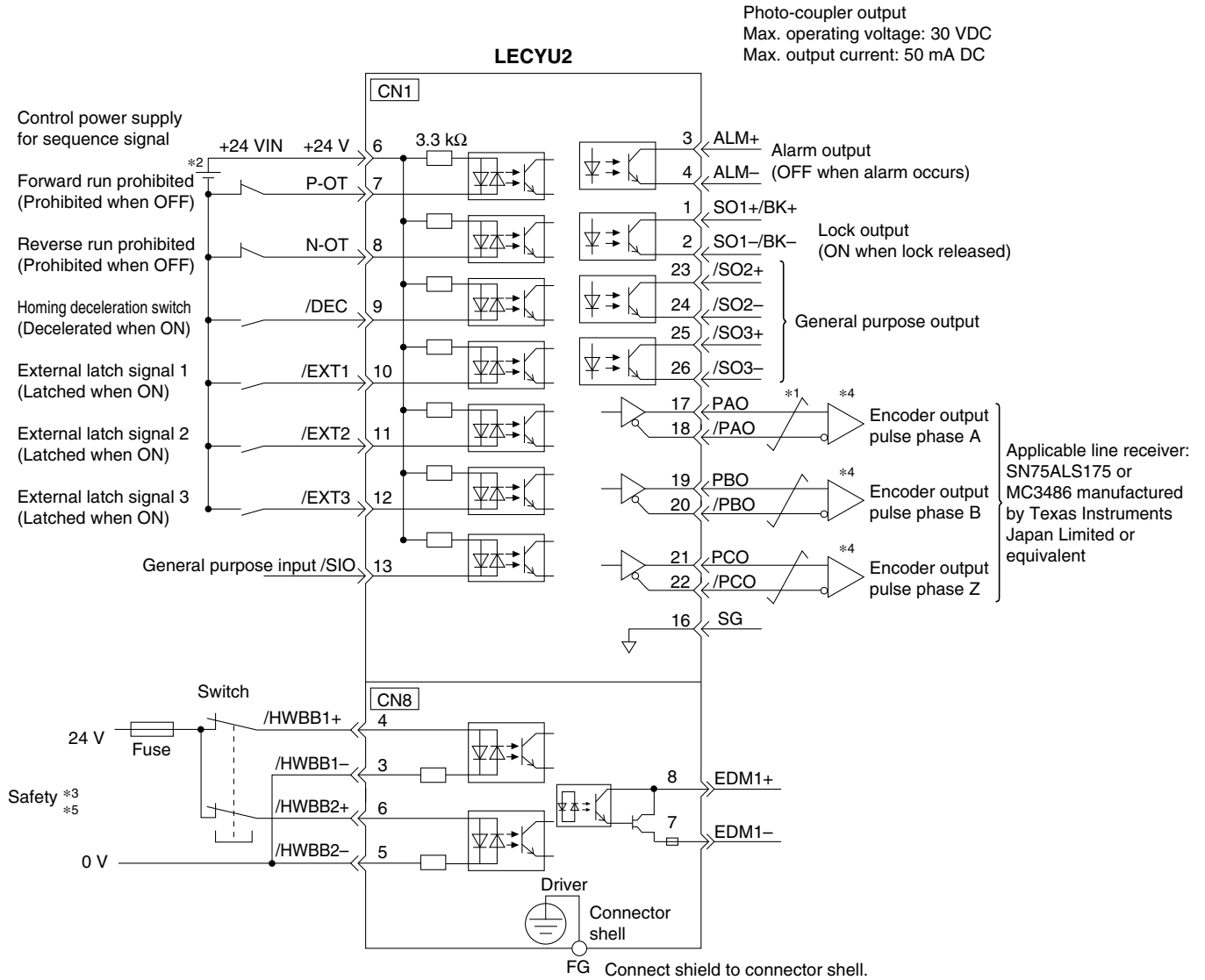

- *1 $\overline{\text{---}}$ shows twisted-pair wires.
- *2 The 24 VDC power supply is not included. Use a 24 VDC power supply with double insulation or reinforced insulation.
- *3 When using the safety function, a safety function device must be connected to the wiring that is necessary to activate the safety function. Otherwise, the servo motor is not turned ON. When not using the safety function, use the driver with the Safety Jumper Connector (provided as an accessory) inserted into the CN8.
- *4 Always use line receivers to receive the output signals.
** The functions allocated to the input signals /DEC, P-OT, N-OT, /EXT1, /EXT2 and /EXT3, and the output signals /SO1, /SO2 and /SO3 can be changed by setting the parameters.
- *5 It is a safety function equivalent to the STO function (IEC 61800-5-2) using the hard wire base block function (HWBB).

LECS□/LECS□-T Series

LECY□ Series

Specific Product Precautions

Options

Motor cable, Motor cable for lock option, Encoder cable (LECYM/LECYU common)

LE-CYM-□□A-□

● Motor type

Y	AC servo motor
---	----------------

● Cable description

M	Motor cable
B	Motor cable for lock option
E	Encoder cable (With battery case)

● Cable type

S	Standard cable
R	Robotic cable

● Cable length (L) [m]

3	3
5	5
A	10
C	20

● Motor capacity

5	100 W
7	200/400 W

* For encoder cable, the suffix "□" (Motor capacity) is not necessary.

● Direction of connector

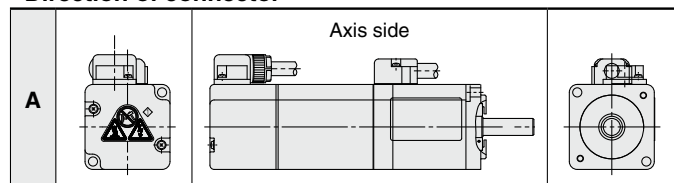

* The cable entry direction is axis side only.

Weight

Product no.	Length [m]	Weight [g]	Note
LE-CYM-S3A-5	3	250	100 W
LE-CYM-S5A-5	5	390	
LE-CYM-SAA-5	10	750	
LE-CYM-SCA-5	20	1500	
LE-CYM-S3A-7	3	250	200/ 400 W
LE-CYM-S5A-7	5	390	
LE-CYM-SAA-7	10	750	
LE-CYM-SCA-7	20	1500	
LE-CYM-R3A-5	3	220	100 W
LE-CYM-R5A-5	5	350	
LE-CYM-RAA-5	10	670	
LE-CYM-RCA-5	20	1300	
LE-CYM-R3A-7	3	220	200/ 400 W
LE-CYM-R5A-7	5	350	
LE-CYM-RAA-7	10	670	
LE-CYM-RCA-7	20	1300	

LE-CYM-□□A-□: Motor cable

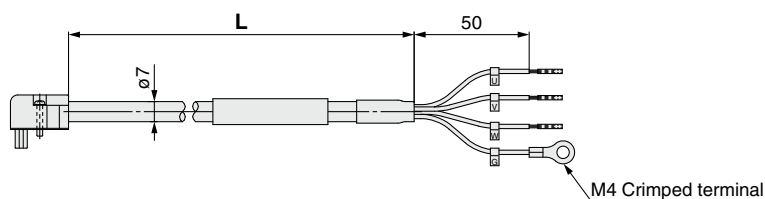

LE-CYB-□□A-□: Motor cable for lock option

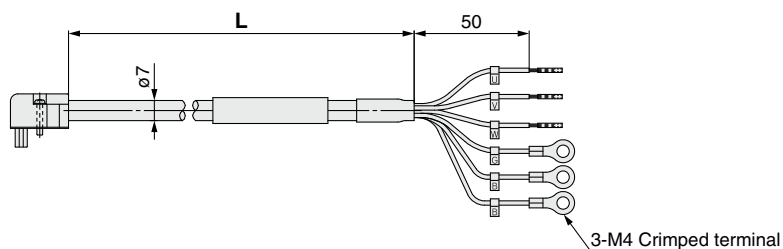

LE-CYE-□□A: Encoder cable

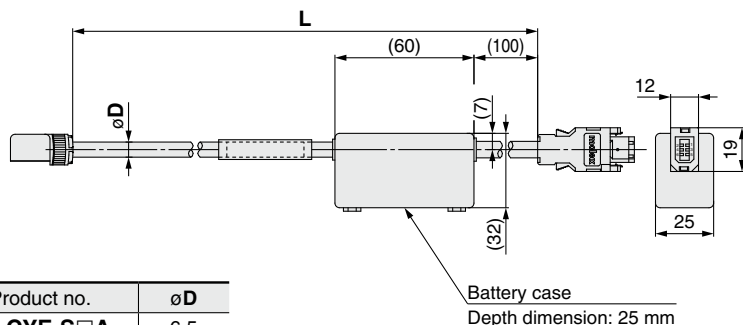

Product no.	øD
LE-CYE-S□A	6.5
LE-CYE-R□A	6.8

Weight

Product no.	Length [m]	Weight [g]	Note
LE-CYB-S3A-5	3	240	100 W
LE-CYB-S5A-5	5	390	
LE-CYB-SAA-5	10	750	
LE-CYB-SCA-5	20	1490	
LE-CYB-S3A-7	3	240	200/ 400 W
LE-CYB-S5A-7	5	390	
LE-CYB-SAA-7	10	750	
LE-CYB-SCA-7	20	1490	
LE-CYB-R3A-5	3	220	100 W
LE-CYB-R5A-5	5	350	
LE-CYB-RAA-5	10	670	
LE-CYB-RCA-5	20	1300	
LE-CYB-R3A-7	3	220	200/ 400 W
LE-CYB-R5A-7	5	350	
LE-CYB-RAA-7	10	670	
LE-CYB-RCA-7	20	1300	

Weight

Product no.	Length [m]	Weight [g]
LE-CYE-S3A	3	230
LE-CYE-S5A	5	360
LE-CYE-SAA	10	680
LE-CYE-SCA	20	1250
LE-CYE-R3A	3	220
LE-CYE-R5A	5	330
LE-CYE-RAA	10	660
LE-CYE-RCA	20	1240

* LE-CYM-S□A-□ is JZSP-CSM0□-□□-E manufactured by YASKAWA CONTROLS CO., LTD.
 LE-CYB-S□A-□ is JZSP-CSM1□-□□-E manufactured by YASKAWA CONTROLS CO., LTD.
 LE-CYE-S□A is JZSP-CSP05-□□-E manufactured by YASKAWA CONTROLS CO., LTD.

LE-CYM-R□A-□ is JZSP-CSM2□-□□-E manufactured by YASKAWA CONTROLS CO., LTD.
 LE-CYB-R□A-□ is JZSP-CSM3□-□□-E manufactured by YASKAWA CONTROLS CO., LTD.
 LE-CYE-R□A is JZSP-CSP25-□□-E manufactured by YASKAWA CONTROLS CO., LTD.

Options

I/O connector (Without cable, Connector only)

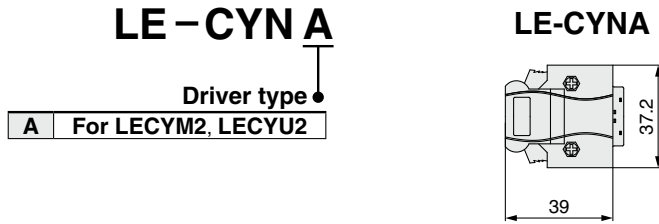

Weight

Product no.	Weight [g]
LE-CYNA	25

* LE-CYNA: 10126-3000PE (connector)/10326-52F0-008 (shell kit) manufactured by 3M Japan Limited or equivalent
 * Conductor size: AWG24 to 30

I/O cable

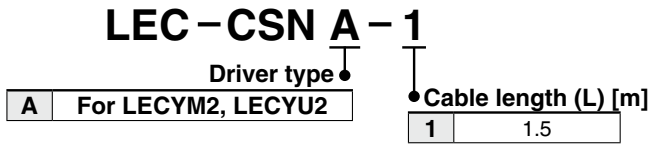

Weight

Product no.	Weight [g]
LEC-CSNA-1	303

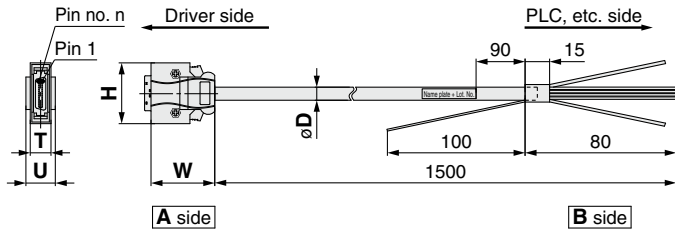

* LEC-CSNA-1: 10126-3000PE (connector)/10326-52F0-008 (shell kit) manufactured by 3M Japan Limited or equivalent
 * Conductor size: AWG24

Wiring

LEC-CSNA-1: Pin nos. 1 to 26

Connector pin no.	Pair no. of wire	Insulation color	Dot mark	Dot color	Connector pin no.	Pair no. of wire	Insulation color	Dot mark	Dot color	Connector pin no.	Pair no. of wire	Insulation color	Dot mark	Dot color	
A side	1	Orange	■	Red	A side	11	Orange	■ ■	Red	A side	21	Orange	■ ■ ■ ■	Red	
	2		■	Black		12		■ ■	Black		22		■ ■ ■ ■	Black	
	3	Light gray	■	Red		13	Light gray	■ ■	Red		23	Light gray	■ ■ ■ ■	Red	
	4		■	Black		14		■ ■	Black		24		■ ■ ■ ■	Black	
	5	White	■	Red		15	White	■ ■	Red		25	White	■ ■ ■ ■	Red	
	6		■	Black		16		■ ■	Black		26		■ ■ ■ ■	Black	
	7	Yellow	■	Red		17	Yellow	■ ■	Red						
	8		■	Black		18		■ ■	Black						
	9	Pink	■	Red		19	Pink	■ ■	Red						
	10		■	Black		20		■ ■	Black						

Cable O.D.

Product no.	øD
LEC-CSNA-1	11.1

Dimensions/Pin No.

Product no.	W	H	T	U	Pin no. n
LEC-CSNA-1	39	37.2	12.7	14	14

LECY^M_U Series

Options

MECHATROLINK cable type

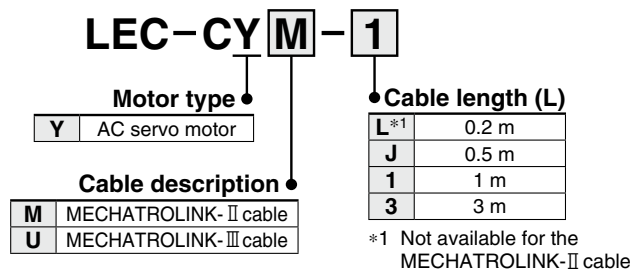

* LEC-CYM-□ is JEPMC-W6002-□□-E manufactured by YASKAWA CONTROLS CO., LTD.

* LEC-CYU-□ is JEPMC-W6012-□□-E manufactured by YASKAWA CONTROLS CO., LTD.

MECHATROLINK-II cable

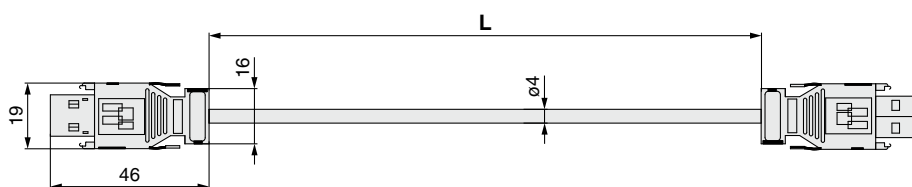

Weight

Product no.	Length [m]	Weight [g]
LEC-CYM-J	0.5	50
LEC-CYM-1	1	80
LEC-CYM-3	3	200

MECHATROLINK-III cable

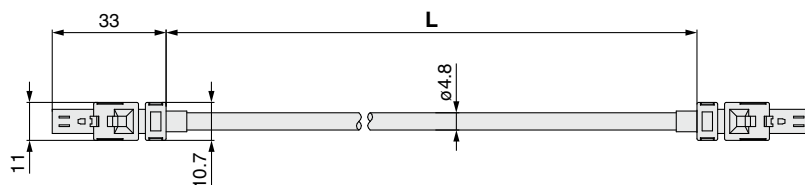

Weight

Product no.	Length [m]	Weight [g]
LEC-CYU-L	0.2	21
LEC-CYU-J	0.5	41
LEC-CYU-1	1	75
LEC-CYU-3	3	205

Terminating connector for MECHATROLINK-II

LEC-CYRM

* LEC-CYRM is JEPMC-W6022-E manufactured by YASKAWA CONTROLS CO., LTD.

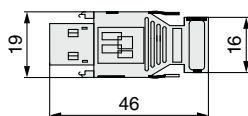

Weight: 10 g

Options



LECYM2 LECYU2
Drivers



USB cable

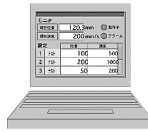

PC

Setup software (SigmaWin+™) (LECYM/LECYU common)

- * Please download the SigmaWin+™ via our website.
- SigmaWin+™ is a registered trademark or trademark of YASKAWA Electric Corporation.

Adjustment, waveform display, parameter read/write, and test operation can be performed upon a PC.

Compatible PC

When using setup software (SigmaWin+™), use an IBM PC/AT compatible PC that meets the following operating conditions.

Hardware Requirements

Equipment		Setup software (SigmaWin+™)
PC *1, 2, 3, 4	OS	Windows® XP*5, Windows Vista®, Windows® 7 (32-bit/64-bit)
	Available HD space	350 MB or more (When the software is installed, 400 MB or more is recommended.)
	Communication interface	Use USB port.
Display		XVGA monitor (1024 x 768 or more, "The small font is used.") 256 color or more (65536 color or more is recommended.) Connectable with the PC above
Keyboard		Connectable with the PC above
Mouse		Connectable with the PC above
Printer		Connectable with the PC above
USB cable		LEC-JZ-CVUSB*6
Other		Adobe Reader Ver. 5.0 or higher (* Except Ver. 6.0)

- *1 Windows, Windows Vista®, Windows® 7 are registered trademarks of Microsoft Corporation in the United States and/or other countries.
- *2 On some PCs, this software may not run properly.
- *3 Not compatible with 64-bit Windows® XP and 64-bit Windows Vista®
- *4 For Windows® XP, please use it by the administrator authority (When installing and using it.)
- *5 In PC that uses the program to correct the problem of HotfixQ328310, it is likely to fail in the installation. In that case, please use the program to correct the problem of HotfixQ329623.
- *6 Order USB cable separately.

Battery (LECYM/LECYU common)

LEC-JZ-CVBAT

- * JZSP-BA01 manufactured by YASKAWA CONTROLS CO., LTD.

Battery for replacement

Absolute position data is maintained by installing the battery to the battery case of the encoder cable.

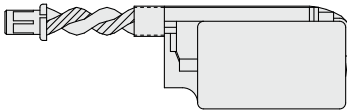

Weight: 10 g

USB cable (2.5 m)

LEC-JZ-CVUSB

- * JZSP-CVS06-02-E manufactured by YASKAWA CONTROLS CO., LTD.

Cable for connecting PC and driver when using the setup software (SigmaWin+™)

Do not use any cable other than this cable.

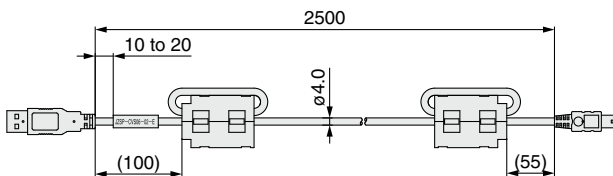

Weight: 150 g

Cable for safety function device (3 m)

LEC-JZ-CVSAF

- * JZSP-CVH03-03-E manufactured by YASKAWA CONTROLS CO., LTD.

Cable for connecting the driver and device when using the safety function

Do not use any cable other than this cable.

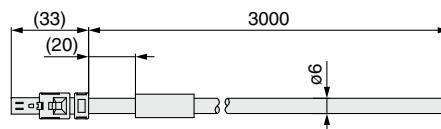

Weight: 160 g



LECS□/LECS□-T/LECY□ Series

Specific Product Precautions 1

Be sure to read this before handling the products. For safety instructions and electric actuator precautions, refer to the “Handling Precautions for SMC Products” and the “Operation Manual” on the SMC website: <https://www.smcworld.com>

Design / Selection

Warning

- 1. Be sure to apply the specified voltage.**
Otherwise, malfunction or breakage may occur. If the applied voltage is lower than the specified voltage, it is possible that the load will not be able to be moved due to an internal voltage drop of the driver. Please check the operating voltage before use.
- 2. Do not operate the product beyond the specifications.**
Otherwise, a fire, malfunction, or actuator damage may result. Please check the specifications before use.
- 3. Install an emergency stop circuit.**
Please install an emergency stop outside of the enclosure so that the system operation can be stopped immediately and the power supply can be intercepted.
- 4. In order to prevent any damage caused by the breakdown or malfunction of the driver and its peripheral devices, a backup system should be established in advance by giving a multiple-layered structure or a fail-safe design to the equipment, etc.**
- 5. If a danger of human injury is expected due to abnormal heat generation, smoking, ignition, etc., of the driver and its peripheral devices, cut off the power supply of the product and the system immediately.**
- 6. The parameters of the driver are set to initial values. Please change the parameters according to the specifications of the customer's equipment before use. Refer to the operation manual for parameter details.**

Handling

Warning

- 1. Do not touch the inside of the driver and its peripheral devices.**
Doing so may cause an electric shock or damage to the driver.
- 2. Do not perform the operation or setting of the product with wet hands.**
Doing so may cause an electric shock.
- 3. Products with damage or those missing any components should not be used.**
An electric shock, fire, or injury may result.
- 4. Use only the specified combination between the electric actuator and driver.**
Failure to do so may cause damage to the actuator or the driver.
- 5. Be careful not to be hit by workpieces while the actuator is moving.**
It may cause an injury.
- 6. Do not connect the power supply or power on the product before confirming the area to which the workpiece moves is safe.**
The movement of the workpiece may cause an accident.
- 7. Do not touch the product when it is energized and for some time after power has been disconnected, as it is very hot.**
Doing so may lead to a burn due to the high temperature.
- 8. Before installation, wiring, and maintenance, the voltage should be checked with a tester 5 minutes after the power supply has been turned off.**
Otherwise, an electric shock, fire, or injury may result.

Handling

Warning

- 9. Static electricity may cause malfunction or break the driver. Do not touch the driver while power is supplied.**
When touching the driver for maintenance, take sufficient measures to eliminate static electricity.
- 10. Do not use the product in an area where dust, powder dust, water, chemicals, or oil is in the air.**
It will cause failure or malfunction.
- 11. Do not use the product in an area where a magnetic field is generated.**
It will cause failure or malfunction.
- 12. Do not install the product in an environment containing flammable gas, explosive gas, or corrosive gas.**
It could lead to fire, explosion, or corrosion.
- 13. Radiant heat from strong heat sources, such as a furnace, direct sunlight, etc., should not be applied to the product.**
It will cause failure of the driver or its peripheral devices.
- 14. Do not use the product in an environment subject to a temperature cycle.**
It will cause failure of the driver or its peripheral devices.
- 15. Do not use the product in a place where surges are generated.**
When there are units that generate a large amount of surge around the product (e.g. solenoid type lifters, high-frequency induction furnaces, motors, etc.), this may cause deterioration or damage to the product's internal circuit. Avoid sources of surge generation and crossed lines.
- 16. Do not install the product in an environment under the effect of vibrations and impacts.**
It will cause failure or malfunction.
- 17. When a surge-generating load, such as a relay or solenoid valve, is driven directly, use a product that incorporates a surge absorption element.**

Installation

Warning

- 1. Install the driver and its peripheral devices on a fire-proof material.**
Direct installation on or near a flammable material may cause a fire.
- 2. Do not install the product in a place subject to vibrations and impacts.**
It will cause failure or malfunction.
- 3. The driver should be mounted on a vertical wall in a vertical direction. Also, be sure not to cover the driver's suction/exhaust ports.**
- 4. Install the driver and its peripheral devices on a flat surface.**
If the mounting surface is distorted or uneven, an unacceptable force may be added to the housing, etc., causing problems.



LECS□/LECS□-T/LECY□ Series Specific Product Precautions 2

Be sure to read this before handling the products. For safety instructions and electric actuator precautions, refer to the “Handling Precautions for SMC Products” and the “Operation Manual” on the SMC website: <https://www.smcworld.com>

Power Supply

⚠ Caution

1. Use a power supply that has low noise between lines and between the power and ground.
In cases where noise is high, an isolation transformer should be used.
2. To prevent lightning surges, appropriate measures should be taken. Ground the surge absorber for lightning separately from the grounding of the driver and its peripheral devices.

Wiring

⚠ Warning

1. The driver will be damaged if a commercial power supply (100/200 V) is added to the driver's servo motor power (U, V, and W). Be sure to check wiring for mistakes when the power supply is turned on.
2. Connect the ends of the U, V, and W wires of the motor cable correctly to the phases (U, V, and W) of the servo motor power. If these wires do not match up, the servo motor cannot be controlled.

Grounding

⚠ Warning

1. For grounding the actuator, connect the copper wire of the actuator to the driver's protective earth (PE) terminal and connect the copper wire of the driver to the earth via the control panel's protective earth (PE) terminal. Do not connect them directly to the control panel's protective earth (PE) terminal.

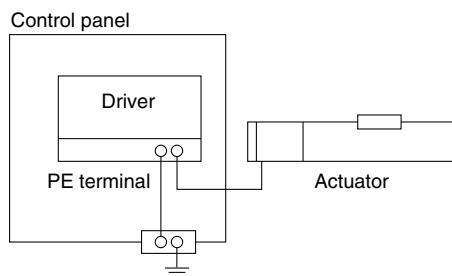

2. In the unlikely event that a malfunction is caused by the ground, please disconnect it.

Maintenance

⚠ Warning

1. Perform a maintenance and inspection periodically.
Confirm wiring and screws are not loose.
Loose screws or wires may cause unintentional malfunction.
2. Conduct an appropriate functional inspection after completing the maintenance and inspection.
At times where the equipment or machinery does not operate properly, conduct an emergency stop of the system. Otherwise, an unexpected malfunction may occur and it will become impossible to ensure safety. Conduct a test of the emergency stop in order to confirm the safety of the equipment.
3. Do not disassemble, modify, or repair the driver and its peripheral devices.
4. Do not put anything conductive or flammable inside the driver.
It may cause a fire.
5. Do not conduct an insulation resistance test or withstand voltage test on this product.
6. Ensure sufficient space for maintenance activities.
Design the system allowing the required space for maintenance and inspection.

 **Safety Instructions** Be sure to read the "Handling Precautions for SMC Products" (M-E03-3) and "Operation Manual" before use.