

**Built-in Intermediate Supports**

**AC Servo Motor**

**Motorless**

# Electric Actuator: High Rigidity Slider Type Ball Screw Drive



[Excludes the motorless type]

- A maximum speed of 1,800 mm/s\*<sup>1</sup> has been achieved throughout the entire stroke!

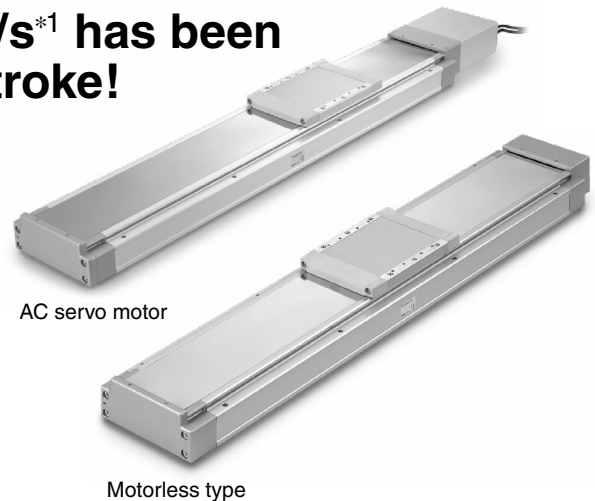
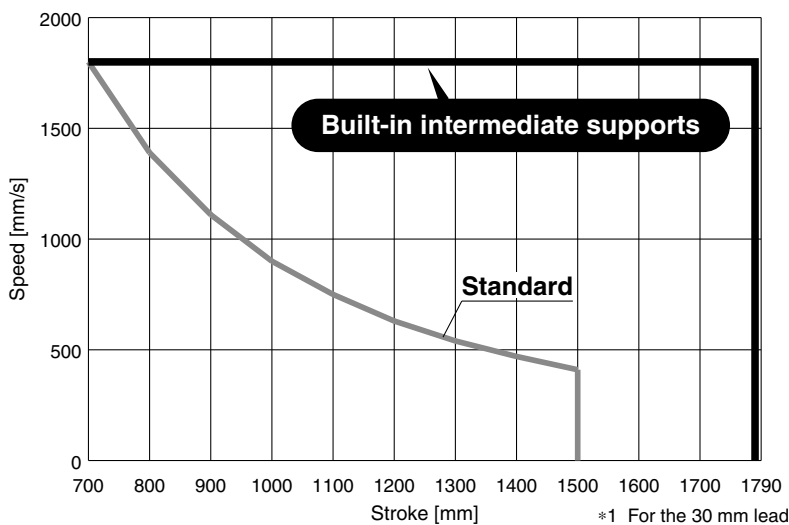

The use of intermediate supports results in reduced deflection of the ball screw when a long stroke is used.

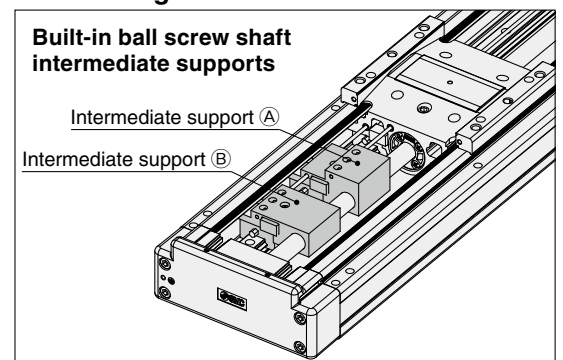

- Max. stroke: 1,790 mm
- Horizontal work load: 85 kg (For the 10 mm lead)
- Positioning repeatability:  $\pm 0.01$  mm (High-precision type)

**AC Servo Motor**

**For absolute encoders**

- Pulse input type  
LECSB Series
- CC-Link direct input type  
LECSC Series
- SSCNET III type  
LECSS Series
- SSCNET III/H type  
LECSS-T Series
- MECHATROLINK type  
LECY□ Series



**For incremental encoders**

- Pulse input type/  
Positioning type  
LECSA Series



**Motorless** Manufacturers of compatible motors: 13 companies

- Mitsubishi Electric Corporation ● YASKAWA Electric Corporation ● SANYO DENKI CO., LTD. ● OMRON Corporation ● Panasonic Corporation
- FANUC CORPORATION ● NIDEC SANKYO CORPORATION ● KEYENCE CORPORATION ● FUJI ELECTRIC CO., LTD.
- Rockwell Automation, Inc. (Allen-Bradley) ● Beckhoff Automation GmbH ● Siemens AG ● Delta Electronics, Inc.

## LEJS63□-□M Series



# Electric Actuator: High Rigidity Slider Type Ball Screw Drive

## LEJS63□-□M Series

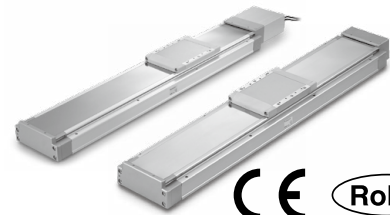

### How to Order

#### AC Servo Motor

LEJS **H** 63 **S3** **A** - **790** □ **M** - □ □ □ □

① ② ③ ④ ⑤ ⑥ ⑦ ⑧ ⑨ ⑩ ⑪

#### ① Accuracy

Nil	Basic type
H	High-precision type

#### ② Size

63

#### ③ Motor type

Symbol	Type	Output [W]	Actuator size	Compatible driver
S3	AC servo motor (Incremental encoder)	200	63	LECSA□-S3
S7	AC servo motor (Absolute encoder)	200	63	LECSB□-S7 LECS□-S7 LECSS□-S7
T7	AC servo motor (Absolute encoder)	200	63	LECSS2-T7
V7	AC servo motor (Absolute encoder)	200	63	LECYM2-V7 LECYU2-V7

#### ④ Lead [mm]

H	30
A	20
B	10

#### ⑤ Stroke [mm]\*1

● Standard ○ Produced upon receipt of order

790	890	990	1190	1490	1790
●	●	○	○	○	○

\*1 Please consult with SMC for non-standard strokes as they are produced as special orders.

#### ⑥ Motor option

Nil	None
B	With lock

#### ⑦ Built-in intermediate supports

M	Built-in intermediate supports
---	--------------------------------

#### ⑧ Cable type\*2 \*3

Nil	Without cable
S	Standard cable
R	Robotic cable (Flexible cable)

\*2 When a driver type is selected, a cable is included. Select the cable type and cable length.

Example)

S2S2: Standard cable (2 m) + Driver (LECSS2)

S2: Standard cable (2 m)

Nil: Without cable and driver

\*3 The motor and encoder cables are included. (The lock cable is included when the motor with lock option is selected.)

#### ⑨ Cable length\*2 \*4

Nil	Without cable	Motor type	
		S□/T□	V□
2	2	●	—
3	3	—	●
5	5	●	●
A	10	●	●
C	20	—	●

\*4 The length of the motor, encoder, and lock cables are the same.

#### ⑩ Driver type\*2

Symbol	Compatible driver	Power supply voltage [V]
Nil	Without driver	—
A1	LECSA1-S□	100 to 120
A2	LECSA2-S□	200 to 230
B1	LECSB1-S□	100 to 120
B2	LECSB2-S□	200 to 230
C1	LECS□-S□	100 to 120
C2	LECS□-S□	200 to 230
S1	LECSS1-S□	100 to 120
	LECSS2-S□	200 to 230
S2	LECSS2-T□	200 to 240
	LECSS2-S□	200 to 230
M2	LECYM2-V□	200 to 230
U2	LECYU2-V□	200 to 230

#### ⑪ I/O connector\*5

Nil	Without cable
H	Without cable (Connector only)
1	1.5 [m]

\*5 When "Without driver" is selected, only "Without cable" can be selected.

## How to Order

Motorless

**LEJS H 63 NZ A - 790 M**

① ② ③ ④ ⑤ ⑥

### ① Accuracy

Nil	Basic type
H	High-precision type

### ② Size

63

### ③ Motor type

NZ	Mounting type Z
NY	Mounting type Y
NX	Mounting type X
NW	Mounting type W
NV	Mounting type V
NU	Mounting type U
NT	Mounting type T

### ④ Lead [mm]

H	30
A	20
B	10

### ⑤ Stroke [mm]\*1

● Standard ○ Produced upon receipt of order

790	890	990	1190	1490	1790
●	●	○	○	○	○

\*1 Please consult with SMC for non-standard strokes as they are produced as special orders.

### ⑥ Built-in intermediate supports

M	Built-in intermediate supports
---	--------------------------------

## Specifications

		Lead [mm]			
Work load [kg]	Horizontal		30	20	10
	Vertical		30	45	85
Speed [mm/s]	Stroke range	790	1800	1200	600
		890			
		990			
		1190			
		1490			
		1790			

Other specifications that are not listed are the same as those of the standard product. For details, refer to the **Web Catalog**.

## Construction

Top view of actuator (Shown with the dust seal band removed)

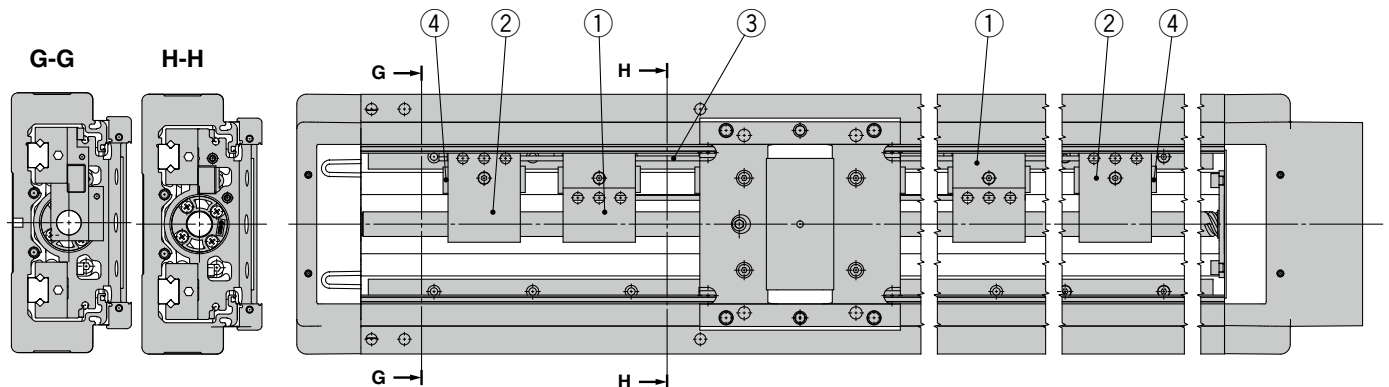

### Component Parts

No.	Description	Material
1	Support A	Synthetic resin
2	Support B	Synthetic resin
3	Connection pipe	Stainless steel
4	Bumper	Low-elasticity rubber

# LEJS63□-□M Series

## Dimensions: Ball Screw Drive

### AC servo motor

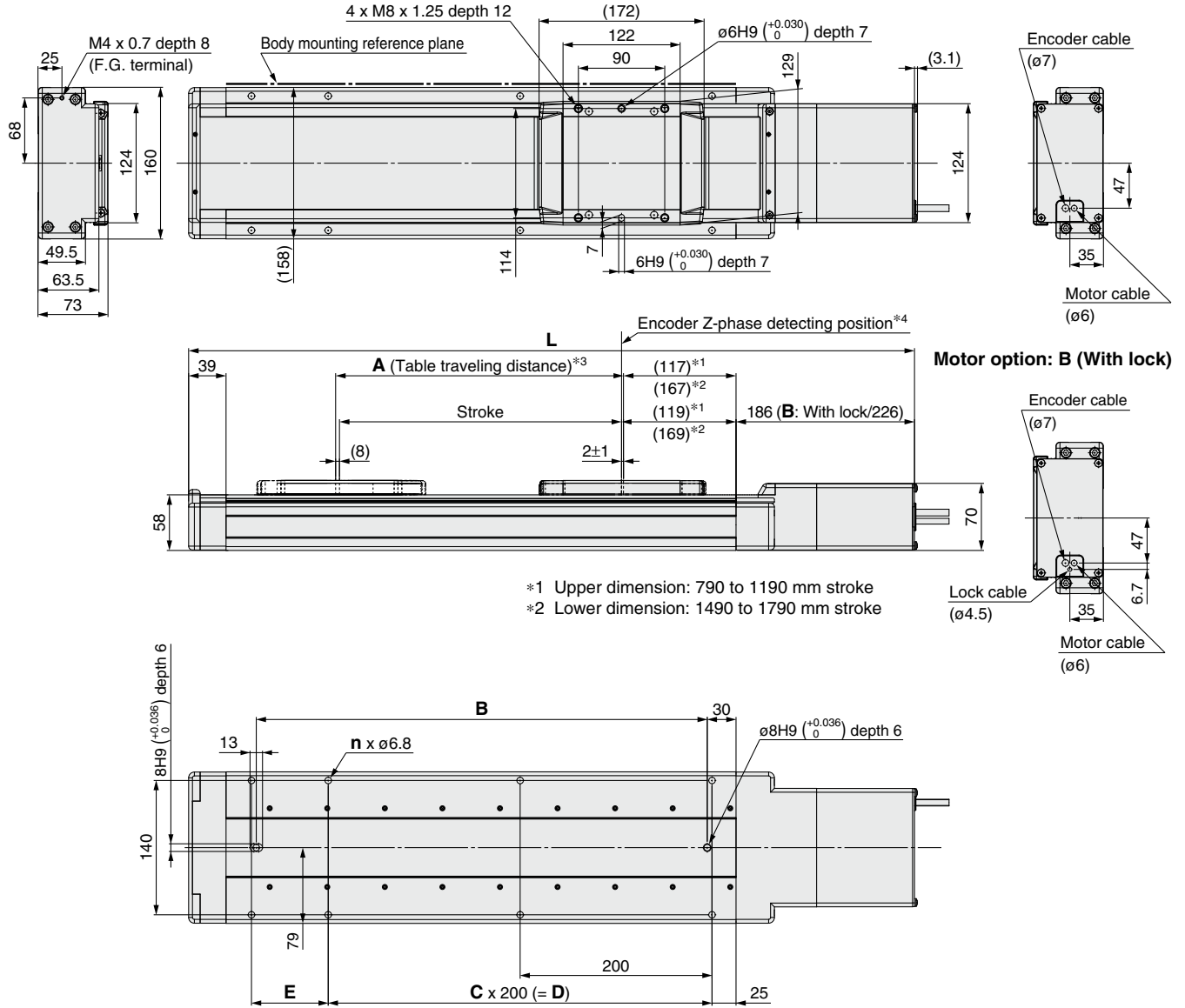

\*3 This is the distance within which the table can move when it returns to origin. Make sure workpieces mounted on the table do not interfere with the workpieces and facilities around the table.

\*4 The Z-phase first detecting position from the stroke end of the motor side

\* The auto switch magnet is located in the table center.

## Dimensions and Weight

Model	L		A	B	n	C	D	E	Product weight*1 [kg]
	Without lock	With lock							
LEJS□63□□-790□M-□□□□	1256.5	1296.5	800	970	12	4	800	180	19.4
LEJS□63□□-890□M-□□□□	1356.5	1396.5	900	1070	14	5	1000	80	20.7
LEJS□63□□-990□M-□□□□	1456.5	1496.5	1000	1170	14	5	1000	180	21.9
LEJS□63□□-1190□M-□□□□	1656.5	1696.5	1200	1370	16	6	1200	180	24.4
LEJS□63□□-1490□M-□□□□	2056.5	2096.5	1500	1770	20	8	1600	180	29.9
LEJS□63□□-1790□M-□□□□	2356.5	2396.5	1800	2070	24	10	2000	80	33.7

\*1 When using a lock, add 0.4 (incremental encoder) or 0.7 (absolute encoder).

Refer to the "Motor Mounting" on page 5 for details about motor mounting and included parts.

**Dimensions: Ball Screw Drive**

**Motorless**

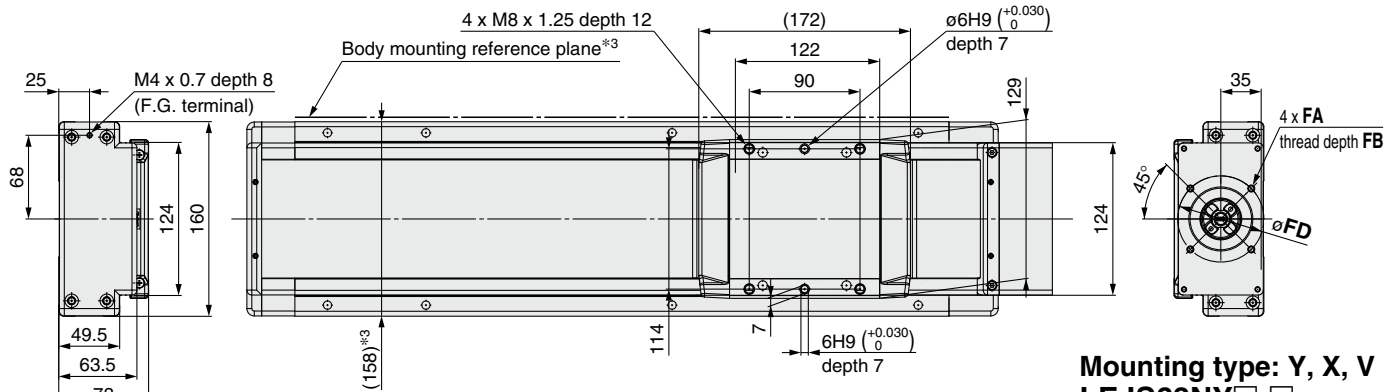

Mounting type: Y, X, V  
**LEJS63NY□-□**  
**LEJS63NX□-□**  
**LEJS63NV□-□**

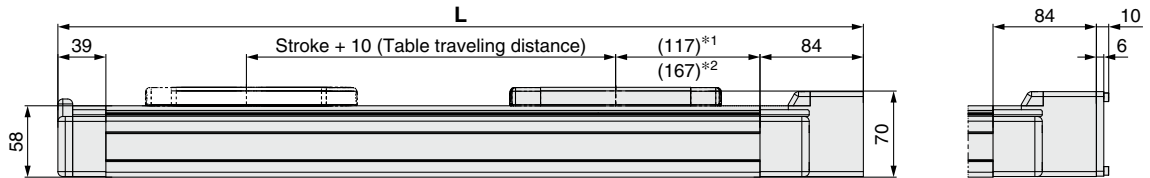

\*1 Upper dimension: 790 to 1190 mm stroke  
 \*2 Lower dimension: 1490 to 1790 mm stroke

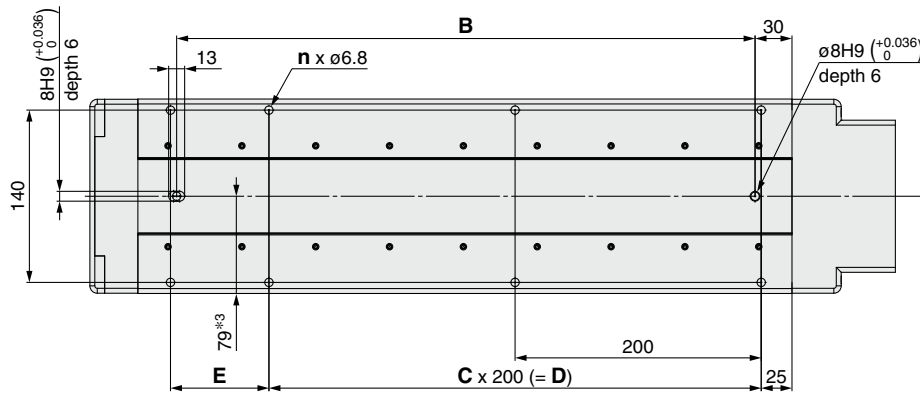

\*3 When mounting the actuator using the body mounting reference plane, use a pin. Set the height of the pin to be 5 mm or more because of round chamfering. (Recommended height 6 mm)

**Dimensions and Weight**

Model	L	B	n	C	D	E	Product weight [kg]
LEJS□63N□□-790M	1154.5	970	12	4	800	180	18.4
LEJS□63N□□-890M	1254.5	1070	14	5	1000	80	19.7
LEJS□63N□□-990M	1354.5	1170	14	5	1000	180	20.9
LEJS□63N□□-1190M	1554.5	1370	16	6	1200	180	23.4
LEJS□63N□□-1490M	1954.5	1770	20	8	1600	180	28.9
LEJS□63N□□-1790M	2254.5	2070	24	10	2000	80	32.7

**Motor Mounting Dimensions**

Motor type	FA	FB	FD
NZ/Mounting type Z	M5 x 0.8	7	70
NY/Mounting type Y	M4 x 0.7	6	70
NX/Mounting type X	M5 x 0.8	6	63
NW/Mounting type W	M5 x 0.8	7	70
NV/Mounting type V	M4 x 0.7	6	63
NU/Mounting type U	M5 x 0.8	7	70
NT/Mounting type T	M5 x 0.8	7	70

# LEJS63□-□M Series

- When mounting a hub, remove all oil content, dust, and dirt adhered to the shaft and the inside of the hub.
- This product does not include the motor and motor mounting screws. (Provided by user)  
Prepare a motor with a round shaft end.
- Take measures to prevent the loosening of the motor mounting screws.

## Motor Mounting

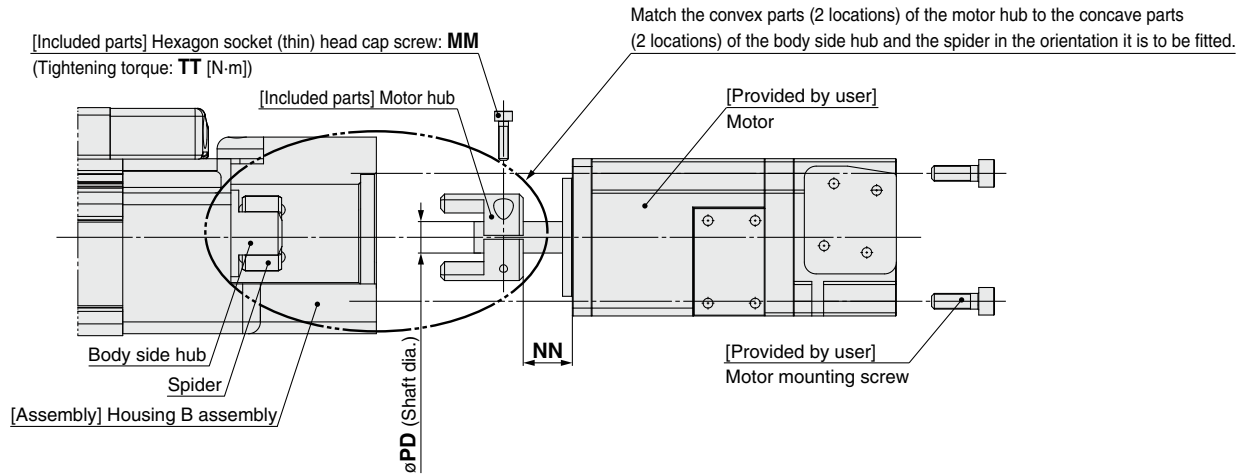

### Mounting procedure

- 1) Secure the motor hub to the motor (provided by user) with the MM hexagon socket head cap screw.
- 2) Check the motor hub position, and then insert it.
- 3) Secure the motor to the housing B assembly with the motor mounting screws (provided by user).

### Dimensions

Size	Motor type	MM	TT	NN	PD
63	NZ/Mounting type Z	M3 x 12	1.5	18	14
	NY/Mounting type Y	M4 x 12	2.7	18	11
	NX/Mounting type X	M4 x 12	2.7	8	9
	NW/Mounting type W	M4 x 12	2.7	12	9
	NV/Mounting type V	M4 x 12	2.7	8	9
	NU/Mounting type U	M4 x 12	2.7	12	11
	NT/Mounting type T	M3 x 12	1.5	18	12

### Included Parts List

#### Size: 63

Description	Qty.	Note
Motor hub	1	—
Hexagon socket head cap screw (to secure the hub)	1	M3 x 12: Motor type NZ, NT
Hexagon socket thin head cap screw (to secure the hub)		M4 x 12: Motor type NY, NX, NW, NV, NU

### ⚠ Caution

1. During operation, the intermediate support mechanism emits a collision noise due to the structure.
2. Compared to the standard product, the entire length of the product will be longer for each stroke. For details, refer to the dimensions.
3. The stopper type origin position return method cannot be used as the return to origin method (due to the bumper as shown in Construction ④).

 **Safety Instructions** Be sure to read the "Handling Precautions for SMC Products" (M-E03-3) and "Operation Manual" before use.